

## W55412A



### VOICE PROM (256K OTP)

#### GENERAL DESCRIPTION

The W55412A is a 256K × 1 bit one-time programmable (OTP) ROM. The W55412A is designed for easy cascading with Winbond speech ICs to emulate sounds and functions. The W55412A data ROM allows synthesis of messages of up to 12 seconds in duration (not including repetition or silence).

#### FEATURES

- Provides RDP, WRP, and DATA pins to cascade with Winbond speech ICs
- Data and address are processed in serial form
- Suitable for low pin count applications (8-pin DIP)
- Low power consumption:
  - Operating: 3 mA (max.)
  - Standby: 1μA (max.)
- Programming voltage (VPP): 12 to 12.5V
- Operating voltage range: 3 to 5V
- Organized as 256K × 1 bit
- Data access time: 500 nS (max.)

#### PIN CONFIGURATION

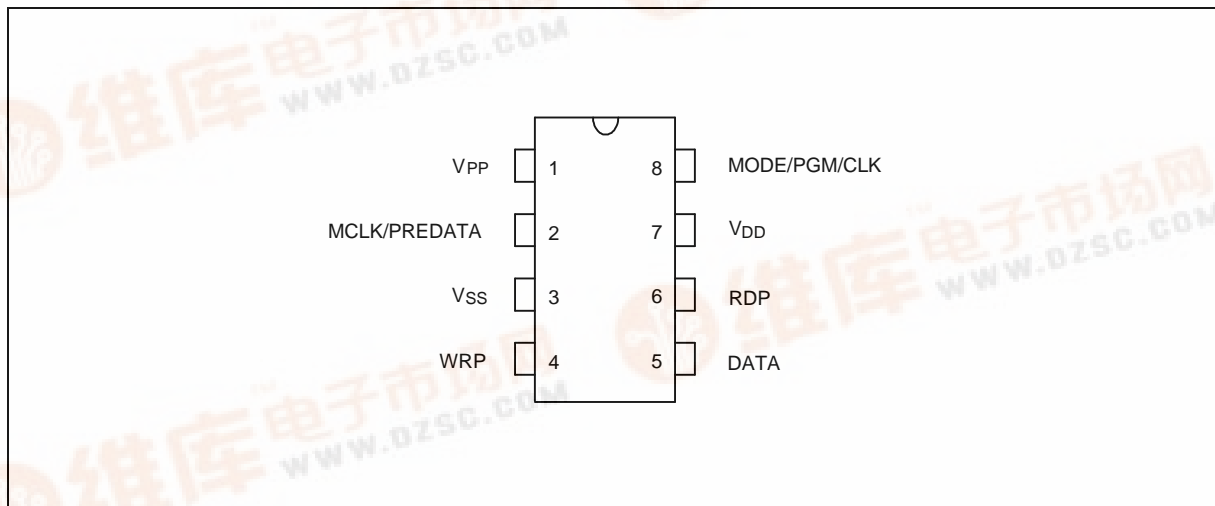



## PIN DESCRIPTION

NO.	PIN NAME	I/O	DESCRIPTION	
			Read	Program/Erase/Repair
1	VPP	I	NC	Logic input
2	MCLK/PREDATA	I/O	NC	Logic input
3	VSS	I	Negative power supply	Negative power supply
4	WRP	I/O	Write clock pulse line	No use
5	DATA	I/O	Bidirectional data line	No use
6	RDP	I	Read clock pulse line	No use
7	VDD	I	Positive voltage supply	Positive voltage supply
8	MODE/PGM/CLK	I	NC	Logic input

## BLOCK DIAGRAM

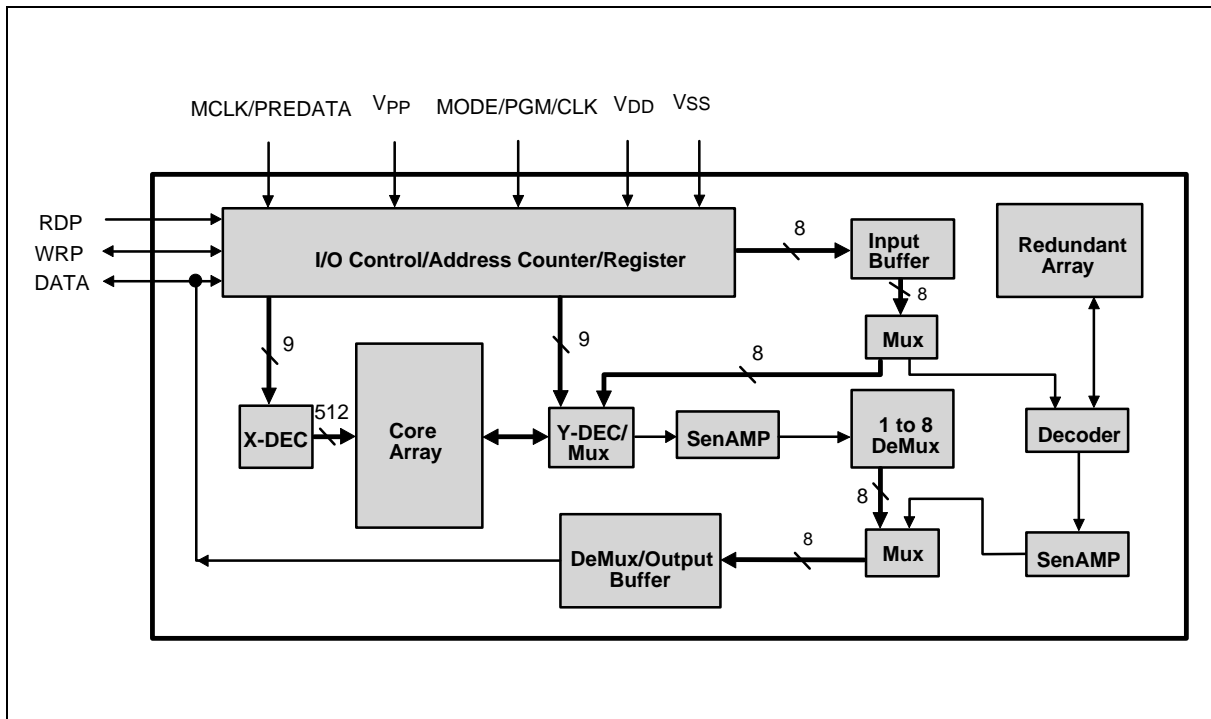

## FUNCTIONAL DESCRIPTION

Voice data are written to the W55412A using the Winbond writer and the Winbond Coding System. The voice data must be converted to \*.obj form before being written to the W55412A.

# W55412A



The W55412A's read function allows data stored on the chip to be accessed by an OTP demo board cascaded with a Winbond *PowerSpeech* body.

The DATA pin is a bidirectional pin used for address input and data output. The MODE/PGM/CLK, VPP, and MCLK/PREDATA pins are used to program or erase the chip, not used in the normal read mode.

## ABSOLUTE MAXIMUM RATINGS

SYMBOL	RATING	UNIT	NOTES
VDD	-0.5 to +7.0	V	1, 2
VIN	VSS -0.5 to VDD +0.5	V	3, 2
VOUT	VSS -0.5 to VDD +0.5	V	3, 2
TOPR	0 to 70	°C	4
PD	200	mW	5

Notes:

1. Exposure to conditions beyond those listed under Absolute Maximum Ratings may adversely affect the life and reliability of the device.
2. All voltages are referenced to Vss.
3. VIN and VOUT refer to pins WRP, RDP, DATA, and MCLK/PREDATA.
4. TOPR: Operating temperature for commercial market.
5. PD: Maximum power dissipation without output load.

## DC CHARACTERISTICS

(VDD = 4.5 V, VSS = 0 V, TA = 0 to 70° C)

PARAMETER		SYMBOL	MIN.	TYP.	MAX.	CONDITIONS VDD = 4.5V
Power Supply Voltage		VDD	2.4V	4.5V	5.0V	-
Standby Current		ISB	-	-	1 $\mu$ A	No Load
Operating Current		IDD	-	-	3 mA	-
Input Current (WRP, RDP)		II	-	-	0.2 $\mu$ A	-
Output Current (DATA)	Drive	IO	-250 $\mu$ A	-	-	VDATA = 4.2 V
	Sink		250 $\mu$ A	-	-	VDATA = 0.3 V



**AC CHARACTERISTICS**

(V<sub>DD</sub> = 4.5 V, T<sub>A</sub> = 0 to 70° C)

PARAMETER	SYMBOL	MIN.	TYP.	MAX.	UNIT
Data Setup Time	T <sub>DS</sub>	-	-	1	μS
Data Hold Time	T <sub>DH</sub>	0	-	-	μS
Output Enable to Data Valid	T <sub>OE</sub>	-	-	500	nS
Output Data Hold Time	T <sub>OH</sub>	100	-	-	nS
Write End to Read Setup Time	T <sub>WRS</sub>	2	-	-	μS

Note: T<sub>DS</sub>, T<sub>DH</sub>, T<sub>OE</sub>, T<sub>OH</sub>, and T<sub>WRS</sub> are shown below:

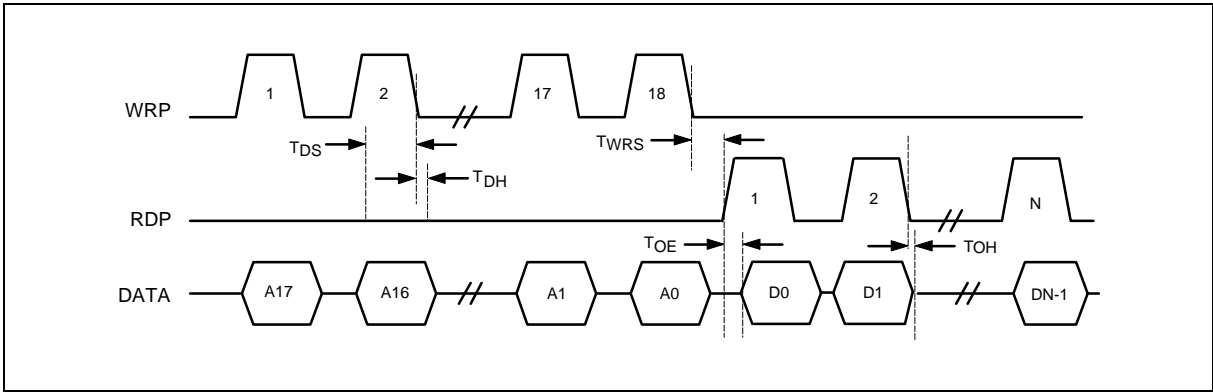

**TYPICAL APPLICATION CIRCUIT**

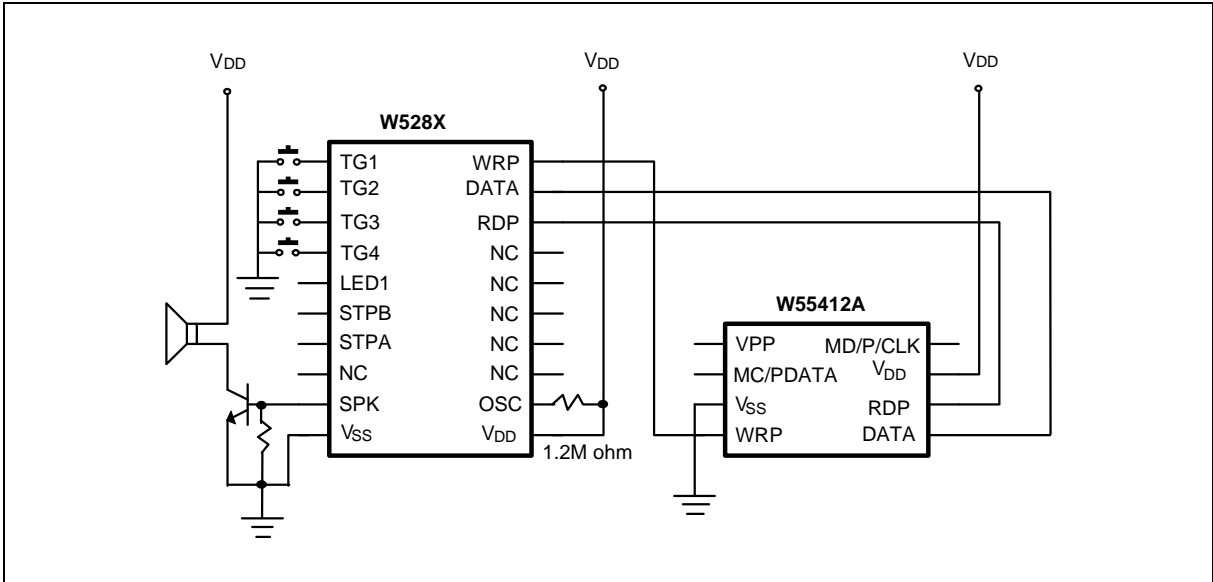

# W55412A



#### Headquarters

No. 4, Creation Rd. III,  
Science-Based Industrial Park,  
Hsinchu, Taiwan  
TEL: 886-3-5770066  
FAX: 886-3-5792697

<http://www.winbond.com.tw/>

Voice & Fax-on-demand: 886-2-7197006

#### Taipei Office

11F, No. 115, Sec. 3, Min-Sheng East Rd.,  
Taipei, Taiwan  
TEL: 886-2-7190505  
FAX: 886-2-7197502

#### Winbond Electronics (H.K.) Ltd.

Rm. 803, World Trade Square, Tower II,  
123 Hoi Bun Rd., Kwun Tong,  
Kowloon, Hong Kong  
TEL: 852-27516023  
FAX: 852-27552064

#### Winbond Electronics North America Corp.

Winbond Memory Lab.  
Winbond Microelectronics Corp.  
Winbond Systems Lab.

2730 Orchard Parkway, San Jose,  
CA 95134, U.S.A.  
TEL: 1-408-9436666  
FAX: 1-408-9436668

Note: All data and specifications are subject to change without notice.