2SC4196

Silicon NPN Epitaxial

HITACHI

Application

UHF Local oscillator

Outline

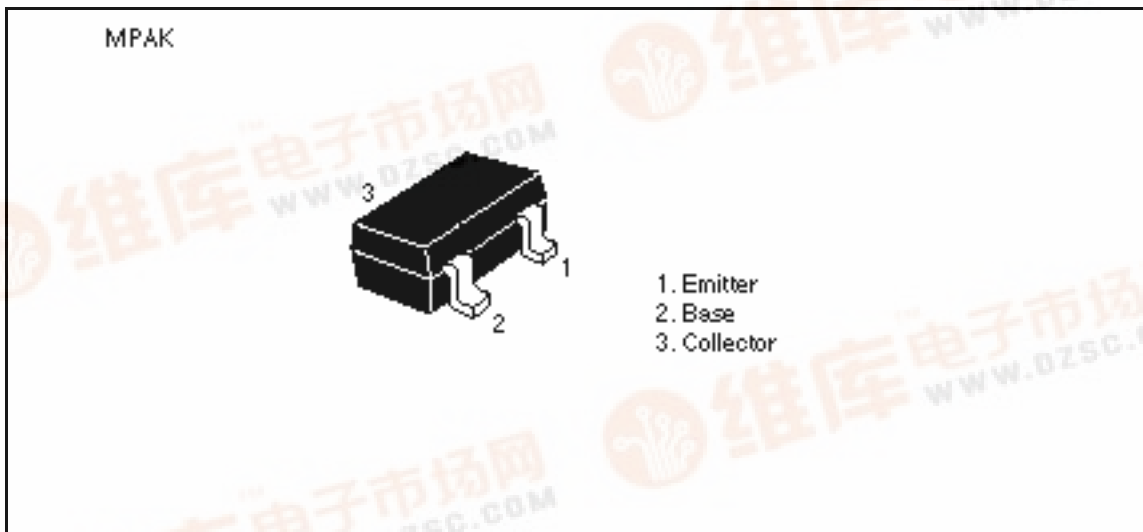

2SC4196

Absolute Maximum Ratings (Ta = 25°C)

Item	Symbol	Ratings	Unit
Collector to base voltage	V_{CBO}	25	V
Collector to emitter voltage	V_{CEO}	15	V
Emitter to base voltage	V_{EBO}	3	V
Collector current	I_C	50	mA
Collector power dissipation	P_C	150	mW
Junction temperature	T_j	150	°C
Storage temperature	T_{stg}	-55 to +150	°C

Electrical Characteristics (Ta = 25°C)

Item	Symbol	Min	Typ	Max	Unit	Test conditions
Collector to base breakdown voltage	$V_{(BR)CBO}$	25	—	—	V	$I_C = 10 \mu A, I_E = 0$
Collector cutoff current	I_{CBO}	—	—	0.3	μA	$V_{CB} = 15 V, I_E = 0$
	I_{CEO}	—	—	10	μA	$V_{CE} = 15 V, R_{BE} =$
Emitter cutoff current	I_{EBO}	—	—	1.0	μA	$V_{EB} = 3 V, I_C = 0$
Collector to emitter saturation voltage	$V_{CE(sat)}$	—	—	0.3	V	$I_C = 20 mA, I_B = 4 mA$
DC current transfer ratio	h_{FE}	50	—	180		$V_{CE} = 5 V, I_C = 5 mA$
Collector output capacitance	C_{ob}	—	0.7	1.0	pF	$V_{CB} = 10 V, I_E = 0, f = 1MHz$
Gain bandwidth product	f_T	1.8	2.4	—	GHz	$V_{CE} = 5 V, I_C = 20 mA$
Oscillating output voltage	V_{OSC}	—	200	—	mV	$V_{CC} = 5 V, I_C = 5 mA, f = 930 MHz$

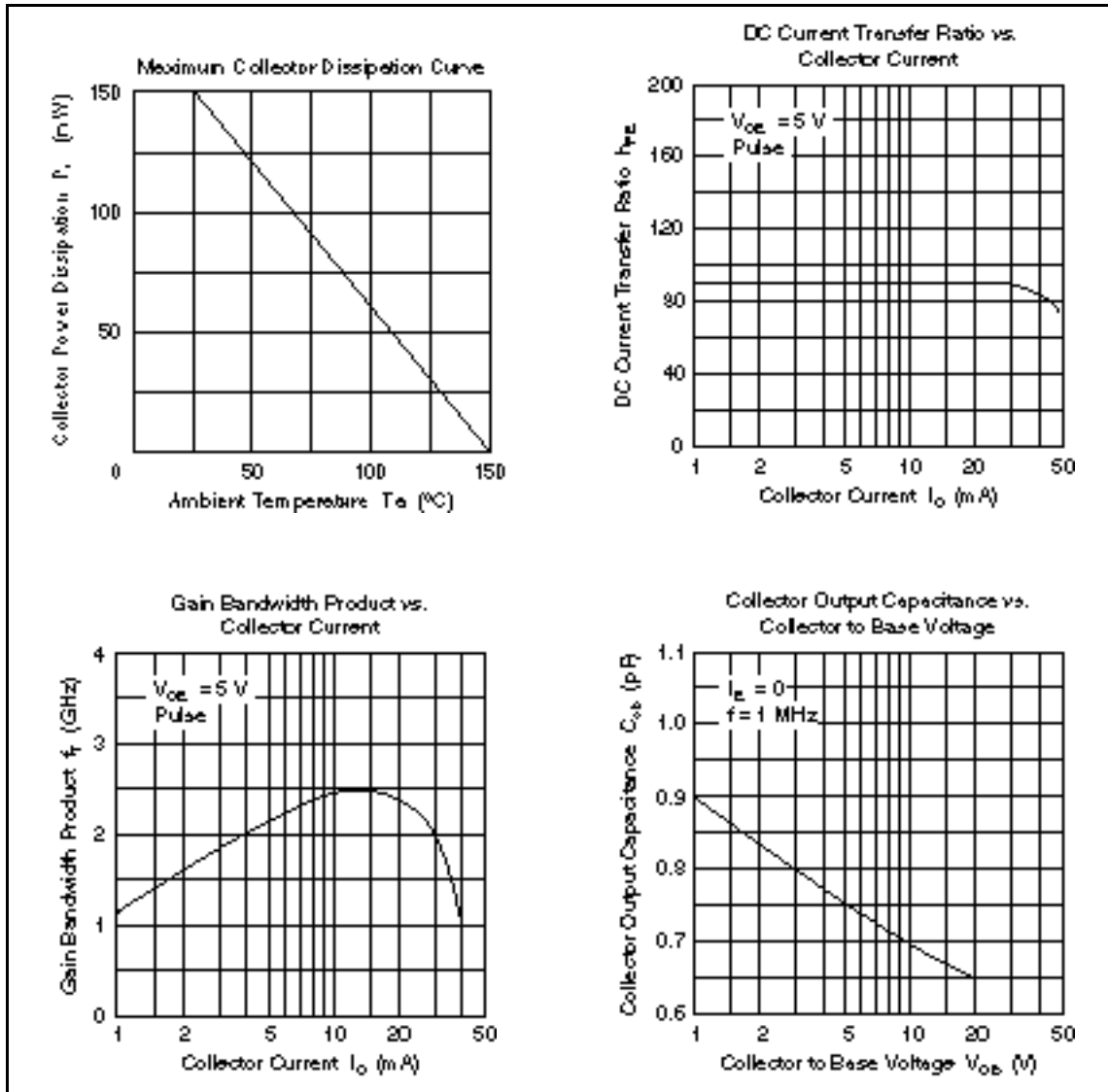

Note: Marking is "QI-".

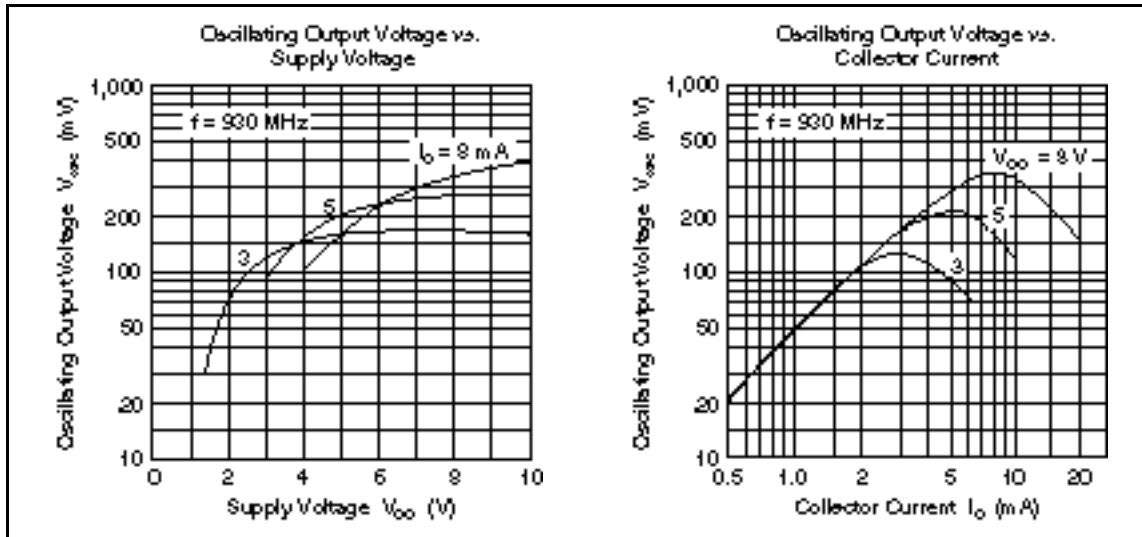

2SC4196

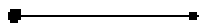

S Parameters (Emitter Common)

Test condition $V_{CE} = 5\text{ V}$, 100 MHz to 1000 MHz (100 MHz STEP), $Z_0 = 50$
 $I_C = 5\text{ mA}$ 
 $I_C = 10\text{ mA}$ 

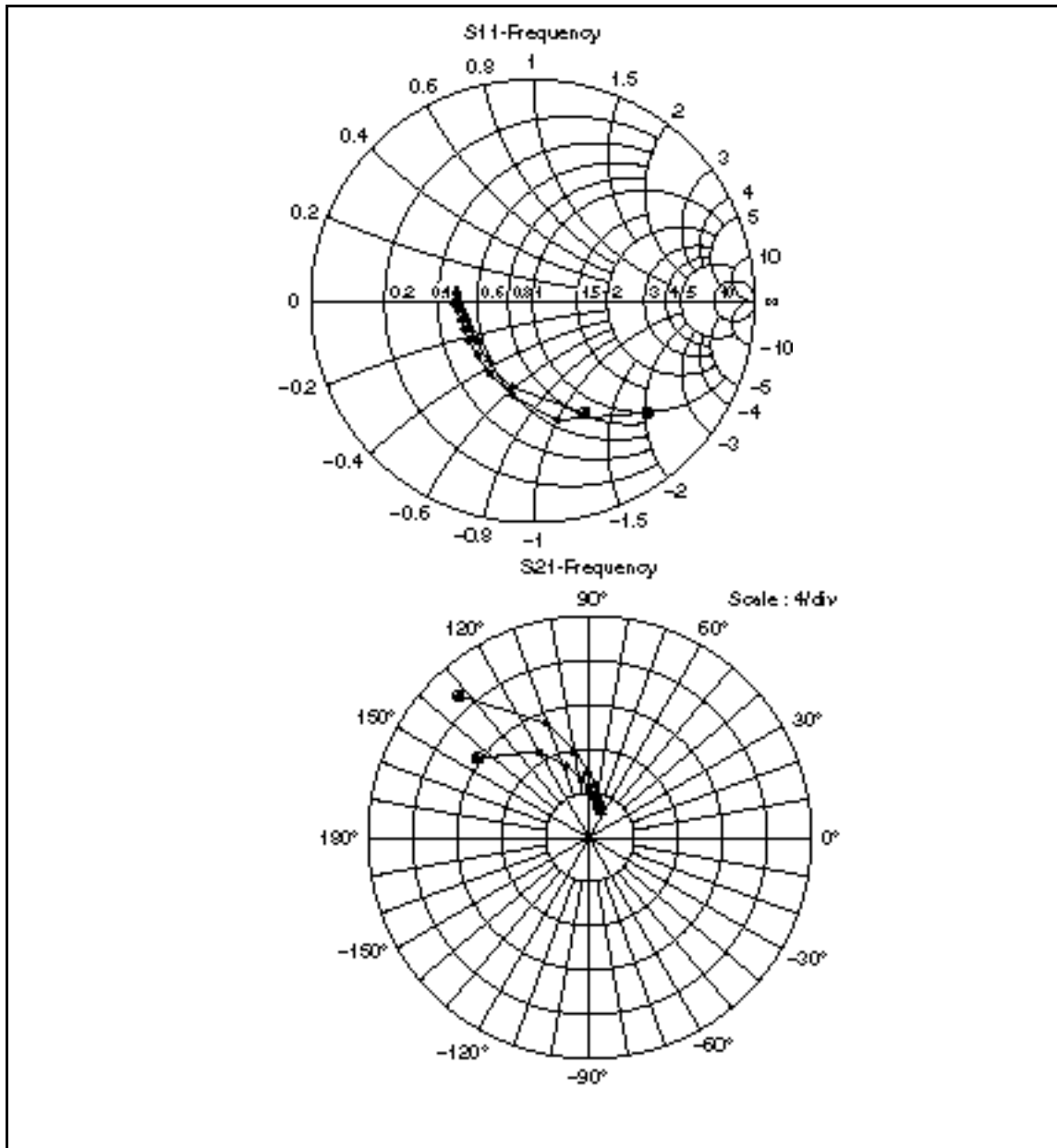

2SC4196

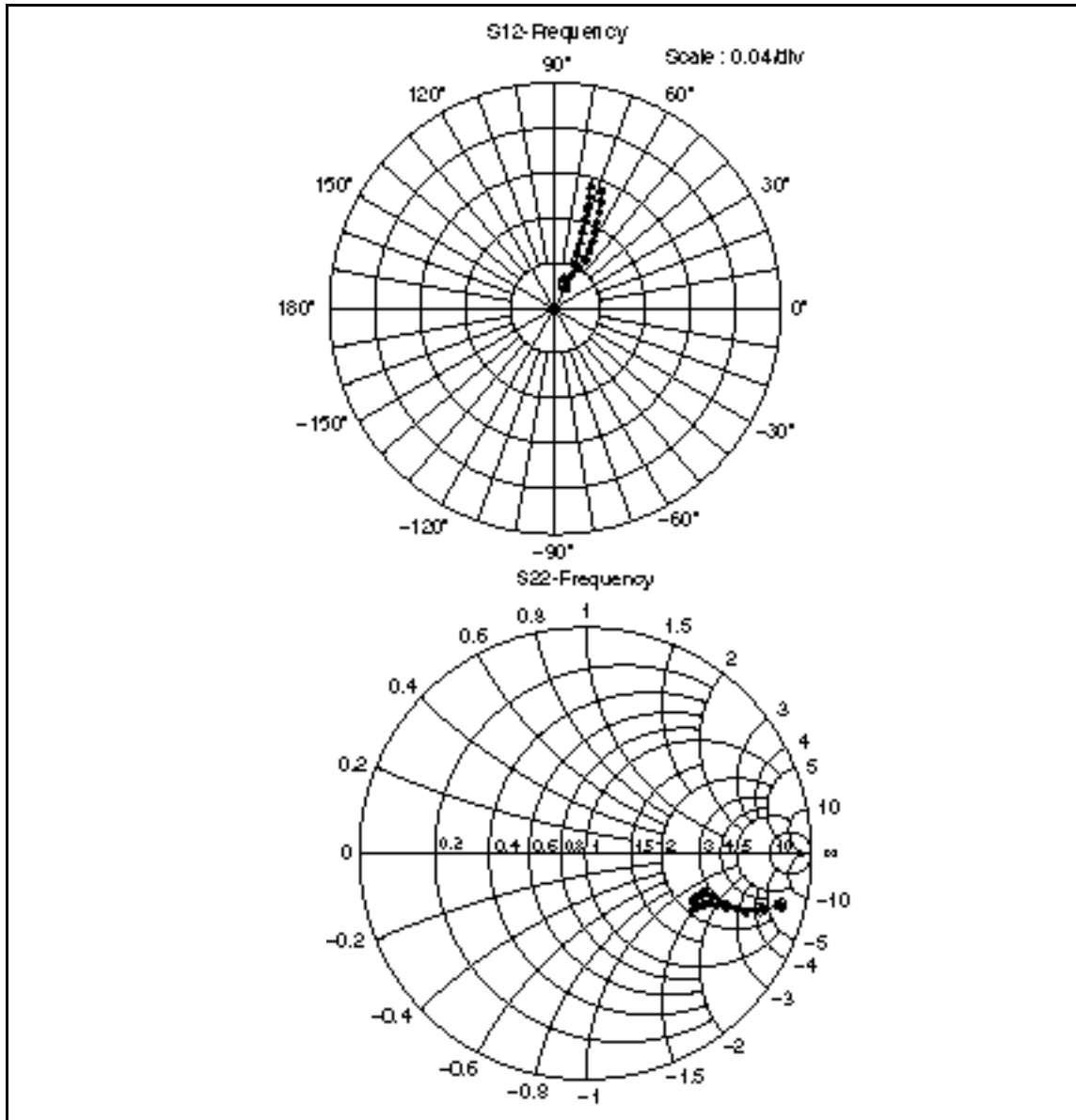

S Parameters (Emitter Common)**Test Condition** $V_{CE} = 5\text{ V}$, $I_C = 5\text{ mA}$, $Z_O = 50$

Freq. (MHz)	S11		S21		S12		S22	
	MAG.	ANG.	MAG.	ANG.	MAG.	ANG.	MAG.	ANG.
100	0.718	-44.8	12.498	144.9	0.026	68.8	0.895	-14.6
200	0.549	-78.8	9.123	122.0	0.042	59.3	0.756	-20.3
300	0.439	-102.0	6.788	108.4	0.051	57.6	0.671	-21.3
400	0.381	-120.8	5.348	99.3	0.060	58.5	0.626	-21.5
500	0.351	-135.5	4.396	92.4	0.068	60.6	0.600	-21.8
600	0.340	-148.2	3.732	86.7	0.076	62.5	0.582	-22.5
700	0.337	-157.8	3.240	81.7	0.085	64.3	0.569	-23.3
800	0.337	-165.2	2.875	77.3	0.094	66.0	0.558	-24.4
900	0.343	-173.1	2.575	73.4	0.103	67.3	0.547	-25.8
1000	0.359	-177.9	2.355	70.0	0.112	68.4	0.538	-27.2

Test Condition $V_{CE} = 5\text{ V}$, $I_C = 10\text{ mA}$, $Z_O = 50$

Freq. (MHz)	S11		S21		S12		S22	
	MAG.	ANG.	MAG.	ANG.	MAG.	ANG.	MAG.	ANG.
100	0.553	-65.2	17.540	133.2	0.022	64.8	0.809	-18.0
200	0.401	-103.4	11.066	111.3	0.033	61.3	0.659	-20.0
300	0.337	-127.4	7.723	99.9	0.043	63.9	0.598	-18.6
400	0.314	-143.9	5.939	92.5	0.052	66.3	0.570	-18.1
500	0.313	-155.7	4.816	86.7	0.063	68.6	0.555	-18.2
600	0.314	-165.5	4.052	81.8	0.073	70.1	0.545	-18.9
700	0.327	-172.2	3.496	77.6	0.083	71.4	0.536	-19.9
800	0.335	-177.7	3.090	73.8	0.093	72.4	0.530	-21.0
900	0.349	176.8	2.753	70.1	0.103	73.0	0.523	-22.4
1000	0.354	172.8	2.515	67.0	0.113	74.0	0.516	-24.0

2SC4196

Y Parameters (Emitter Common)

Test Condition $V_{CE} = 5\text{ V}$, $I_C = 5\text{ mA}$

Freq. (MHz)	Yie (mS)		Yfe (mS)		Yre (mS)		Yoe (mS)	
	REAL	IMAG.	REAL	IMAG.	REAL	IMAG.	REAL	IMAG.
100	3.035	5.491	152.256	-40.168	-0.005	-0.334	0.048	0.613
200	6.463	10.003	131.145	-71.318	-0.015	-0.679	0.100	1.238
300	10.768	12.356	103.025	-90.187	-0.036	-1.034	0.191	1.804
400	15.089	13.186	77.334	-98.666	-0.065	-1.397	0.232	2.386
500	18.776	12.837	55.039	-99.977	-0.090	-1.767	0.270	2.947
600	22.098	11.913	37.290	-98.247	-0.128	-2.134	0.347	3.555
700	24.568	10.731	22.802	-93.799	-0.163	-2.515	0.417	4.133
800	26.291	9.416	11.686	-88.266	-0.193	-2.890	0.516	4.703
900	28.112	7.683	2.225	-82.972	-0.260	-3.305	0.614	5.354
1000	29.685	6.751	-3.931	-78.720	-0.291	-3.746	0.629	5.908

Test Condition $V_{CE} = 5\text{ V}$, $I_C = 10\text{ mA}$

Freq. (MHz)	Yie (mS)		Yfe (mS)		Yre (mS)		Yoe (mS)	
	REAL	IMAG.	REAL	IMAG.	REAL	IMAG.	REAL	IMAG.
100	5.903	7.347	243.307	-103.091	-0.008	-0.338	0.026	0.591
200	11.583	10.820	168.225	-150.806	-0.022	-0.682	0.128	1.254
300	16.546	10.993	103.210	-155.623	-0.045	-1.041	0.216	1.797
400	20.055	10.038	61.965	-145.393	-0.074	-1.387	0.320	2.394
500	22.491	8.943	35.421	-131.365	-0.093	-1.766	0.316	2.917
600	24.417	7.556	16.762	-118.513	-0.133	-2.138	0.378	3.544
700	26.086	6.620	5.096	-107.291	-0.155	-2.531	0.424	4.086
800	27.193	5.569	-3.874	-97.359	-0.185	-2.923	0.469	4.659
900	28.543	4.340	-11.095	-88.952	-0.248	-3.349	0.563	5.307
1000	28.955	3.253	-15.953	-81.466	-0.270	-3.737	0.650	5.861

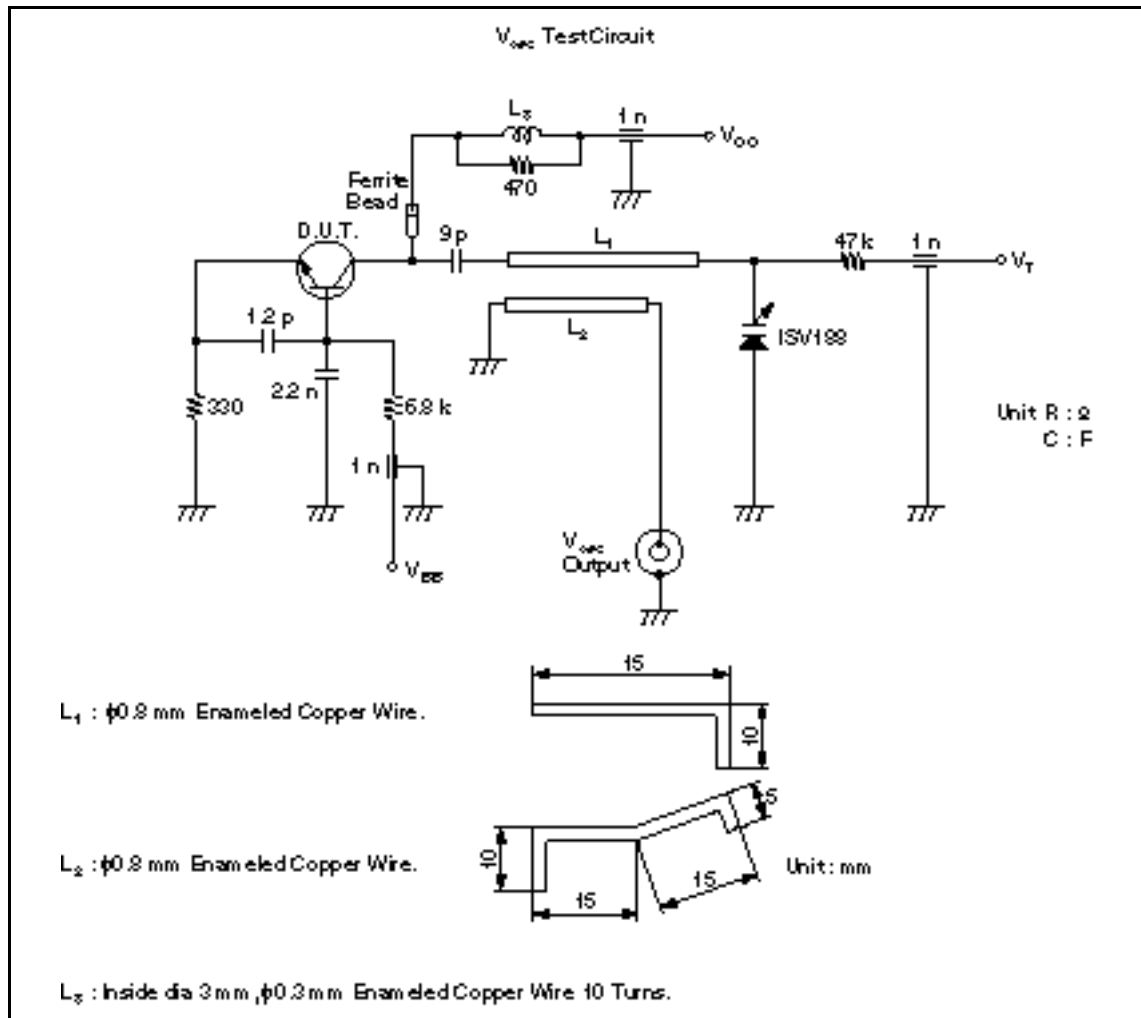
V_{osc} Test Circuit

When using this document, keep the following in mind:

1. This document may, wholly or partially, be subject to change without notice.
2. All rights are reserved: No one is permitted to reproduce or duplicate, in any form, the whole or part of this document without Hitachi's permission.
3. Hitachi will not be held responsible for any damage to the user that may result from accidents or any other reasons during operation of the user's unit according to this document.
4. Circuitry and other examples described herein are meant merely to indicate the characteristics and performance of Hitachi's semiconductor products. Hitachi assumes no responsibility for any intellectual property claims or other problems that may result from applications based on the examples described herein.
5. No license is granted by implication or otherwise under any patents or other rights of any third party or Hitachi, Ltd.
6. **MEDICAL APPLICATIONS:** Hitachi's products are not authorized for use in **MEDICAL APPLICATIONS** without the written consent of the appropriate officer of Hitachi's sales company. Such use includes, but is not limited to, use in life support systems. Buyers of Hitachi's products are requested to notify the relevant Hitachi sales offices when planning to use the products in **MEDICAL APPLICATIONS**.

HITACHI

Hitachi, Ltd.

Semiconductor & IC Div.
Nippon Bldg., 2-6-2, Ohite-machi, Chiyoda-ku, Tokyo 100, Japan
Tel: Tokyo (03) 3270-2111
Fax: (03) 3270-5109

For further information write to:

Hitachi America, Ltd.
Semiconductor & IC Div.
2000 Sierra Point Parkway
Brisbane, CA. 94005-4835
U.S.A.
Tel: 415-589-8300
Fax: 415-589-4207

Hitachi Europe GmbH
Electronic Components Group
Continental Europe
Dornacher StraÙe 3
D-85622 Feldkirchen
München
Tel: 089-9 94 80 0
Fax: 089-9 29 30 00

Hitachi Europe Ltd.
Electronic Components Div.
Northern Europe Headquarters
Whitbrook Park
Lower Cookham Road
M Maidenhead
Berkshire SL6 8YA
United Kingdom
Tel: 0628-585000
Fax: 0628-778322

Hitachi Asia Pte. Ltd.
45 Collyer Quay #20-00
Hitachi Tower
Singapore 0404
Tel: 535-2100
Fax: 535-1533

Hitachi Asia (Hong Kong) Ltd.
Unit 705, North Tower,
World Finance Centre
Harbour City, Canton Road
Tsim Sha Tsui, Kowloon
Hong Kong
Tel: 27359218
Fax: 27308074