2SC4901

Silicon NPN Epitaxial

HITACHI

Application

UHF / VHF wide band amplifier

Features

- High gain bandwidth product
 $f_T = 9 \text{ GHz Typ}$
- High gain, low noise figure
 $PG = 13.0 \text{ dB Typ, NF} = 1.2 \text{ dB Typ at } f = 900 \text{ MHz}$

Outline

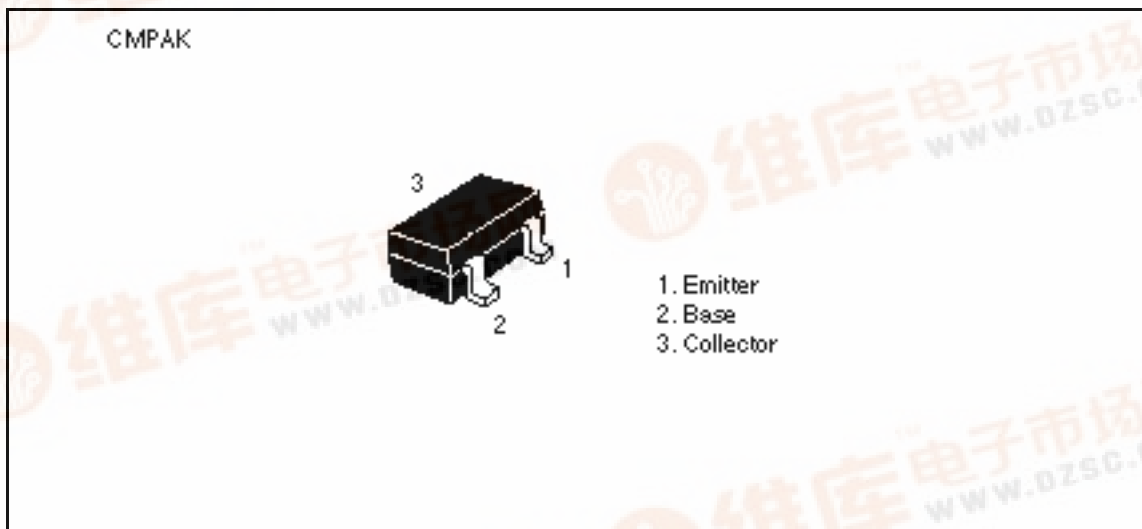

2SC4901

Absolute Maximum Ratings (Ta = 25°C)

Item	Symbol	Ratings	Unit
Collector to base voltage	V_{CBO}	15	V
Collector to emitter voltage	V_{CEO}	9	V
Emitter to base voltage	V_{EBO}	1.5	V
Collector current	I_C	50	mA
Collector power dissipation	P_C	100	mW
Junction temperature	T_j	150	°C
Storage temperature	T_{stg}	-55 to +150	°C

Electrical Characteristics (Ta = 25°C)

Item	Symbol	Min	Typ	Max	Unit	Test conditions
Collector to base breakdown voltage	$V_{(BR)CBO}$	15	—	—	V	$I_C = 10 \mu A, I_E = 0$
Collector cutoff current	I_{CBO}	—	—	10	μA	$V_{CB} = 12 V, I_E = 0$
	I_{CEO}	—	—	1	mA	$V_{CE} = 9 V, R_{BE} =$
Emitter cutoff current	I_{EBO}	—	—	10	μA	$V_{EB} = 1.5 V, I_C = 0$
DC current transfer ratio	h_{FE}	50	120	250		$V_{CE} = 5 V, I_C = 20 mA$
Collector output capacitance	C_{ob}	—	0.9	1.4	pF	$V_{CB} = 5 V, I_E = 0,$ $f = 1 MHz$
Gain bandwidth product	f_T	6.0	9.0	—	GHz	$V_{CE} = 5 V, I_C = 20 mA$
Power gain	PG	10.0	13.0	—	dB	$V_{CE} = 5 V, I_C = 20 mA,$ $f = 900 MHz$
Noise figure	NF	—	1.2	2.5	dB	$V_{CE} = 5 V, I_C = 5 mA,$ $f = 900 MHz$

Note: Marking is "YK-".