

# LMG7420PLFC-X

# 240\*128 Dots

## FEATURES

- ◆ Black on White STN TYPE
- ◆ Transmissive Mode
- ◆ High Brightness CFL Backlight

- ◆ High Contrast LC Material
- ◆ Built-in LCD Controller T6963C

## MECHANICAL DATA

Item	Value	Unit
Module Dimensions	159.4*101*11	mm
Viewing Area	123*68	mm
Resolution	240*128	dots
Dot Size	0.47*0.47	mm
Dot Pitch	0.5*0.5	mm
Weight	180	g

## OPTICAL DATA

Item	Symbol	Condition	Min	Typ	Max	Unit
Contrast Ratio	K	∅=10°, Q=0°, Note 1	-	18	-	-
Brightness	-	T=25°C, IL=5mA, Note 8	60.0	80.0	-	cd/m <sup>2</sup>
Viewing Direction	-	-	6			o'clock
Viewing Angle	∅2 - ∅1	K=2, Note 1	30	40	-	degree
Response Time (Rise)	t <sub>R</sub>	∅=10°, Q=0°, Note 1	-	160	210	ms
Response Time (Fall)	t <sub>F</sub>	∅=10°, Q=0°, Note 1	-	110	160	ms

## ABSOLUTE MAXIMUM RATINGS

Item	Symbol	Condition	Min	Max	Unit
Supply Voltage (Logic)	V <sub>DD</sub> - V <sub>SS</sub>	-	0	6.5	V
Supply Voltage (LC Drive)	V <sub>DD</sub> - V <sub>EE</sub>	-	0	20.5	V
Input Voltage	V <sub>I</sub>	-	-0.3	0.3+V <sub>DD</sub>	V
Operating Temperature	T <sub>OP</sub>	Note 5,6	0	50	°C
Storage Temperature	T <sub>ST</sub>	Note 7	-20	60	°C

## DATA INTERFACE PIN ASSIGNMENT

Pin No	Symbol	Level	Function
A1	VSS (0V)	-	Ground
A2	VDD (+5V)	-	Power supply for logic circuit
A3	V0	-	Power supply for LCD drive
A4	C/D	-	Not WR=Low and C/D=High for Command Write, C/D= Low for Data Write, Not RD = Low and C/D=High for Status Read, C/D = Low for Data Read
A5	Not WR	-	DW=Low for Data Write
A6	Not RD	-	RD=Low for Data read
A7-A14	DB0 - DB7	-	Display data
A15	Not CE	-	Chip enable (Not CE must be Low)
A16	Not RET	-	Reset
A17	VEE (-15V)	-	Power supply for LCD drive
A18	Not DISP OFF	-	NC for Display ON, GND for Display OFF
A19	F/S	-	Character font selection (F/S=High for 6x8 font, F/S=Low for 8x8 font)
A20	Reverse	-	Display mode reverse

## CFL INTERFACE PIN ASSIGNMENT

Pin No	Symbol	Level	Function
1	GND	-	CFL Ground
2	NC	-	No connection
3	NC	-	No connection
4	HV	-	Power supply for CFL

## ELECTRICAL CHARACTERISTICS

Item	Symbol	Condition	Min	Typ	Max	Unit
Supply Voltage (Logic)	V <sub>DD</sub> - V <sub>SS</sub>	-	4.75	5.0	5.25	V
Supply Voltage (LC Drive)	V <sub>EE</sub> - V <sub>SS</sub>	-	-14.5	-15.0	-15.5	V
Supply Current	I <sub>DD</sub>	Note 2	-	11.7	14.0	mA
	I <sub>EE</sub>	Note 2	-	2.5	4.0	mA
Input Voltage (High Level)	V <sub>IH</sub>	High Level	0.8*V <sub>DD</sub>	-	V <sub>DD</sub>	V
Input Voltage (Low Level)	V <sub>IL</sub>	Low Level	0	-	0.2*V <sub>DD</sub>	V
Frame Frequency	f <sub>FLM</sub>	Note 4	-	75	-	Hz
Duty Ratio	-	-	-	1/128	-	-
Recommended LC Drive Voltage	V <sub>DD</sub> - V <sub>O</sub>	Duty=1/128 T=0°C, ∅=10°, Note 3	-	16.9	-	V
		Duty=1/128 T=25°C, ∅=10°, Note 3	-	15.8	-	V
		Duty=1/128 T=50°C, ∅=10°, Note 3	-	15.2	-	V
Backlight Lamp Voltage	V <sub>BL</sub>	T=25°C	-	360	-	Vrms
Backlight Lamp Frequency	f <sub>BL</sub>	T=25°C	30	70	85	kHz
Backlight Lamp Current	I <sub>BL</sub>	T=25°C	2.5	5.0	5.5	mA Arms
Lamp Start Voltage	V <sub>S</sub>	T=25°C, Note 9	(1000)	-	-	V

## TIMING CHARACTERISTICS

Item	Symbol	Min	Typ	Max	Unit
C/D set up time	t <sub>CDS</sub>	100	-	-	ns
C/D hold time	t <sub>CHD</sub>	10	-	-	ns
Not CE, Not RD, Not WR pulse width	Not t <sub>CE</sub> , Not t <sub>RD</sub> , Not t <sub>WR</sub>	80	-	-	ns
Data set up time	t <sub>DS</sub>	80	-	-	ns
Data hold time	t <sub>DH</sub>	40	-	-	ns
Access time	t <sub>ACC</sub>	-	-	150	ns
Output hold time	t <sub>OH</sub>	10	-	50	ns

## INVERTER AND CONNECTORS

Recommended Inverter	Starter Kit
HITACHI INVC191	START74xx
Lamp Connector	Lamp Housing Connector
MITSUMI M63M83-04	M61M73-04, M60-04-30-114P or M60-04-30-134P

- Note1: Definition of optical data, see page 84
- Note 2: f<sub>FRAME</sub>=75Hz, V<sub>DD</sub>-V<sub>0</sub>=15.8V, T<sub>a</sub>=25°C
- Note 3: Recommended LCD driving may fluctuate about +/- 1.0V by each module.
- Note 4: Need to make sure of flickering and rippling of display when setting the FRAME Frequency in your set.
- Note 5: Background colour of the LCD changes depending on temperature. Between 40-50°C optical characteristics of the LCD like contrast and viewing angle change but the display remains readable.
- Note 6: Higher starting voltage of CFL and higher LCD driving voltage are needed while operating at 0°C. The lifetime of CFL will be reduced at 0°C
- Note 7: Storage at -20°C < 48 hr, T<sub>a</sub> at 60°C < 168 hr
- Note 8: Measurement after 10 minutes of CFL operating. Brightness control: 100%
- Note 9: Starting discharge voltage is increased when LCM is operating at lower temperature. Please check the characteristics of inverter before applying.



### MECHANICAL DIMENSIONS

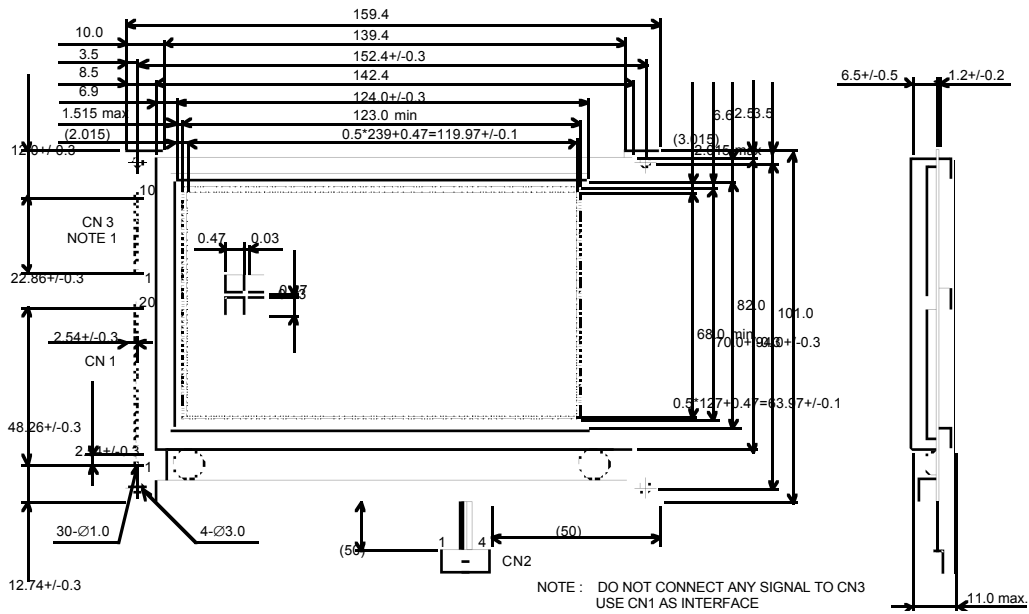

### BLOCK DIAGRAM

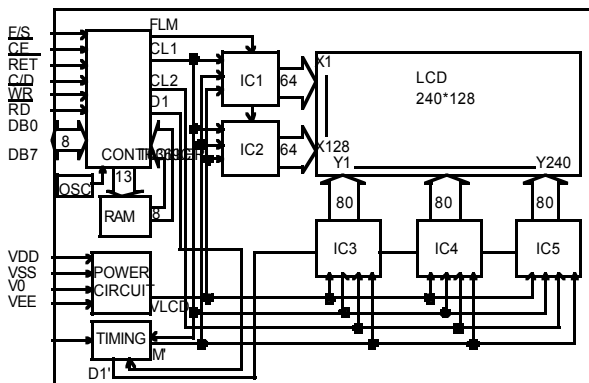

### POWER SUPPLY / POWER UP TIMING DIAGRAM

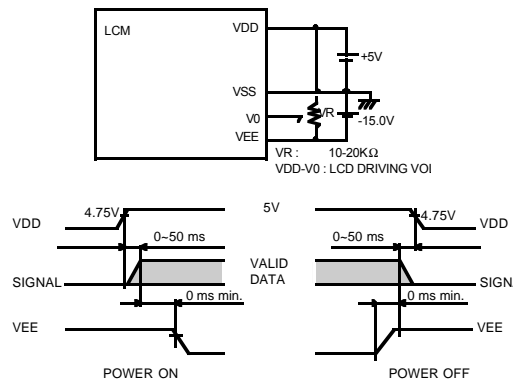

### INTERFACE TIMING DIAGRAM

