



January 2002

LM3485

Hysteretic PFET Buck Controller

General Description

The LM3485 is a high efficiency PFET switching regulator controller that a system designer can use to quickly and easily develop a small, low cost, switching buck regulator for a wide range of applications. The use of a hysteretic control scheme provides for simple design without any control loop stability concerns using a wide variety of external components. The PFET architecture also allows for low component count as well as ultra-low dropout operation. Another benefit is high efficiency operation at light loads without an increase in output ripple. Current limit protection circuit is provided by measuring the voltage across the PFET's $R_{DS(ON)}$ thus eliminating a costly sense resistor. The current limit can be adjusted allowing for designs at various output currents and costs.

Features

- Easy to use control methodology
- No control loop compensation required

- 4.5V to 35V wide input range
- 1.242V to V_{IN} adjustable output range
- High Efficiency 93%
- $\pm 1.3\%$ ($\pm 2\%$ over temp) internal reference
- 100% duty cycle
- Maximum operating frequency > 1MHz
- Current limit protection
- MSOP-8

Applications

- Set-Top Box
- DSL/Cable Modem
- PC/IA
- Auto PC
- TFT Monitor
- Battery Powered Portable Applications
- Distributed Power Systems
- Always On Power

Typical Application Circuit

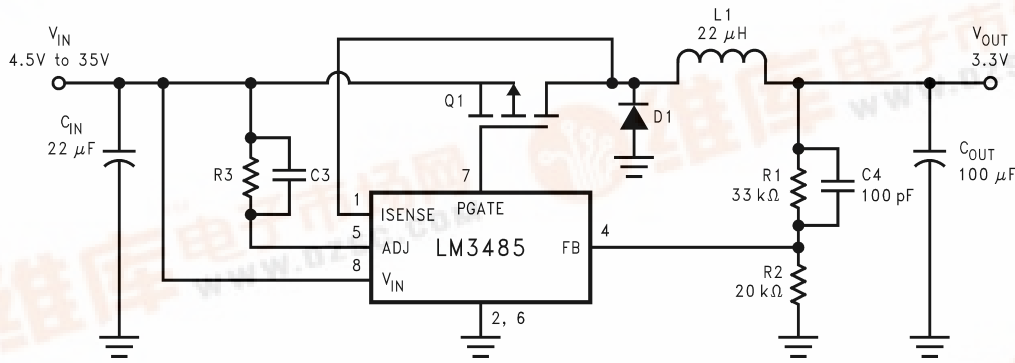

20034608

LM3485 Hysteretic PFET Buck Controller



Connection Diagram

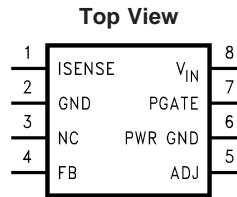

20034609

8 Lead Plastic MSOP-8
NS package Number MUA08A

Package Marking and Ordering Information

Order Number	Package Type	Package Marking	Supplied As:
LM3485MM	MSOP-8	S29B	1000 units on Tape and Reel
LM3485MMX	MSOP-8	S29B	3500 units on Tape and Reel

Pin Description

Pin Name	Pin Number	Description
ISENSE	1	The current sense input pin. This pin should be connected to Drain node of the external PFET.
GND	2	Signal ground.
NC	3	No connection.
FB	4	The feedback input. Connect the FB to a resistor voltage divider between the output and GND for an adjustable output voltage.
ADJ	5	Current limit threshold adjustment. It connects to an internal 5.5 μ A current source. A resistor is connected between this pin and the input Power Supply. The voltage across this resistor is compared with the V _{DS} of the external PFET to determine if an over-current condition has occurred.
PWR GND	6	Power ground.
PGATE	7	Gate Drive output for the external PFET. PGATE swings between V _{IN} and V _{IN} -5V.
VIN	8	Power supply input pin.

Absolute Maximum Ratings (Note 1)

If Military/Aerospace specified devices are required, please contact the National Semiconductor Sales Office/Distributors for availability and specifications.

VIN Voltage	-0.3V to 36V
PGATE Voltage	-0.3V to 36V
FB Voltage	-0.3V to 5V
ISENSE Voltage	-1.0V to 36V
ADJ Voltage	-0.3V to 36V
Maximum Junction Temp.	150°C
Power Dissipation	417mW @ T _A = 25°C

ESD Susceptibility

Human Body Model (Note 3)	2kV
Lead Temperature	
Vapor Phase (60 sec.)	215°C
Infrared (15 sec.)	220°C
Storage Temperature	-65°C to 150°C

Operating Ratings (Note 1)

Supply Voltage	4.5V to 35V
Operating Junction Temperature	-40°C to +125°C

Electrical Characteristics

Specifications in Standard type face are for T_J = 25°C, and in **bold type face** apply over the full **Operating Temperature Range** (T_J = -40°C to +125°C). Unless otherwise specified, V_{IN} = 12V, V_{ISNS} = V_{IN} - 1V, and V_{ADJ} = V_{IN} - 1.1V. Datasheet min/max specification limits are guaranteed by design, test, or statistical analysis.

Symbol	Parameter	Conditions	Min (Note 4)	Typ (Note 5)	Max (Note 4)	Unit
I _Q	Quiescent Current at ground pin	FB = 1.5V (Not Switching)		250	400	μA
V _{FB}	Feedback Voltage (Note 6)		1.226 1.217	1.242	1.258 1.267	V
V _{HYST}	Comparator Hysteresis			10 14	15 20	mV
V _{CL} (Note 7)	Current limit comparator trip voltage	R _{ADJ} = 20kΩ R _{ADJ} = 160kΩ		110 880		mV
V _{CL_OFFSET}	Current limit comparator offset	V _{FB} = 1.5V	-20	0	+20	mV
I _{CL_ADJ}	Current limit ADJ current source	V _{FB} = 1.5V	3.0	5.5	7.0	μA
T _{CL}	Current limit one shot off time	V _{ADJ} = 11.5V V _{ISNS} = 11.0V V _{FB} = 1.0V	6	9	14	μs
R _{PGATE}	Driver resistance	Source I _{SOURCE} = 100mA Sink I _{SINK} = 100mA		5.5 8.5		Ω
I _{PGATE}	Driver Output current	Source V _{IN} = 7V, P _{GATE} = 3.5V Sink V _{IN} = 7V, P _{GATE} = 3.5V		0.44 0.32		A
V _{PGATEMIN}	Minimum driver voltage	V _{IN} = 4.5V V _{FB} = 1.0V I _{GATE} = 100μA sink		1.2		V
I _{FB}	FB pin Bias Current (Note 8)	V _{FB} = 1.0V		300	750	nA
T _{ONMIN_NOR}	Minimum on time in normal operation	V _{ISNS} = V _{ADJ} +0.1V C _{load} on OUT = 1000pF (Note 9)		100		ns

Electrical Characteristics (Continued)

Specifications in Standard type face are for $T_J = 25^\circ\text{C}$, and in **bold type face** apply over the full **Operating Temperature Range** ($T_J = -40^\circ\text{C}$ to $+125^\circ\text{C}$). Unless otherwise specified, $V_{IN} = 12\text{V}$, $V_{ISNS} = V_{IN} - 1\text{V}$, and $V_{ADJ} = V_{IN} - 1.1\text{V}$. Datasheet min/max specification limits are guaranteed by design, test, or statistical analysis.

Symbol	Parameter	Conditions	Min (Note 4)	Typ (Note 5)	Max (Note 4)	Unit
T_{ONMIN_CL}	Minimum on time in current limit	$V_{ISNS} = V_{ADJ} + 0.1\text{V}$ $V_{FB} = 1.0\text{V}$ C_{load} on $OUT = 1000\text{pF}$ (Note 9)		175		ns
$\%V_{FB}/\Delta V_{IN}$	Feedback Voltage Line Regulation	$4.5 \leq V_{IN} \leq 35\text{V}$		0.010		%/V

Note 1: Absolute maximum ratings are limits beyond which damage to the device may occur. Operating Ratings are conditions for which the device is intended to be functional, but device parameter specifications may not be guaranteed. For guaranteed specifications and test conditions, see the Electrical Characteristics.

Note 2: The maximum allowable power dissipation is a function of the maximum junction temperature, T_{J_MAX} , the junction-to-ambient thermal resistance, $\theta_{JA} = 240^\circ\text{C/W}$, and the ambient temperature, T_A . The maximum allowable power dissipation at any ambient temperature is calculated using:

$P_{D_MAX} = (T_{J_MAX} - T_A)/\theta_{JA}$. Exceeding the maximum allowable power dissipation will cause excessive die temperature.

Note 3: The human body model is a 100 pF capacitor discharged through a 1.5k Ω resistor into each pin.

Note 4: All limits are guaranteed at room temperature (standard type face) and at **temperature extremes (bold type face)**. All room temperature limits are 100% tested. All limits at **temperature extremes** are guaranteed via correlation using standard Statistical Quality Control (SQC) methods. All limits are used to calculate Average Outgoing Quality Level (AOQL).

Note 5: Typical numbers are at 25°C and represent the most likely norm.

Note 6: The V_{FB} is the trip voltage at the FB pin when PGATE switches from high to low.

Note 7: $V_{CL} = I_{CL_ADJ} * R_{ADJ}$

Note 8: Bias current flows out from the FB pin.

Note 9: A 1000pF capacitor is connected between V_{IN} and PGATE.

Typical Performance Characteristics

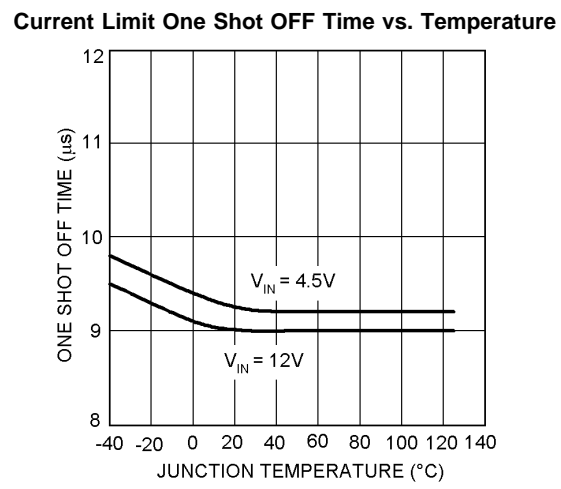
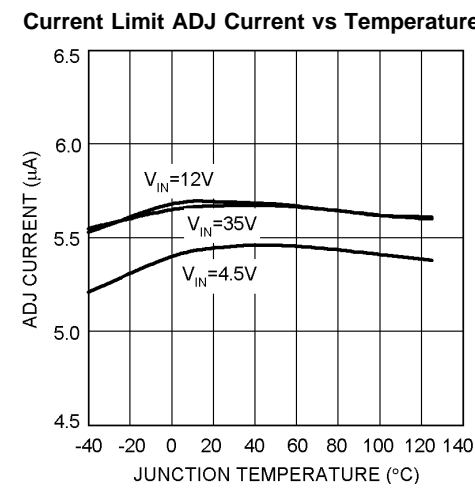
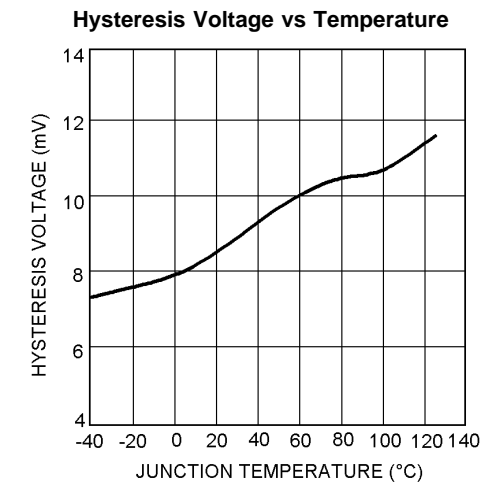
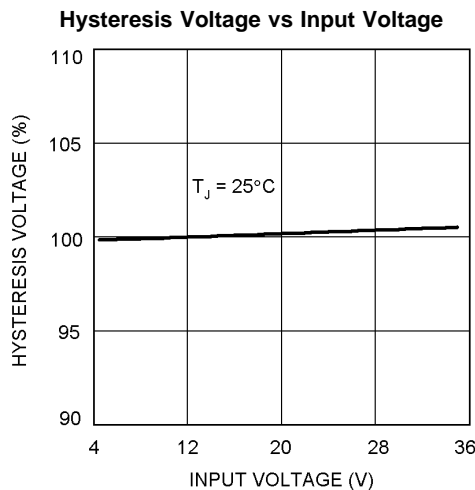
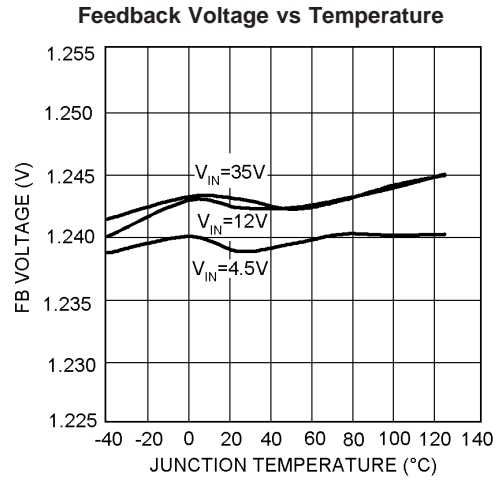
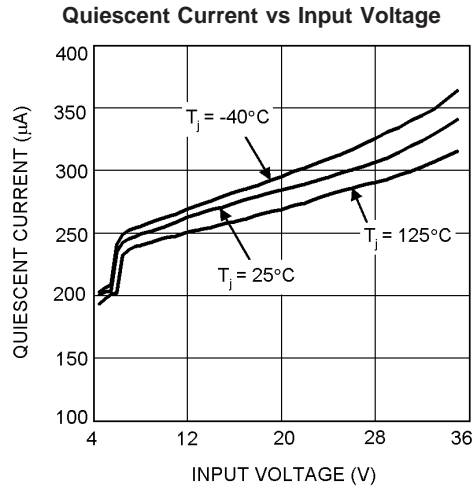

Typical Performance Characteristics (Continued)

PGATE Voltage vs Input Voltage

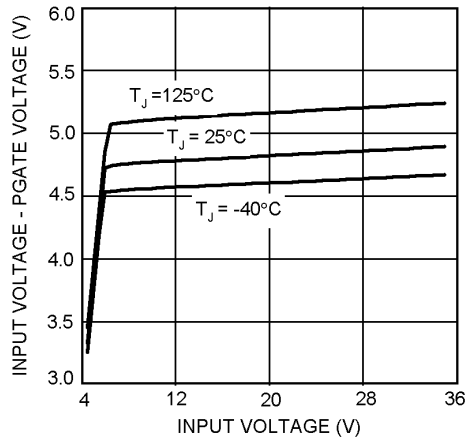

20034603

Minimum ON Time vs. Temperature

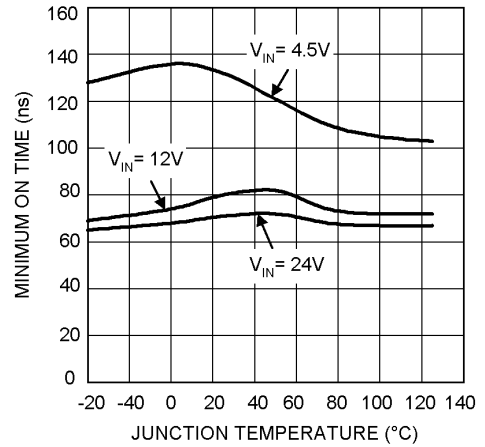

20034612

Operating ON Time vs Output Load Current

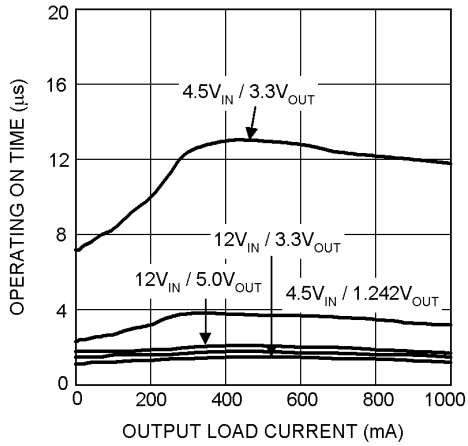

20034622

Efficiency vs Load Current (3.3 V_{OUT}, 6.8µH)

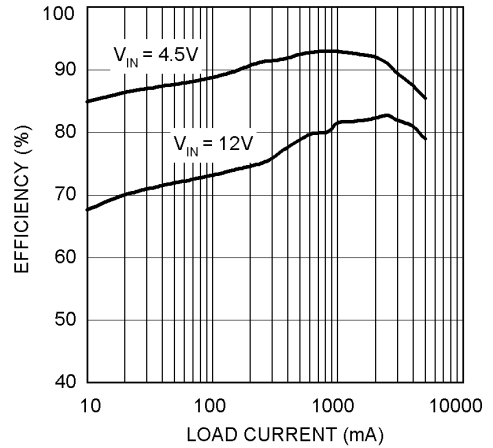

20034617

Efficiency vs Load Current (3.3 V_{OUT}, 22µH)

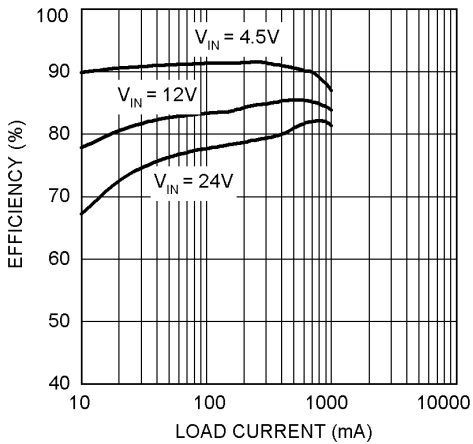

20034618

Efficiency vs Load Current (5.0 V_{OUT}, 22µH)

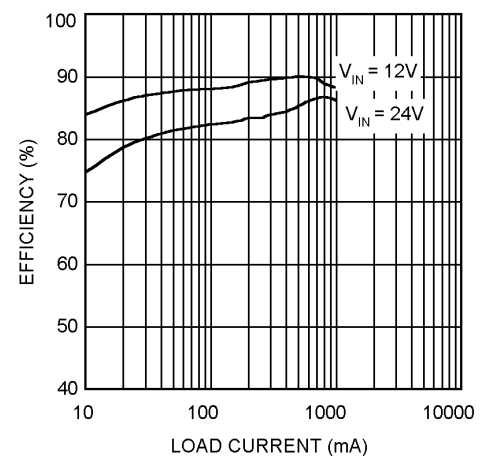

20034631

Typical Performance Characteristics (Continued)

Continuous Mode Operation
(12 V_{IN}, 3.3 V_{OUT}, 500mA Load, 22μH)

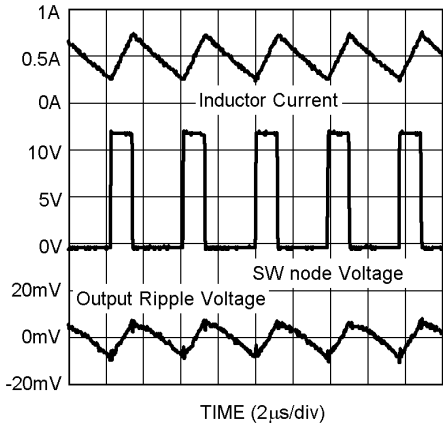

20034615

Discontinuous Mode Operation
(12 V_{IN}, 3.3 V_{OUT}, 50mA Load, 22μH)

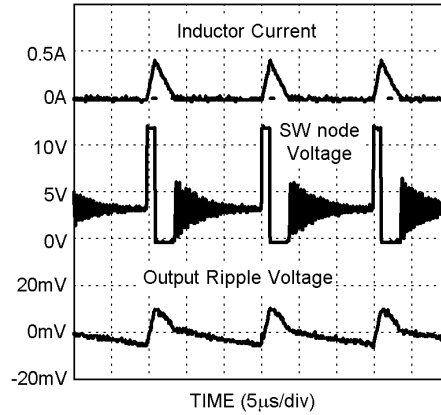

20034616

Start Up

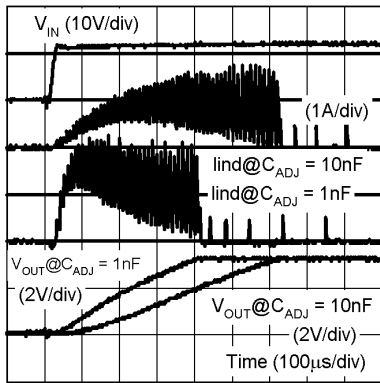

20034620

Operating Frequency and Output Ripple Voltage vs Input Voltage

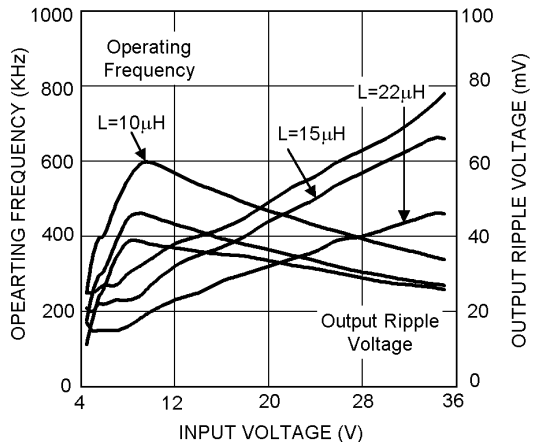

20034613

Operating Frequency vs Output Load Current

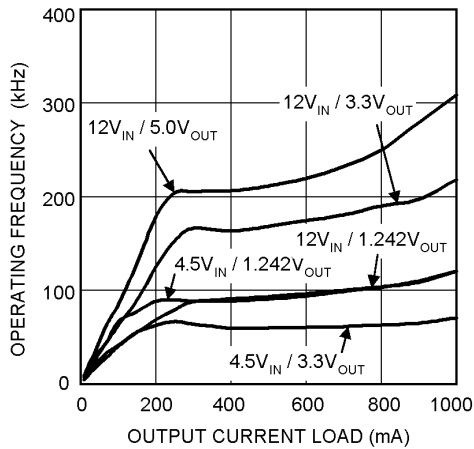

20034621

Feed-Forward Capacitor (C_{ff}) Effect

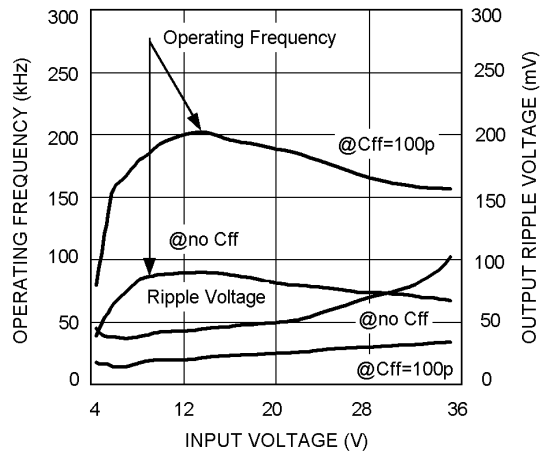

20034630

Block Diagram

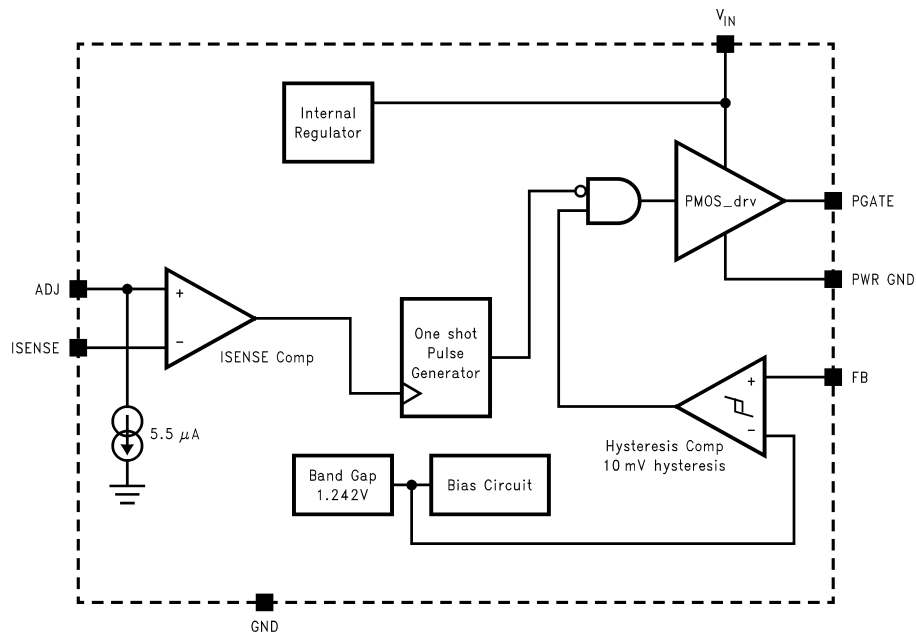

20034610

Functional Description

Overview

The LM3485 is buck (step-down) DC-DC controller that uses a hysteretic control scheme. The comparator is designed with approximately 10mV of hysteresis. In response to the voltage at the FB pin, the gate drive (PGATE pin) turns the external PFET on or off. When the inductor current is too high, the current limit protection circuit engages and turns the PFET off for approximately 9μs.

The hysteretic control does not provide an internal oscillator. Switching frequency depends on the external components and operating conditions. Operating frequency reduces at light loads resulting in excellent efficiency compared to other architectures.

2 external resistors can easily program the output voltage. The output can be set in a wide range from 1.242V to V_{IN} .

Hysteretic Control Circuit

The LM3485 uses a comparator based voltage control loop. The feedback is compared to a 1.242V reference and a 10mV hysteresis is designed into the comparator to ensure noise free operation.

When the FB input to the comparator falls below the reference voltage, the output of the comparator moves to a low state. This results in the driver output, PGATE, pulling the gate of the PFET low and turning on the PFET. With the PFET on, the input supply charges C_{out} and supplies current to the load via the series path through the PFET and the inductor. Current through the Inductor ramps up linearly and the output voltage increases. As the FB voltage reaches the upper threshold, which is the internal reference voltage plus 10mV, the output of the comparator changes from low to high, and the PGATE responds by turning the PFET off. As the PFET turns off, the inductor voltage reverses, the catch diode turns on, and the current through the inductor ramps down. Then, as the output voltage reaches the internal reference voltage again, the next cycle starts.

The LM3485 operates in discontinuous conduction mode at light load current or continuous conduction mode at heavy load current. In discontinuous conduction mode, current through the inductor starts at zero and ramps up to the peak, then ramps down to zero. Next cycle starts when the FB voltage reaches the internal voltage. Until then, the inductor current remains zero. Operating frequency is lower and switching losses reduce. In continuous conduction mode, current always flows through the inductor and never ramps down to zero.

The output voltage (V_{OUT}) can be programmed by 2 external resistors. It can be calculated as following.

$$V_{OUT} = 1.242 * (R1 + R2) / R2$$

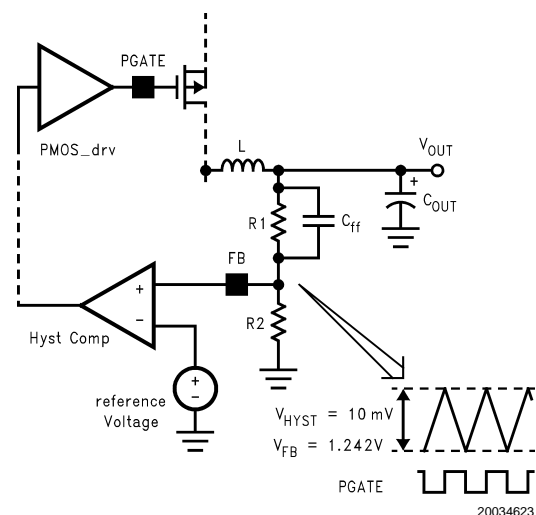

20034623

FIGURE 1. Hysteretic Window

The minimum output voltage ripple (V_{OUT_PP}) can be calculated in the same way.

$$V_{RIPPLE} = V_{HYST} (R1 + R2) / R2$$

Functional Description (Continued)

For example, with V_{OUT} set to 3.3V, V_{OUT_PP} is 26.6mV

$$V_{RIPPLE} = 0.01 * (33K + 20K) / 20K = 0.0266V$$

Operating frequency is determined by knowing the input voltage, output voltage, inductor, V_{HYST} , ESR (Equivalent Series Resistance) of output capacitor, and the delay. It can be approximately calculated using the formula:

$$F = \frac{V_{OUT}}{V_{IN}} * \frac{(V_{IN} - V_{OUT}) * ESR}{(V_{HYST} * \alpha * L) + (V_{IN} * delay * ESR)}$$

$$\alpha: (R1 + R2) / R2$$

delay: It includes the LM3485 propagation delay time and the PFET delay time. The propagation delay is 90ns typically. (See the Propagation Delay curve below.)

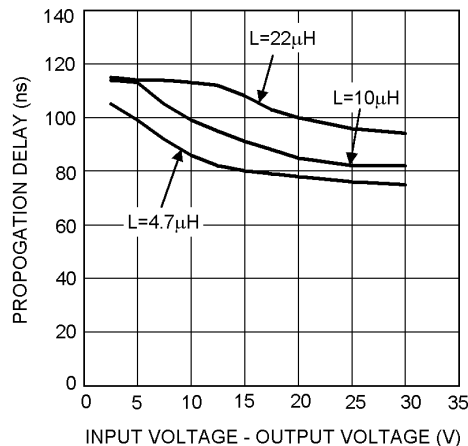

FIGURE 2. Propagation Delay

The operating frequency and output ripple voltage can also be significantly influenced by the speed up capacitor (C_{ff}). C_{ff} is connected in parallel with the high side feedback resistor, R1. The location of this capacitor is similar to where a feed forward capacitor would be located in a PWM control scheme. However its effect on hysteretic operation is much different. The output ripple causes a current to be sourced or sunk through this capacitor. This current is essentially a square wave. Since the input to the feedback pin, FB, is a high impedance node, the current flows through R2. The end result is a reduction in output ripple and an increase in operating frequency. When adding C_{ff} , calculate the formula above with $\alpha = 1$. The value of C_{ff} depend on the desired operating frequency and the value of R2. A good starting point is 470pF ceramic at 100kHz decreasing linearly with increased operating frequency. Also note that as the output voltage is programmed below 2.5V, the effect of C_{ff} will decrease significantly.

Current Limit Operation

The LM3485 has a cycle-by-cycle current limit. Current limit is sensed across the V_{DS} of the PFET or across an additional sense resistor. When current limit is reached, the LM3485 turns off the external PFET for a period of 9µs. The current limit is adjusted by an external resistor, R_{ADJ} .

The current limit circuit is composed of the ISENSE comparator and the one-shot pulse generator. The positive input

of the ISENSE comparator is the ADJ pin. An internal 5.5µA current sink creates a voltage across the external R_{ADJ} resistor. This voltage is compared to the voltage across the PFET or sense resistor. The ADJ voltage can be calculated as follows.

$$V_{ADJ} = V_{IN} - (R_{ADJ} * 5.5\mu A)$$

The negative input of the ISENSE comparator is the ISENSE pin that should be connected to the drain of the external PFET. The inductor current is determined by sensing the V_{DS} . It can be calculated as follows.

$$V_{ISENSE} = V_{IN} - (R_{DSON} * I_{IND_PEAK}) = V_{IN} - V_{DS}$$

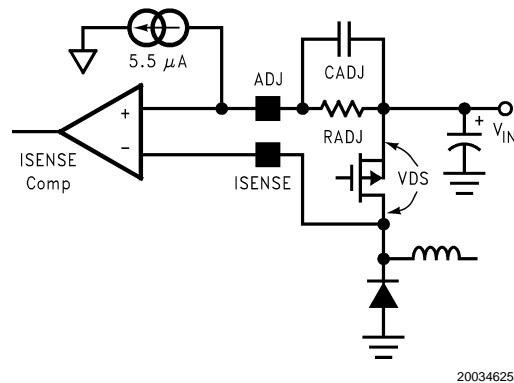

FIGURE 3. Current Sensing by V_{DS}

The current limit is activated when the voltage at the ISENSE pin exceeds the voltage at the ADJ pin. The ISENSE comparator triggers the 9µs one shot pulse generator forcing the driver to turn the PFET off. The driver turns the PFET back on after 9µs. If the current has not reduced below the set threshold, the cycle will repeat continuously.

During current limit operating the output voltage will drop significantly as will operating frequency. As the load current is reduced, the output will return to the programmed voltage. However, there is a current limit fold back phenomenon inherent in this current limit architecture. See Figure 4.

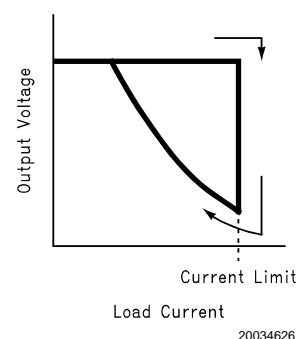

FIGURE 4. Current Limit Fold Back Phenomenon

Start Up

The current limit circuit is active during start-up. During start-up the PFET will stay on until either the current limit or the feedback comparator is tripped

If the current limit comparator is tripped first then the fold back characteristic should be taken into account. Start-up into full load may require a higher current limit set point or the load must be applied after start-up.

Functional Description (Continued)

One problem with selecting a higher current limit is inrush current during start-up. Adding a capacitance (C_{ADJ}) in parallel with R_{ADJ} results in soft-start. C_{ADJ} and R_{ADJ} create an RC time constant forcing current limit to activate at a lower current. The output voltage will ramp more slowly when using the soft-start functionality.

The C_{ADJ} also filters unwanted noise so that the ISENSE comparator will not be accidentally triggered. A value of 100pF to 1nF is recommended in most applications. These low values for C_{ADJ} will have little to no effect on soft-start. There are example start-up plots for C_{ADJ} equal to 1nF and 10nF in the Typical Performance Characteristics.

External Sense Resistor

The V_{DS} of a PFET will tend to vary significantly over temperature. This will result an equivalent variation in current limit. To improve current limit accuracy an external sense resistor can be connected from V_{IN} to the source of the PFET, as shown in *Figure 5*.

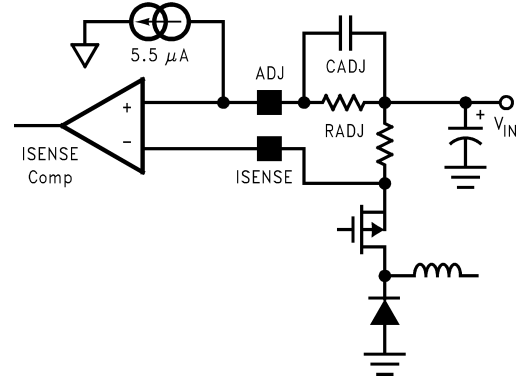

20034627

FIGURE 5. Current Sensing by External Resistor

Design Information

Hysteretic control is a simple control scheme. However the operating frequency and other performance characteristics highly depend on external conditions and components. If either the inductance, output capacitance, ESR, V_{IN} , or C_{ff} is changed, there will be a change in the operating frequency and output ripple. The best approach is to determine what operating frequency is desirable in the application and then begin with the selection of the inductor and C_{OUT} ESR.

Inductor Selection (L1)

The important parameters for the inductor are the inductance and the current rating. The LM3485 operates over a wide frequency range and can use a wide range of inductance values. A good rule of thumb is to use the equations used for National's **Simple Switchers**[®]. The equation for inductor ripple as a function of output current is:

$$\begin{aligned} &\text{for } i_{out} < 2.0\text{Amps} \\ &\Delta i \leq i_{out} \cdot 0.386827 \cdot i_{out}^{-.366726} \\ &\text{for } i_{out} > 2.0\text{Amps} \\ &\Delta i \leq i_{out} \cdot 0.3 \end{aligned}$$

The inductance can be calculated based upon the desired operating frequency where:

$$L = \frac{V_{IN} - V_{DS} - V_{OUT}}{\Delta i} \cdot \frac{D}{f}$$

And

$$D = \frac{V_{OUT} + V_D}{V_{IN} - V_{DS} + V_D}$$

where V_D is diode forward voltage.

The inductor should be rated to the following:

$$I_{pk} = (I_{out} + \Delta i / 2) \cdot 1.1$$

$$I_{RMS} = \sqrt{I_{out}^2 + \frac{\Delta i^2}{3}}$$

The inductance value and the resulting ripple is one of the key parameters controlling operating frequency. The second is the ESR.

Output Capacitor Selection (C_{OUT})

The ESR of the output capacitor times the inductor ripple current is equal to the output ripple of the regulator. However, the V_{HYST} sets the first order value of this ripple. As ESR is increased with a given inductance, then operating frequency increases as well. If ESR is reduced then the operating frequency reduces.

The use of ceramic capacitors has become a common desire of many power supply designers. However, ceramic capacitors have a very low ESR resulting in a 90° phase shift of the output voltage ripple. This results in low operating frequency and increased output ripple. To fix this problem a low value resistor should be added in series with the ceramic output capacitor. Although counter intuitive, this combination of a ceramic capacitor and external series resistance provide highly accurate control over the output voltage ripple. The other types capacitor, such as Sanyo POS CAP and

OS-CON, Panasonic SP CAP, Nichicon 'NA' series, are also recommended and may be used without additional series resistance.

For all practical purposes, any type of output capacitor may be used with proper circuit verification.

Input Capacitor Selection (C_{IN})

A bypass capacitor is required between the input source and ground. It must be located near the source pin of the external PFET. The input capacitor prevents large voltage transients at the input and provides the instantaneous current when the PFET turns on.

The important parameters for the input capacitor are the voltage rating and the RMS current rating. Follow the manufacturer's recommended voltage derating. For high input voltage application, low ESR electrolytic capacitor, the Nichicon 'UD' series or the Panasonic 'FK' series, is available. The RMS current in the input capacitor can be calculated.

$$I_{RMS_CIN} = I_{OUT} \cdot \frac{(V_{OUT} \cdot (V_{IN} - V_{OUT}))^{1/2}}{V_{IN}}$$

The input capacitor power dissipation can be calculated as follows.

$$P_{D(CIN)} = I_{RMS_CIN}^2 \cdot ESR_{CIN}$$

The input capacitor must be able to handle the RMS current and the P_D . Several input capacitors may be connected in parallel to handle large RMS currents. In some cases it may be much cheaper to use multiple electrolytic capacitors than a single low ESR, high performance capacitor such as OS-CON or Tantalum. The capacitance value should be selected such that the ripple voltage created by the charge and discharge of the capacitance is less than 10% of the total ripple across the capacitor.

Programming the Current Limit (R_{ADJ})

The current limit is determined by connecting a resistor (R_{ADJ}) between input voltage and the ADJ pin.

$$R_{ADJ} = I_{IND_PEAK} \cdot R_{DSON} / I_{CL_ADJ}$$

R_{DSON} : Drain-Source ON resistance of the external PFET

I_{CL_ADJ} : 5.5μA typically

$$I_{IND_PEAK} = I_{LOAD} + I_{RIPPLE} / 2$$

Catch Diode Selection

The important parameters for the catch diode are the peak current, the peak reverse voltage, and the average power dissipation. The average current through the diode can be calculated as following.

$$I_{D_AVE} = I_{OUT} \cdot (1 - D)$$

The off state voltage across the catch diode is approximately equal to the input voltage. The peak reverse voltage rating must be greater than input voltage. In nearly all cases a shottky diode is recommended. In low output voltage applications a low forward voltage provides improved efficiency. For high temperature applications, diode leakage current may become significant and require a higher reverse voltage rating to achieve acceptable performance.

Design Information (Continued)

P-Channel MOSFET Selection (Q1)

The important parameters for the PFET are the maximum Drain-Source voltage (V_{DS}), the on resistance ($R_{DS(ON)}$), Current rating, and the input capacitance.

The voltage across the PFET when it is turned off is equal to the sum of the input voltage and the diode forward voltage. The V_{DS} must be selected to provide some margin beyond the input voltage. PGATE swings the PFET's gate from V_{IN} to $V_{IN} - 5V$ when the input voltage is greater than 7V. At less than 7V input, the PGATE voltage swing is smaller. At 4.5V input the PGATE swings from V_{IN} to $V_{IN} - 3.3V$. To insure that the PFET turns on completely, a low threshold PFET should be used when the input voltage is less than 7V. $R_{DS(ON)}$ and package size must be used to determine the appropriate FET for a given current as well as peak current capability. Switching losses also must be considered.

The first order losses in the FET are approximately:

$$P_{Dswitch} = R_{DS(ON)} * I_{OUT}^2 * D + f * I_{OUT} * V_{IN} * (ton + toff) / 2$$

Where:

ton = FET turn on time

$toff$ = FET turn off time

A value of 10ns to 20ns is typical for ton and $toff$.

The $R_{DS(ON)}$ is used in determining the current limit resistor value, R_{ADJ} . Note that the $R_{DS(ON)}$ has a positive temperature coefficient. At 100°C, the $R_{DS(ON)}$ may be as much as 150% higher than the 25°C value. This increase in $R_{DS(ON)}$ must be considered it when determining R_{ADJ} in wide temperature

range applications. If the current limit is set based upon 25°C ratings, then false current limiting can occur at high temperature.

Keeping the gate capacitance below 2000pF is recommended to keep switching losses and transition times low. As gate capacitance increases, operating frequency should be reduced and as gate capacitance decreases operating frequency can be increased.

PCB Layout

The PCB layout is very important in all switching regulator designs. Poor layout can cause switching noise into the feedback signal and general EMI problems. For minimal inductance, the wires indicated by heavy lines should be as wide and short as possible. Keep the ground pin of the input capacitor as close as possible to the anode of the diode. This path carries a large AC current. The switching node, the node with the diode cathode, inductor, and FET drain, should be kept short. This node is one of the main sources for radiated EMI since it is an AC voltage at the switching frequency. It is always good practice to use a ground plane in the design, particularly at high currents. The gate pin of the external PFET should be located close to the PGATE pin. However, if a very small FET is used, a resistor may be required between PGATE and the gate of the FET to reduce high frequency ringing.

The feedback voltage signal line can be sensitive to noise. Make sure to avoid inductive coupling to the inductor or the switching node.

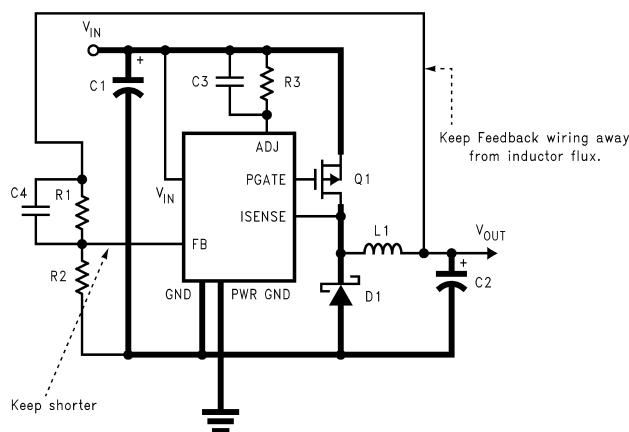

20034628

FIGURE 6. Typical PCB Layout Schematic (3.3V output)

Physical Dimensions inches (millimeters)

unless otherwise noted

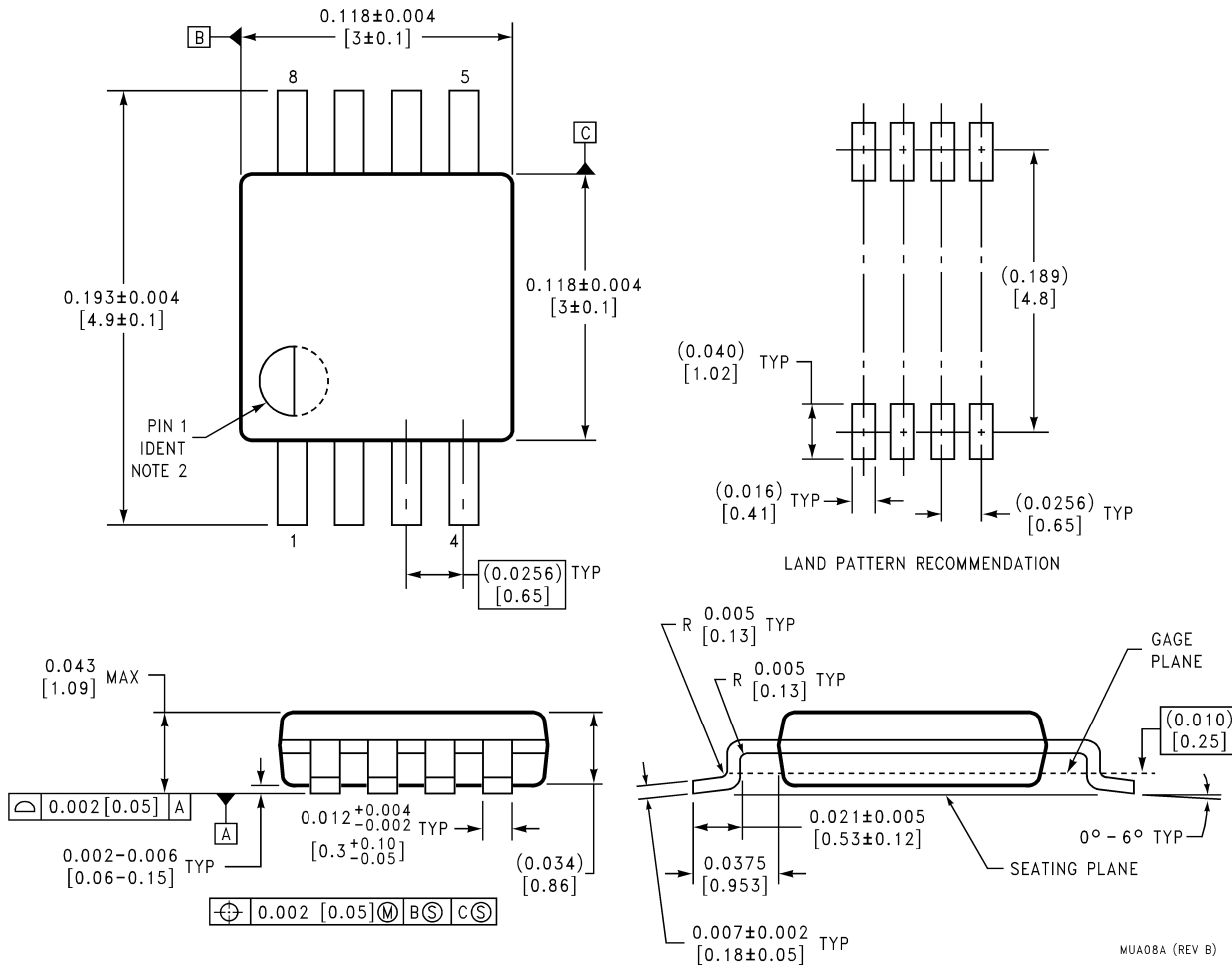

**8 Lead Plastic MSOP-8
NS package Number MUA08A**

LIFE SUPPORT POLICY

NATIONAL'S PRODUCTS ARE NOT AUTHORIZED FOR USE AS CRITICAL COMPONENTS IN LIFE SUPPORT DEVICES OR SYSTEMS WITHOUT THE EXPRESS WRITTEN APPROVAL OF THE PRESIDENT AND GENERAL COUNSEL OF NATIONAL SEMICONDUCTOR CORPORATION. As used herein:

1. Life support devices or systems are devices or systems which, (a) are intended for surgical implant into the body, or (b) support or sustain life, and whose failure to perform when properly used in accordance with instructions for use provided in the labeling, can be reasonably expected to result in a significant injury to the user.
2. A critical component is any component of a life support device or system whose failure to perform can be reasonably expected to cause the failure of the life support device or system, or to affect its safety or effectiveness.

National Semiconductor Corporation
Americas
Email: support@nsc.com

National Semiconductor Europe
Fax: +49 (0) 180-530 85 86
Email: europe.support@nsc.com
Deutsch Tel: +49 (0) 69 9508 6208
English Tel: +44 (0) 870 24 0 2171
Français Tel: +33 (0) 1 41 91 8790

National Semiconductor Asia Pacific Customer Response Group
Tel: 65-2544466
Fax: 65-2504466
Email: ap.support@nsc.com

National Semiconductor Japan Ltd.
Tel: 81-3-5639-7560
Fax: 81-3-5639-7507

www.national.com