

# NCP1800

## Single-Cell Lithium Ion Battery Charge Controller

The NCP1800 is a constant current, constant voltage (CCCV) lithium ion battery charge controller. The external sense resistor sets the full charging current, and the termination current is 10% of the full charge current (0.1 C). The voltage is regulated at  $\pm 1\%$  during the final charge stage. There is virtually zero drain on the battery when the input power is removed.

### Features

- Integrated Voltage and Programmable Current Regulation
- Integrated Cell Conditioning for Deeply Discharged Cell
- Integrated End of Charge Detection
- Better than 1% Voltage Regulation
- Charger Status Output for LED or Host Processor Interface
- Charge Interrupt Input
- Safety Shutoff for Removal of Battery
- Blocking Diode Not Required with PNP Transistor
- Adjustable Charge Current Limit
- Input Over and Under Voltage Lockout
- Micro8 Package

### Applications

- Cellular Phones, PDAs
- Handheld Equipments
- Battery Operated Portable Devices



ON Semiconductor™

<http://onsemi.com>

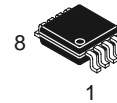

Micro8™  
CASE 846A  
DM SUFFIX

### PIN CONNECTIONS AND MARKING DIAGRAM

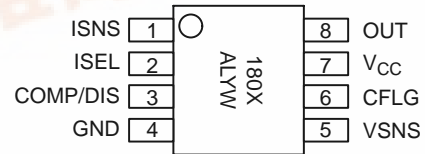

X = A for 41 Device  
B for 42 Device  
A = Assembly Location  
L = Wafer Lot  
Y = Year  
W = Work Week

### ORDERING INFORMATION

Device	Package	Shipping
NCP1800DM41R2	Micro8	4000 Units/Reel
NCP1800DM42R2	Micro8	4000 Units/Reel

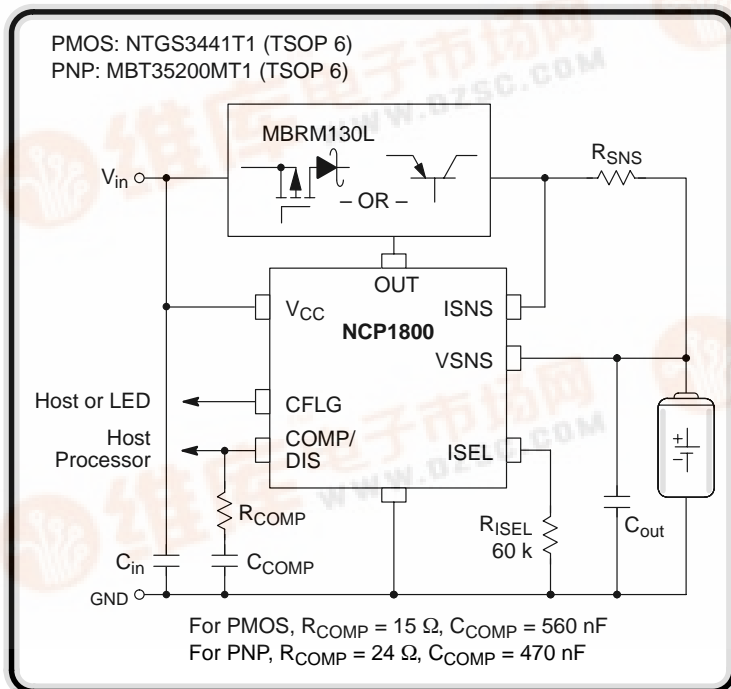

Figure 1. Typical Application

This device contains 1015 transistors.





# NCP1800

## MAXIMUM RATINGS

Rating	Symbol	Value	Unit
Supply Voltage	$V_{CC}$	16	V
Voltage Range for: VSNS Input ISNS Input COMP/DIS Input ISEL Input CFLG Output Out Output	–	–0.3 to 6.0 –0.3 to 6.0 –0.3 to 6.0 –0.3 to 6.0 –0.3 to 6.0 –0.3 to $V_{CC}$	V
OUT Sink Current	$I_o$	20	mA
Thermal Resistance, Junction to Air	$R_{\theta JA}$	240	°C/W
Operating Ambient Temperature	$T_A$	–20 to +85	°C
Operating Junction Temperature	$T_J$	–20 to +150	°C
Storage Temperature	$T_{stg}$	–55 to +150	°C

- This device series contains ESD protection and exceeds the following tests:  
Human Body Model (HBM)  $\leq 2.0$  kV per JEDEC standard: JESD22–A114.  
Machine Model (MM)  $\leq 200$  V per JEDEC standard: JESD22–A115.
- Latch-up Current Maximum Rating:  $\leq 150$  mA per JEDEC standard: JESD78.

## ELECTRICAL CHARACTERISTICS ( $T_A = 25^\circ\text{C}$ for typical values, $-20^\circ\text{C} < T_A < 85^\circ\text{C}$ for min/max values, unless otherwise noted.)

Characteristic	Symbol	Min	Typ	Max	Unit
Input Supply Voltage (Note 3)	$V_{CC}$	2.5	–	16	V
Input Supply Current	$I_{CC}$	–	140	250	$\mu\text{A}$
Regulated Output Voltage	NCP1800DM41 NCP1800DM42 $V_{REG}$	4.059 4.158	4.1 4.2	4.141 4.242	V
Full-Charge Current Reference Voltage $V_{CC} = 6.0$ V, $3.0$ V $< V_{SNS} < 4.2$ V, $R_{ISEL} = 60$ K $\Omega$ , $T_A = 25^\circ\text{C}$	$V_{FCHG}$	220	240	260	mV
Full-Charge Current Reference Voltage Temperature Coefficient $V_{CC} = 6.0$ V, $3.0$ V $< V_{SNS} < 4.2$ V, $R_{ISEL} = 60$ K $\Omega$	$TCV_{FCHG}$	–	–0.163	–	%/°C
Pre-Charge Current Reference Voltage $V_{CC} = 6.0$ V, $V_{SNS} < 3.0$ V, $R_{ISEL} = 60$ K $\Omega$ , $T_A = 25^\circ\text{C}$	$V_{PCHG}$	13.2	24	34.8	mV
Pre-Charge Current Reference Voltage Temperature Coefficient $V_{CC} = 6.0$ V, $V_{SNS} < 3.0$ V, $R_{ISEL} = 60$ K $\Omega$	$TCV_{PCHG}$	–	–0.180	–	%/°C
Pre-Charge Threshold Voltage	NCP1800DM41 NCP1800DM42 $V_{PCTH}$	2.78 2.85	2.93 3.0	3.08 3.15	V
$V_{CC}$ Under Voltage Lockout Voltage	$V_{UVLO}$	3.43	3.56	3.69	V
Hysteresis of $V_{CC}$ Under Voltage Lockout ( $V_{UVLO}$ ), $T_A = 25^\circ\text{C}$	–	90	150	195	mV
Hysteresis of $V_{CC}$ Under Voltage Lockout Voltage ( $V_{UVLO}$ ) Temperature Coefficient	–	–	0.261	–	%/°C
End-of-Charge Voltage Reference $V_{CC} = 6.0$ V, $V_{SNS} > 4.2$ V, $R_{ISEL} = 60$ K $\Omega$	$V_{EOC}$	20	24	28	mV
End-of-Charge Voltage Reference Temperature Coefficient $V_{CC} = 6.0$ V, $V_{SNS} > 4.2$ V, $R_{ISEL} = 60$ K $\Omega$	$TCV_{EOC}$	–	–0.160	–	%/°C
Charge Disable Threshold Voltage ( $I_{COMP} = 100$ $\mu\text{A}$ min.)	$V_{CDIS}$	–	–	0.08	V
$V_{CC}$ Over Voltage Lockout	$V_{OVLO}$	6.95	7.20	7.45	V
Hysteresis of $V_{CC}$ Over Voltage Lockout ( $V_{OVLO}$ ), $T_A = 25^\circ\text{C}$	–	90	150	180	mV
Hysteresis of $V_{CC}$ Over Voltage Lockout ( $V_{OVLO}$ ) Temperature Coefficient	–	–	0.39	–	%/°C
$V_{SNS}$ Over Voltage Lockout	NCP1800DM41 NCP1800DM42 $V_{SOVLO}$	4.3 4.4	4.4 4.5	4.5 4.6	V

- See the “External Adaptor Power Supply Voltage Selection” section of the application note to determine the minimum voltage of the charger power supplies.

# NCP1800

## ELECTRICAL CHARACTERISTICS (continued)

( $T_A = 25^\circ\text{C}$  for typical values,  $-20^\circ\text{C} < T_A < 85^\circ\text{C}$  for min/max values, unless otherwise noted.)

Characteristic	Symbol	Min	Typ	Max	Unit
Hysteresis of $V_{\text{SNS}}$ Over Voltage Lockout ( $V_{\text{SOVLO}}$ ), $T_A = 25^\circ\text{C}$	–	40	70	100	mV
Hysteresis of $V_{\text{SNS}}$ Over Voltage Lockout ( $V_{\text{SOVLO}}$ ) Temperature Coefficient $T_A = 25^\circ\text{C}$	–	–	0.52	–	%/ $^\circ\text{C}$
Full Charge Current Range with $R_{\text{SNS}} = 0.4 \Omega$	$I_{\text{REG1}}$	600	–	1000	mA
Full Charge Current Range with $R_{\text{SNS}} = 0.8 \Omega$	$I_{\text{REG2}}$	300	–	600	mA
Battery Drain Current ( $V_{\text{SNS}} + I_{\text{SNS}}$ ) $V_{\text{CC}} = \text{Ground}$ , $V_{\text{SNS}} = 4.2 \text{ V}$	$I_{\text{BDRN}}$	–	–	0.5	$\mu\text{A}$
CFLG Pin Output Low Voltage (CFLG = LOW, $I_{\text{CFLG}} = 5.0 \text{ mA}$ )	$V_{\text{CFLGL}}$	–	–	0.35	V
CFLG Pin Leakage Current (CFLG = HIGH)	$I_{\text{CFLGH}}$	–	–	0.1	$\mu\text{A}$

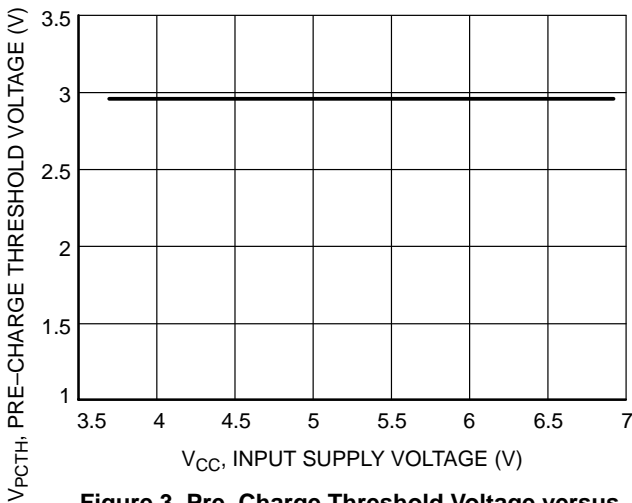

Figure 3. Pre-Charge Threshold Voltage versus Input Supply Voltage

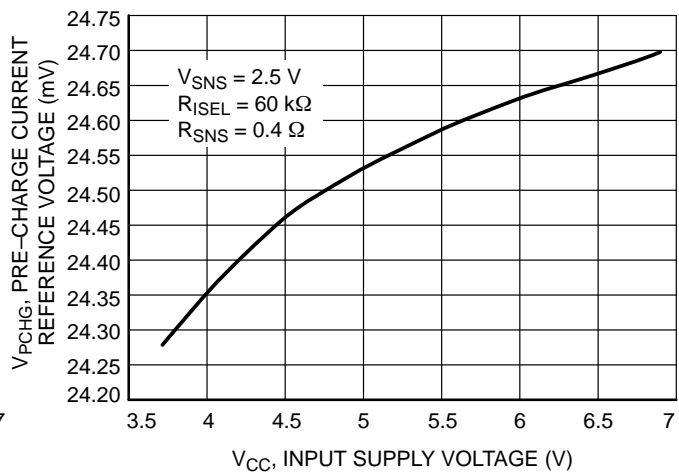

Figure 4. Pre-Charge Current Reference Voltage versus Input Supply Voltage

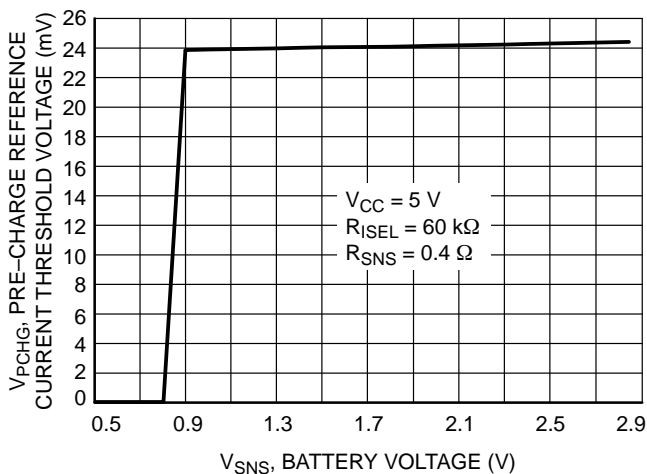

Figure 5. Pre-Charge Current Reference Voltage versus Battery Voltage

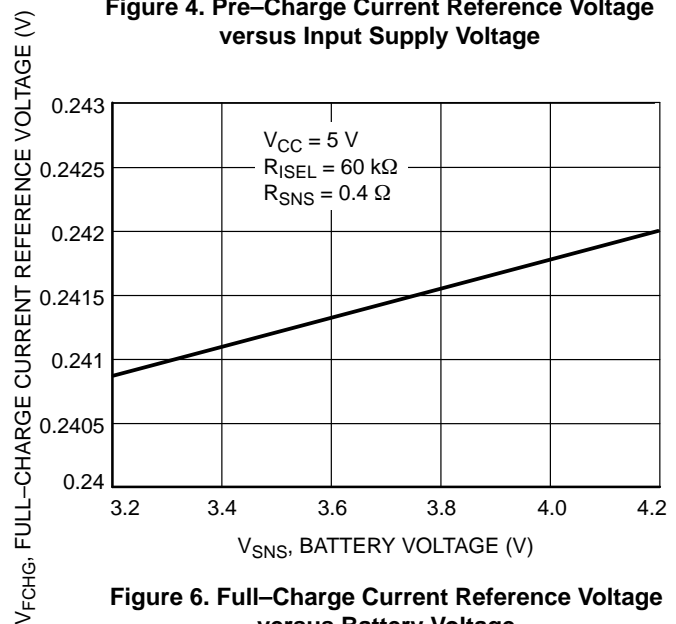
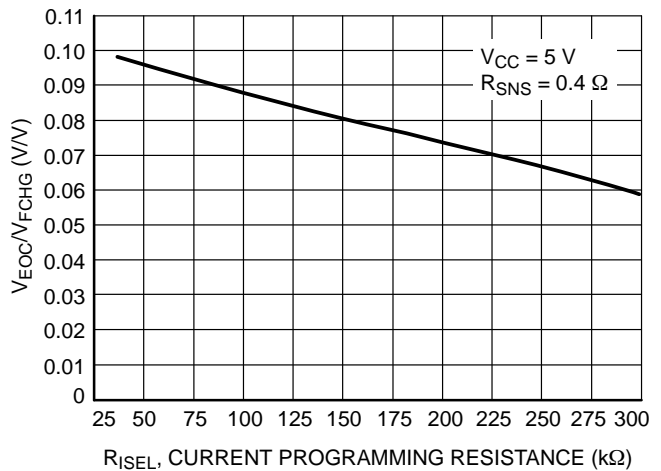
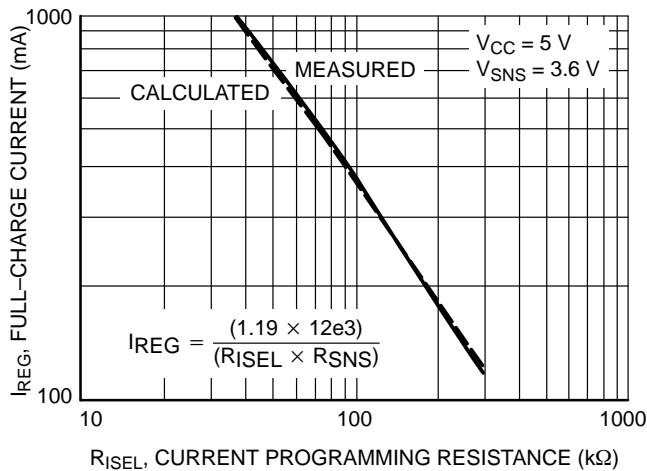
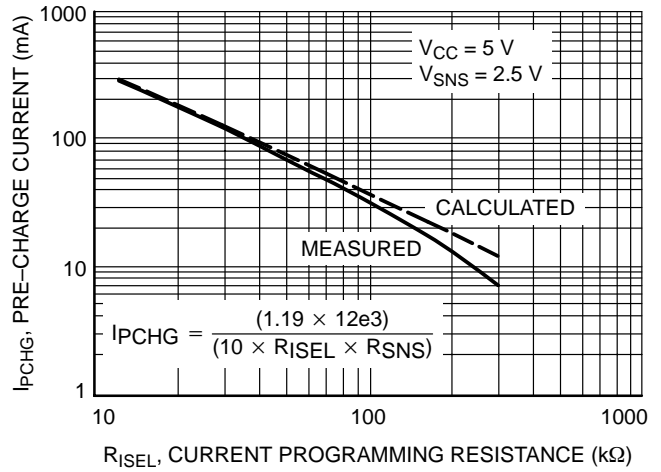
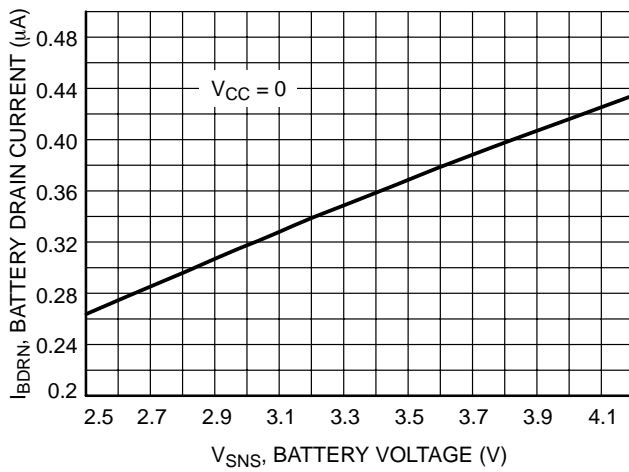
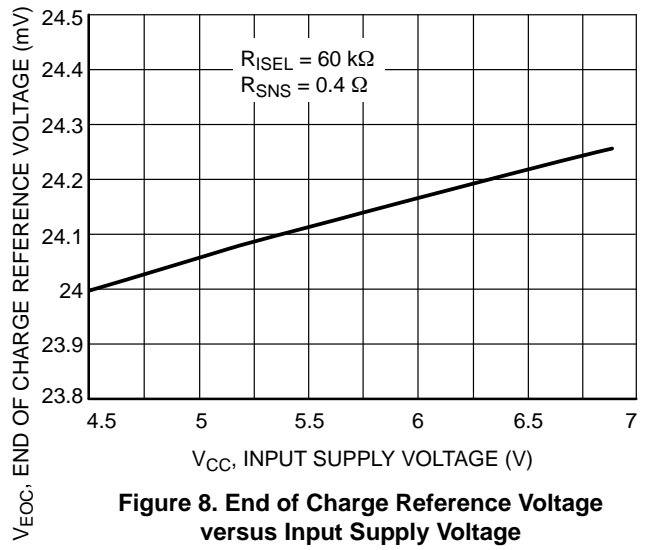
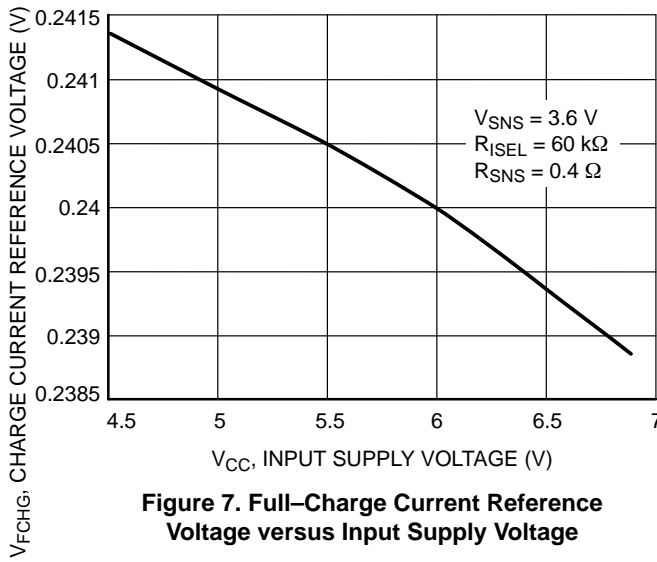
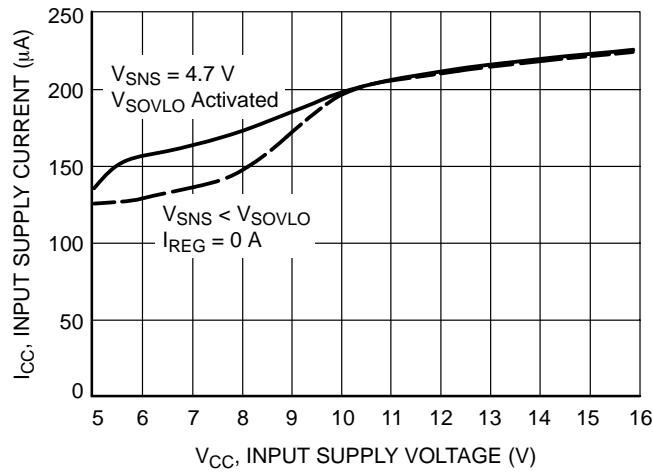

Figure 6. Full-Charge Current Reference Voltage versus Battery Voltage

# NCP1800



# NCP1800



**Figure 13. Input Supply Current versus Input Supply Voltage**

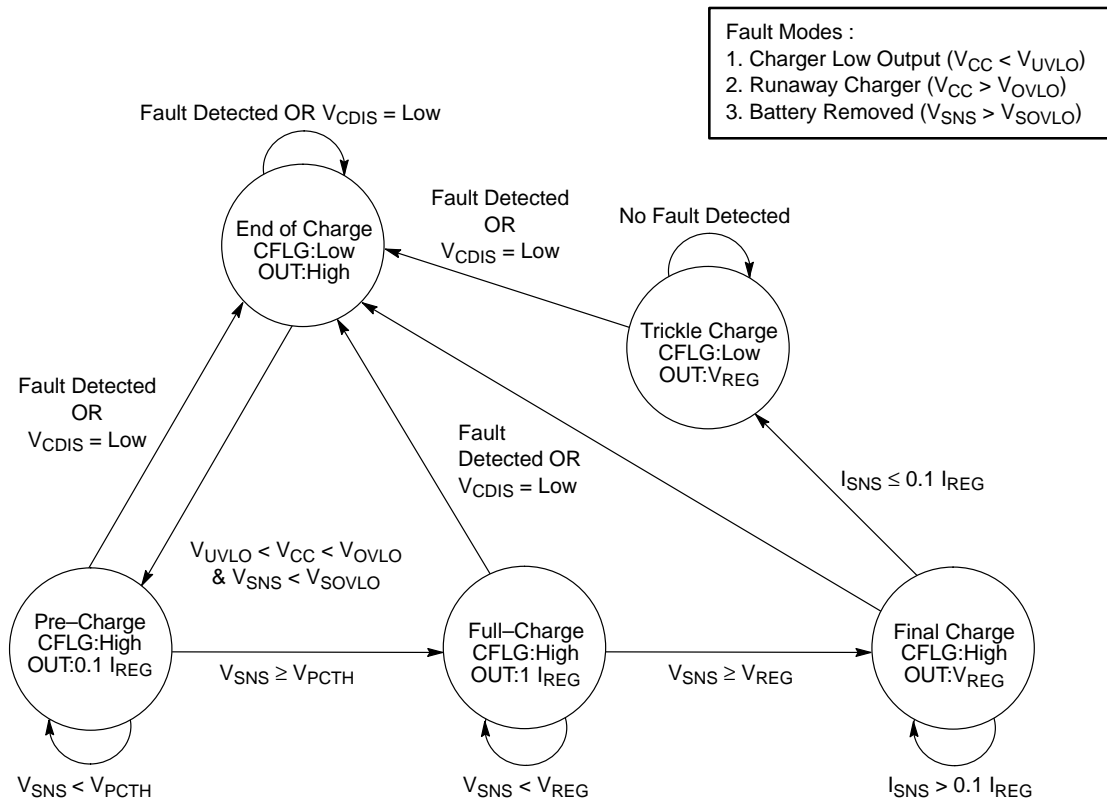

**Figure 14. NCP1800 State Machine Diagram**

# NCP1800

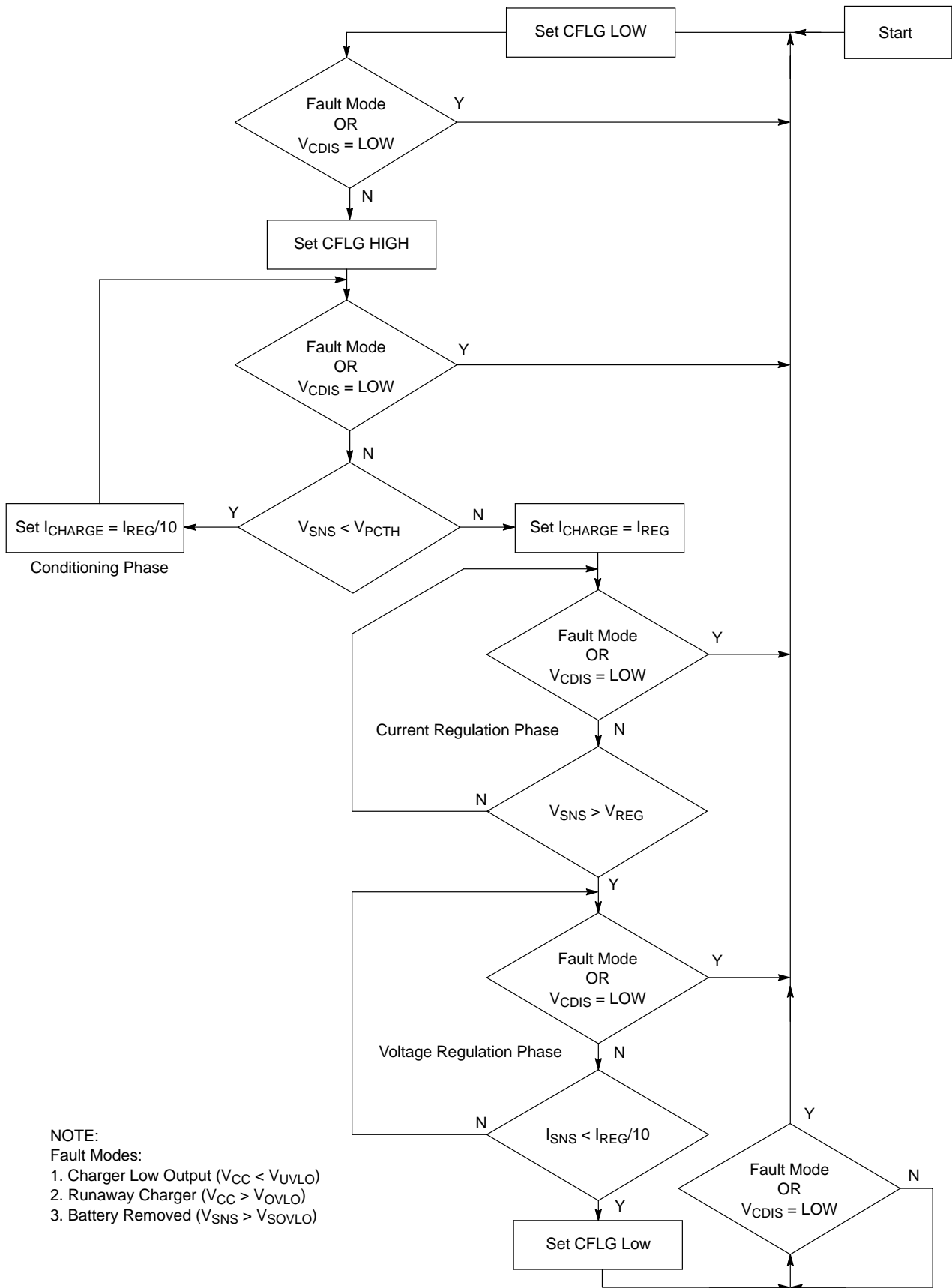

Figure 15. NCP1800 Charging Operational Flow Chart

# NCP1800

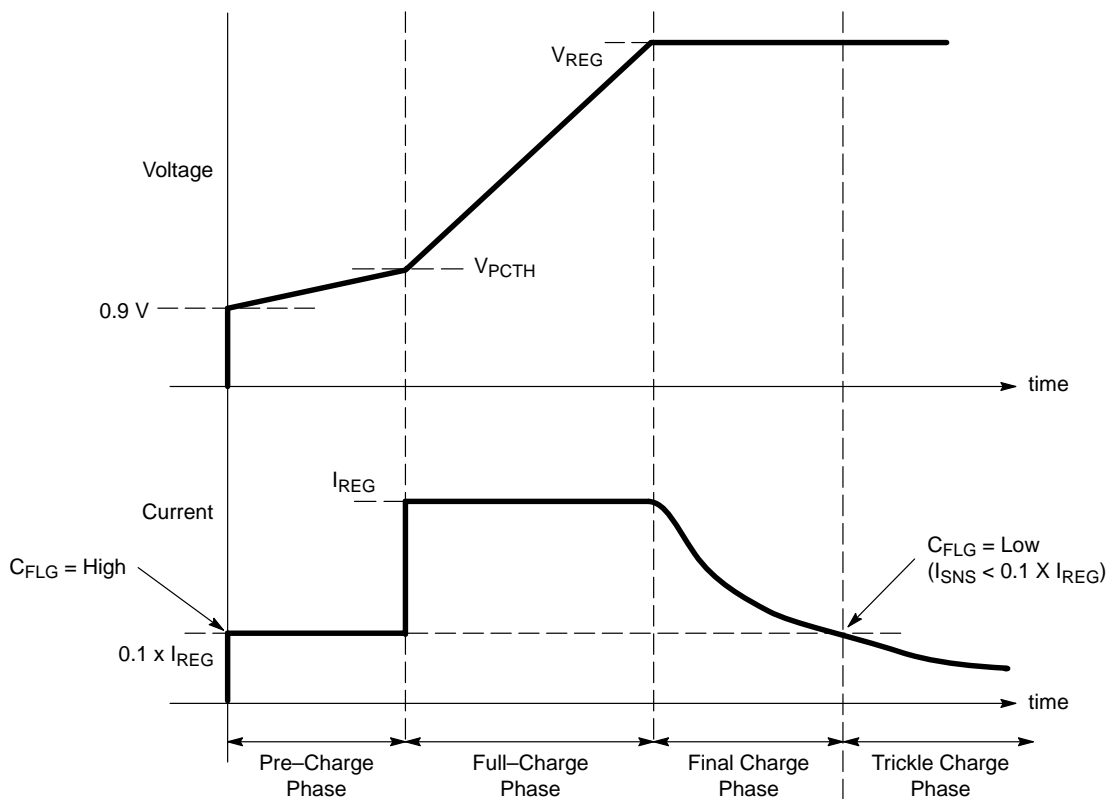

Figure 16. Typical Charging Algorithm

### Charge Status

Conditions	CFLG Pin
Pre-Charge, Full-Charge and Final Charge	High-Z
End-of-Charge, Trickle Charge and Faults	Low



# NCP1800

## Operation Descriptions

The NCP1800 is a linear lithium ion (Li-ion) battery charge controller and provides the necessary control functions for charging Li-ion batteries precisely and safely. It features the constant current and constant voltage method (CCCV) of charging.

### Conditioning and Pre-charge Phase

The NCP1800 initiates a charging cycle upon toggling the COMP/DIS to LOW or application of the valid external power source (i.e.  $V_{UVLO} < V_{CC} < V_{OVLO}$ ) with the Li-ion battery present or when the Li-ion battery is inserted. Before a charge cycle can begin, the battery conditions are verified to be within safe limits. The battery will not be charged when its voltage is less than 0.9 V or higher than  $V_{SOVLO}$ .

Li-ion batteries can be easily damaged when fast charged from a completely discharged state. Also, a fully discharged Li-ion battery may indicate an abnormal battery condition. With the built-in safety features of the NCP1800, the Li-ion battery pre-charges (Pre-Charge Phase) at 10% of the full rated charging current ( $I_{REG}$ ) when the battery voltage is lower than  $V_{PCTH}$  and the CFLG pin is HIGH. Typically, the battery voltage reaches  $V_{PCTH}$  in a few minutes and then the Full Charge phase begins.

### Full Charge (Current Regulation) Phase

When the battery voltage reaches  $V_{PCTH}$ , the NCP1800 begins fast charging the battery with full rate charging current  $I_{REG}$ . The NCP1800 monitors the charging current at the  $I_{SNS}$  input pin by the voltage drop across a current sense resistor,  $R_{SNS}$ , and the charging current is maintained at  $I_{REG}$  by the pass transistor throughout the full charge phase.

$I_{REG}$  is determined by  $R_{SNS}$  and  $R_{ISEL}$  with the following formula:

$$I_{REG} = \frac{(1.19 \times 12 \text{ k})}{(R_{ISEL} \times R_{SNS})}$$

And with  $R_{ISEL} = 60 \text{ k}$  and  $R_{SNS} = 0.4 \Omega$ ,  $I_{REG} = 0.6 \text{ A}$ .

Since the external P channel MOSFET or PNP transistor is used to regulate the current to charge the battery and operates in linear mode as a linear regulator, power is dissipated in the pass transistor. Designing with a very well regulated external adaptor (e.g. 5.1 V  $\pm 1\%$ ) can help to minimize the heat dissipation in the pass transistor. Care must be taken in heat sink designing in enclosed environments such as inside the battery operated portables or cellular phones.

The Full Charge phase continues until the battery voltage reaches  $V_{REG}$ . The NCP1800 comes in two options with  $V_{REG}$  thresholds of 4.1 and 4.2 V.

### Final Charge (Voltage Regulation) Phase

Once the battery voltage reaches  $V_{REG}$ , the pass transistor is controlled to regulate the voltage across the battery and the Final Charge phase (constant voltage across mode) begins. Once the charger is in the Final Charge phase, the charger maintains a regulated voltage and the charging current will begin to decrease and is dependent on the state of the charge of the battery. As the battery approaches a fully charged condition, the charge current falls to a very low value.

### Trickle Charge Phase

During the Final Charge phase, the charging current continues to decrease and the NCP1800 monitors the charging current through the current sense resistor  $R_{SNS}$ . When the charging current decreases to such a level that  $I_{SNS} < 0.1 \times I_{REG}$ , the CFLG pin is set to LOW and the Trickle Charge phase begins. The charger stays in the Trickle Charge phase until any fault modes are detected or the COMP/DIS pin is pulled low to start over the charging cycle.

## NCP1800

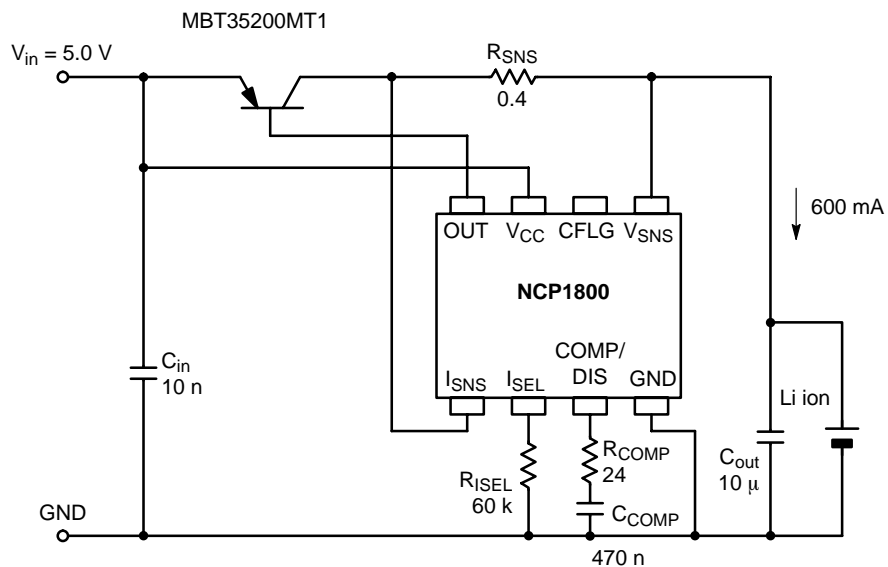

**Figure 17. Typical Application Circuit with PNP Transistor**

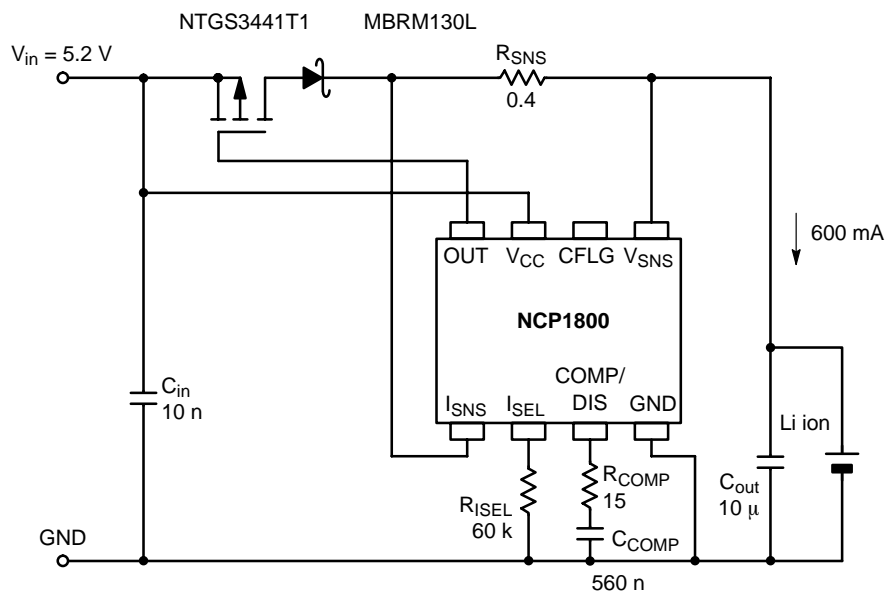

**Figure 18. Typical Application Circuit with P Channel MOSFET**

# NCP1800

## Selecting External Components

### External Adaptor Power Supply Voltage Selection

Since the NCP1800 is using a linear, charging algorithm, the efficiency is lower. Adapter voltage selection must be done carefully in order to minimize the heat dissipation. In general, the power supply input voltage should be around 5.0 to 6.0 V. The minimum input voltage should be chosen to minimize the heat dissipation in the system. Excessively high input voltages can cause too much heat dissipation and will complicate the thermal design in applications like cellular phones. With the overvoltage protection feature of the NCP1800, input voltages higher than 7.0 V will activate the overvoltage protection circuit and disconnect the power supply input to the battery and other circuitry.

For applications with the MBT35200,

$$\begin{aligned} V_{IN(min)} &> \text{Li-ion regulated voltage,} \\ &V_{REG} + \max V_{CE(sat)} + \text{voltage drop of } R_{SNS} \\ &> 4.2 \text{ V} + 0.15 \text{ V} + (0.6 \text{ A})(0.4 \Omega) \\ &= 4.59 \text{ V} \approx 4.6 \text{ V,} \\ &\text{(there is no blocking diode required with PNP)} \end{aligned}$$

For applications with the NTGS3441T1,

$$\begin{aligned} V_{IN(min)} &> \text{Li-ion regulated voltage,} \\ &V_{REG} + (0.6 \text{ A})(R_{DS(ON)}) \\ &+ V_F \text{ of Schottky Diode} + \text{voltage drop of } R_{SNS} \\ &> 4.2 \text{ V} + (0.6 \text{ A})(100 \text{ m}\Omega) + 0.38 \text{ V} \\ &+ (0.6 \text{ A})(0.4 \Omega) = 4.88 \text{ V} \approx 4.9 \text{ V} \end{aligned}$$

Therefore, with the PMOS application, if the output voltage accuracy is 5%, then a typ. 5.2 V  $\pm$ 5% output voltage adaptor must be used.

And for a very good regulated adaptor of accuracy 1%, 5.0 V  $\pm$ 1% output voltage adaptor can then be used. It is obvious that if tighter tolerance adaptors are used, heat dissipation can be minimized by using lower nominal voltage adaptors.

### Pass Element Selection

The pass element used with the NCP1800 can either be a PNP transistor or a P channel MOSFET. The type and size of the pass transistor is determined by input-output

differential voltage, charging current, current sense resistor and the type of blocking diode used.

The selected pass element must satisfy the following criteria:

Drop across pass element =

$$V_{IN(min)} - \text{Li-ion regulated voltage} - V_F - I_{REG} \times R_{SNS}$$

With:

$$\begin{aligned} V_{IN(min)} &= 5.0 \text{ V} \\ V_{REG} &= 4.2 \text{ V} \\ I_{REG} &= 0.6 \text{ A} \\ R_{SNS} &= 0.4 \Omega \end{aligned}$$

Dropout across pass element =

$$5.0 \text{ V} - 4.2 \text{ V} - 0.38 \text{ V} - (0.6 \text{ A})(0.4 \Omega) = 0.18 \text{ V}$$

When using p-channel MOSFET's, max.  $R_{DS(on)}$  should be less than  $(0.18 \text{ V})/(0.6 \text{ A}) = 0.3 \Omega$  at 0.6 A. And in PNP applications, as the blocking diode is not required, the blocking diode forward voltage drop must be neglected in the calculation.

### External Output Capacitor

Any good quality output filter can be used, independent of the capacitor's minimum ESR. However, a 10  $\mu$ F tantalum capacitor or electrolytic capacitor is recommended at the output to suppress fast ramping spikes at the  $V_{SNS}$  input and to ensure stability for 1.0 A at full range. The capacitor should be mounted with the shortest possible lead or track length to the  $V_{SNS}$  and GND pins.

### Current Sense Resistor

The charging current can be set by the value of the current sense resistor as in the previous formula. Proper de-rating is advised when selecting the power dissipation rating of the resistor. If necessary,  $R_{ISEL}$  can also be changed for proper selection of the  $R_{SNS}$  values. Take note of the recommended full-charge current ranges specified in the electrical characteristics section. Also notice the effect of  $R_{ISEL}$  on the accuracy of pre-charge current and end-of-charge detection as noted in Figures 10 and 12, respectively.

# NCP1800

## PACKAGE DIMENSIONS

Micro8  
DM SUFFIX  
CASE 846A-02  
ISSUE E

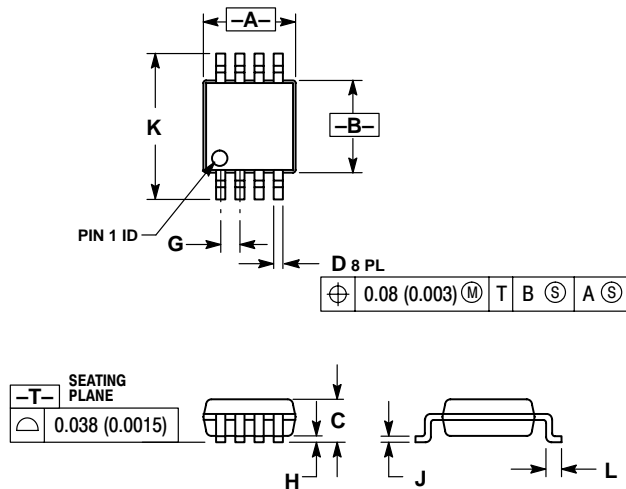

### NOTES:

1. DIMENSIONING AND TOLERANCING PER ANSI Y14.5M, 1982.
2. CONTROLLING DIMENSION: MILLIMETER.
3. DIMENSION A DOES NOT INCLUDE MOLD FLASH, PROTRUSIONS OR GATE BURRS. MOLD FLASH, PROTRUSIONS OR GATE BURRS SHALL NOT EXCEED 0.15 (0.006) PER SIDE.
4. DIMENSION B DOES NOT INCLUDE INTERLEAD FLASH OR PROTRUSION. INTERLEAD FLASH OR PROTRUSION SHALL NOT EXCEED 0.25 (0.010) PER SIDE.

DIM	MILLIMETERS		INCHES	
	MIN	MAX	MIN	MAX
A	2.90	3.10	0.114	0.122
B	2.90	3.10	0.114	0.122
C	---	1.10	---	0.043
D	0.25	0.40	0.010	0.016
G	0.65 BSC		0.026 BSC	
H	0.05	0.15	0.002	0.006
J	0.13	0.23	0.005	0.009
K	4.75	5.05	0.187	0.199
L	0.40	0.70	0.016	0.028

ON Semiconductor and  are trademarks of Semiconductor Components Industries, LLC (SCILLC). SCILLC reserves the right to make changes without further notice to any products herein. SCILLC makes no warranty, representation or guarantee regarding the suitability of its products for any particular purpose, nor does SCILLC assume any liability arising out of the application or use of any product or circuit, and specifically disclaims any and all liability, including without limitation special, consequential or incidental damages. "Typical" parameters which may be provided in SCILLC data sheets and/or specifications can and do vary in different applications and actual performance may vary over time. All operating parameters, including "Typicals" must be validated for each customer application by customer's technical experts. SCILLC does not convey any license under its patent rights nor the rights of others. SCILLC products are not designed, intended, or authorized for use as components in systems intended for surgical implant into the body, or other applications intended to support or sustain life, or for any other application in which the failure of the SCILLC product could create a situation where personal injury or death may occur. Should Buyer purchase or use SCILLC products for any such unintended or unauthorized application, Buyer shall indemnify and hold SCILLC and its officers, employees, subsidiaries, affiliates, and distributors harmless against all claims, costs, damages, and expenses, and reasonable attorney fees arising out of, directly or indirectly, any claim of personal injury or death associated with such unintended or unauthorized use, even if such claim alleges that SCILLC was negligent regarding the design or manufacture of the part. SCILLC is an Equal Opportunity/Affirmative Action Employer.

### PUBLICATION ORDERING INFORMATION

#### Literature Fulfillment:

Literature Distribution Center for ON Semiconductor  
P.O. Box 5163, Denver, Colorado 80217 USA  
Phone: 303-675-2175 or 800-344-3860 Toll Free USA/Canada  
Fax: 303-675-2176 or 800-344-3867 Toll Free USA/Canada  
Email: ONlit@hibbertco.com

N. American Technical Support: 800-282-9855 Toll Free USA/Canada

JAPAN: ON Semiconductor, Japan Customer Focus Center  
4-32-1 Nishi-Gotanda, Shinagawa-ku, Tokyo, Japan 141-0031  
Phone: 81-3-5740-2700  
Email: r14525@onsemi.com

ON Semiconductor Website: <http://onsemi.com>

For additional information, please contact your local Sales Representative.