



MOTOROLA

Dual Modulus Prescaler

The MC12019 is a divide by 20 and 21 dual modulus prescaler. It will divide by 20 when the modulus control input is HIGH and divide by 21 when the modulus control input is LOW.

- 225 MHz Toggle Frequency
- Low-Power 7.5 mA Maximum at 5.5 V
- Control Input is Compatible with Standard Motorola CMOS Synthesizers
- Emitter Follower Output

MC12019

MECL PLL COMPONENTS ÷20/21 DUAL MODULUS PRESCALER

SEMICONDUCTOR
TECHNICAL DATA



D SUFFIX
PLASTIC PACKAGE
CASE 751
(SO-8)

SIMPLIFIED BLOCK DIAGRAM

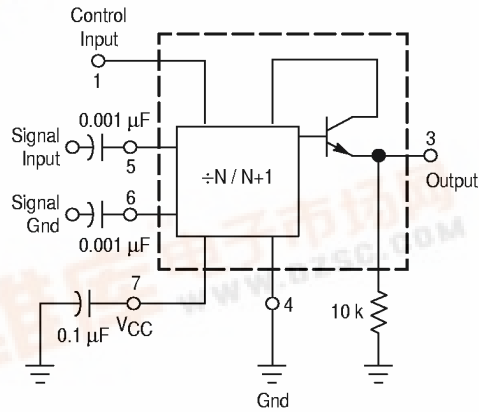

PIN CONNECTIONS

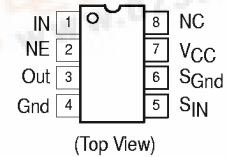

ORDERING INFORMATION

Device	Operating Temperature Range	Package
MC12019D	T _A = - 40 to 85°C	SO-8



MC12019

MAXIMUM RATINGS

Rating	Symbol	Value	Unit
Power Supply Voltage, Pin 7	V_{CC}	8.0	Vdc
Operating Temperature Range	T_A	-40 to +85	°C
Storage Temperature Range	T_{stg}	-65 to +175	°C

NOTE: ESD data available upon request.

ELECTRICAL CHARACTERISTICS ($V_{CC} = 4.5$ to 5.5 V; $T_A = -40$ to 85°C), unless otherwise noted.)

Characteristic	Symbol	Min	Typ	Max	Unit
Toggle Frequency (Sine Wave Input)	f_{max}	225	–	–	MHz
	f_{min}	–	–	20	
Supply Current	I_{CC}	–	–	7.5	mA
Control Input HIGH (± 20)	V_{IH}	2.0	–	–	V
Control Input LOW (± 21)	V_{IL}	–	–	0.8	V
Output Swing Voltage (10 k Ω to ground)	V_{out}	600	–	1200	mVpp
Input Voltage Sensitivity 20 MHz to 225 MHz	V_{in}	–	–	–	mVpp
		200	–	800	
PLL Response Time (Notes 1 and 2)	t_{PLL}	–	–	t_{out-70}	ns

NOTES: 1. t_{PLL} = the period of time the PLL has from the prescaler rising output transition (50%) to the modulus control input edge transition (50%) to ensure proper modulus selection.

2. t_{out} = period of output waveform.

MC12019

OUTLINE DIMENSIONS

D SUFFIX
PLASTIC PACKAGE
CASE 751-06
(SO-8)
ISSUE T

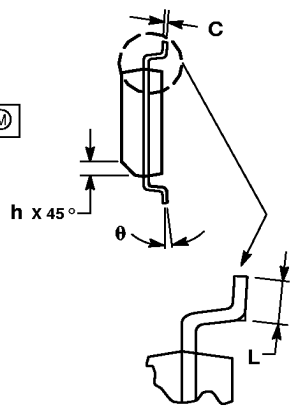
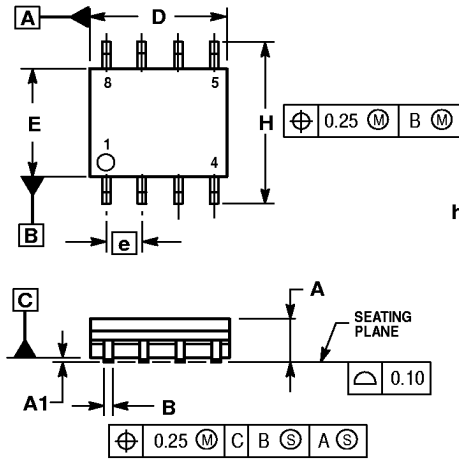

- NOTES:
1. DIMENSIONING AND TOLERANCING PER ASME Y14.5M, 1994.
 2. DIMENSIONS ARE IN MILLIMETER.
 3. DIMENSION D AND E DO NOT INCLUDE MOLD PROTRUSION.
 4. MAXIMUM MOLD PROTRUSION 0.15 PER SIDE.
 5. DIMENSION B DOES NOT INCLUDE DAMBAR PROTRUSION. ALLOWABLE DAMBAR PROTRUSION SHALL BE 0.127 TOTAL IN EXCESS OF THE B DIMENSION AT MAXIMUM MATERIAL CONDITION.

DIM	MILLIMETERS	
	MIN	MAX
A	1.35	1.75
A1	0.10	0.25
B	0.35	0.49
C	0.19	0.25
D	4.80	5.00
E	3.80	4.00
e	1.27 BSC	
H	5.80	6.20
h	0.25	0.50
L	0.40	1.25
θ	0°	7°