

6249827 0014972 5T1 MIT3
 查询M54519P 供应商
 MITSUBISHI (DGT L LOGIC)

MITSUBISHI BIPOLAR DIGITAL ICs
 捷多邦, 专业PCB打样工厂 24小时加
 急出货
M54519P

7-UNIT 400mA DARLINGTON TRANSISTOR ARRAY

DESCRIPTION

The M54519P, 7-channel sink driver, consists of 14 NPN transistors connected to form seven high current gain driver pairs.

FEATURES

- High output sustaining voltage to 40V
- High output sink current to 400mA
- PMOS Compatible input
- Wide operating temperature range ($T_a = -20 \sim +75^\circ\text{C}$)

APPLICATION

Relay and printer driver, LED or incandescent display digit driver, Interfacing for standard MOS/BIPOLAR logics

FUNCTION

The M54519P is comprised of seven NPN darlington driver pairs with $20\text{k}\Omega$ series input resistors.

All emitters and the substrate are connected together to pin 8. The output are capable of sinking 400mA and will withstand 40V in the OFF state.

PIN CONFIGURATION (TOP VIEW)

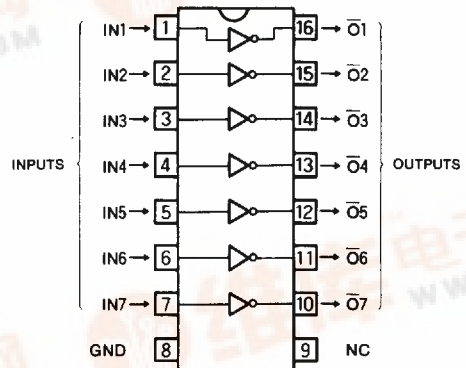

Outline 16P4

NC : No connection

CIRCUIT SCHEMATIC

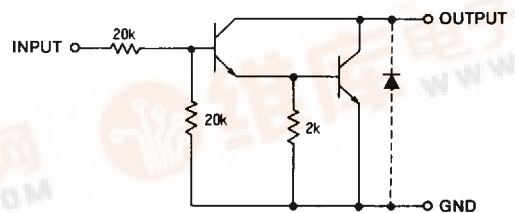

The diodes shown by broken line are parasite diodes and must not be used

Unit : Ω

ABSOLUTE MAXIMUM RATINGS ($T_a = -20 \sim +75^\circ\text{C}$, unless otherwise noted)

Symbol	Parameter	Conditions	Ratings	Unit
V_{CEO}	Output sustaining voltage	Transistor OFF	$-0.5 \sim +40$	V
I_C	Collector current per channel	Transistor ON	400	mA
V_I	Input voltage		$-0.5 \sim +40$	V
P_d	Power dissipation	$T_a = 25^\circ\text{C}$	1.47	W
T_{opr}	Operating temperature		$-20 \sim +75$	$^\circ\text{C}$
T_{stg}	Storage temperature		$-55 \sim +125$	$^\circ\text{C}$



7-UNIT 400mA DARLINGTON TRANSISTOR ARRAY

RECOMMENDED OPERATIONAL CONDITIONS ($T_a = -20 \sim +75^\circ\text{C}$, unless otherwise noted)

Symbol	Parameter *		Limits			Unit
			Min	Typ	Max	
V_O	Output voltage		0		40	V
I_C	Collector current per channel	Percent duty cycle less than 8%	0		400	mA
		Percent duty cycle less than 30%	0		200	
V_{IH}	"H" Input voltage	$I_C = 400\text{mA}$	8		30	V
		$I_C = 100\text{mA}$	5		30	
V_{IL}	"L" Input voltage	$I_{O(leak)} = 50\mu\text{A}$	0		0.5	V

ELECTRICAL CHARACTERISTICS ($T_a = -20 \sim +75^\circ\text{C}$, unless otherwise noted)

Symbol	Parameter	Test conditions	Limits			Unit
			Min	Typ*	Max	
$V_{(BR)CEO}$	Output sustaining voltage	$I_{CEO} = 100\mu\text{A}$	40			V
$V_{CE(sat)}$	Output saturation voltage	$V_I = 8\text{V}, I_C = 400\text{mA}$		1.2	2.4	V
		$V_I = 5\text{V}, I_C = 200\text{mA}$		0.9	1.6	
I_I	Input current	$V_I = 17\text{V}$	0.3	0.8	1.8	mA
h_{FE}	DC forward current gain	$V_{CE} = 4\text{V}, I_C = 400\text{mA}, T_a = 25^\circ\text{C}$	1000	6000		—

* : Typical values are at $T_a = 25^\circ\text{C}$.

TYPICAL CHARACTERISTICS

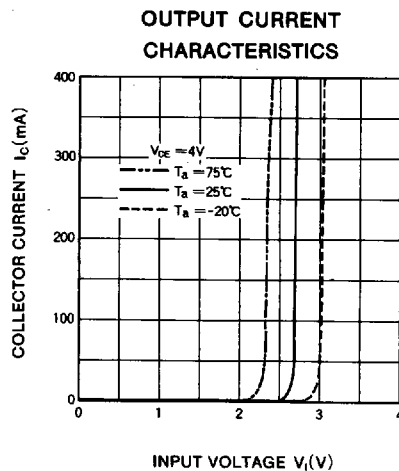
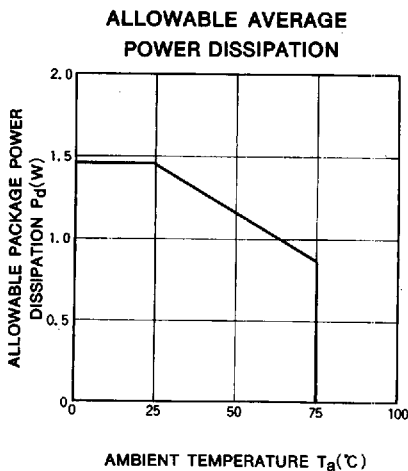

7-UNIT 400mA DARLINGTON TRANSISTOR ARRAY

ALLOWABLE COLLECTOR CURRENT AS A FUNCTION OF DUTY CYCLE

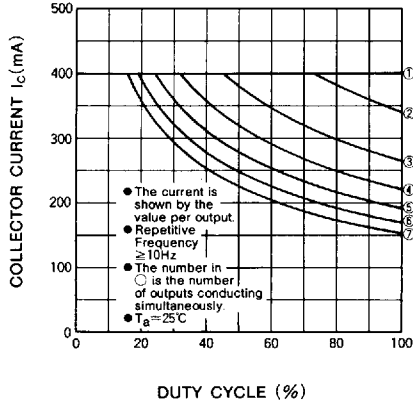

ALLOWABLE COLLECTOR CURRENT AS A FUNCTION OF DUTY CYCLE

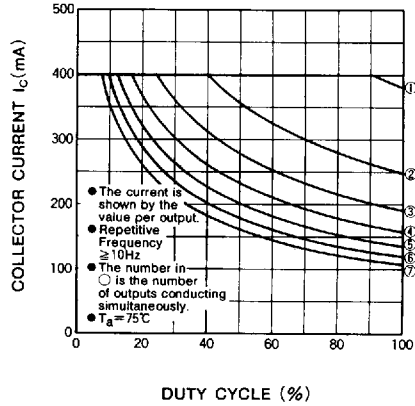

DC CURRENT GAIN CHARACTERISTICS

