

STR-S6707 THRU STR-S6709

Data Sheet
281334

OFF-LINE SWITCHING REGULATORS - WITH BIPOLAR SWITCHING TRANSISTOR

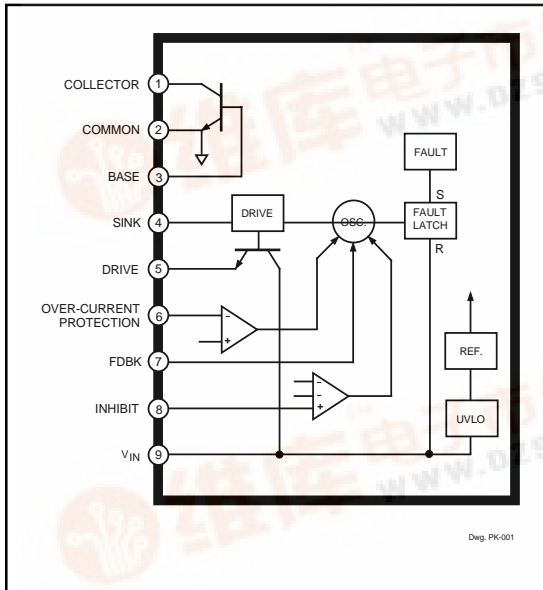

ABSOLUTE MAXIMUM RATINGS

Supply Voltage, V_{IN}	15 V
Output Voltage, V_{CEX}	850 V
V_{EBO}	7 V
Continuous Output Current, I_C	See Table
1 ms Single-Pulse Output Current, I_{CM}	See Table
Sink Current, I_S	See Table
Drive Current, I_D	-700 mA
Feedback Current, I_{FDBK}	20 mA
Inhibit Voltage, V_{INH}	15 V
Over-Current Protection Voltage Range, V_{OCP}	± 3.5 V
Insulation Voltage, $V_{WM(RMS)}$	2000 V
Package Power Diss., P_D	See Graph
Output Junction Temperature, T_J ..	+150°C
Internal Frame Temperature, T_F ...	+125°C
Operating Temperature Range, T_A	-20°C to +125°C
Storage Temperature Range, T_{STG}	-40°C to +125°C

The STR-S6707, STR-S6708, and STR-S6709 are specifically designed to meet the requirement for increased integration and reliability in off-line quasi-resonant flyback converters. These devices incorporate the primary control and proportional drive circuit with a third-generation high-voltage bipolar switching transistor.

Crucial system parameters such as maximum ON time and OFF time are fixed during manufacture. Local control circuit decoupling and layout are optimized within each device.

Cycle-by-cycle current limiting, under-voltage lock-out with hysteresis, over-voltage protection, and thermal shutdown protect these devices during all normal and overload conditions. Over-voltage protection and thermal shutdown are latched after a short delay. A versatile triple-level inhibit circuit includes the OFF time synchronization required to establish quasi-resonant operation. The inhibit function has also been expanded to initiate operation in stand-by mode in which the power supply delivers a small fraction of the steady-state output power. The dual requirements of dielectric isolation and low transient thermal impedance and steady-state thermal resistance are satisfied in an over-molded single-in-line power package.

Proven in substantial volumes, these devices and their fixed-frequency counterparts represent a significant advance in off-line SMPS reliability growth and integration.

FEATURES

- Quasi-Resonant Operation for Low EMI and High Efficiency
- Output Power to 220 W
- Low-Power Output Standby Mode
- Pulse-by-Pulse Over-Current Protection
- Latched Over-Voltage and Thermal Protection
- Third-Generation Switching Transistor with Proportional Drive
- Maximum ON Time and Off Time Set During Manufacture
- Internal Under-Voltage Lockout with Hysteresis
- Over-Molded SIP with Integral Isolated Heat Spreader

Always order by complete part number:

Part Number	Max. Cont. Current, I_C	Peak Current, I_{CM}	Max. Sink Current, I_S
STR-S6707	6 A	12 A	1.5 A
STR-S6708	7.5 A	15 A	1.5 A
STR-S6709	10 A	20 A	2 A

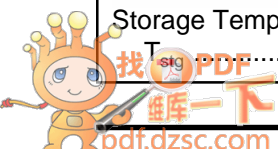

STR-S6707 THRU STR-S6709 OFF-LINE QUASI-RESONANT FLYBACK SWITCHING REGULATORS

STR-S6707 AND STR-S6708 FUNCTIONAL BLOCK DIAGRAM

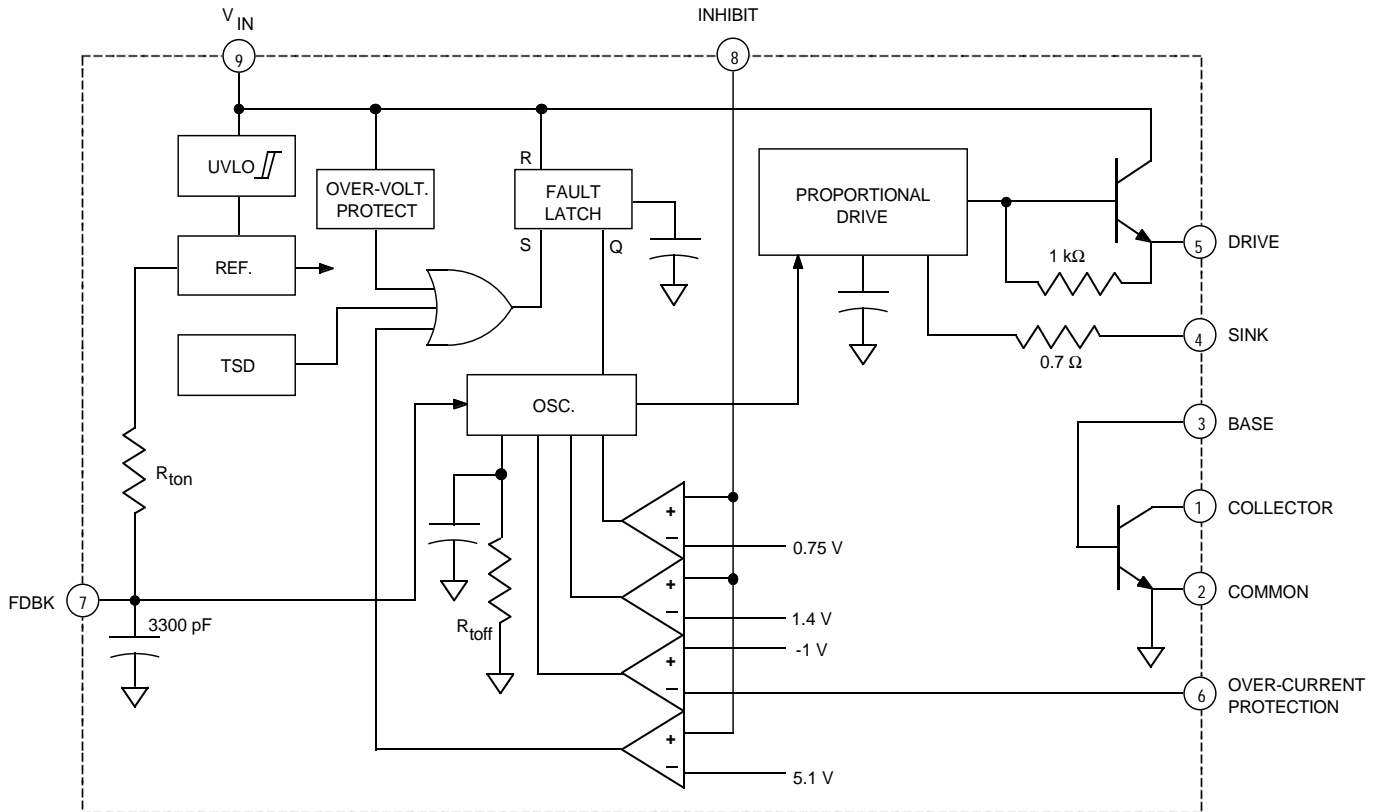

Dwg. FK-001

ALLOWABLE PACKAGE POWER DISSIPATION

MAXIMUM SAFE OPERATING AREA

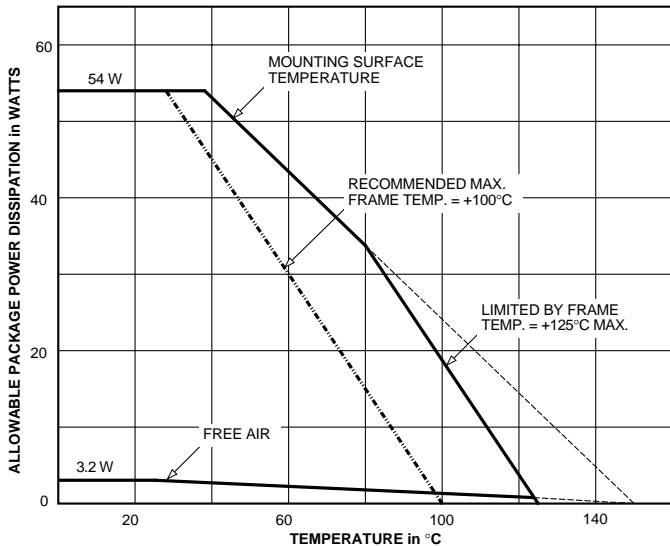

Dwg. GK-003-2

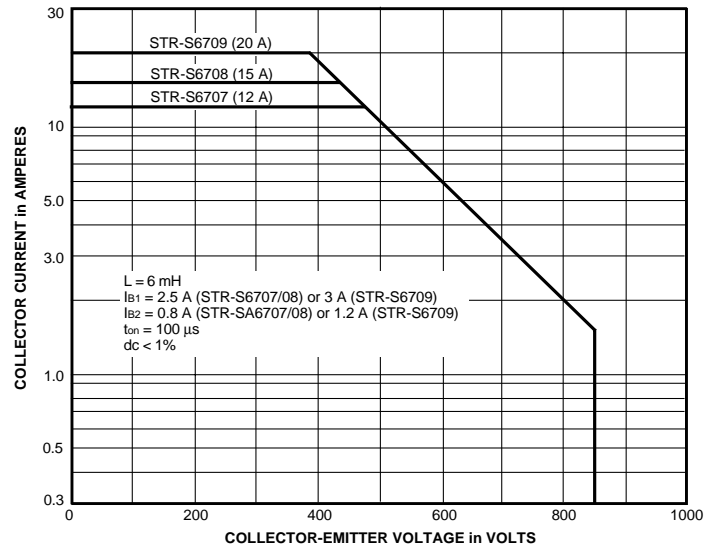

Dwg. GK-002

STR-S6707 THRU STR-S6709 OFF-LINE QUASI-RESONANT FLYBACK SWITCHING REGULATORS

**STR-S6709
FUNCTIONAL BLOCK DIAGRAM
AS ABOVE
EXCEPT FOR SINK OUTPUT**

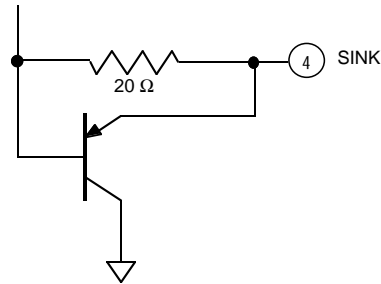

ELECTRICAL CHARACTERISTICS at $T_A = +25^\circ\text{C}$, $V_{IN} = 8.5\text{ V}$, voltage measurements are referenced to Common (pin 2) (unless otherwise noted).

Characteristic	Symbol	Test Conditions	Limits			
			Min.	Typ.	Max.	Units
On-State Voltage	V_{INT}	Turn-on, increasing V_{IN}	7.6	8.0	8.4	V
Under-Voltage Lockout	V_{INQ}	Turn-off, decreasing V_{IN}	4.6	4.9	5.2	V
Over-Voltage Threshold	$V_{OVP(th)}$		9.2	∅	10.7	V
Output Leakage Current	I_{CEX}	$V_{CE} = 850\text{ V}$, $V_{BE} = -1.5\text{ V}$	∅	∅	100	μA
Output Saturation Voltage	$V_{CE(sat)}$	STR-S6707, $I_C = 2\text{ A}$, $I_B = 400\text{ mA}$	∅	∅	400	mV
		STR-S6708, $I_C = 3\text{ A}$, $I_B = 600\text{ mA}$	∅	∅	400	mV
		STR-S6709, $I_C = 4\text{ A}$, $I_B = 800\text{ mA}$	∅	∅	400	mV
	$V_{BE(sat)}$	STR-S6707, $I_C = 2\text{ A}$, $I_B = 400\text{ mA}$	∅	∅	1.5	V
		STR-S6708, $I_C = 3\text{ A}$, $I_B = 600\text{ mA}$	∅	∅	1.5	V
		STR-S6709, $I_C = 4\text{ A}$, $I_B = 800\text{ mA}$	∅	∅	1.5	V
DC Current Gain	h_{FE}	$V_{CE} = 4\text{ V}$, $I_C = 1\text{ A}$	29	∅	61	∅
Maximum ON Time	t_{on}		33	∅	41	μs
Minimum OFF Time	t_{off}		45	∅	55	μs
Over-Current Threshold	$V_{OCP(th)}$		-0.9	-1.0	-1.1	V
Feedback Threshold Volt.	$V_{FDBK(th)}$		∅	650	∅	mV
Inhibit Threshold Voltage	$V_{INH(th)}$	Oscillation stops	0.65	0.75	0.85	V
		Oscillation synchronized	∅	1.4	2.0	V
		Oscillation stops (fault latch set)	3.2	5.1	5.6	V
Latch Holding Current	I_{INH}	V_{IN} reduced from 10.7 V to 4 V	∅	∅	500	μA
Latch Reset Voltage	V_Q	$I_{IN} \leq 100\text{ μA}$, V_{IN} reduced from 10.7 V	2.5	3.1	∅	V
Supply Current	$I_{IN(ON)}$	Operating	15	∅	29	mA
	$I_{IN(OFF)}$		∅	∅	200	μA
Insulation RMS Voltage	$V_{WM(RMS)}$	All terminals simultaneous reference metal plate against backside	2000	∅	∅	V
Thermal Shutdown	T_J		125	150	∅	°C
Thermal Resistance	$R_{\theta JM}$	Output junction to mounting surface	∅	2.0	∅	°C/W

NOTES: Negative current is defined as coming out of (sourcing) the specified device terminal.
Typical Data is for design information only.

STR-S6707 THRU STR-S6709
OFF-LINE
QUASI-RESONANT FLYBACK
SWITCHING REGULATORS

TYPICAL CHARACTERISTICS

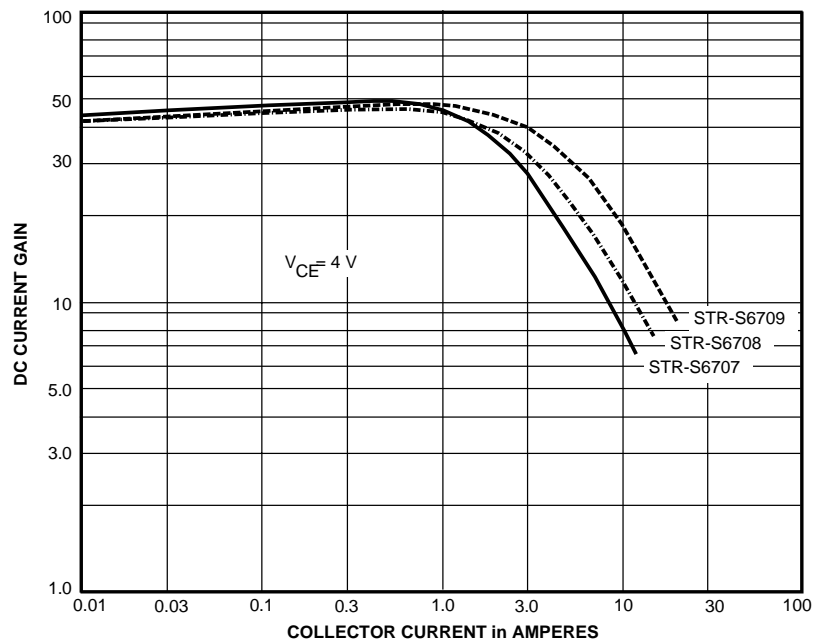

Dwg. GK-001

STR-S6707 THRU STR-S6709 OFF-LINE QUASI-RESONANT FLYBACK SWITCHING REGULATORS

TYPICAL QUASI-RESONANT FLYBACK CONVERTER

WARNING: lethal potentials are present. See text.

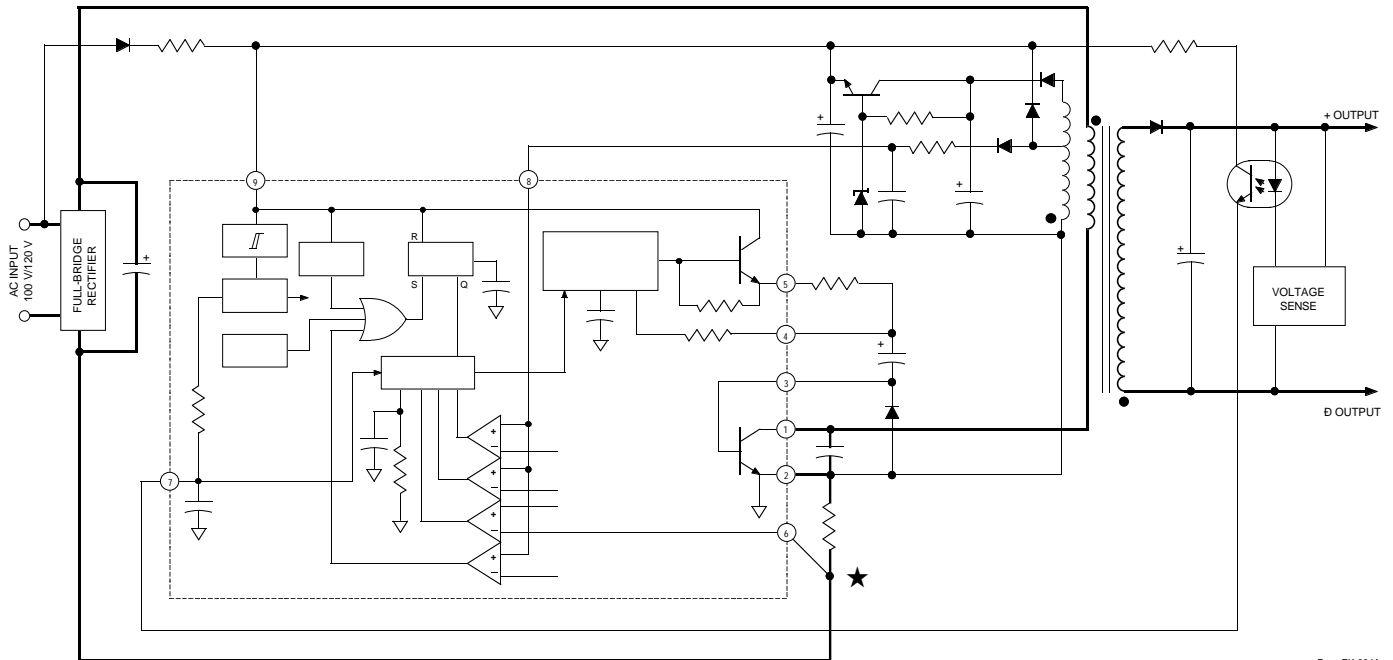

Dwg. EK-004A

APPLICATIONS INFORMATION

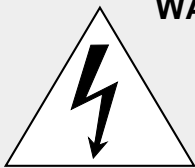

WARNING ⚡ These devices are designed to be operated at lethal voltages and energy levels. Circuit designs that embody these components must conform with applicable safety requirements. Precautions must be taken to prevent accidental contact with power-line potentials. Do not connect grounded test equipment.

The use of an isolation transformer is recommended during circuit development and breadboarding.

Recommended mounting hardware torque:

4.34 \pm 5.79 lbf \cdot ft (6 \pm 8 kg \cdot cm or 0.588 \pm 0.784 Nm).

Recommended metal-oxide-filled, alkyl-degenerated oil base, silicone grease:

Dow Corning 340, or equivalent

STR-S6707 THRU STR-S6709
OFF-LINE
QUASI-RESONANT FLYBACK
SWITCHING REGULATORS

Dimensions in Inches
 (for reference only)

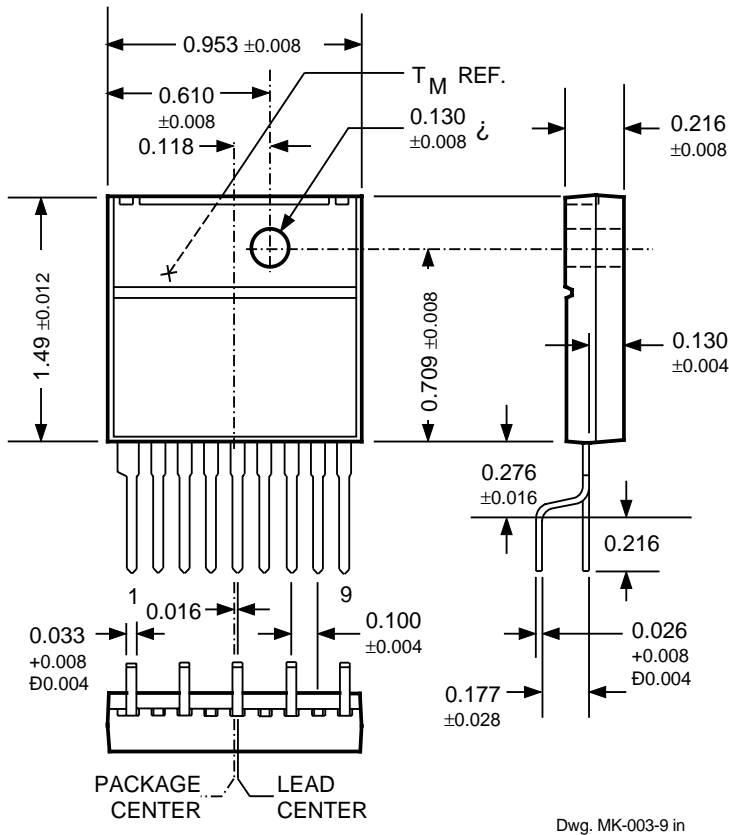

NOTE: Exact body and lead configuration at vendor's option within limits shown.

STR-S6707 THRU STR-S6709
OFF-LINE
QUASI-RESONANT FLYBACK
SWITCHING REGULATORS

Dimensions in Millimeters
 (controlling dimensions)

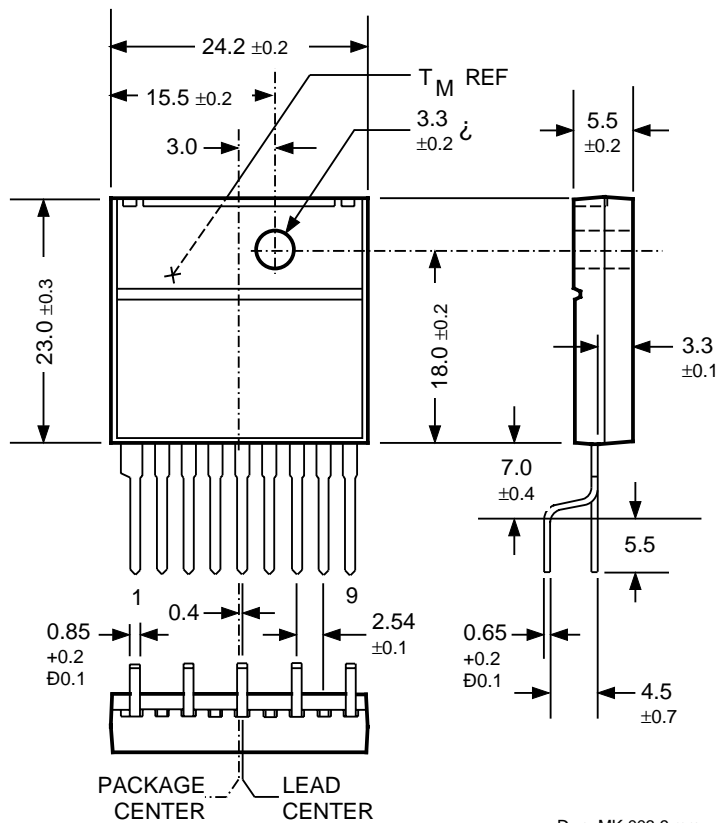

NOTE: Exact body and lead configuration at vendor's option within limits shown.

STR-S6707 THRU STR-S6709
OFF-LINE
QUASI-RESONANT FLYBACK
SWITCHING REGULATORS

The products described here are manufactured in Japan by Sanken Electric Co., Ltd. for sale by Allegro MicroSystems, Inc.

Sanken Electric Co., Ltd. and Allegro MicroSystems, Inc. reserve the right to make, from time to time, such departures from the detail specifications as may be required to permit improvements in the performance, reliability, or manufacturability of their products. Therefore, the user is cautioned to verify that the information in this publication is current before placing any order.

These products are not authorized for use as critical components in life-support appliances, devices, or systems without express written approval.

The information included herein is believed to be accurate and reliable. However, Sanken Electric Co., Ltd. and Allegro MicroSystems, Inc. assume no responsibility for its use; nor for any infringements of patents or other rights of third parties which may result from its use.