

Wideband RMS-DC Converter Building Block

FEATURES

- 300MHz 3dB Bandwidth
- 1% Accuracy DC-50MHz
- 2% to 100MHz
- Bandwidth Flat Over Input Voltage Range
- 50:1 Crest Factor
- 20:1 Dynamic Range
- 35V Peak Input
- Thermally Based Operation
- Fully Specified Thermal and Electrical Parameters
- Standard IC Packages
- Resistive Inputs

APPLICATIONS

- Wideband RMS Voltmeters
- RF Leveling Loops
- Wideband AGC
- High Crest Factor Measurements
- SCR Power Monitoring

DESCRIPTION

The LT1088 is a thermally based RMS-DC converter building block. It converts the input waveform to heat. Using external circuitry, the thermal signal is expressed as a DC output voltage.

LTC's proprietary thermal packaging process permits accurate thermal signal processing in a standard IC package. The thermal method provides far greater bandwidth than RMS converters based on logarithmic computing techniques. The LT1088's high voltage breakdown allows crest factor measurements of 50:1 and operation over a 20:1 input dynamic range. Resistive inputs of 50Ω or 250Ω accommodate drive from a wide variety of sources.

Simplified RMS-DC Converter

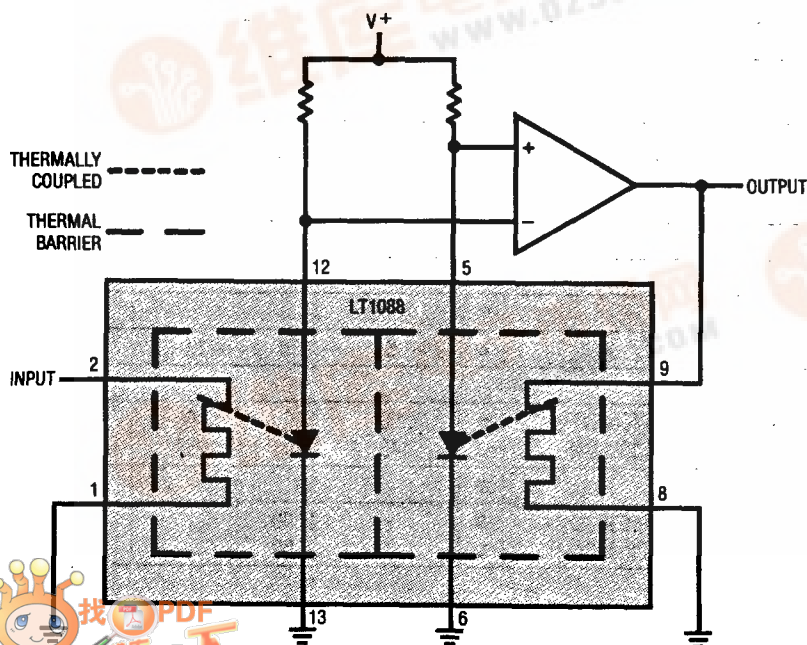

Accuracy vs Frequency (50Ω Input)

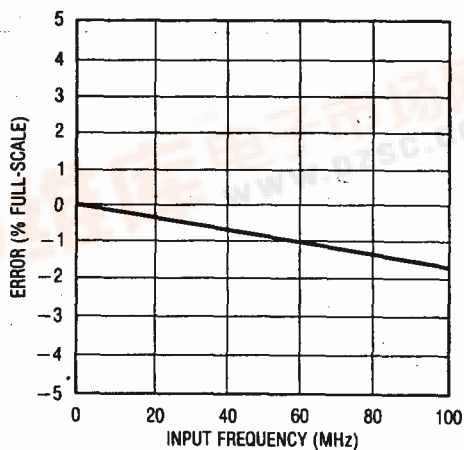

LT1088

ABSOLUTE MAXIMUM RATINGS

| | |
|--|--------------------------------|
| Voltage on Any Pin | $V^- + 40V$ to V^- |
| Voltage from Channel A to Channel B | 100V |
| Reverse Diode Voltage | 3.5V |
| Forward Diode Current | 15mA |
| Input Power (25°C) | 0.375W |
| Peak Input Power (30 sec) | 0.435W |
| Derate Power at $-3mW/^\circ C$ above 25°C | |
| Maximum Die Temperature | 150°C |
| Peak Die Temperature (30 sec) | 175°C |
| Functional Temperature Range | $-55^\circ C$ to $125^\circ C$ |
| Operating Temperature Range | $-40^\circ C$ to $85^\circ C$ |
| Lead Temperature (Soldering, 10 sec) | 300°C |

PACKAGE/ORDER INFORMATION

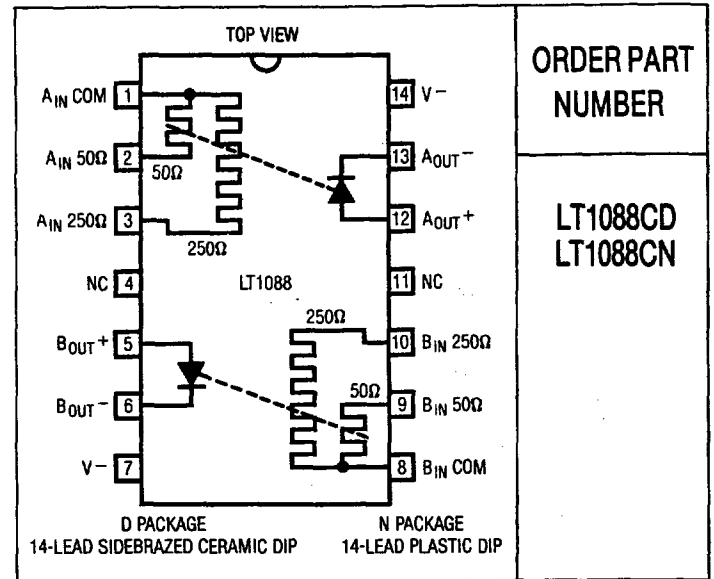

ORDER PART NUMBER

LT1088CD
LT1088CN

ELECTRICAL CHARACTERISTICS $T_A = 25^\circ C$, unless otherwise noted (See Note 1)

| PARAMETER | CONDITIONS | MIN | TYP | MAX | UNITS | | |
|---|---------------------------|----------|------|-------|--------|-------|------|
| Input Heaters | | | | | | | |
| 50Ω Input | | 40 | 50 | 60 | Ω | | |
| 250Ω Input | | 200 | 250 | 300 | Ω | | |
| 50Ω Temperature Coefficient | | ● | 2000 | | ppm/°C | | |
| 250Ω Temperature Coefficient | | ● | 2000 | | ppm/°C | | |
| 50Ω Temperature Coefficient Match | Input A to Input B | ● | 30 | 500 | ppm | | |
| 250Ω Temperature Coefficient Match | Input A to Input B | ● | 30 | 500 | ppm | | |
| Resistance Matching | 50Ω Inputs | | 2 | 10 | % | | |
| | 250Ω Inputs | | 2 | 10 | % | | |
| 250Ω to 50Ω Ratio Match | | -15 | 0 | 5 | % | | |
| 250Ω to 50Ω Ratio Match Temperature Coefficient | | ● | 50 | | ppm/°C | | |
| Output Diodes | | | | | | | |
| Forward Voltage | $I = 5mA$ | 0.6 | 0.7 | 0.8 | V | | |
| Forward Voltage Match | Out A to Out B; $I = 5mA$ | ● | 5 | | mV | | |
| Voltage Temperature Coefficient | $I = 5mA$ | ● | -1.6 | -1.75 | -1.9 | mV/°C | |
| Thermal Characteristics | | | | | | | |
| Thermal Resistance | Either Die to Ambient | LT1088CD | ● | 200 | 300 | 400 | °C/W |
| | | LT1088CN | ● | 140 | 210 | 280 | °C/W |
| Thermal Matching | Channel A to Channel B | ● | 30 | | | °C/W | |
| Thermal Cross Talk | Channel A to Channel B | LT1088CD | ● | 2500 | | | °C/W |
| | | LT1088CN | ● | 1750 | | | °C/W |

The ● denotes specifications which apply over full operating temperature range.

Note 1: All electrical testing conducted at 25°C.

TYPICAL PERFORMANCE CHARACTERISTICS

Figure 4's Response vs Frequency—50Ω Input

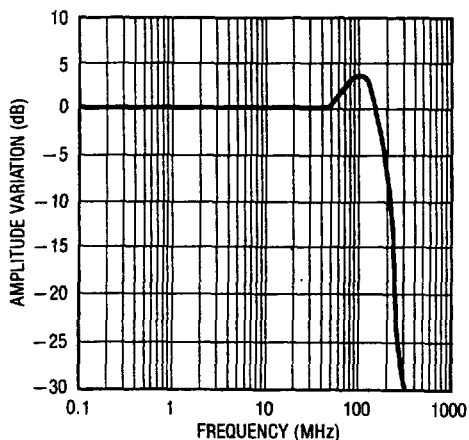
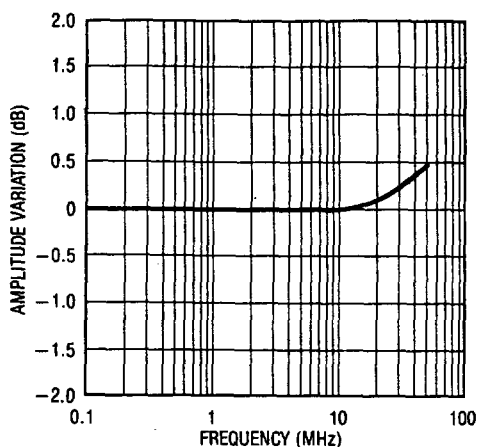
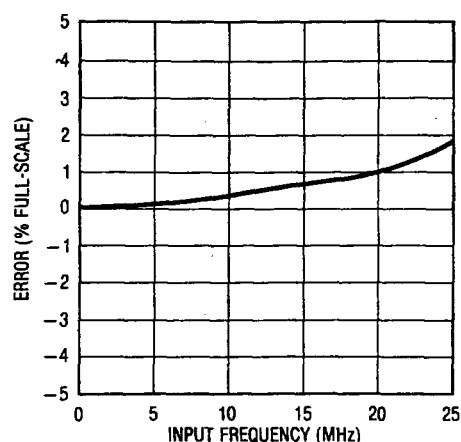

Figure 4's Response vs Frequency—250Ω Input



Accuracy vs Frequency for Figure 4—250Ω Input



Distribution of Diode Offset Voltage

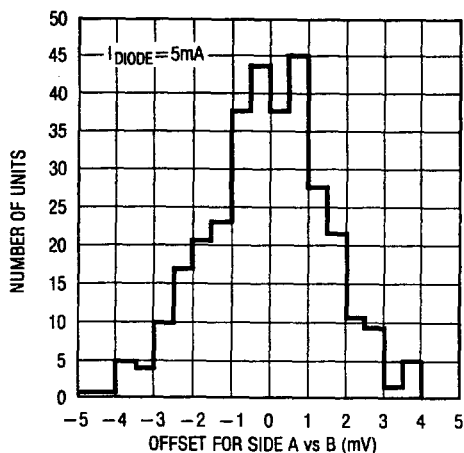

Distribution of Thermal Resistance

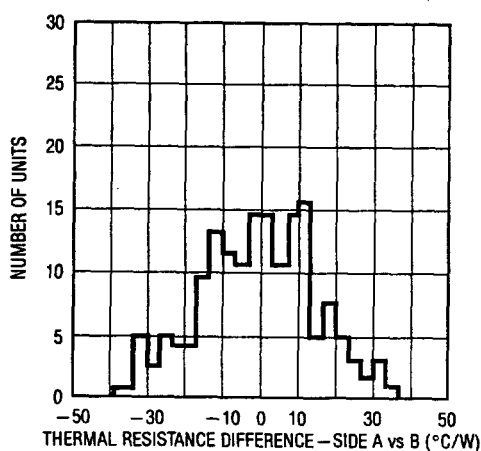

Heater Resistance vs RMS Volts—250Ω Heater

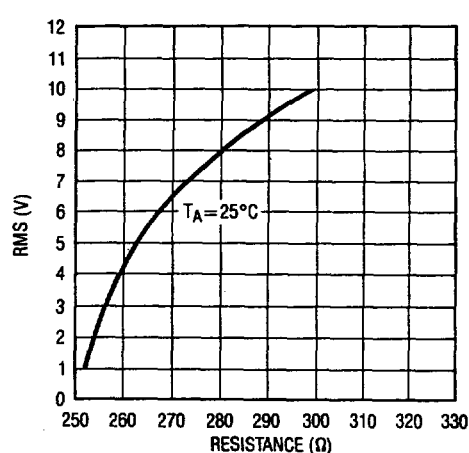

Heater Resistance vs RMS Volts—50Ω Heater

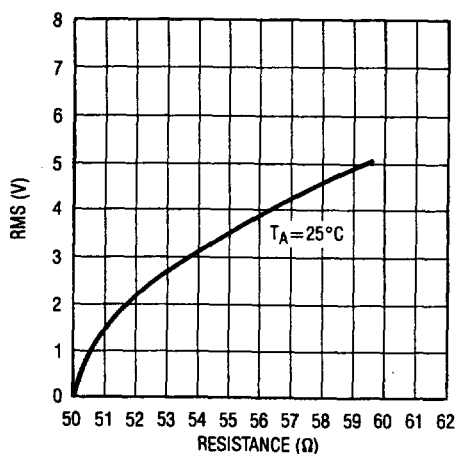
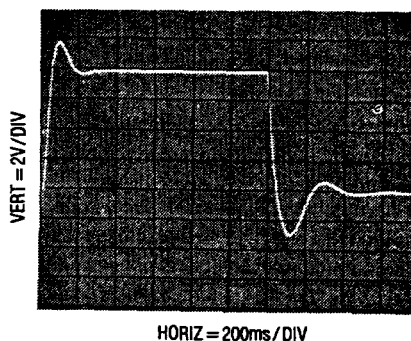

Figure 4's Settling Time (LT1088CD)



APPLICATIONS INFORMATION

Pin Functions

A_{IN} 50Ω, B_{IN} 50Ω, A_{IN} 250Ω, B_{IN} 250Ω (Pins 2, 9, 3, 10): Heater input pins. Input and servo amplifier are connected to these pins. Since the LT1088 is symmetrical, either channel A or B may be used as the input. For higher input impedance, the 50Ω and 250Ω heaters may be series connected. No heater pin may be below V⁻ or more than 40V above V⁻. Maximum heater dissipation must not exceed the absolute maximum ratings.

A_{IN} COM, B_{IN} COM (Pins 1, 8): Common point for the 50Ω and 250Ω input heaters, usually tied to ground.

A_{OUT}⁺, B_{OUT}⁺ (Pins 12, 5): High side of the temperature sensing diodes. Normally they are driven at 5mA from the positive supply. No diode pin may be below V⁻ or more than 40V above V⁻.

A_{OUT}⁻, B_{OUT}⁻ (Pins 13, 6): Low side of the temperature sensing diodes. These pins are normally tied to ground. No diode pin may be below V⁻ or more than 40V above V⁻.

V⁻ (Pins 7, 14): These pins must be the most negative potential of the circuit, usually tied to ground.

Parasitic Diodes

As with all bipolar ICs the LT1088 contains parasitic diodes which must not be forward biased. The parasitic diodes, marked with asterisks, appear in Figure 1. The

dashed lines indicate that all points of the heaters are parasitically diode connected to V⁻.

Thermal Considerations

Because the LT1088's operation depends on thermal symmetry, it is sensitive to external temperature gradients. This is particularly the case for small inputs, which cause the device to run very close to ambient temperature. The device should be mounted in an area which is isothermal and free of drafts. Power generating components should be kept away from the LT1088 and particular caution taken in fan cooled equipment. Under normal conditions no thermal baffle or enclosure is required. Under no circumstances should a heat sink be used.

Heater Protection

Most LT1088 failures will be caused by excessive heater drive. Input power (25°C) is specified at 375mW with 30 second excursions to 435mW permitted. These figures are derated by -3mW/°C above 25°C. Figure 2 plots safe operating limits for input duty cycle vs input voltage. Accidental heater overdrives can damage or destroy the LT1088. In situations where overdrive may occur, some form of heater protection should be employed. Suggested circuits appear in the applications section.

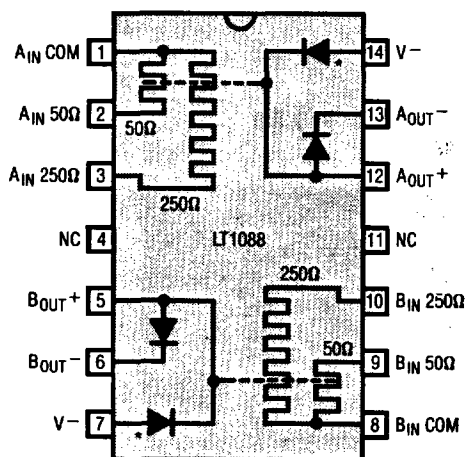

*DENOTES PARASITIC DIODE, SEE APPLICATIONS INFORMATION

Figure 1

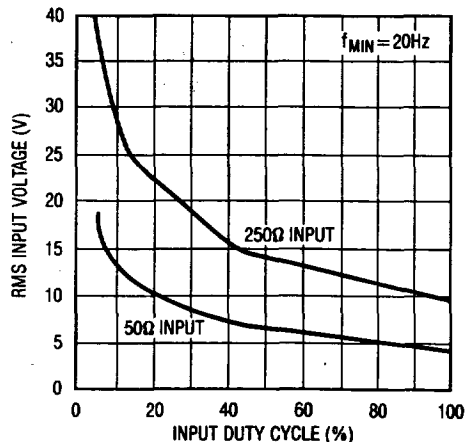

Figure 2. Safe Operating Limits

APPLICATIONS INFORMATION

Filtering

The LT1088's thermal time constant provides effective low pass filtering. Low frequency cut-off is set by servo loop time constants. For the 3300pF value given in the basic RMS-DC application, the circuit begins to follow the input below about 50Hz. Normally, this is not a problem, because the LT1088's primary application will be at high frequency. Lower frequency operation is obtainable by increasing the 3300pF value, although settling time will increase proportionally.

Crest Factor

Crest factor is defined as the ratio of peak input voltage to RMS value. Crest factor performance is set by IC breakdown limits and the usable low input power range. Breakdown limits are a function of processing. The usable low input power range is a basic signal-to-noise conflict. Low input power produces small amounts of signal. This makes accurate, stable discrimination between desired inputs and ambient thermal phenomena uncertain and noisy. These constraints set crest factor at 50:1 for the 50Ω input and 40:1 for the 250Ω input.

Layout

At frequencies above 10MHz, input connections require care. Parasitic inductance builds quickly in wire runs, so

the LT1088's input heater lead should be *directly* connected to the source to be measured. It is also wise to shield the input line from the rest of the circuit. The heater common should be returned directly to a ground plane. An additional precaution is to mount the 0.01μF bypass capacitors right at the LT1088 package. These units minimize the effects of RF pick-up by the temperature sensing diodes.

Accuracy

Amplitude measurement at high frequency to significant accuracy is difficult because of parasitic effects. At frequencies much above 5MHz, small parasitic capacitive and inductive terms become important. The accuracy figures quoted for the applications circuits were taken against certified standards utilizing direct and transfer techniques. Thermal transfer standards (Fluke Model 540B with A-55 converters) certified to 50MHz were used as references. The data above 50MHz was also taken with these references, although the individual units used had not been certified at these frequencies. The accuracy of units of this type which have been certified is normally inside the tolerances listed, so there is good probability the data is valid.

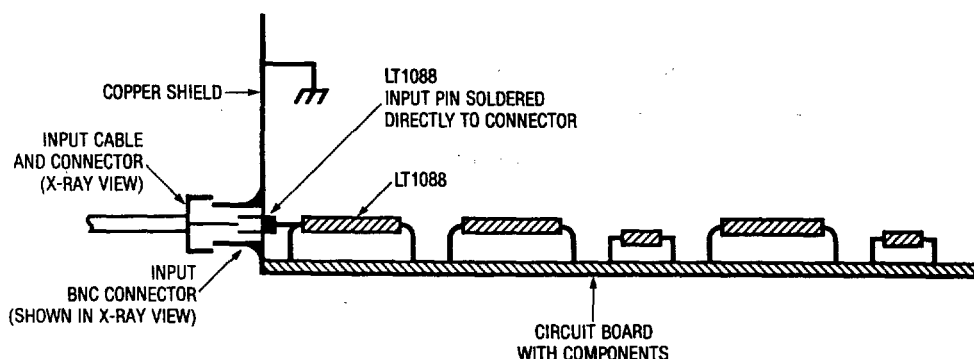

Figure 3. Typical Evaluation Layout

APPLICATIONS INFORMATION

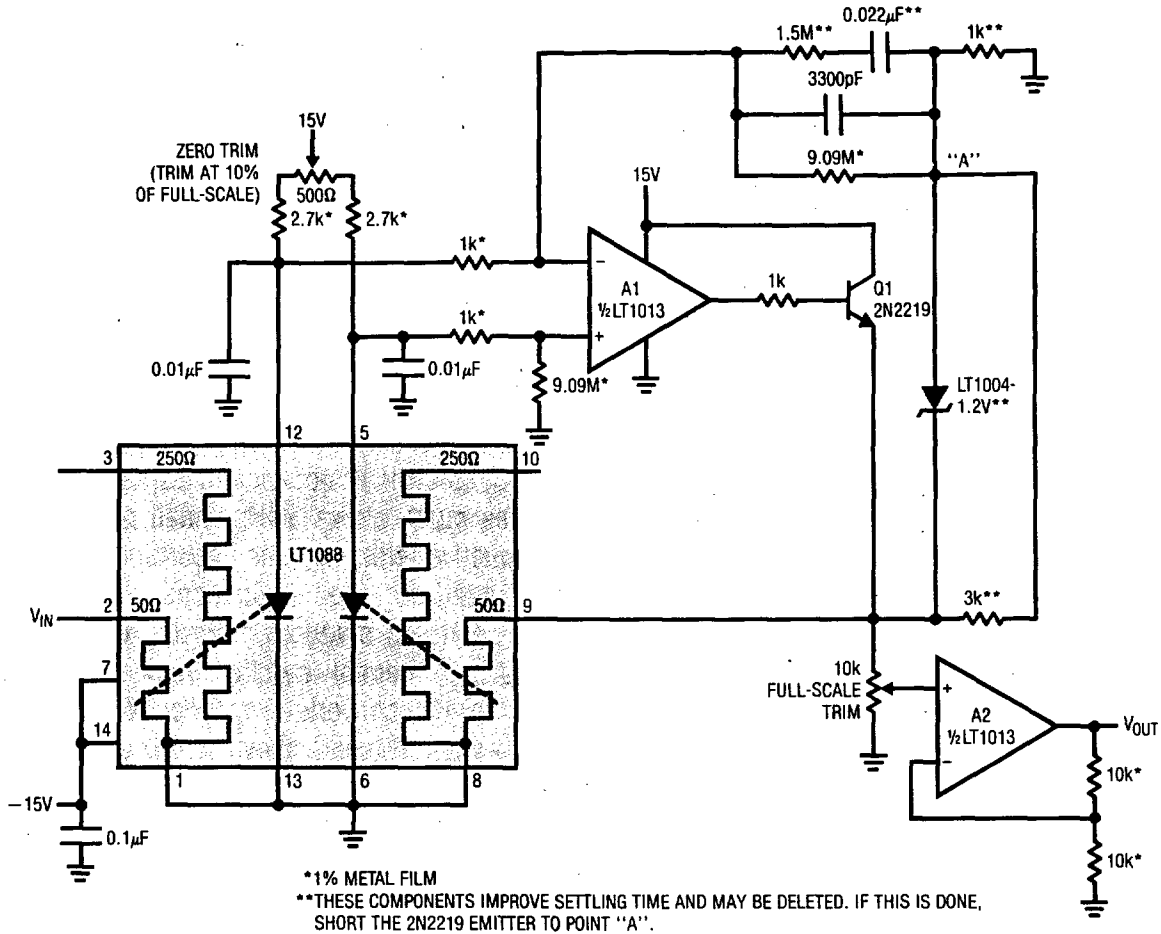

Figure 4. Basic RMS-DC Converter

Figure 4's Typical Specifications

| | |
|---|--|
| Accuracy: | Crest Factor: |
| 50Ω Input | 50Ω Input 50:1 |
| DC to 50MHz 1% FS | 250Ω Input 40:1 |
| DC to 100MHz 2% FS | 3dB Bandwidth 300MHz |
| 250Ω Input | Full-Scale Settling Time (1%) 500ms (LT1088CD) |
| DC to 20MHz 1% FS | 710ms (LT1088CN) |
| Temperature Effect on Accuracy 100ppm/°C | Input Voltage Range (25°C) |
| Dynamic Range 20:1 (LT1088CD)/14:1 (LT1088CN) | 50Ω Input 4.25V |
| | 250Ω Input 9.5V |

APPLICATIONS

Servo-Sensed Heater Protection Circuit ($\approx 50\text{ms}$ Response)

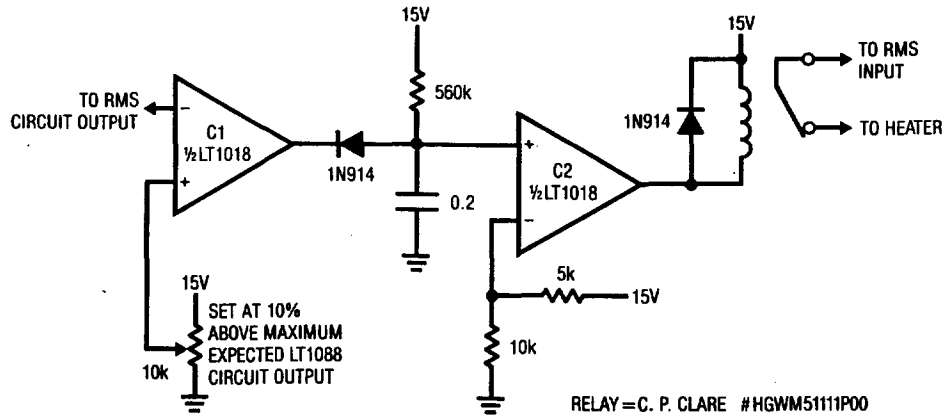

Diode Sensed Heater Protection Circuit ($\approx 15\text{ms}$ Response)

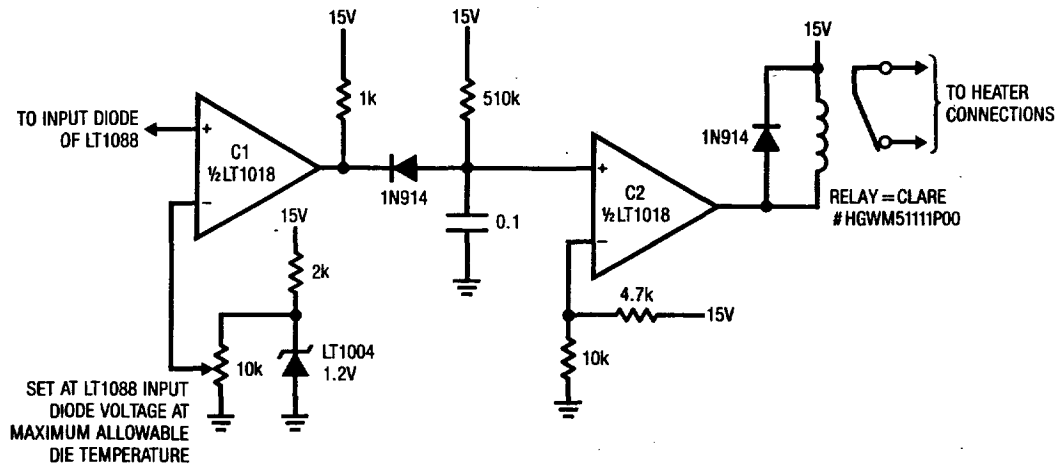

Discrete Input Buffer for the LT1088

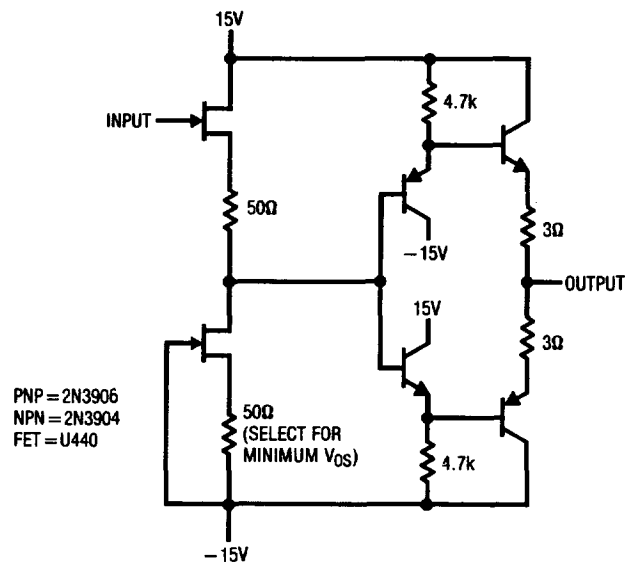

APPLICATIONS

LT1010 Buffer†

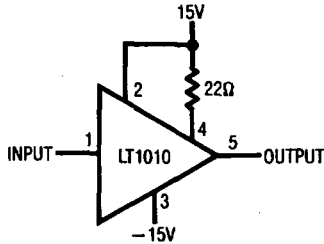

LT1010 Buffer with Gain of 10†

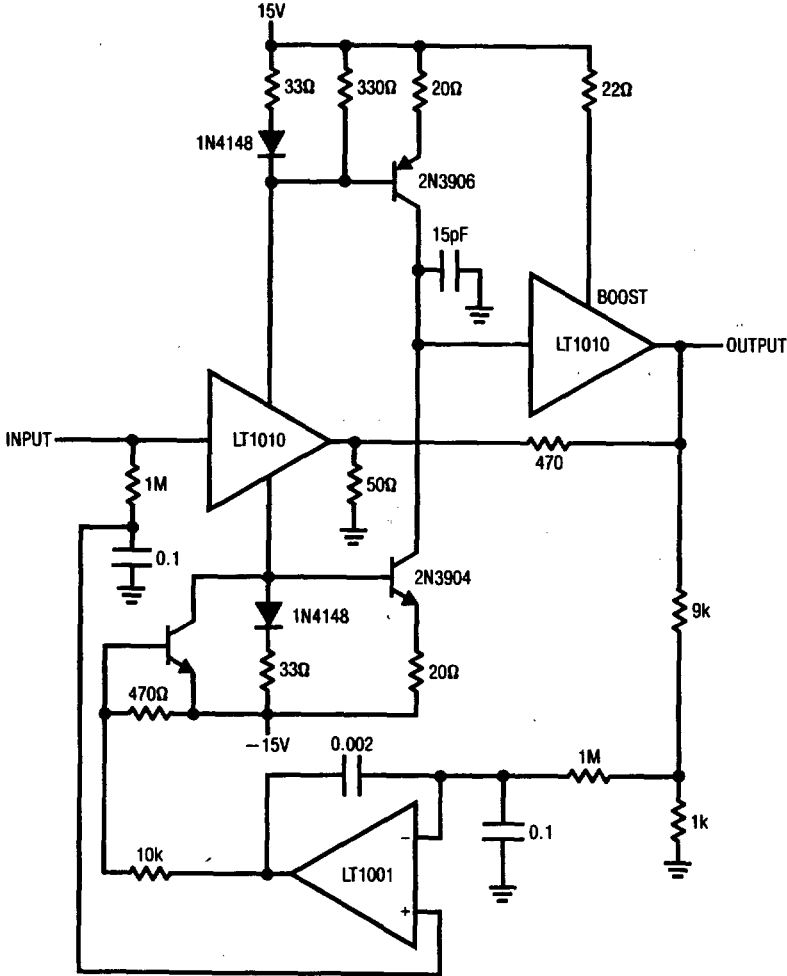

† See Summary of Buffer Characteristics table for buffer speed.

APPLICATIONS

Wideband Discrete Buffer with Gain = 10†

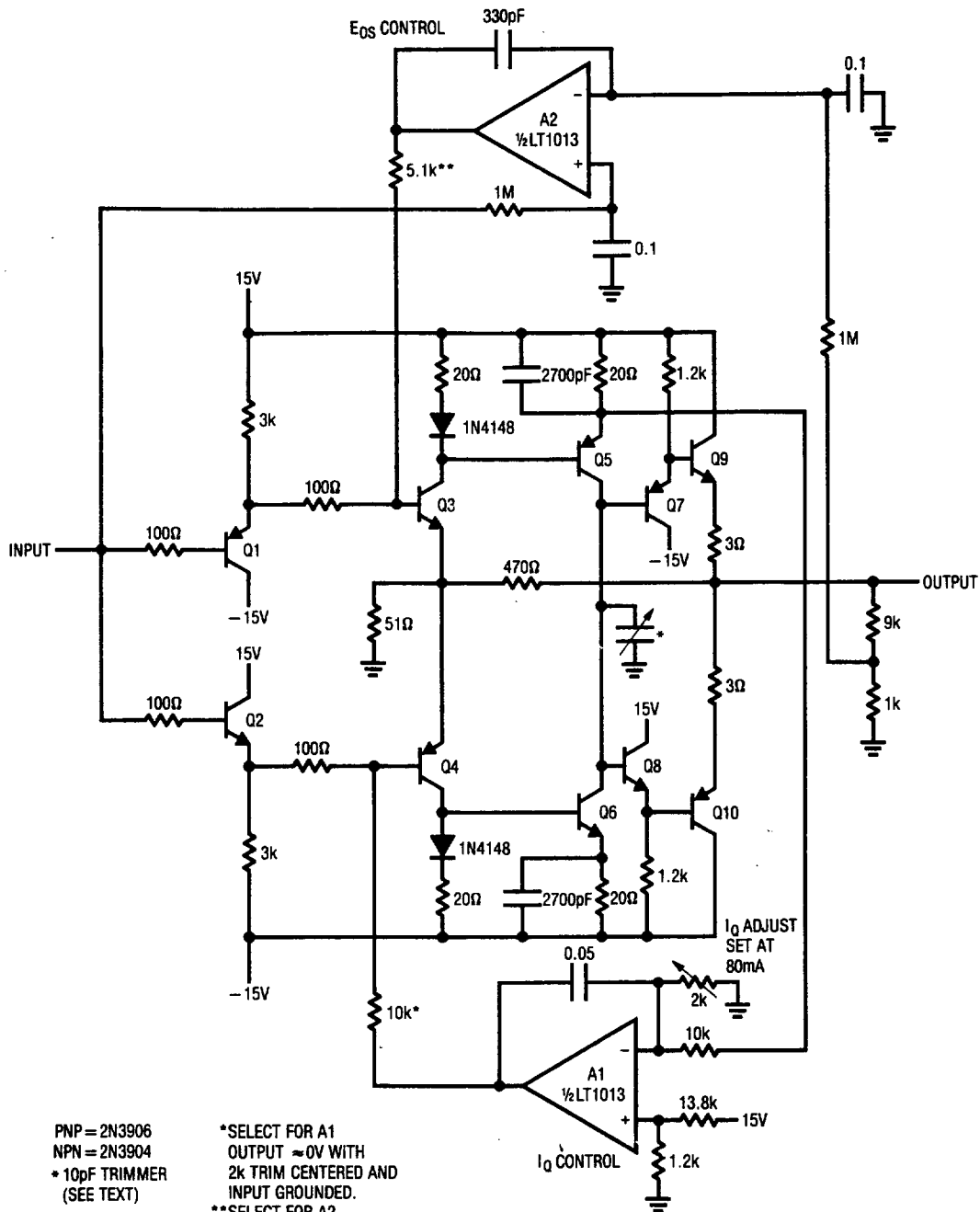

† See Summary of Buffer Characteristics table for buffer speed.

APPLICATIONS

Summary of Buffer Characteristics

| Type of Buffer | Slew Rate | 1% Error Bandwidth | |
|---------------------|-----------|-------------------------------------|-----------------------------------|
| | | 250Ω Load (±10V _{OUT}) | 50Ω Load (±5V _{OUT}) |
| Discrete—A = 10 | 3000V/μs | 25MHz | 32MHz |
| LT1010 Based—A = 10 | 100V/μs | 0.75MHz | 2MHz |
| Discrete—A = 1 | 2000V/μs | 15MHz | 25MHz |
| LT1010 Based—A = 1 | 100V/μs | 0.75MHz | 2MHz |

RF Leveling Loop

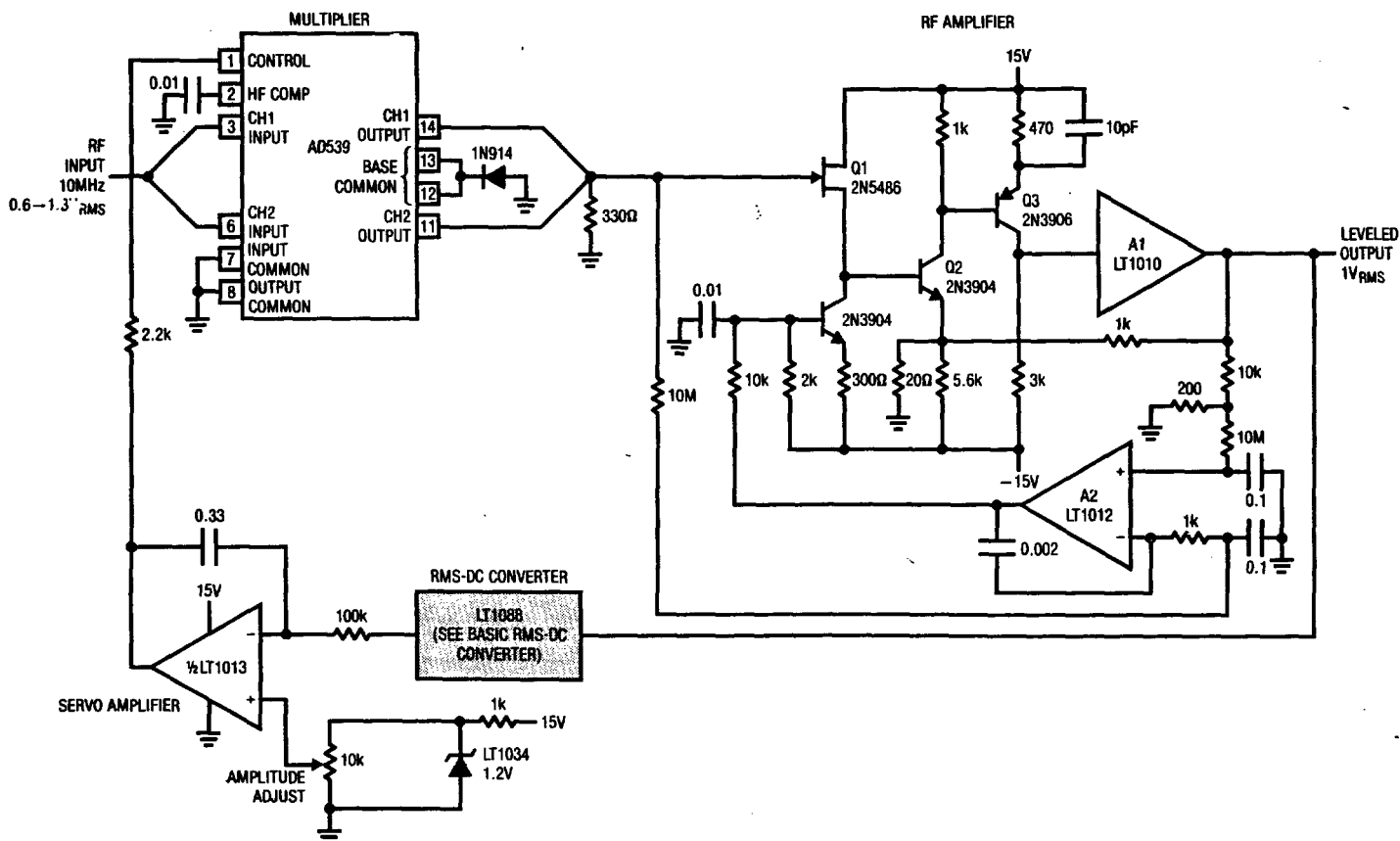

PACKAGE DESCRIPTION Dimensions in inches (millimeters) unless otherwise noted.

D Package
14-Lead Sidebraced Ceramic DIP

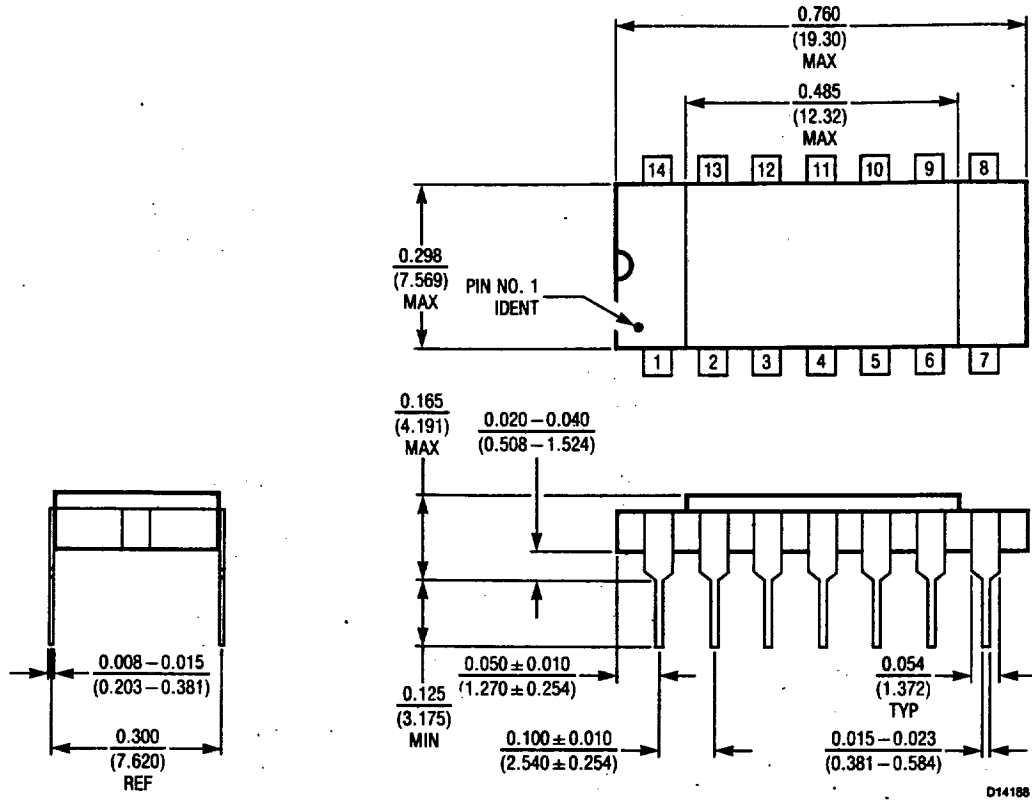

D14188

N Package
14-Lead Plastic DIP

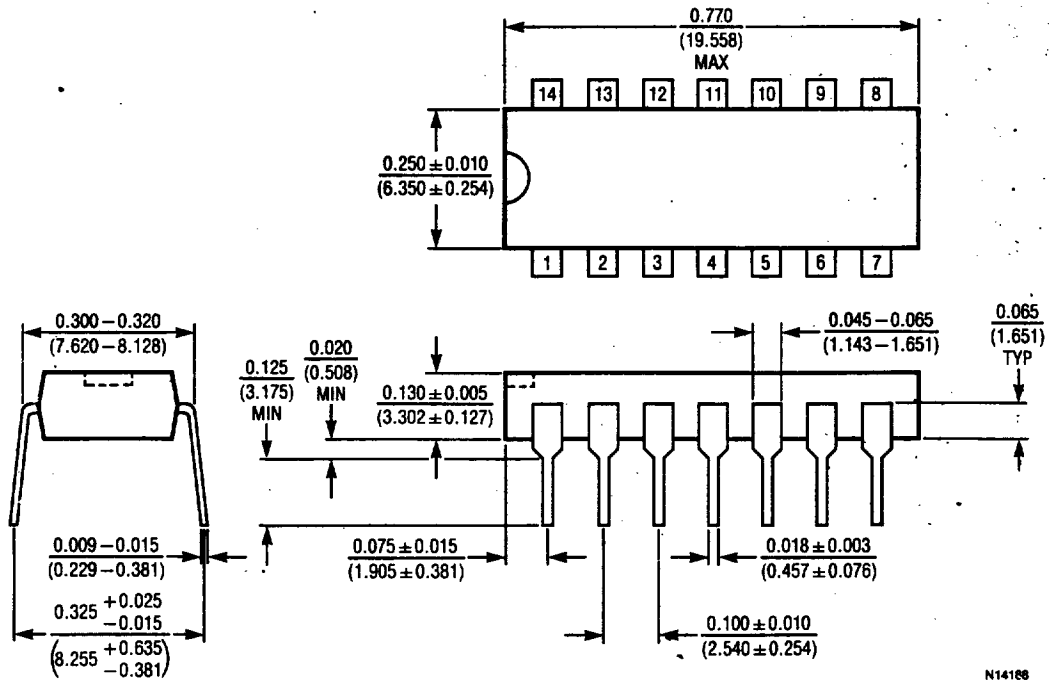

N14188