



T-45-19-05

# SP8629

150MHz ÷ 100

The SP8629 is an ECL counter which provides a TTL compatible output, high input sensitivity and low power consumption. Pin compatible with DM8629, it features a much lower power consumption.

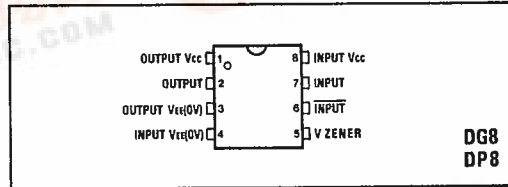

Fig.1 Pin connections - top view

### FEATURES

- TTL/CMOS Compatible Output
- High Input Sensitivity
- Ideal Frequency Counter Prescaler
- On Chip Zener Diode

### QUICK REFERENCE DATA

- Supply Voltage: 5V
- Power Consumption: 170mW
- Temperature Range: -40°C to +85°C

### ABSOLUTE MAXIMUM RATINGS

Supply voltage (Pins 1 and 8)	8V
Output current	40mA
Storage temperature range	-55°C to +125°C
Max. junction temperature	+175°C
Max. clock I/P voltage	2.5V p-p

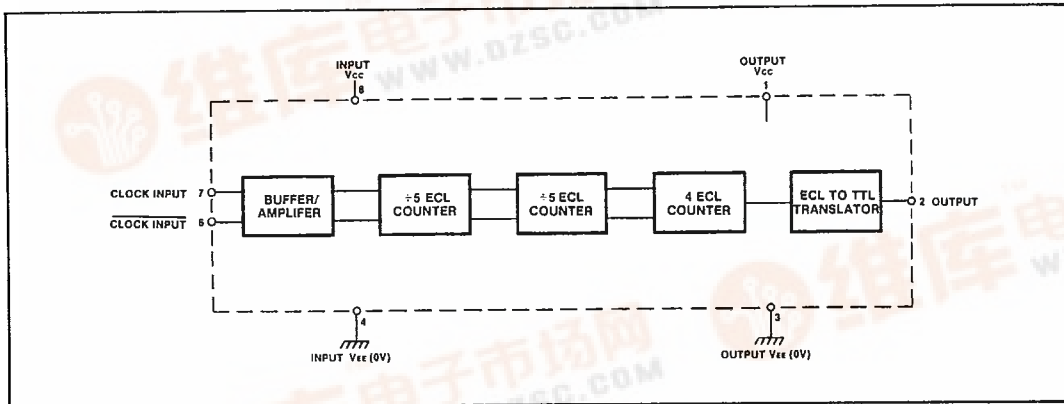

Fig.2 SP8629 logic diagram



**ELECTRICAL CHARACTERISTICS**

Supply Voltage:  $V_{CC} = 5.2V \pm 0.52V$   $V_{EE} = 0V$   
 Temperature:  $T_{amb} -40^{\circ}C$  to  $+85^{\circ}C$

T-45-19-05

Characteristics	Symbol	Value		Units	Conditions
		Min.	Max.		
Maximum toggle frequency sinewave input	$f_{max}$	150		MHz	Input = 200-1000mV p-p
Minimum toggle frequency sinewave input	$f_{min}$		10	MHz	Input = 600-1000mV p-p
Power supply current	$I_{EE}$		45	mA	
Output high voltage	$V_{OH}$	2.4		V	$V_{CC} = 4.68V$ $I_{OH} = -400\mu A$
Output high voltage	$V_{OH}$	2.0		V	$V_{CC} = 4.68V$ $I_{OH} = -1.6mA$
Output low voltage	$V_{OL}$		0.5	V	$V_{CC} = 5.72V$ $I_{OL} = 8mA$
Output short circuit current	$I_{OS}$	-10	-40	mA	$V_{CC} = 5.72V$
Internal zener voltage	$V_z$	5.85	6.65	V	

**NOTES**

1. Unless otherwise stated the electrical characteristics shown above are guaranteed over specified supply, frequency and temperature range.
2. The dynamic test circuit is shown in Fig.5.
3. All characteristics above are tested at 25°C only.

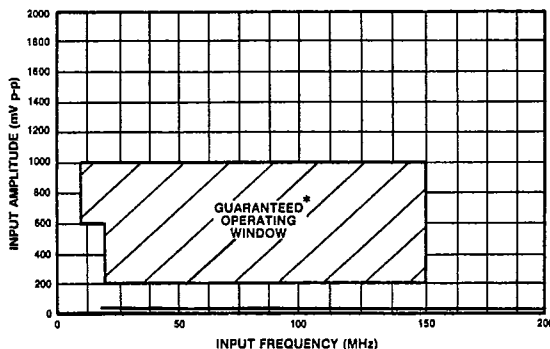

\* Tested as specified in table of Electrical Characteristics

Fig.3 Typical input characteristics SP8629

**OPERATING NOTES**

1. Two  $V_{EE}$  and two  $V_{CC}$  connections are provided, separating the ECL stages from the TTL section, isolating the noise transients inherent in the TTL structure. In most cases, shorting the two  $V_{EE}$  pins to a good ground plane and the  $V_{CC}$  pins to a wide  $V_{CC}$  bus will provide sufficient isolation. All components used in the circuit layout should be suitable for the frequencies involved and leads should be kept short to minimise stray inductance.
2. The signal source is usually capacitively coupled to the input as shown in Fig. 6. In the single-ended mode a capacitor of 0.01 $\mu F$  (C2) should be connected between the unused input and the ground plane to provide a good high frequency bypass. The capacitor should be increased at lower frequencies. If the input is likely to be interrupted, it may be desirable to connect a 100k resistor between an input and ground.
3. In the single ended mode it is preferable to connect the resistor to the unused input. The addition of the 100k resistor causes a loss of input sensitivity, but prevents circuit

- oscillations under no signal (open circuit) conditions.
4. The input waveform will normally be sinusoidal but below 10MHz correct operation depends on the slew rate of the input signal. A slew rate of 50V/ $\mu s$  will enable the device to operate down to DC. The device will operate with a TTL input signal as shown in Fig. 7 and is DC coupled to the input. The device can be used in phase locked loop applications such as FM radio or other communications bands to prescale the input frequency down to a more useable level. A digital frequency display system can also be derived separately or in conjunction with a phase locked loop, and it can extend the useful range of many inexpensive frequency counters to, typically, 200MHz.
5. The on-chip Zener diode allows a simple stabilised power supply to be constructed with the addition of a few extra external components, as shown in Fig. 8, to the SP8629.
6. The INPUT is positive edge triggered while the  $\overline{INPUT}$  triggers on the negative edge.

T-45-19-05

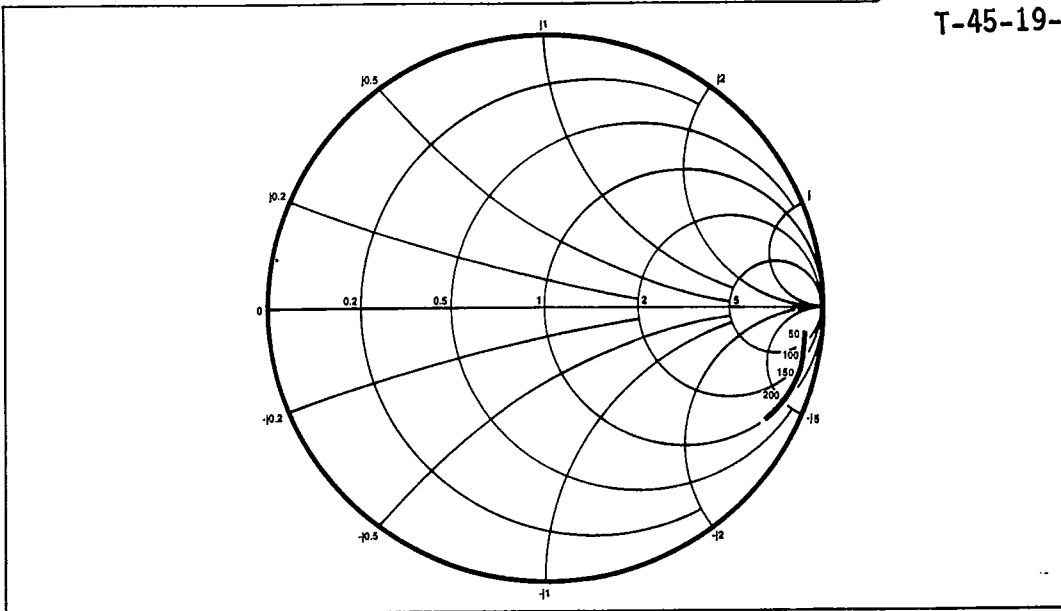

Fig.4 Typical input impedance. Test conditions: supply voltage 5.2V, ambient temperature 25°C. Frequencies in MHz, impedances normalised to 50 ohms.

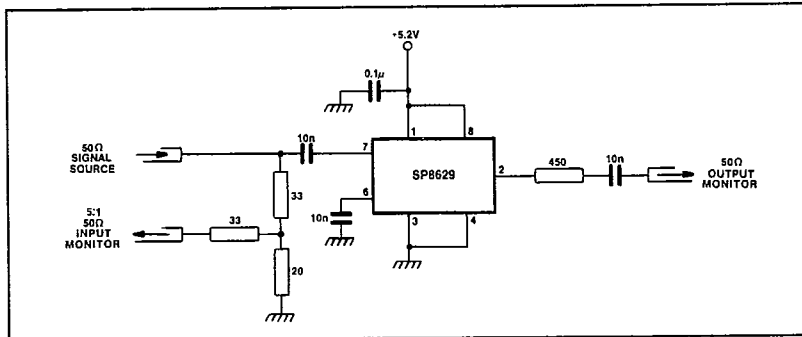

Fig.5 Test circuit

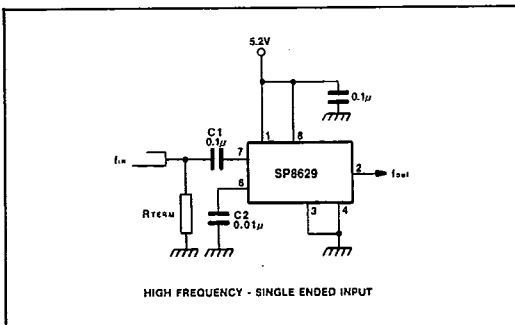

Fig.6 High frequency, single-ended input

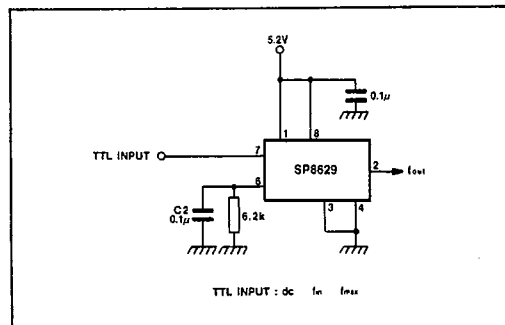

Fig.7 TTL input (DC  $I_{in} < I_{max}$ )

T-45-19-05

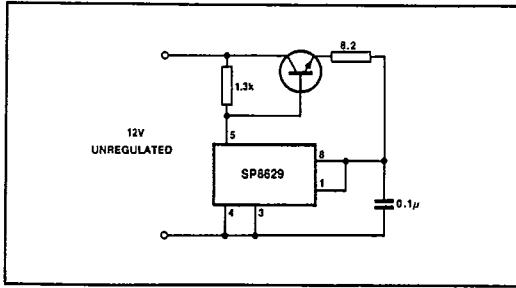

Fig.8 Use of on-chip zener diode for operation from unregulated supply

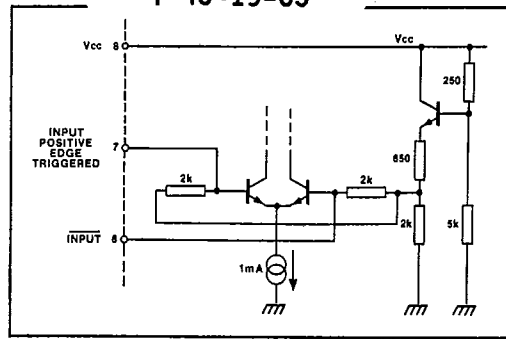

Fig.9 Input circuit diagram

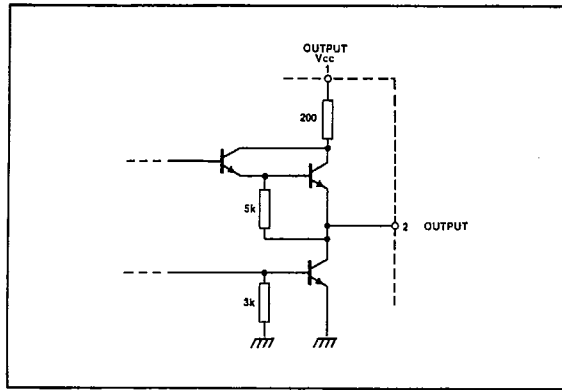

Fig.10 Output circuit diagram