

OKI Semiconductor

This version: Nov. 1997
Previous version: Mar. 1996

MSM6255

DOT MATRIX LCD CONTROLLER

GENERAL DESCRIPTION

The MSM6255 is a CMOS si-gate LSI designed to display characters and graphics on a DOT MATRIX LCD panel.

FEATURES

- Display control capacity
 - Graphic mode : 512,000 dots (2^{16} bytes)
Memory address MA₀ to MA₁₅
 - Character mode : 65,536 characters (2^{16} bytes)
Display address MA₀ to MA₁₅
- Direct interface with 8085 or Z80 CPU
- Duty : 1/2 to 1/256 selectable
- Attributes
 - Screen clear
 - Cursor ON/OFF/blink
- Scrolling and paging
- Display system : AC inversion at each frame
- Data output (upper and lower display outputs)
4-bit parallel output, 2-bit parallel output, 1-bit serial output
- Crystal oscillation/external clock selectable
- Single +5V power supply
- Package options:
 - 80-pin plastic QFP (QFP80-P-1420-0.80-K) (Product name: MSM6255GS-K)
 - 80-pin plastic QFP (QFP80-P-1420-0.80-BK) (Product name: MSM6255GS-BK)

BLOCK DIAGRAM

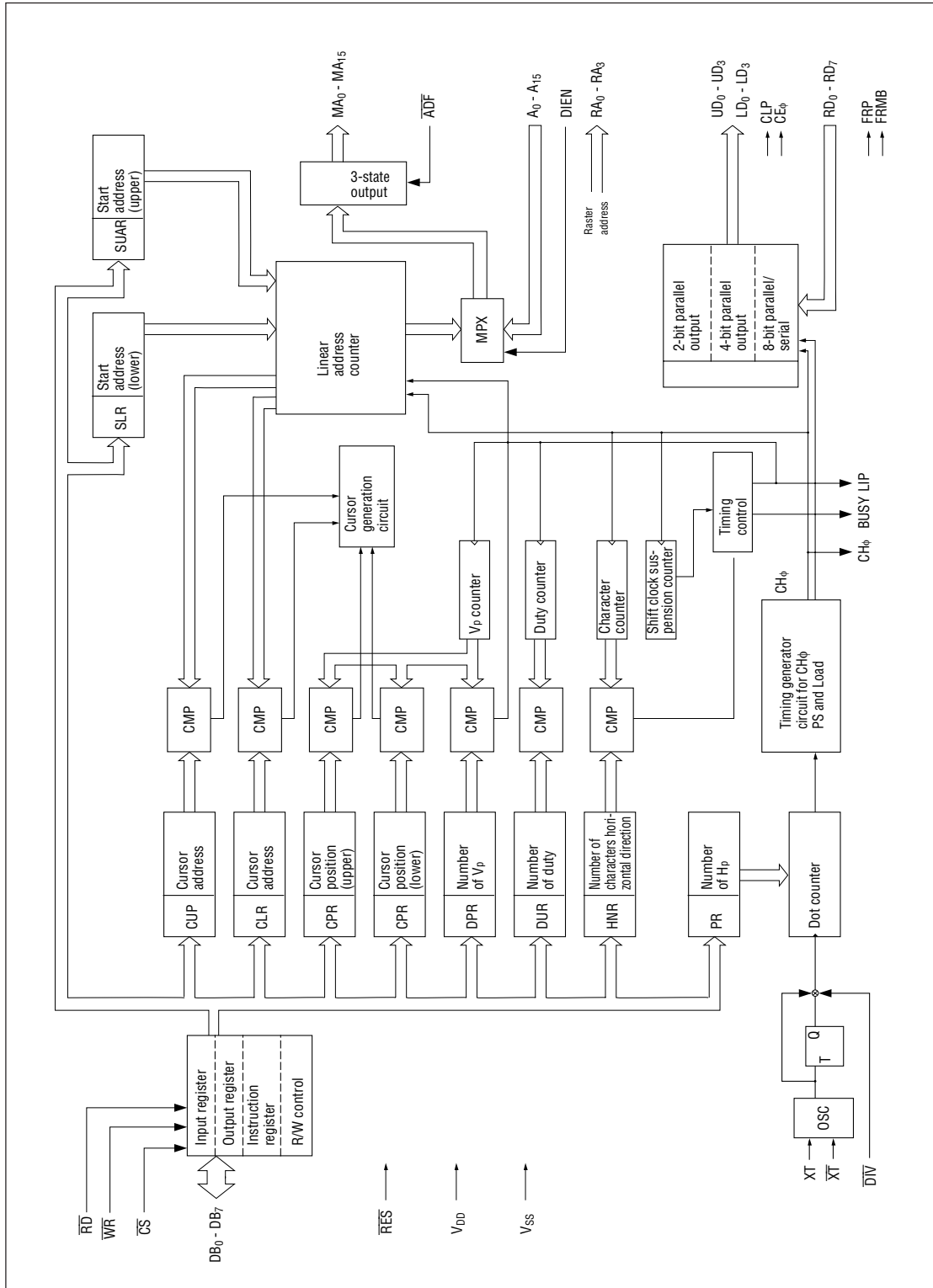

PIN CONFIGURATION (TOP VIEW)

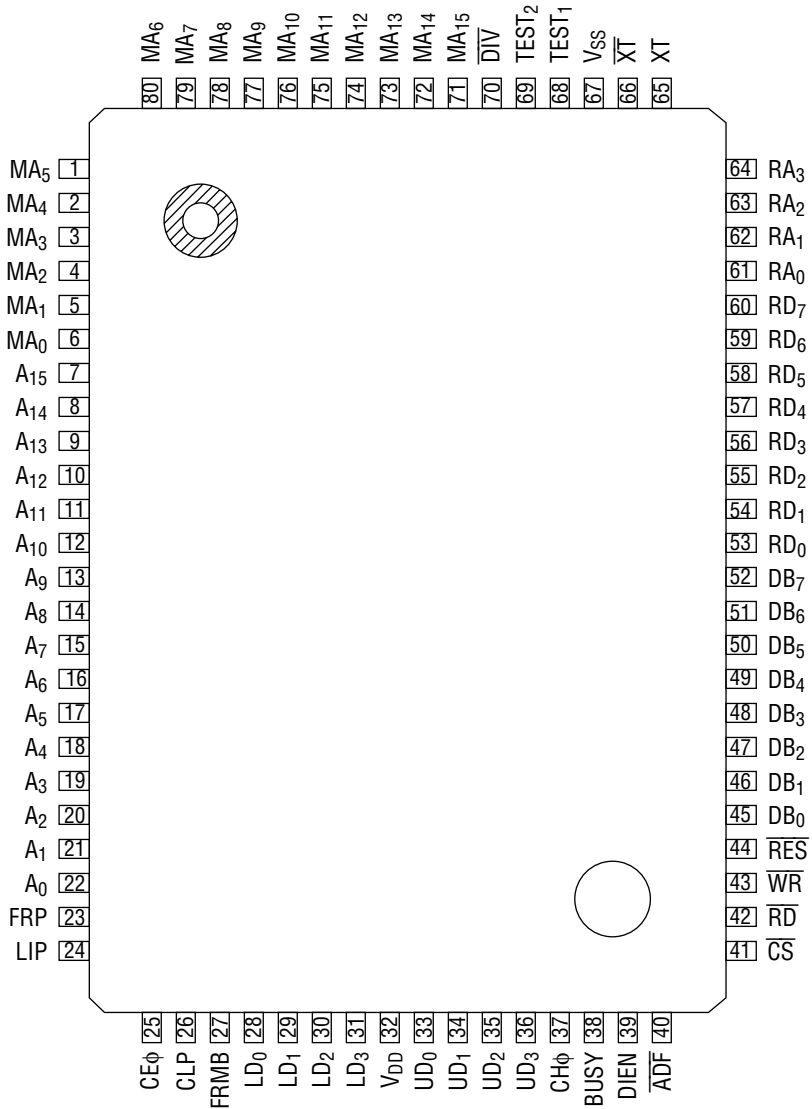

80-Pin Plastic QFP

PIN DESCRIPTIONS

Pin	Symbol	Type	Description
1 - 6 71 - 80	MA ₀ MA ₁₅	0	Address output for displaying RAM. MA ₀ - MA ₁₅ are high impedance when \overline{ADF} = "L".
7 22	A ₀ A ₁₅	1	Memory address input pins
23	FRP	0	Frame signal. Synchronization of display
24	LIP	0	Display data latch signal
25	CE ϕ	0	Chip enable clock for LCD segment driver
26	CLP	0	Display data shift clock
27	FRMB	0	Alternate signal output pin
28 31	LD ₀ LD ₃	0	Display data parallel output for lower side
32	V _{DD}	0	Supply voltage
33 36	UD ₀ UD ₃	0	Display data parallel output, Upper display 4-bit output (OD1, ED1, OD2 and ED2 outputs)
37	CH ϕ	0	Character clock
38	Busy	0	Ready state signal. This signal is used while serial transmission stops.
39	DIEN	1	Display enable signal. When this signal is "H", display is enabled.
40	\overline{ADF}	1	Address floating input. When this signal is "L", MA ₀ - MA ₁₅ , RA ₀ - RA ₃ are high impedance, and when it is "H", A ₀ - A ₁₅ or a refresh address is output to MA ₀ - MA ₁₅ .
41	\overline{CS}	1	Chip select. \overline{CS} = "L"
42	\overline{RD}	1	Read. Reading data is valid when \overline{RD} = "L"
43	\overline{WR}	1	Write. Data is written when \overline{WR} = "H"
44	\overline{RES}	1	Reset. Resets each counter.
45 52	DB ₀ DB ₇	I/O	8-bit data bus. Common pins for 3-state I/O.
53 60	RD ₀ RD ₇	1	ROM/RAM data input. Dot pattern data for the character generator
61 64	RA ₀ RA ₃	0	Raster address output. *This output is not used in the graphic mode. RA ₀ - RA ₃ are high impedance when \overline{ADF} = "L".
65	XT	1	X'tal osc. When an external clock is used by setting \overline{DIV} to "H", feeds it to XT.
66	\overline{XT}	0	
67	V _{SS}	—	Ground pin.
70	\overline{DIV}	1	"H" : EXT clock

ABSOLUTE MAXIMUM RATINGS

Parameter	Symbol	Condition	Rating	Unit
Supply Voltage	V_{DD}	$T_a = 25^\circ\text{C}$	-0.3 to +6	V
Input Voltage	V_I	$T_a = 25^\circ\text{C}$	-0.3 to V_{DD}	V
Storage Temperature	T_{STG}	—	-50 to +150	$^\circ\text{C}$

RECOMMENDED OPERATING CONDITIONS

Parameter	Symbol	Condition	Range	Unit
Supply Voltage	V_{DD}	$V_{SS} = 0\text{V}$	4.5 to 5.5	V
Operating Temperature	T_{op}	—	-20 to +85	$^\circ\text{C}$
Operating Frequency	f_{osc}	$V_{DD} = 5\text{V} \pm 10\%$	0 to 11	MHz

ELECTRICAL CHARACTERISTICS

Input Characteristics

($V_{DD} = 5\text{V} \pm 5\%$, $T_a = -20$ to $+85^\circ\text{C}$)

Parameter	Symbol	Min.	Typ.	Max.	Unit	Applicable pin
"H" Input Voltage	V_{IH}	2.4	—	—	V	DB ₀ - DB ₇ , $\overline{\text{CS}}$, $\overline{\text{RD}}$, $\overline{\text{WR}}$, A ₀ - A ₁₅ , DIEN, ADF, RD ₀ - RD ₇
"L" Input Voltage	V_{IL}	—	—	0.7	V	
"H" Input Voltage	V_{IH}	4.5	—	—	V	$\overline{\text{RES}}$, $\overline{\text{DIV}}$, XT
"L" Input Voltage	V_{IL}	—	—	1.0	V	
"H" Input Current	I_{IH}	—	—	1	μA	DB ₀ - DB ₇ , $\overline{\text{CS}}$, $\overline{\text{RD}}$, $\overline{\text{WA}}$, A ₀ - A ₁₅ , DIEN, $\overline{\text{ADF}}$, RD ₀ - RD ₇ , $\overline{\text{RES}}$, $\overline{\text{DIV}}$
"L" Input Current	I_{IL}	—	—	-1	μA	
"H" Input Current	I_{IH}	25	—	100	μA	TEST1, TEST2
"L" Input Current	I_{IL}	—	—	-1	μA	

Output Characteristics

($V_{DD} = 5\text{V} \pm 5\%$, $T_a = -20$ to $+85^\circ\text{C}$)

Parameter	Symbol	Condition	Min.	Typ.	Max.	Unit	Applicable pin
"H" Output Current	I_{OH}	$V_{OH} = 2.8\text{V}$	-500	—	—	μA	LD ₀ - LD ₃ UD ₀ - UD ₃ MA ₀ - MA ₁₅ RA ₀ - RA ₃
"L" Output Current	I_{OL}	$V_{OL} = 0.4\text{V}$	2.4	—	—	mA	CH ϕ , CE ϕ , LIP, FRP FRMB, BUSY, CLP DB ₀ - DB ₇

Supply Current

($V_{DD} = 5V \pm 5\%$, $T_a = -20$ to $+85^\circ C$)

Parameter	Symbol	VDD	Condition	Min.	Typ.	Max.	Unit
Static Current	I_{DDs}	5	$f_{osc} = 0$ Hz, no load	—	—	50	μA
Dynamic Current	I_{DD}	5	$f_{osc} = 10$ MHz, no load	—	—	15	mA

Note: TEST 1 and TEST2 are open, and other inputs are either V_{DD} or GND.

Switching Characteristics

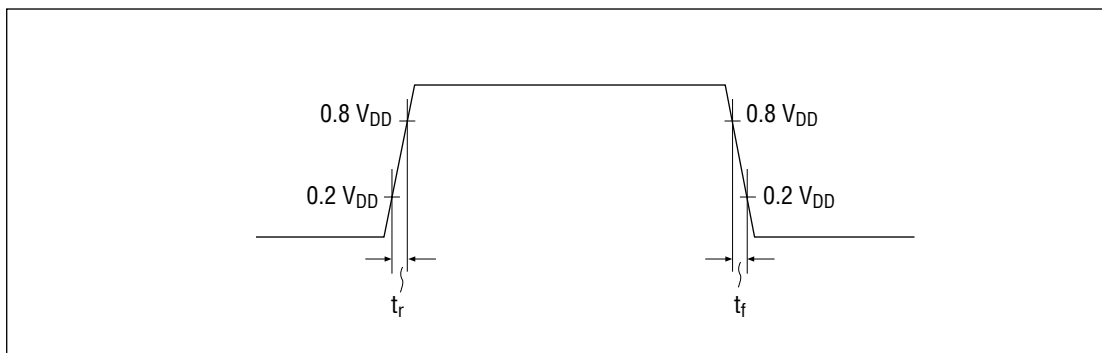

($V_{DD} = 5V \pm 5\%$, $T_a = -20$ to $+85^\circ C$)

Parameter	Symbol	Condition	Min.	Typ.	Max.	Unit	Applicable pin
Rise Time	t_r	$C_L = 60$ pF	—	—	100	ns	All output pins
Fall Time	t_f	$C_L = 60$ pF	—	—	100	ns	

Operating Frequency

($V_{DD} = 5V \pm 5\%$, $T_a = -20$ to $+85^\circ C$)

Parameter	Symbol	Condition	Min.	Typ.	Max.	Unit	Notes
Oscillating Frequency	f_{osc}	$\overline{DIV} = "L"$	—	—	11	MHz	Crystal oscillator
Basic Clock Frequency	f_s	$\overline{DIV} = "H"$	—	—	5.5	MHz	External clock

TIMING DIAGRAM

LCDC Control Signal Timing Characteristics

($C_L = 30\text{pF}$, $V_{DD} = 5\text{V} \pm 5\%$, $T_a = -20$ to $+85^\circ\text{C}$)

Parameter	Symbol	Min.	Typ.	Max.	Unit
Clock Cycle Time	t_{CP}	180	—	—	ns
Clock "H" Level Pulse Width	P_{WH}	80	—	—	ns
Clock "L" Level Pulse Width	P_{WL}	80	—	—	ns
Clock Rise/Fall Time	t_{cr}/t_{cf}	—	—	20	ns
Character Clock Delay Time	t_{CH}	—	—	200	ns
Memory Address Clock Delay Time	t_{MA}	—	—	100	ns
Memory Address Disable Delay Time	t_{AD1}	—	—	40	ns
Memory Address Enable Delay Time	t_{AD2}	—	—	40	ns
CPU Address Delay Time	t_{AD3}	—	—	100	ns
Refresh Address Delay Time	t_{AD4}	—	—	100	ns
Reset "H" Level Pulse Width	t_{RES}	1	—	—	μs
CPU Address Delay Time	t_{AD5}	—	—	100	ns

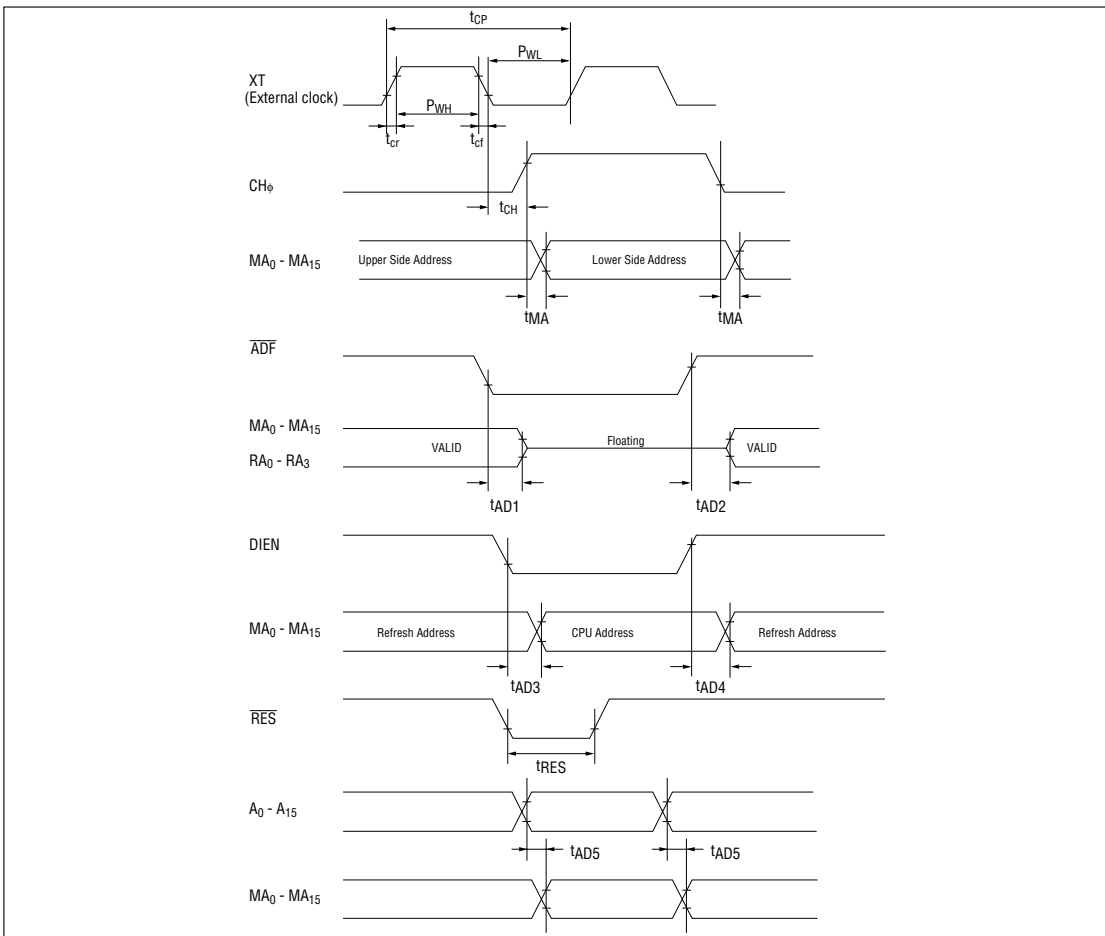

Bus Timing Characteristics

($C_L = 50\text{pF}$, $V_{DD} = 5\text{V} \pm 5\%$, $T_a = -20 \text{ to } +85^\circ\text{C}$)

Parameter	Symbol	Min.	Typ.	Max.	Unit
A_0, \overline{CS} Setup Time	t_{CS}	30	—	—	ns
$\overline{RD}, \overline{WR}$ Pulse Width	t_{CW}	200	—	—	ns
Address Hold Time	t_{AH}	10	—	—	ns
Data Setup Time	t_{DS}	60	—	—	ns
Data Hold Time	t_{DH}	20	—	—	ns
Output Disable Time	t_{OH}	0	—	40	ns
Access Time	t_{ACC}	—	—	200	ns

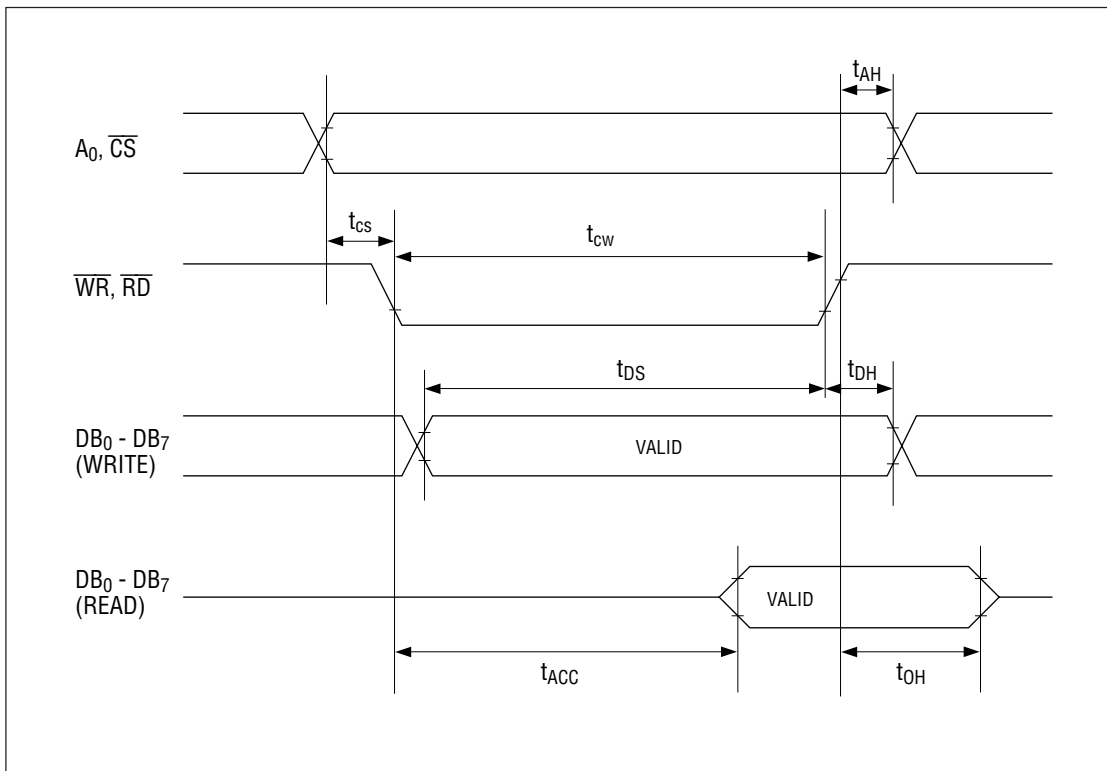

LCDC Driver Interface Timing Characteristics

($C_L = 30\text{pF}$, $V_{DD} = 5\text{V} \pm 5\%$, $T_a = -20$ to $+85^\circ\text{C}$)

Parameter	Symbol	Min.	Typ.	Max.	Unit
Data Delay Time	t_{DA}	—	—	100	ns
1 Character Cycle Time	$t_{CH\phi}$	730	—	—	ns
Latch Signal Delay Time	t_l	—	—	200	ns
Latch Signal "H" Time	t_{LIP}	1.46	—	—	μs
Chip Enable Clock Delay Time	t_{CE}	—	—	200	ns
Chip Enable Clock "H" Time	$t_{CE\phi}$	730	—	—	ns
Ready Signal Delay Time	t_B	—	—	200	ns
Ready Signal "H" Time	t_{BUSY}	5.11	—	—	μs
Frame Signal Delay Time	t_{FRP}	$2t_{CH\phi}$	—	$2t_{CH\phi} + 200$	ns
Alternating Frame Signal Delay Time	t_{FR}	—	—	200	ns

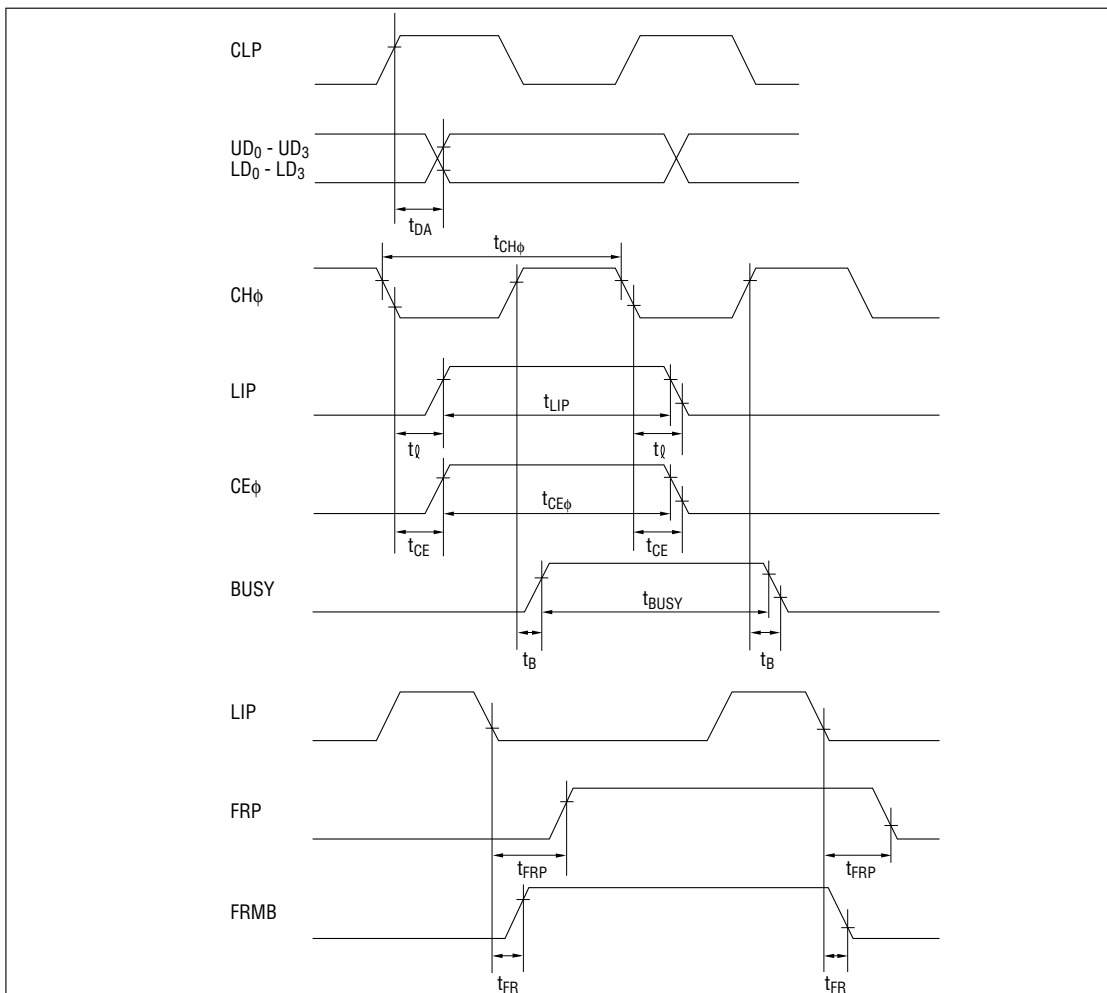

Timing for Fetching Pattern Data

($V_{DD} = 5V \pm 5\%$, $T_a = -20$ to $+85^\circ\text{C}$)

Parameter	Symbol	Min.	Typ.	Max.	Unit
Upper Side Data Setup Time	t_{UDS}	120	—	—	ns
Upper Side Data Hold Time	t_{UDH}	0	—	—	ns
Lower Side Data Setup Time	t_{LDS}	120	—	—	ns
Lower Side Data Hold Time	t_{LDH}	0	—	—	ns

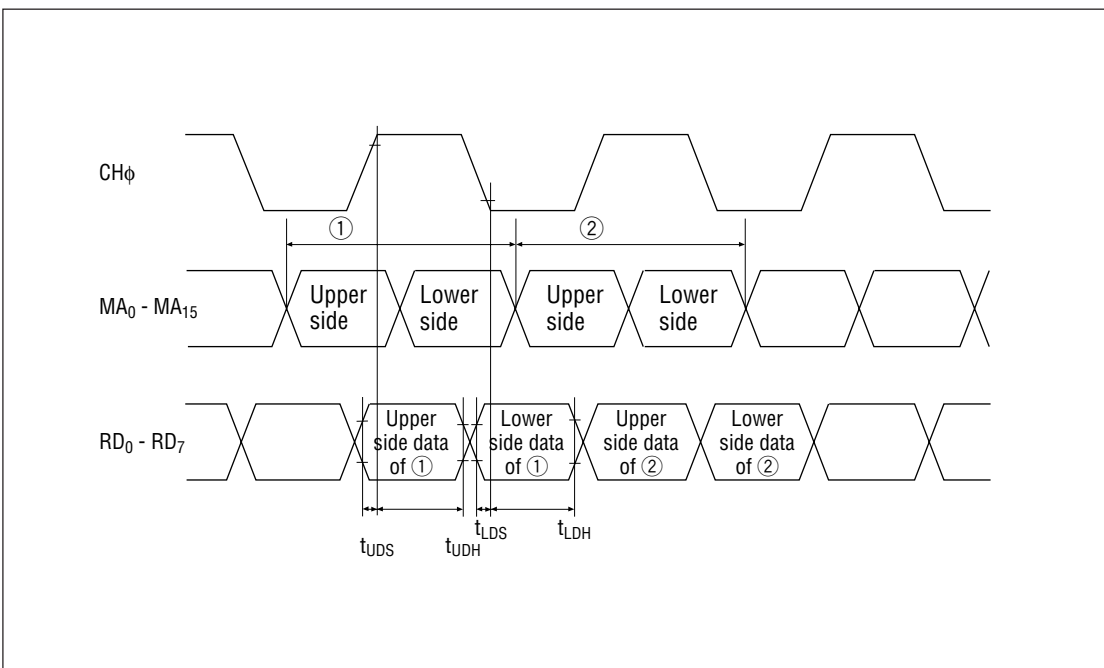

FUNCTIONAL DESCRIPTION

LCDC Internal Registers

The internal registers include one instruction register (IR) and nine data registers. (See Table 1.)

Table 1 MSM6255 Internal Registers

\overline{CS}	A ₀	Instruction register				Register	Register name	READ	WRITE	Data bit									
		3	2	1	0					7	6	5	4	3	2	1	0		
H	X	X	X	X	X	-	Invalid	-	-										
L	H	X	X	X	X	IR	Instruction register	○	○	X	X	X	X						
L	L	L	L	L	L	MOR	Mode control register	X	○	X									
L	L	L	L	L	H	PR	Character pitch register	○	○					X					
L	L	L	L	H	L	HNR	Horizontal character number register	○	○	X									
L	L	L	L	H	H	DVR	Duty number register	X	○										
L	L	L	H	L	L	CPR	Cursor form register	○	○										
L	L	L	H	L	H	SLR	Start address (lower) register	○	○										
L	L	L	H	H	L	SUR	Start address (upper) register	○	○										
L	L	L	H	H	H	CLR	Cursor address (lower) register	○	○										
L	L	H	L	L	L	CUR	Cursor address (upper) register	○	○										

Note: "L" is read if the data of the registers marked X is read.

- Instruction register
 The instruction register is a register for specifying the address of the data register which is accessed.
 This register is cleared when \overline{RES} input is "L".

- Mode control register
The mode control register is specified by writing "00_H" in the instruction register.

Register	A ₀	D ₇	D ₆	D ₅	D ₄	D ₃	D ₂	D ₁	D ₀
Instruction register	H	L	L	L	L	L	L	L	L
Mode control register	L	L	MODE DATA						

D ₆	D ₅	D ₄	D ₃	D ₂	D ₁	D ₀	Output mode	
H/L	H/L	H/L	H/L	L	L	L	1-bit serial	Character display
				H	L		2-bit parallel	
				X	H		4-bit parallel	
				X	H			
				L	L	H	1-bit serial	Graphics
				H	L		2-bit parallel	
				X	H		4-bit parallel	
				X	H			
Blink time	Cursor ON/OFF	Cursor blink	Display ON/OFF	2-bit parallel	4-bit parallel/ 1-bit serial			

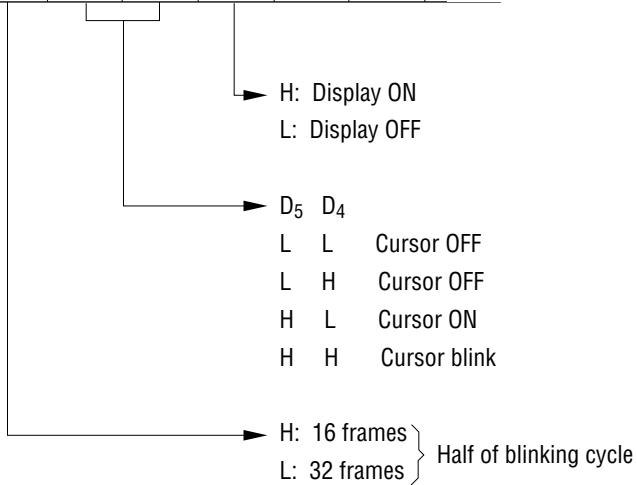

– Character pitch register

Register	A ₀	D ₇	D ₆	D ₅	D ₄	D ₃	D ₂	D ₁	D ₀
Instruction register	H	L	L	L	L	L	L	L	H
Character pitch register	L	(V _p - 1)				L	(H _p - 1)		

H_p represents the number of bits to be displayed among one byte display data sent from RAM. The value of H_p is the following five types.

H _p	D ₂	D ₁	D ₀
4	L	H	H
5	H	L	L
6	H	L	H
7	H	H	L
8	H	H	H

– Horizontal character number register

Register	A ₀	D ₇	D ₆	D ₅	D ₄	D ₃	D ₂	D ₁	D ₀	
Instruction register	H	L	L	L	L	L	L	H	L	
Character number register	L	L	(H _N - 1)							

Assuming that the total horizontal dot number of the display is n_H,

$$n_H = H_p \times H_N, \quad \text{where } H_N = 2 \text{ to } 128.$$

The maximum value of n_H = 8 × 128 = 128 bytes = 1,024 dots.

– Duty number register

Register	A ₀	D ₇	D ₆	D ₅	D ₄	D ₃	D ₂	D ₁	D ₀	
Instruction register	H	L	L	L	L	L	L	H	H	
Time division register	L	(N _x - 1)								

$$N_x = 2 \text{ to } 256$$

– Cursor form register

Register	A ₀	D ₇	D ₆	D ₅	D ₄	D ₃	D ₂	D ₁	D ₀
Instruction register	H	L	L	L	L	L	H	L	L
Cursor position register	L	(C _{pu} - 1)				(C _{pd} - 1)			

The cursor is displayed on the lines from C_{pu} to C_{pd} in the character display mode. The length of the cursor in the horizontal direction is equal to the character pitch in the horizontal direction, H_p. The cursor is not displayed in graphic mode. The relation between the cursor and V_p is as follows.

Font configuration of $H_p = 7$ and $V_p = 8$

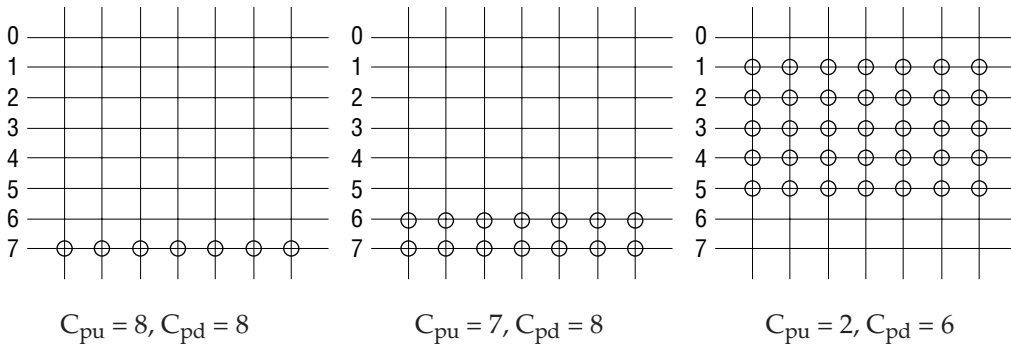

Notes: (1) Setting of $C_{pu}, C_{pd} > V_p$ is not available.
 (2) The cursor signal and pattern data are displayed subject to EX-OR.

– Start address (lower) register

Register	A ₀	D ₇	D ₆	D ₅	D ₄	D ₃	D ₂	D ₁	D ₀
Instruction register	H	L	L	L	L	L	H	L	H
Display start address register (lower byte)	L	Start address (lower)							

– Start address (upper) register

Register	A ₀	D ₇	D ₆	D ₅	D ₄	D ₃	D ₂	D ₁	D ₀
Instruction register	H	L	L	L	L	L	H	H	L
Display start address register (upper byte)	L	Start address (upper)							

The display start address shows an address of the RAM which stores data displayed at the left end and the most upper position. The start address is composed of upper and lower 8 bits (16 bits in total).

– Cursor address (lower) register

Register	A ₀	D ₇	D ₆	D ₅	D ₄	D ₃	D ₂	D ₁	D ₀
Instruction register	H	L	L	L	L	L	H	H	H
Cursor address register (lower byte)	L	Cursor address (lower)							

– Cursor address (upper) register

Register	A ₀	D ₇	D ₆	D ₅	D ₄	D ₃	D ₂	D ₁	D ₀
Instruction register	H	L	L	L	L	H	L	L	L
Cursor address register (upper byte)	L	Cursor address (upper)							

By this instruction, the value of the cursor address is written in the cursor address register. The

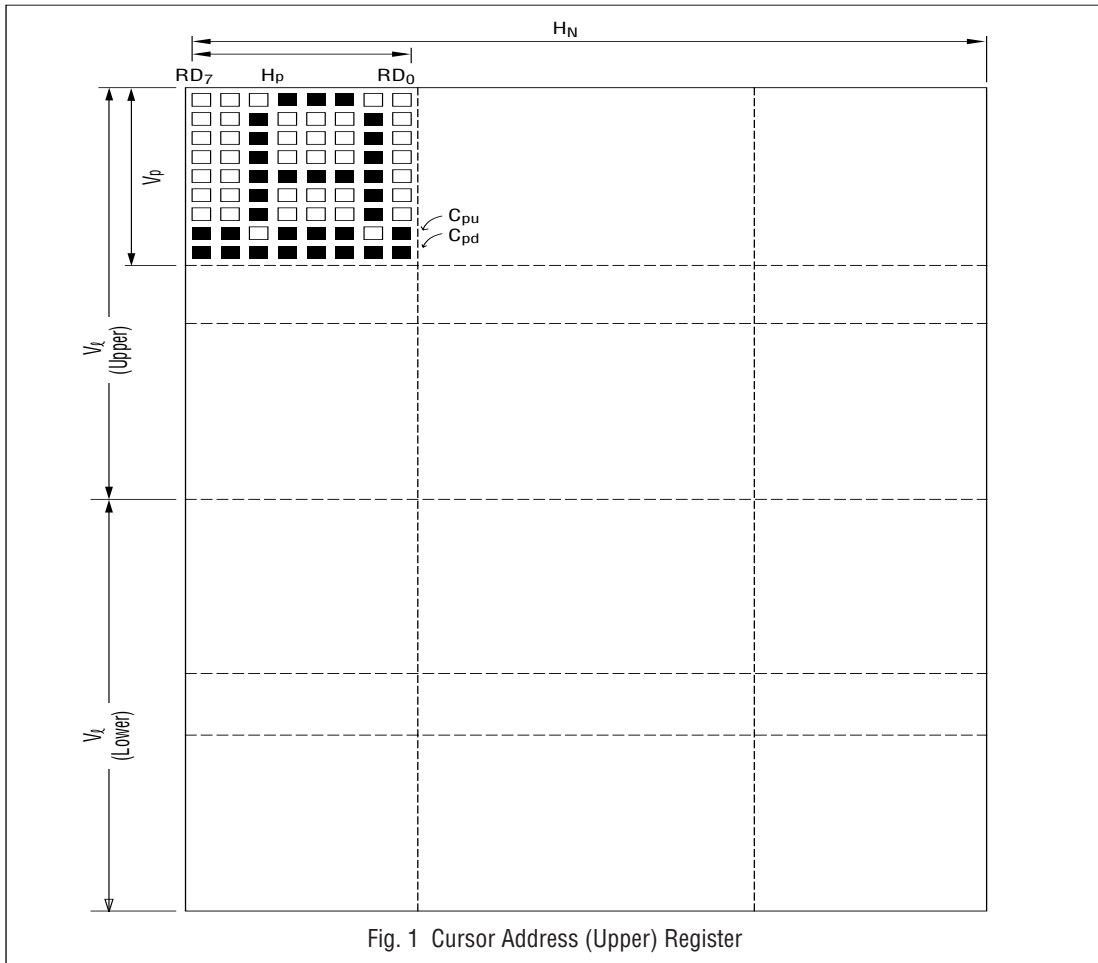

Fig. 1 Cursor Address (Upper) Register

Table 2 Legend

Symbol	Name	Meaning	Value
H_p	Horizontal pitch	Pitch of characters in horizontal direction	4 - 8 dots
V_p	Vertical pitch	Pitch of characters in vertical direction	1 - 16 dots
H_N	Number of characters in one line	Number of characters per line or number of words per line	2 - 128 characters
V_Q	Number of rows	Display duty	2 - 256
C_{pu}	Cursor start position	A position where the cursor starts display	Line 1 - 16
C_{pd}	Cursor end position	A position where the cursor stops display	Line 1 - 16

- Built-in Bus Averter
The bus averter which switches the address buses $A_0 - A_{15}$ of the CPU with the memory address buses of the refresh. The refresh memory addresses are output to $MA_0 - MA_{15}$ when the DIEN pin is set at high level and $A_0 - A_{15}$ are output to $MA_0 - MA_{15}$ when the DIEN pin is set at low level.
- External Clock Operation
An external clock enables the MSM6255 to operate when the \overline{DIV} pin is set at high level. Input the external clock to XT. (Leave \overline{XT} open.)
When the \overline{DIV} pin is set at low level, the IC enters the crystal oscillation mode.
- Address Output Floating
 $MA_0 - MA_{15}$ and $RA_0 - RA_3$ become high impedance when the \overline{ADF} pin is set at low level.
 $MA_0 - MA_{15}$ and $RA_0 - RA_3$ become normal impedance when the ADF pin is set at high level.
- Power Down Function
The chip select function becomes enabled for the segment driver by connecting the CE_ϕ pin to the ECLK input of the MSM5279. The power down function is valid only in 4-bit parallel output mode.
- Refresh Memory Address ($MA_0 - MA_{15}$) Operation
In the horizontal direction, MA_{xx} is counted up at the falling edge of CH_ϕ . Upper side is addressed while CH_ϕ is set at low level and lower side is addressed while CH_ϕ is set at high level.
 MA_{xx} is counted up even if it exceeds the number of horizontal display characters, but this does not affect the display since no data is being transferred at the time.
The period in which the data transfer is suspended corresponds to eight characters. When the period passes, one horizontal cycle is completed and the next cycle is commenced.
Memory address operation in the graphic mode is shown in Fig. 2 and that in the character mode is shown in Fig. 3.

Address configuration of display RAM

MSB														LSB	
MA ₁₅	MA ₁₄	MA ₁₃	MA ₁₂	MA ₁₁	MA ₁₀	MA ₉	MA ₈	MA ₇	MA ₆	MA ₅	MA ₄	MA ₃	MA ₂	MA ₁	MA ₀

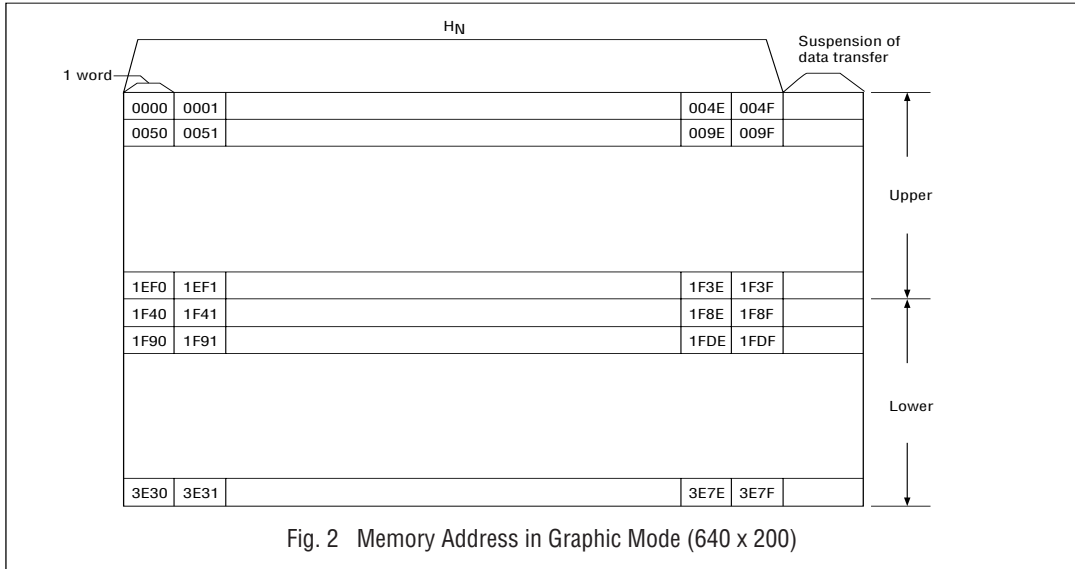

Note: "L" is output for RA₀ - RA₃.

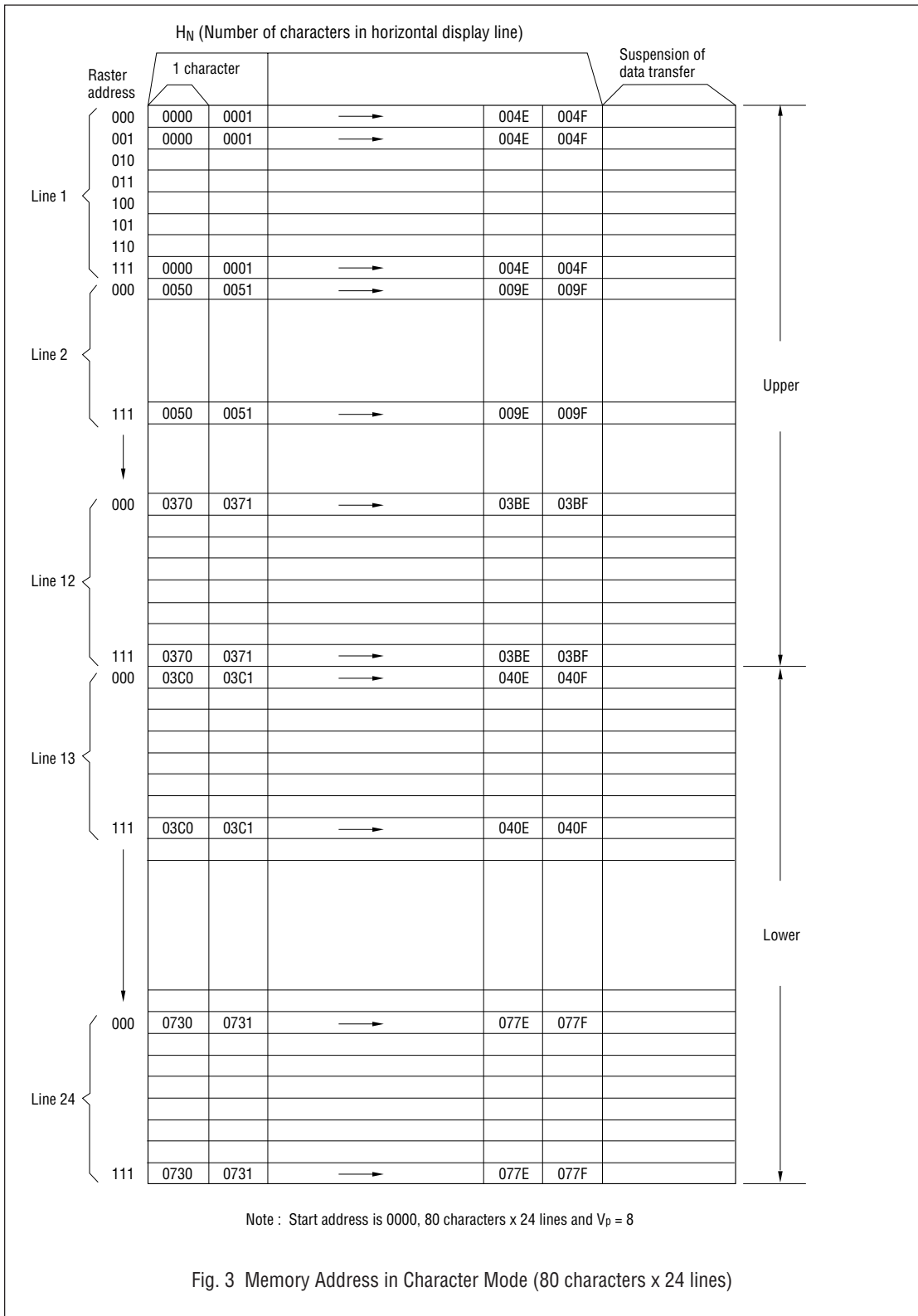

– Output Mode

Three kinds of modes, 1-bit serial, 2-bit parallel and 4-bit parallel, are available as output modes. Data flows of each mode are shown below.

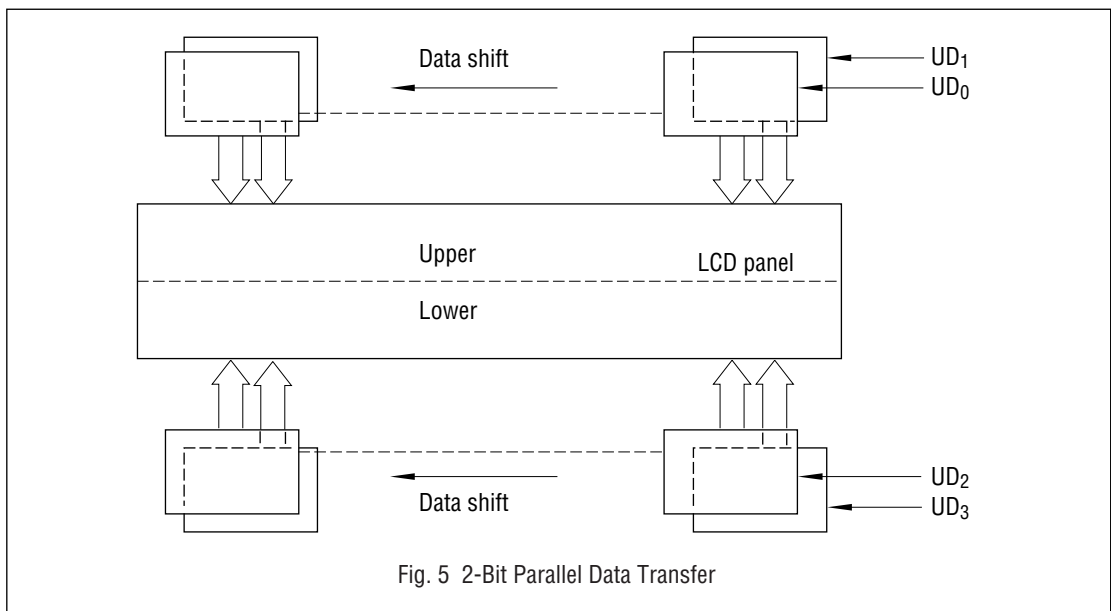
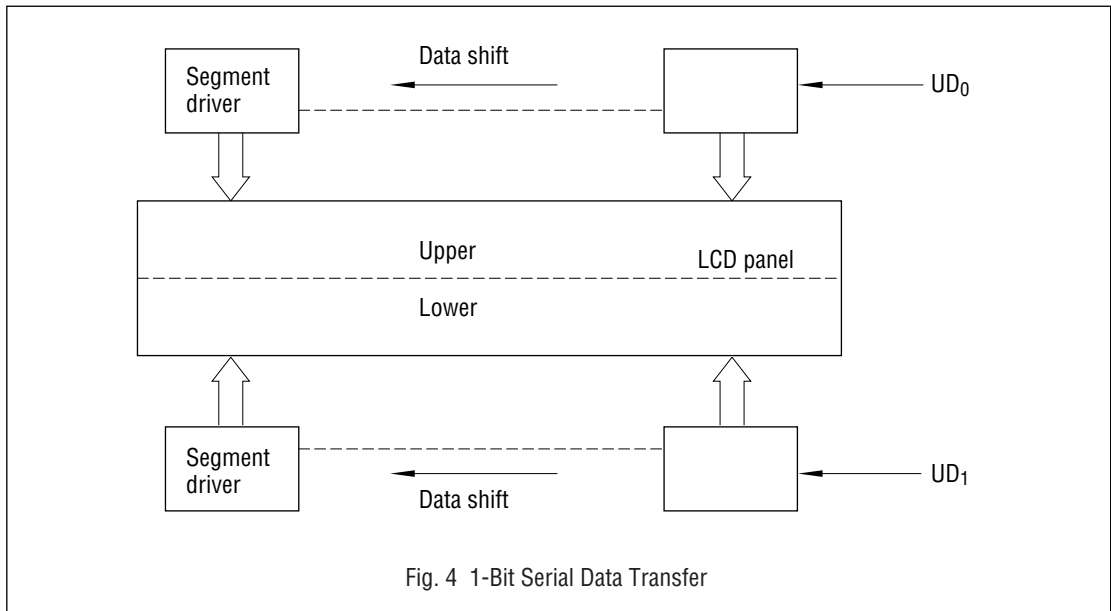

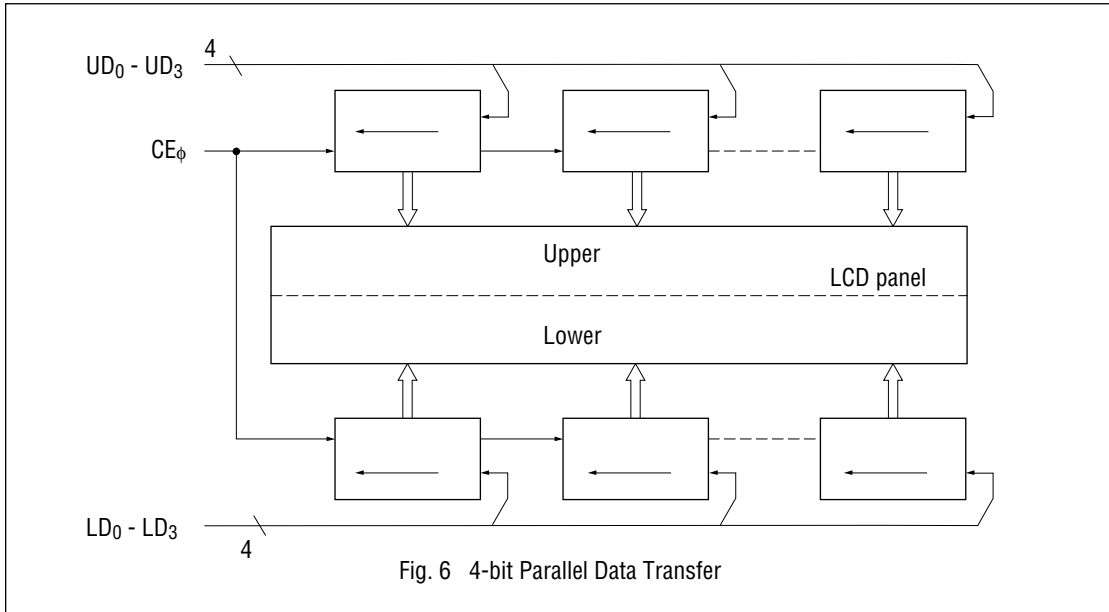

Time charts corresponding to data transfers shown in Fig. 4 - Fig. 6 are shown in Fig. 7 - Fig. 9. f_s , the dot clock, shown in Figs.7-9, is a signal inside the IC. For more information see "Relation between Reference Clock (f_s) and External Clock" on page 601.

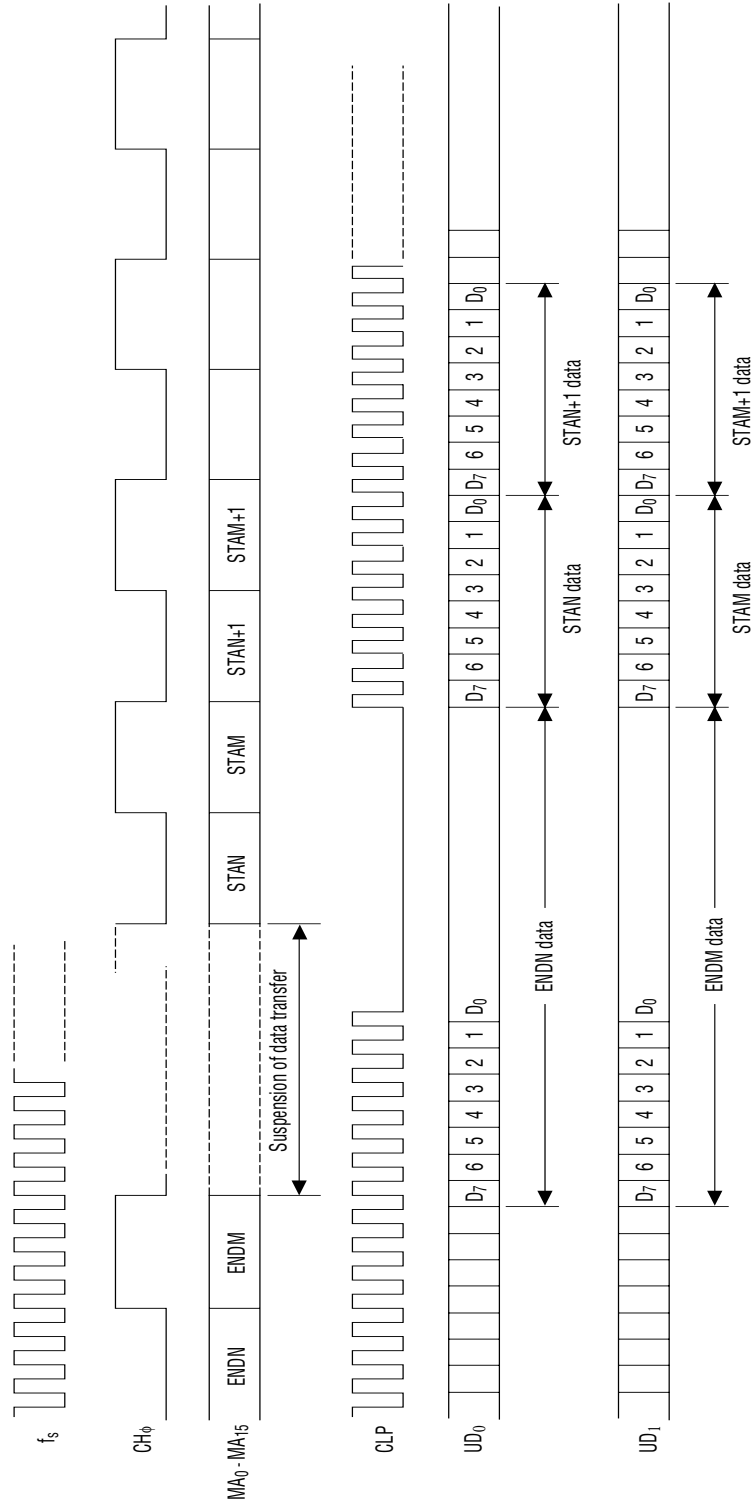

- STAN: First memory address of one horizontal line in the upper side
- STAM: First memory address of one horizontal line in the lower side
- ENDN: Last memory address of one horizontal line in the upper side
- ENDM: Last memory address of one horizontal line in the lower side

Fig. 7 1-bit Serial Data Transfer

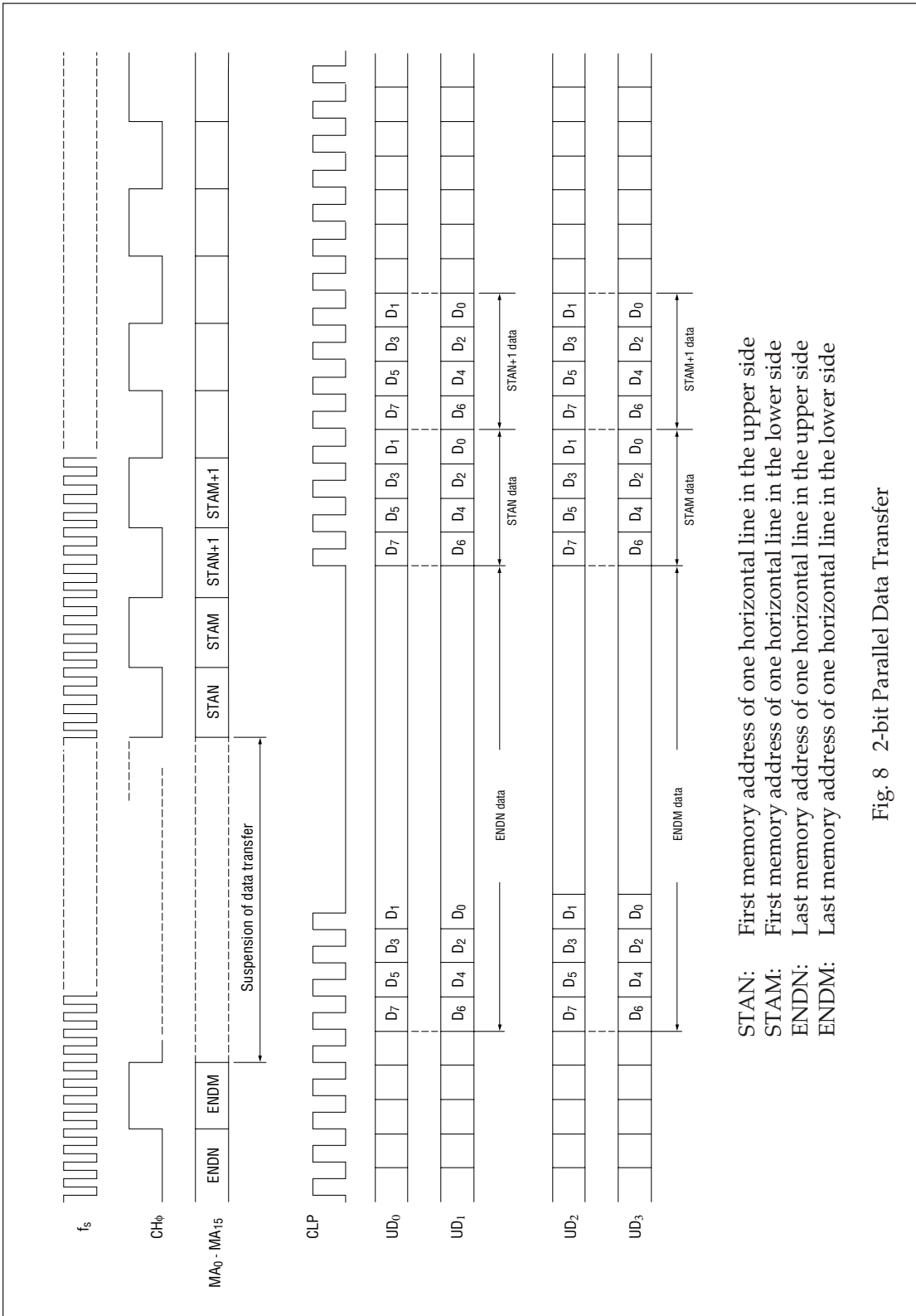

STAN: First memory address of one horizontal line in the upper side
 STAM: First memory address of one horizontal line in the lower side
 ENDN: Last memory address of one horizontal line in the upper side
 ENDM: Last memory address of one horizontal line in the lower side

Fig. 8 2-bit Parallel Data Transfer

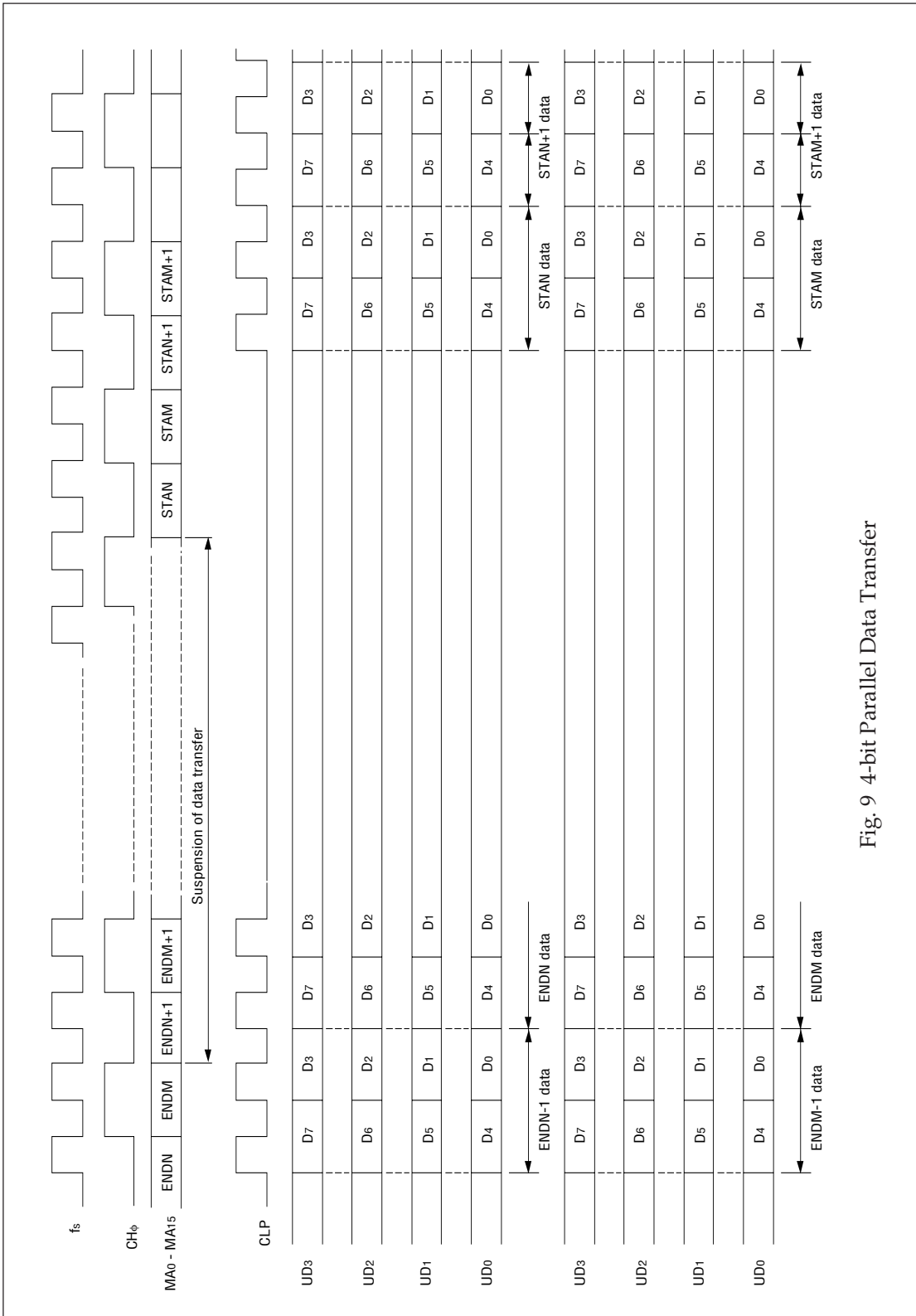

Fig. 9 4-bit Parallel Data Transfer

– Relation Between Duty and Number of Lines

Number of lines is determined by V_ℓ , number of lines in vertical direction(display duty).

Number of lines = $V_\ell \times 2$

Note: In the character display mode, number of lines should not be odd number.

– Calculation of Crystal Oscillation Frequency (f_{osc})

Table 3 Calculation Formula of f_{osc}

DIV	Output mode	Calculation formula of f_{osc}	Calculation example (MHz)
L	①	$FRP \times (H_N + 8) \times H_p \times V_\ell \times 2$	9.856
	②	$FRP \times (H_N + 8) \times V_\ell \times 4$	2.464
H	①	$FRP \times (H_N + 8) \times H_p \times V_\ell$	4.928
	②	$FRP \times (H_N + 8) \times V_\ell \times 2$	1.232

Note: (1) Table 3 shows a calculation example assuming that $FRP = 70$ Hz, $H_N = 80$, $H_p = 8$ and $V_\ell = 100$. However, the example of $H_p = 4$ to 7 in 4-bit parallel is not included.

(2) Output mode ① : $H_p = 4$ to 7 in 1-bit serial, 2-bit parallel and 4-bit parallel

Output mode ② : $H_p = 8$ in 4-bit parallel

– Calculation of Character Clock (CH_ϕ) Frequency

$$CH_\phi = FRP \times (H_N + 8) \times V_\ell$$

Example: Assuming $FRP = 70$ Hz, $H_N = 80$ and $V_r = 100$, $CH_\phi = 1.62$ (μ s)

– Calculation of Shift Clock (CLP) Frequency

Table 4 Calculation Formula of CLP

Output mode	Calculation formula of CLP	Calculation example (MHz)
1-bit serial	$RP \times (H_N + 8) \times H_p \times V_\ell$	4.928
2-bit parallel	$FRP \times (H_N + 8) \times H_p \times V_\ell \times 1/2$	2.464
4-bit parallel	$FRP \times (H_N + 8) \times H_p \times V_\ell \times 1/4$	1.232

Note: Table 4 shows a calculation example assuming that $FRP = 70$ Hz, $H_N = 80$, $H_p = 8$ and $V_\ell = 100$.

– Relation Between Reference Clock (f_s) and External Clock

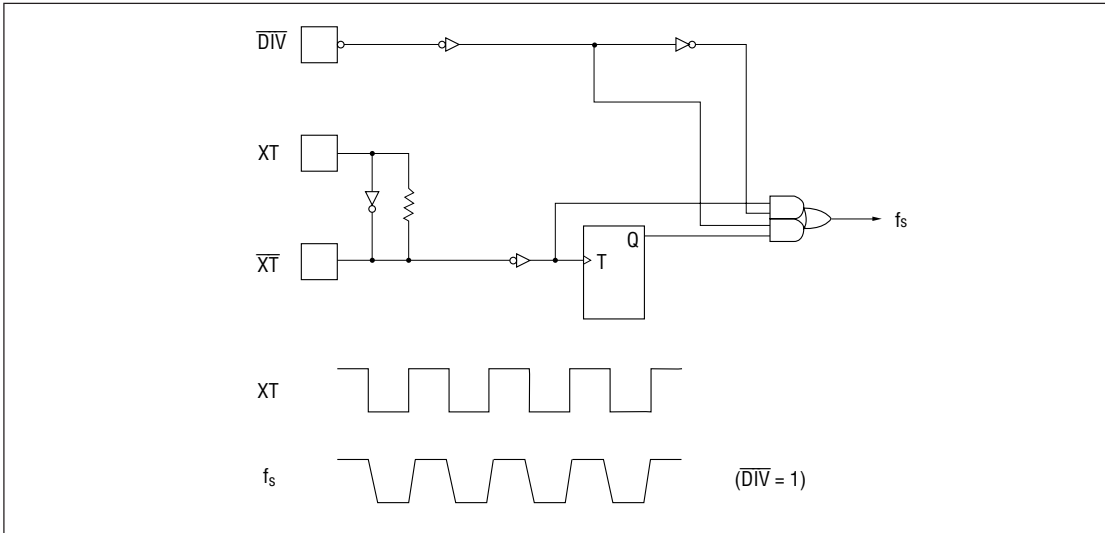

f_s functions as a dot clock in LCDC and the dot counter inside the IC is counted up at the trailing edge of f_s .

The dot counter operates as a N-ary counter on a basis of H_p and generates the character clocks (CH_ϕ).

(Refer to the time charts Fig. 7 - 9 and Fig. 14.)

– Access to the Display RAM

In writing/reading the data to/from the display RAM, DIEN should be low level. By setting DIEN signal at low level, the address from the CPU are output from MA0 - MA15, and this enables the access to the display RAM.

There are three methods of accessing display RAM from the CPU.

(1) Direct access from CPU

Display RAM is accessed directly from the CPU, irrespective of the condition of MSM6255 (refresh cycle or not).

In this method, the RAM address changes to the CPU address when the display is on the screen. So, frequent access to the RAM causes flickering on the screen.

(2) Access while BUSY signal is high

BUSY signal indicates the period when the data transfer stops, and BUSY signal is set high when the data transfer stops. The period when BUSY signal is high corresponds to that of seven characters'. If display RAM is accessed during this period (when BUSY is high), the display on the screen does not flicker.

Note: This method is effective when the size of screen is small. In the case of big size screen, 640 x 200 dots, 1character needs approx. 1.6ms. So, in this case, the period when BUSY is at high level is 11.2ms, which is impossible to write or read a lot of data.

(3) Synchronized access (only for operating the IC by external clock)

Refresh cycle and CPU cycle are alternately performed. So, there is not flickering on the screen and there is no need to sense the BUSY signal.

When using this method, however, some external circuitry is necessary. The timing chart

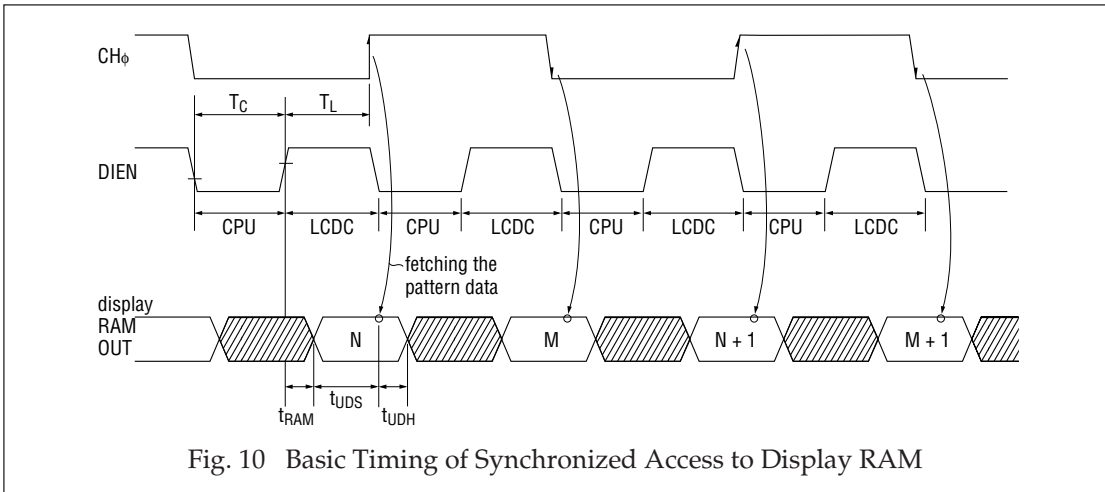

Legend

- T_C : Period when the address bus is occupied by CPU
- T_L : Period when the LCDC fetches the refreshed data
- t_{RAM} : Refresh address delay time + memory access time
- t_{UDS} : Upper side data set-up time
- t_{UDH} : Upper side data hold time

When DIEN is high, $MA_0 - MA_{15}$ output address to the upper side when CH_ϕ is low and to the lower side when CH_ϕ is high.

To perform synchronized access method, the timing between DIEN and CH_ϕ should be as described in Figure 10.

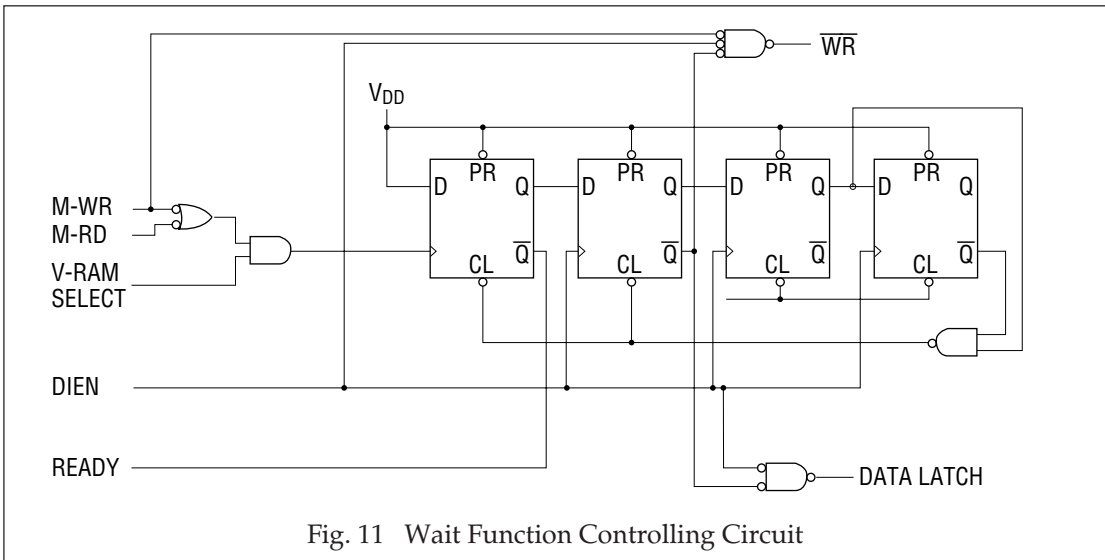

Display RAM must meet the following condition:

$$T_L > t_{RAM} + t_{UDS}$$

In writing data into the display RAM, LCDC should be synchronized so that the write pulse occurs during the period of T_C . In reading the pattern data from the CPU, the data of display RAM should be latched first.

- DIEN

DIEN has to be generated when the display RAM is accessed by Synchronized access method.

(1) When the LCD screen is not split into upper and lower ones

If, for example, an LCD panel with a total of 64 dots in vertical direction is displayed at 1/64 duty, either the upper side data or the lower side data becomes unnecessary, and then the CH ϕ signal can be used as a DIEN signal.

(2) When the LCD screen is split into upper and lower ones

If 4-bit parallel output mode is set and H_P=8, the timing diagram of the dot clock and the character clock is as shown below.

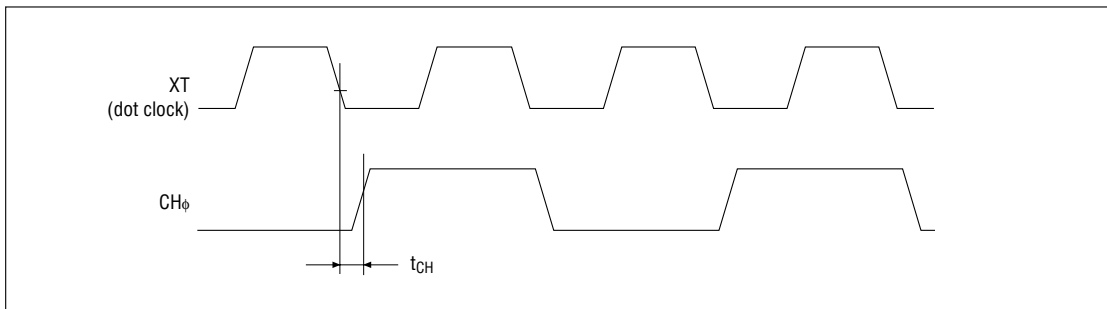

DIEN signal is generated by XT and CH ϕ .
DIEN signal generating circuit is shown below.

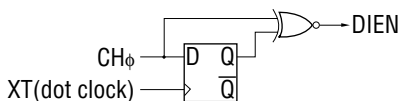

When H_P π 8 in the 1-bit serial, 2-bit parallel and 4-bit parallel mode, the relation between XT and CH ϕ should be referred to Figures 7 and 8.

- Scroll Δ Paging

Scroll Δ paging is enabled by setting the display start address to the scroll address register.

(1) Memory address of vertical scroll Δ paging

Figure 2 shows the memory address when the start address is 0000. When the start address is set at 0050, the display will be vertically shifted by +1.

By setting the starting address one by one, the screen will scroll vertically.

scroll Δ paging will be performed by setting the start address as 3E80.

(2) Memory address of horizontal scroll

When the starting address is set at 0001 in Figure 2, the display on the screen will be shifted by +1 byte horizontally. The data shown as 004F in Figure 2 corresponds to the memory data in the 2nd line shown as 0050.

APPLICATION CIRCUITS

Interface With CPU

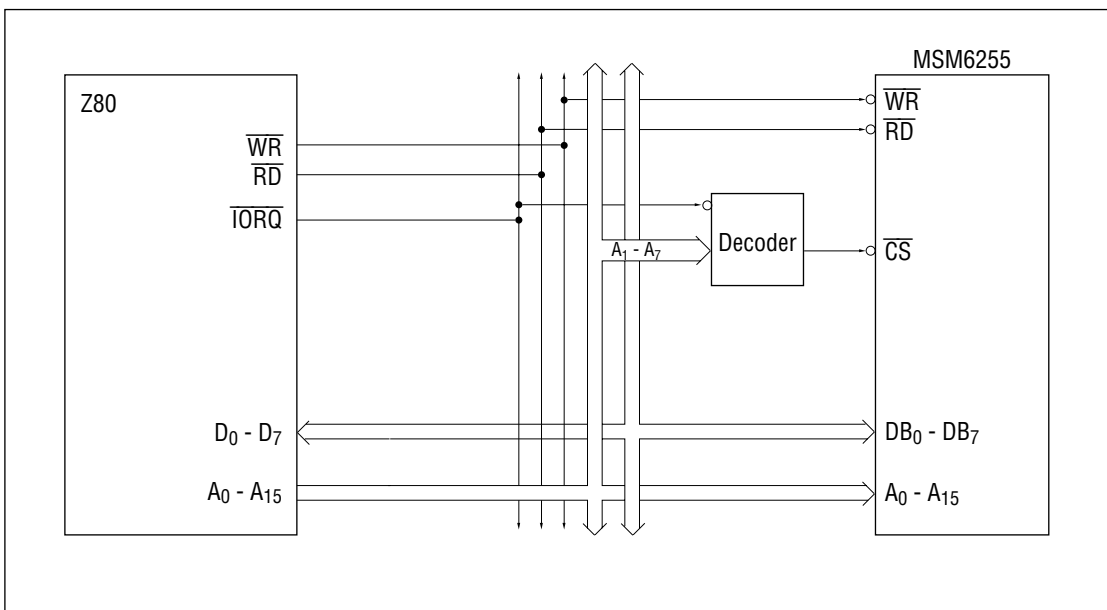
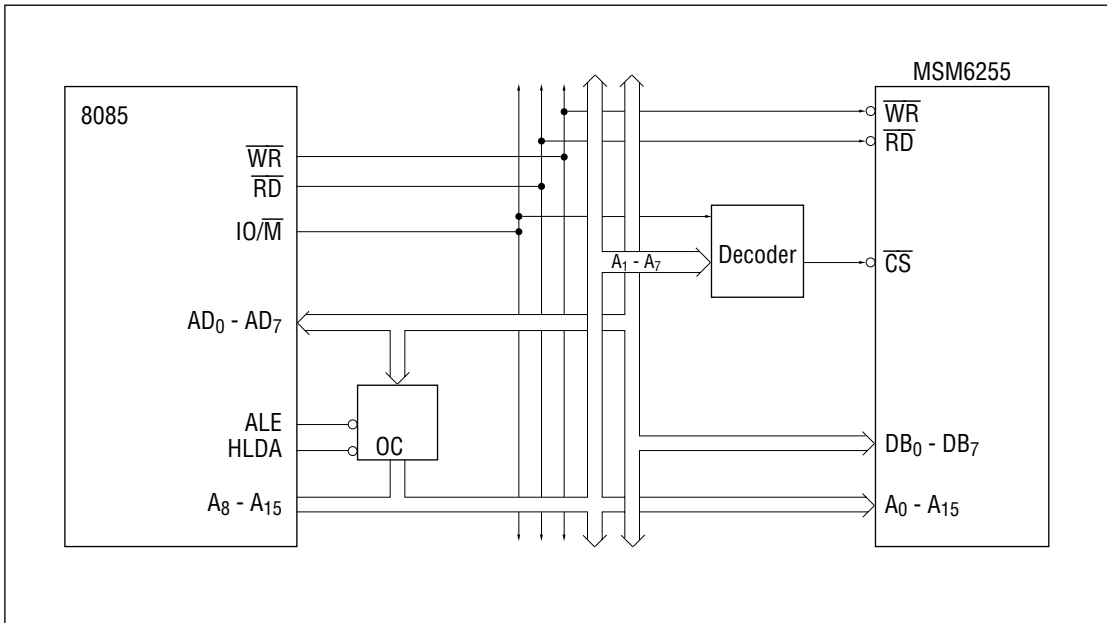

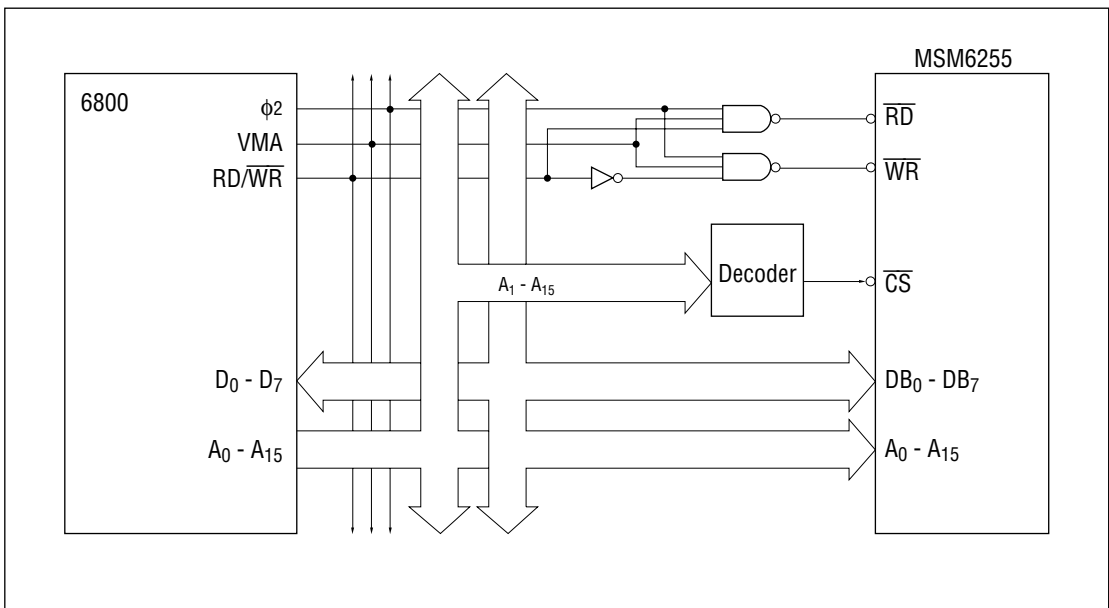
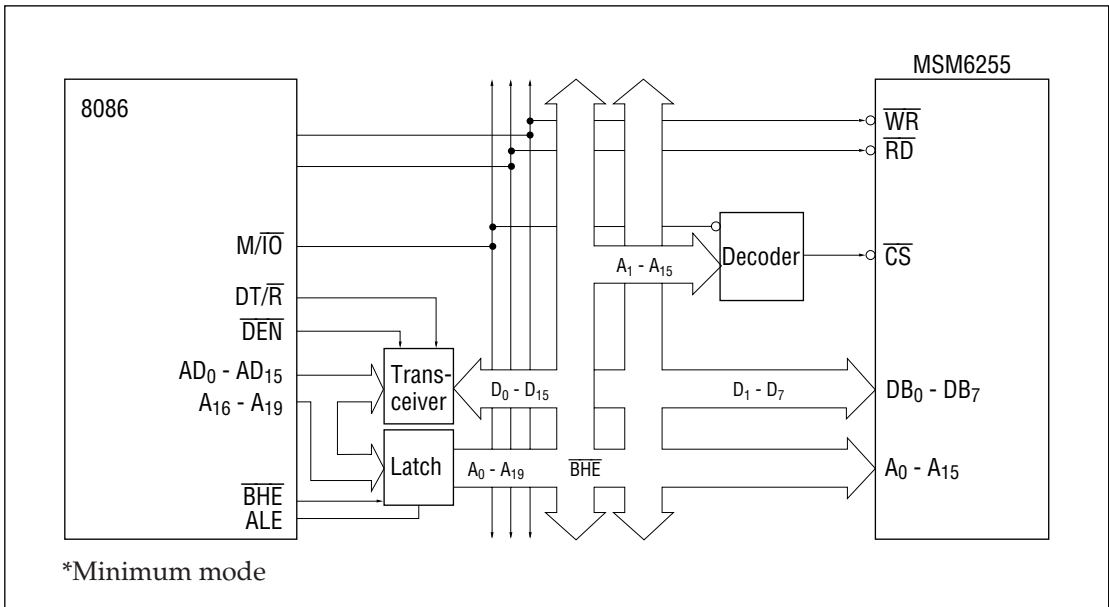

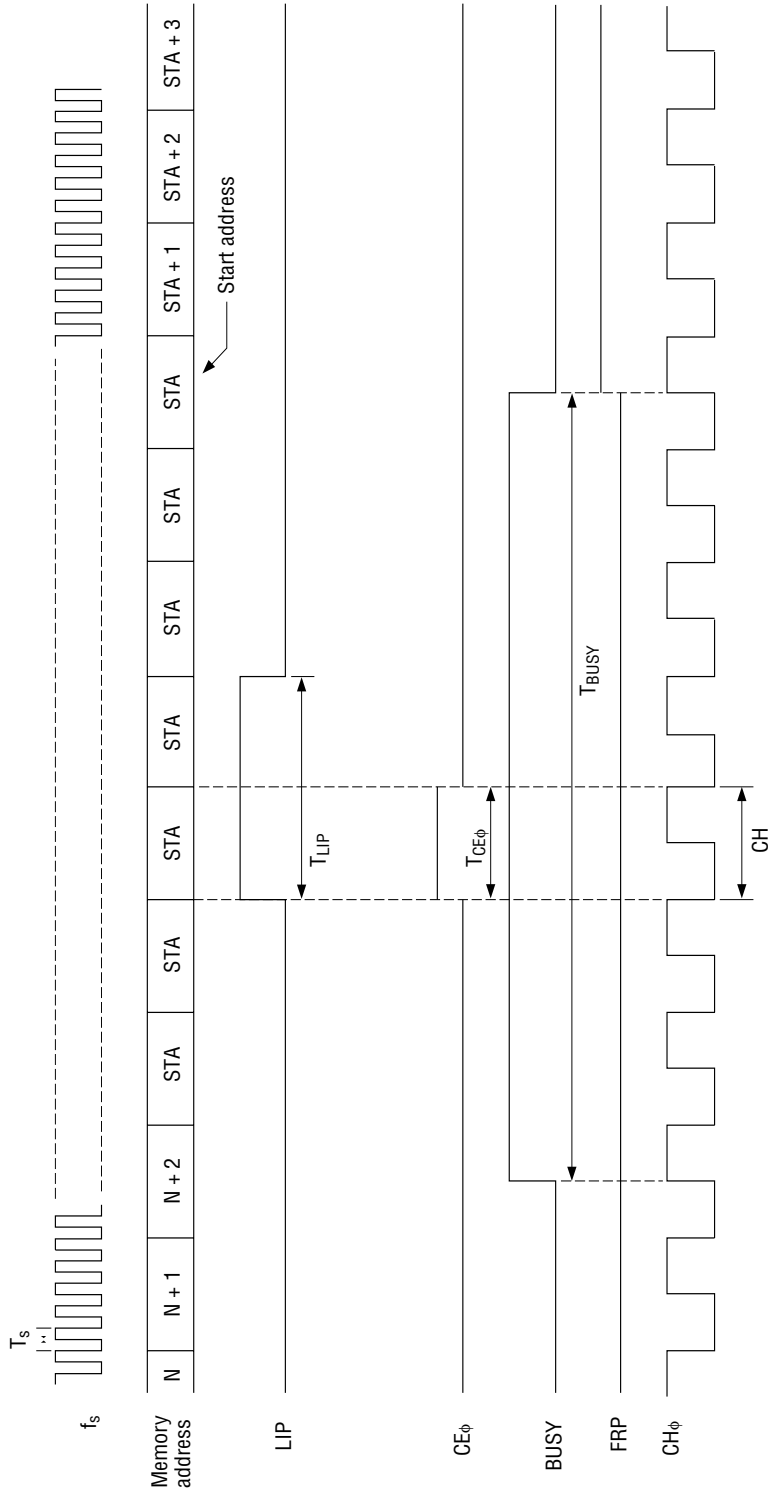

Fig. 14 Timing Chart During Suspension of Shift Clock

$$\left\{ \begin{array}{l} CH = T_s \times H_p \\ T_{LIP} = 2CH \\ T_{CE\phi} = CH \\ T_{BUSY} = 7CH \end{array} \right.$$

Condition : 4-bit parallel output mode
 $H_p = 5$

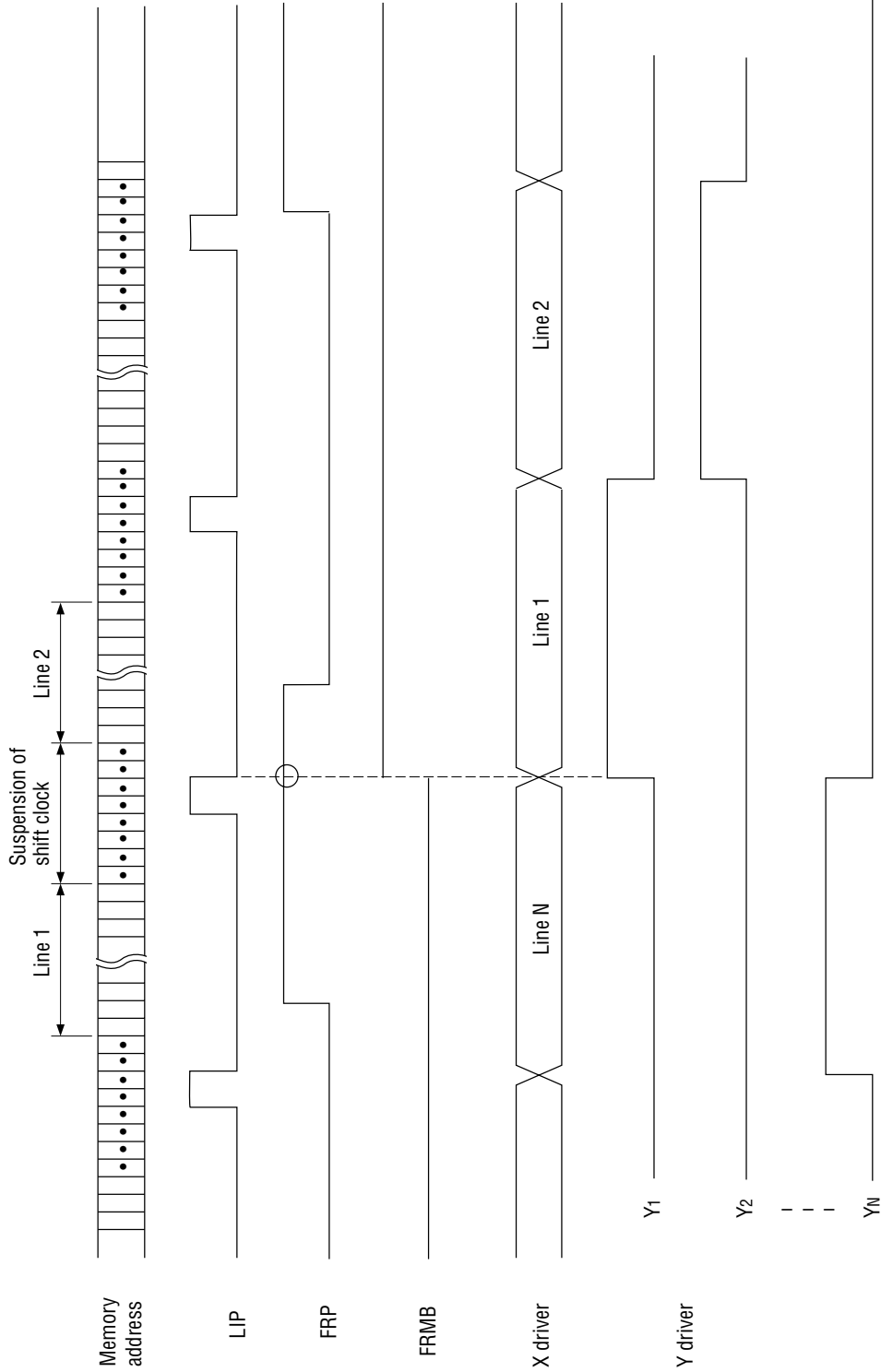
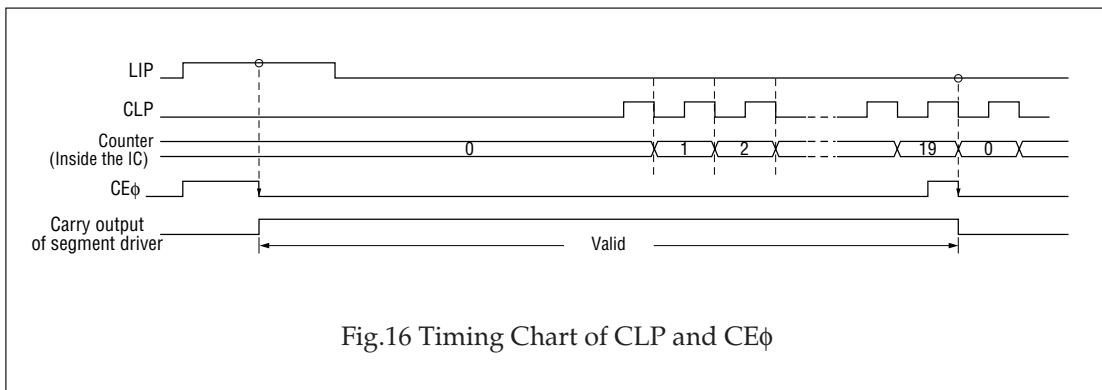

Fig. 15 Timing Chart of LIP, FRP and FRMB



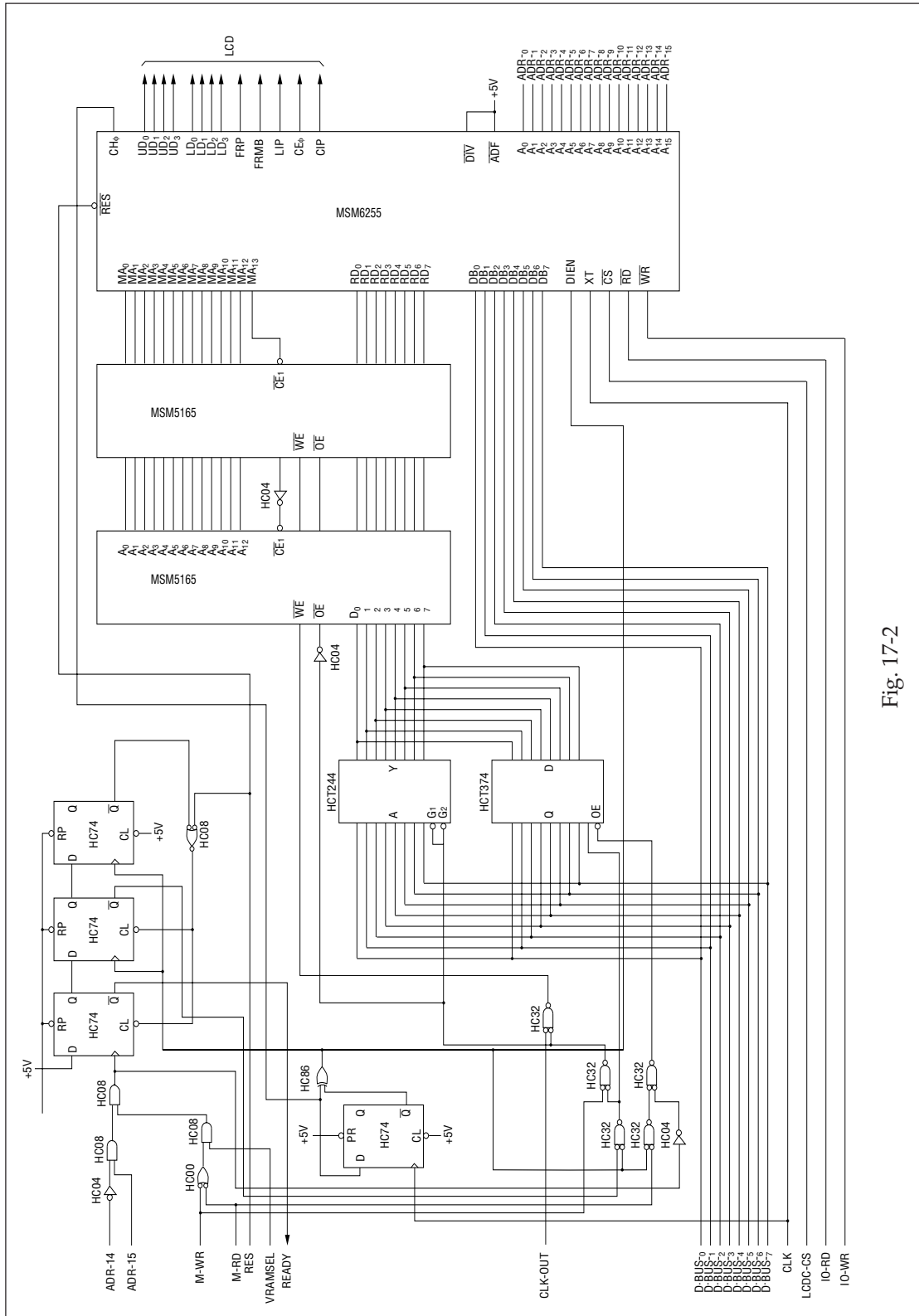

Fig. 17-2

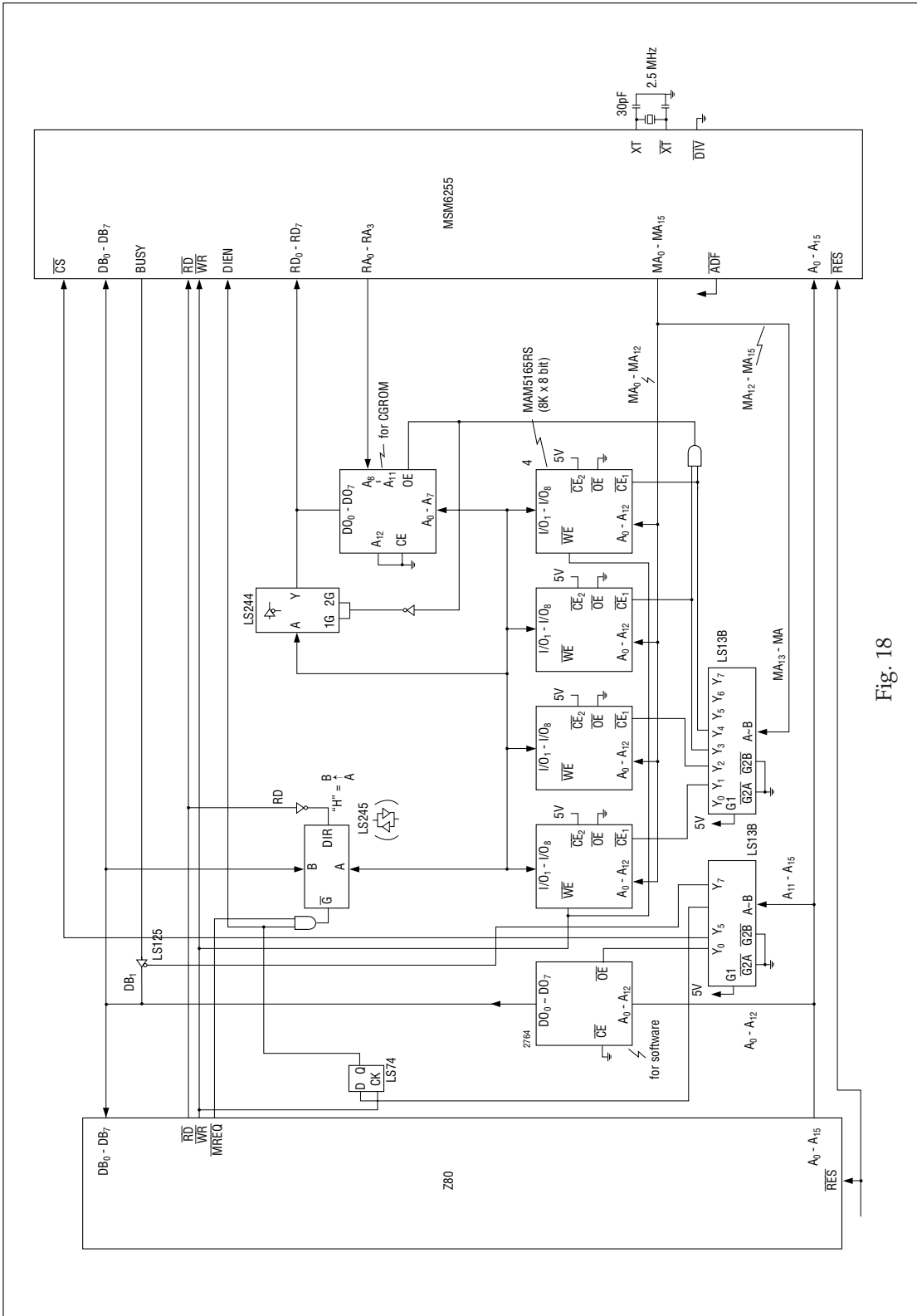
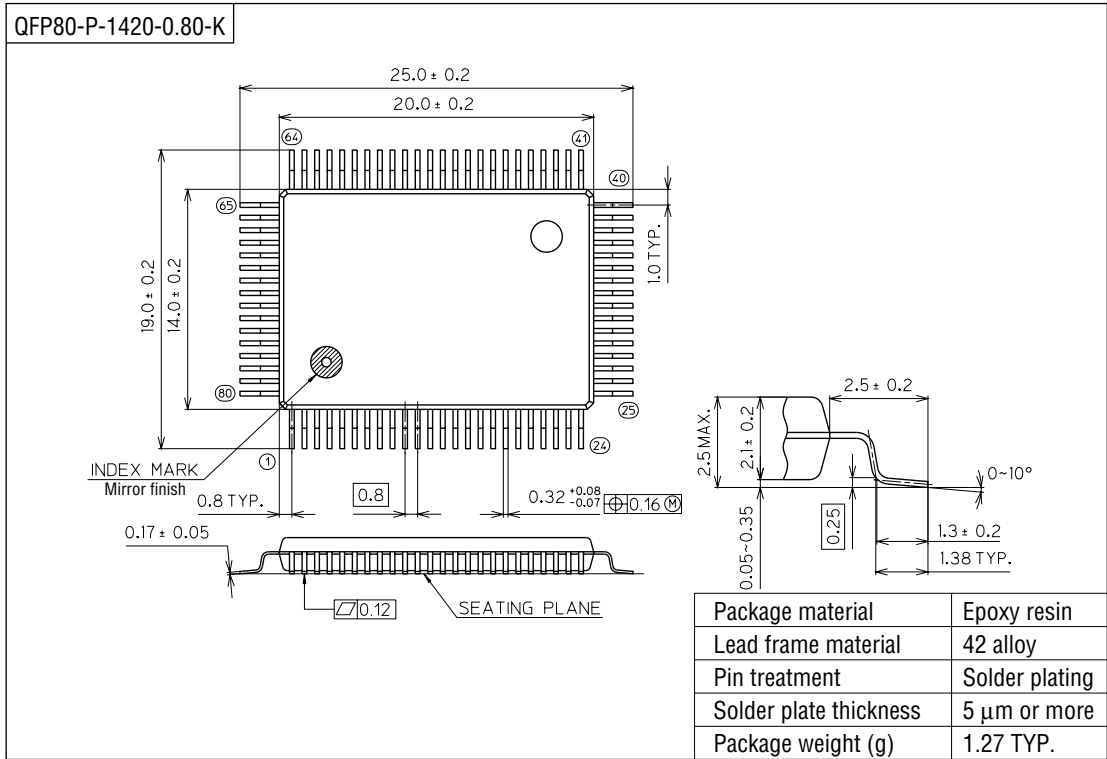

Fig. 18

PACKAGE DIMENSIONS

(Unit : mm)



Notes for Mounting the Surface Mount Type Package

The SOP, QFP, TSOP, SOJ, QFJ (PLCC), SHP and BGA are surface mount type packages, which are very susceptible to heat in reflow mounting and humidity absorbed in storage. Therefore, before you perform reflow mounting, contact Oki's responsible sales person for the product name, package name, pin number, package code and desired mounting conditions (reflow method, temperature and times).

(Unit : mm)

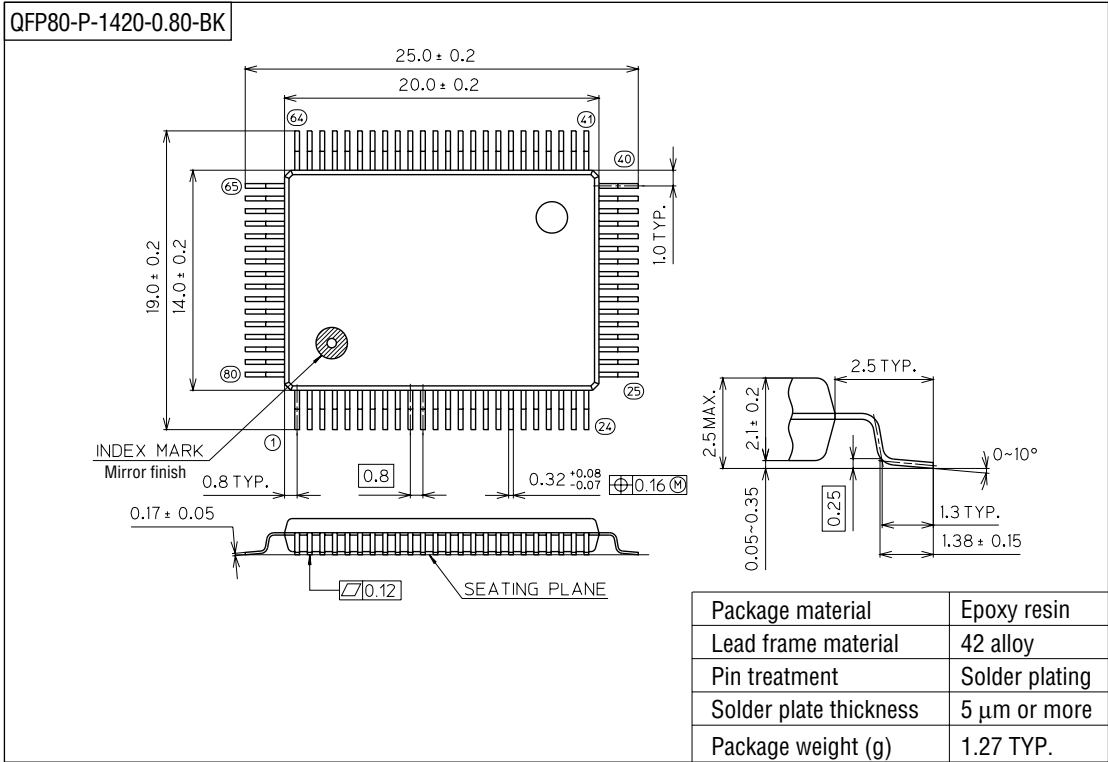

Notes for Mounting the Surface Mount Type Package

The SOP, QFP, TSOP, SOJ, QFJ (PLCC), SHP and BGA are surface mount type packages, which are very susceptible to heat in reflow mounting and humidity absorbed in storage. Therefore, before you perform reflow mounting, contact Oki's responsible sales person for the product name, package name, pin number, package code and desired mounting conditions (reflow method, temperature and times).