

# OKI Semiconductor

This version: Sep. 1998  
Previous version: Mar. 1996

## MSM6442

### Built-in LCD Driver 4-Bit Microcontroller

#### GENERAL DESCRIPTION

The MSM6442 is a 4-bit microcontroller with a built-in LCD controller/driver, developed to support control systems.

The MSM6442 is most suitable for various on-vehicle meters, watches, audio equipment, remote controllers, multifunctional telephones, and instrumentation units.

#### FEATURES

- ROM : 2048 words × 8 bits
  - RAM : 128 words × 4 bits
  - I/O port
    - Input-output port : 4 ports × 4 bits  
1 port × 2 bits
    - Input port : 1 port × 1 bit
  - LCD driver : 46 segments (static)  
: 92 segments (1/2 duty)
  - Stack (RAM) : 16 levels
  - Four interrupt sources (external, CLK, TBC, T/C)
  - Internal counter : 12-bit time base counter  
8-bit programmable timer/event counter
  - Crystal and ceramic oscillation
  - 76 instructions
  - Minimum instruction execution time : 952 ns @ 4.2 MHz
  - Operating range
    - Power supply voltage : 4.5 to 5.5 V (@ 4.2 MHz)  
3.0 to 6.0 V (@ 1 MHz)
    - Operating temperature : -40 to +85°C
  - Supply current (Typ.) : 6 mA (@ 5 V, 4.2 MHz)  
1 mA (@ 3 V, 1 MHz)
  - Power down function : Dependent on STOP instruction
  - Package options:
    - 80-pin plastic QFP (QFP80-P-1420-0.80-K): (Product name : MSM6442-xxGS-K)
    - 80-pin plastic QFP (QFP80-P-1420-0.80-BK): (Product name : MSM6442-xxGS-BK)
- xx indicates a code number.

BLOCK DIAGRAM

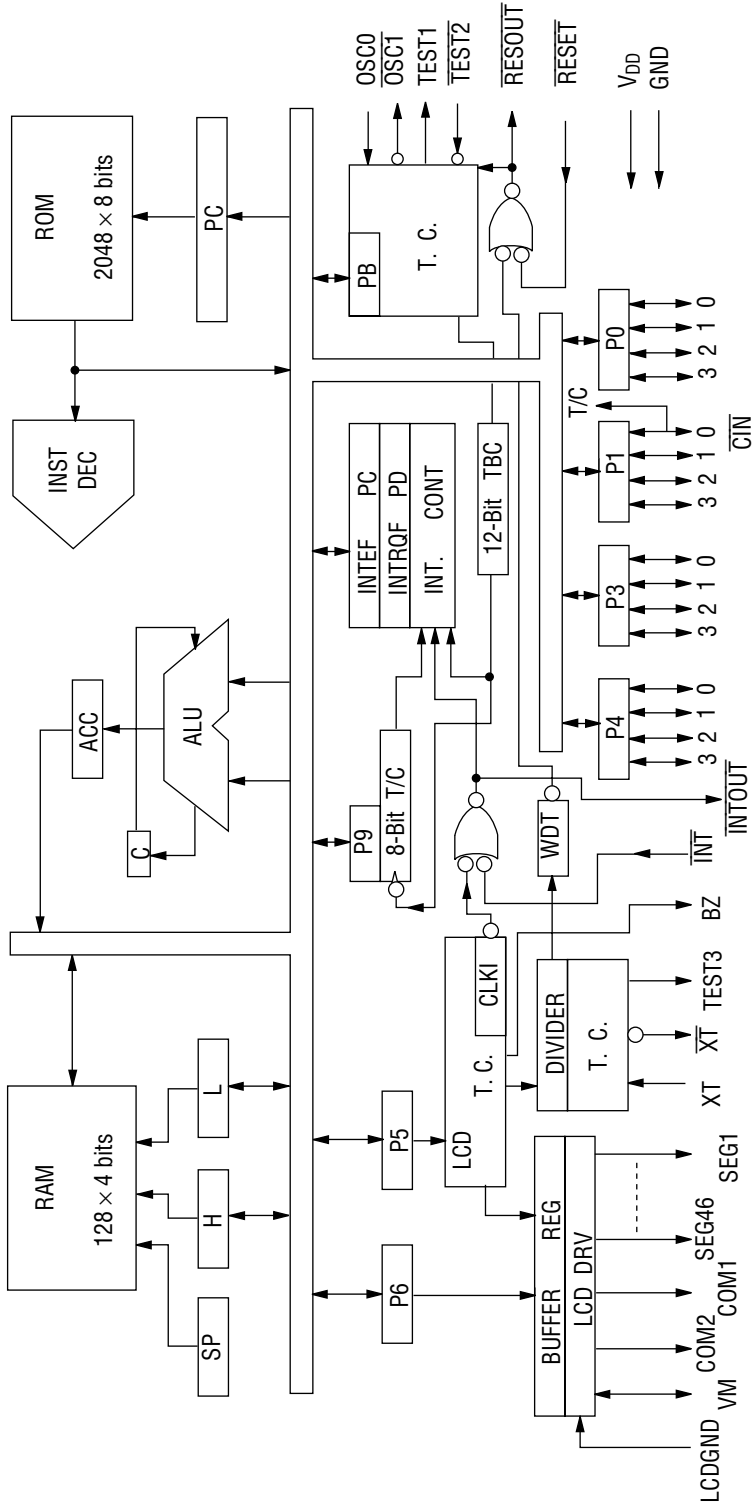

**PIN CONFIGURATION (TOP VIEW)**

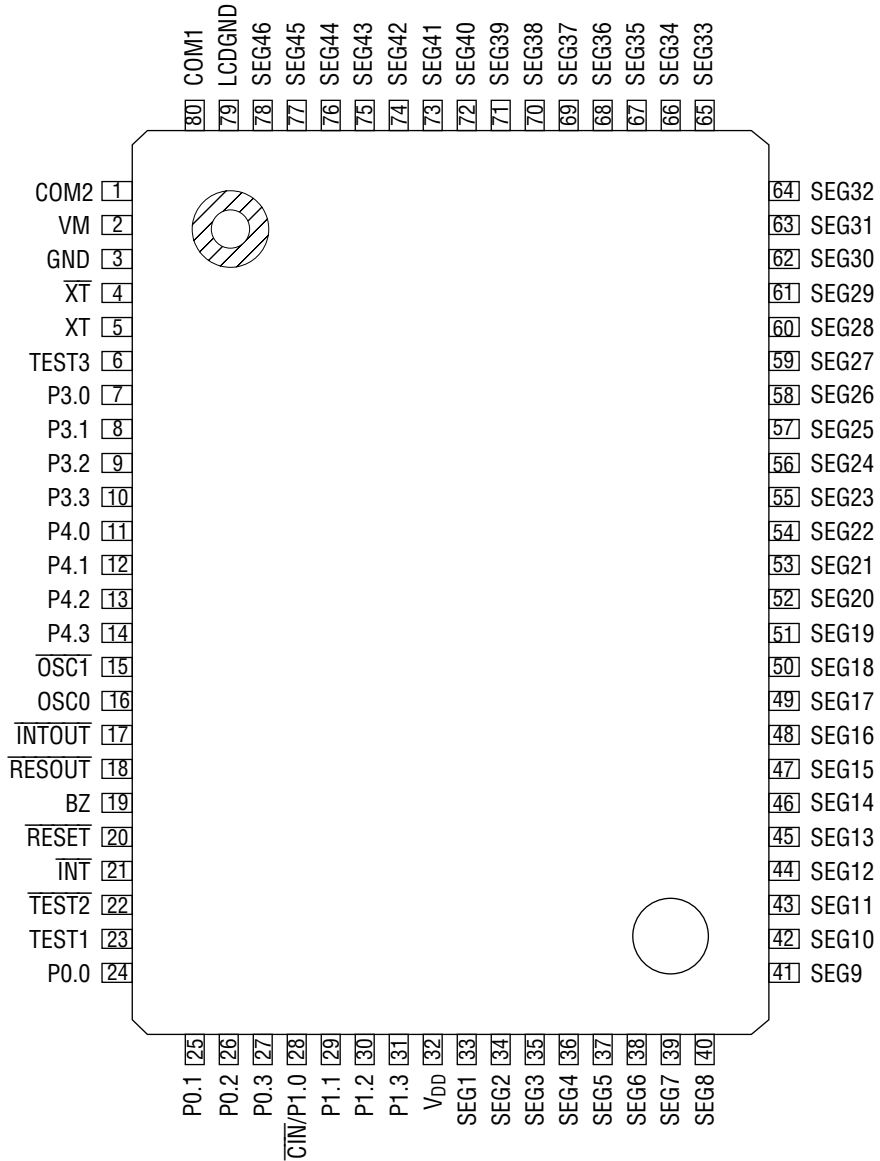

**80-Pin Plastic QFP**

## PIN DESCRIPTIONS

Pin	Symbol	Type	Description
24 to 27 28 to 31 7 to 10	P0.0 to P0.3 P1.0 to P1.3 P3.0 to P3.3	I/O	Pseudobidirectional configuration input-output ports (P1.0 is also used as count input $\overline{CIN}$ )
11 to 14	P4.0 to P4.3	I/O	Pseudobidirectional configuration input-output port
33 to 48	SEG1 to SEG16	0	LCD segment output (can be assigned to data output in 4 bits)
49 to 78	SEG17 to SEG46	0	LCD segment output
80	COM1	0	LCD common output 1
1	COM2	0	LCD common output 2
21	$\overline{INT}$	I	External interrupt input pin
17	$\overline{INTOUT}$	0	Interrupt request output pin
20	$\overline{RESET}$	I	Reset input pin
18	$\overline{RESOUT}$	0	Reset output pin
19	BZ	0	2048 Hz pulse output pin for buzzer
16	OSC0	I	Crystal or ceramic resonator connection (system clock)
15	$\overline{OSC1}$	0	
5	XT	I	32.768 kHz crystal oscillator connection (reference clock used for LCD control)
4	$\overline{XT}$	0	
23	$\overline{TEST1}$	—	Testing pin 1 (open)
22	$\overline{TEST2}$	—	Testing pin 2 (open) (connected to $V_{DD}$ )
6	$\overline{TEST3}$	—	Testing pin 3 (open)
32	$V_{DD}$	I	Power supply (5 V)
79	LCDGND	I	Negative power supply for LCD
2	VM	I/O	$(V_{DD}-LCDGND)/2$ supply voltage output or supply voltage input
3	GND	I	Power supply (0 V)

**ABSOLUTE MAXIMUM RATINGS**

Parameter	Symbol	Condition	Rating	Unit
Power Supply Voltage	$V_{DD}$	$T_a = 25^\circ\text{C}$	-0.3 to +7	V
Input Voltage	$V_I$		-0.3 to $V_{DD}$	V
Output Voltage	$V_O$		-0.3 to $V_{DD}$	V
LCD Voltage	LCDGND		$V_{DD} - 9$ to $V_{DD}$	V
Storage Temperature	$T_{STG}$	—	-55 to +150	$^\circ\text{C}$

**RECOMMENDED OPERATING CONDITIONS**

Parameter	Symbol	Condition	Range	Unit
Power Supply Voltage	$V_{DD}$	$f_{OSC} \leq 1 \text{ MHz}$	3 to 6	V
		$f_{OSC} \leq 4.2 \text{ MHz}$	4.5 to 5.5	V
LCD Voltage	LCDGND	*1	$V_{DD} - 8$ to 0	V
Data-Hold Voltage	$V_{DDH}$	Oscillation off	2 to 6	V
Operating Temperature	$T_{op}$	—	-40 to +85	$^\circ\text{C}$
LCD Clock Oscillation Frequency	$f_{XT}$	*2	32.768	kHz
Fan Out (I/O Port)	N	MOS load	15	—
		TTL load	1	—

\*1 A voltage of ( $V_{DD}$ -LCDGND) volts is applied to LCD.

\*2 Oscillation circuit for LCD clock (XT,  $\overline{XT}$  pins) is for crystal oscillation only.

**ELECTRICAL CHARACTERISTICS**

**DC Characteristics**

( $V_{DD} = 5\text{ V} \pm 10\%$ ,  $\text{LCDGND} = 0\text{ V}$ ,  $T_a = -40\text{ to }+85^\circ\text{C}$ )

Parameter	Applied pin	Symbol	Condition	Min.	Typ.	Max.	Unit
"H" Input Voltage	$\overline{\text{INT}}$ *1	$V_{IH}$	—	2.4	—	$V_{DD}$	V
	*3		—	3.6	—	$V_{DD}$	V
"L" Input Voltage	*1, *4	$V_{IL}$	—	0	—	0.8	V
"H" Output Voltage	$\overline{\text{OSC1}}$ *1	$V_{OH}$	$I_O = -15\ \mu\text{A}$	4.2	—	—	V
	*2		$I_O = -400\ \mu\text{A}$	2.4	—	—	V
	SEG1 to SEG46		$I_O = -10\ \mu\text{A}$	$V_{DD}-0.2$	—	—	V
	COM1, COM2		$I_O = -50\ \mu\text{A}$	$V_{DD}-0.2$	—	—	V
"L" Output Voltage	*1, *2	$V_{OL}$	$I_O = 1.6\ \text{mA}$	—	—	0.4	V
	$\overline{\text{OSC1}}$		$I_O = 15\ \mu\text{A}$	—	—	0.4	V
	SEG1 to SEG46		$I_O = 10\ \mu\text{A}$	—	—	0.2	V
	COM1, COM2		$I_O = 50\ \mu\text{A}$	—	—	0.2	V
"M" Output Voltage	COM1, COM2	$V_{OM}$	$I_O = \pm 0.5\ \mu\text{A}$	$V_{DD}/2 - 0.2$	—	$V_{DD}/2 + 0.2$	V
"H" Input Current	OSC0	$I_{IH}$	$V_I = V_{DD}$	—	—	15	$\mu\text{A}$
	XT			—	—	7	$\mu\text{A}$
	$\overline{\text{INT}}, \overline{\text{RESET}}$			—	—	1	$\mu\text{A}$
"L" Input Current	OSC0	$I_{IL}$	$V_I = 0\ \text{V}$	—	—	-15	$\mu\text{A}$
	XT			—	—	7	$\mu\text{A}$
	$\overline{\text{INT}}, \overline{\text{RESET}}$			—	—	-30	$\mu\text{A}$
"H" Output Current	*1	$I_{OH}$	$V_O = 2.4\ \text{V}$	-0.1	—	—	mA
			$V_O = 0.4\ \text{V}$	—	—	-1.2	mA
Power Supply Current (In Stop Mode) (32.768 kHz, Without Crystal Oscillator)		$I_{DDS}$	$V_{DD} = 2\ \text{V}, T_a = 25^\circ\text{C}$ No load Display off XT pin is fixed to "L"	—	0.2	10	$\mu\text{A}$
			No load Display off XT pin is fixed to "L"	—	1	100	$\mu\text{A}$
Power Supply Current (In Stop Mode)		$I_{DDL}$	No load Display off In stop mode $f_{XT} = 32.768\ \text{kHz}$	—	100	200	$\mu\text{A}$
Power Supply Current		$I_{DD}$	No load Display off $f_{OSC} = 4.2\ \text{MHz}$ $f_{XT} = 32.768\ \text{kHz}$	—	6	12	mA

- \*1 Applied to P0, P1, P3, and P4.
- \*2 Applied to  $\overline{\text{INTOUT}}, \overline{\text{RESOUT}}$ , and BZ.
- \*3 Applied to OSC0, XT, and  $\overline{\text{RESET}}$ .
- \*4 Applied to OSC0, XT,  $\overline{\text{INT}}$ , and  $\overline{\text{RESET}}$ .

Note: "M" output voltage is an intermediate voltage that is output to the COMMON pins

## AC Characteristics

(V<sub>DD</sub> = 5 V ±10%, Ta = -40 to +85°C)

Parameter	Symbol	Condition	Min.	Typ.	Max.	Unit
Clock (OSC0) Pulse Width	t <sub>φW</sub>	—	119	—	—	ns
Cycle Time	t <sub>CY</sub>	—	952	—	—	ns
Input Data Setup Time	t <sub>DS</sub>	—	120	—	—	ns
Input Data Hold Time	t <sub>DH</sub>	*1	120	—	—	ns
INT Input Data Pulse Width	t <sub>DW1</sub>	—	120	—	—	ns
CT Clock Pulse Width	t <sub>DW2</sub>	—	2/8 t <sub>CY</sub> + 120	—	—	ns
Data Delay Time	t <sub>DR</sub>	C <sub>L</sub> = 15 pF	—	—	300	ns
Reset Input Pulse Width	t <sub>WRS</sub>	*2	2 t <sub>CY</sub>	—	—	ns

\*1 To release power down by inputting an "L" level into  $\overline{\text{INT}}$  pin, the pulse width should be longer than the time for the oscillation stabilization at OSC0.

\*2 The condition of stable oscillation. To release power down by reset, the pulse width should be longer than the time for oscillation stabilization at OSC0.

Timing Diagrams

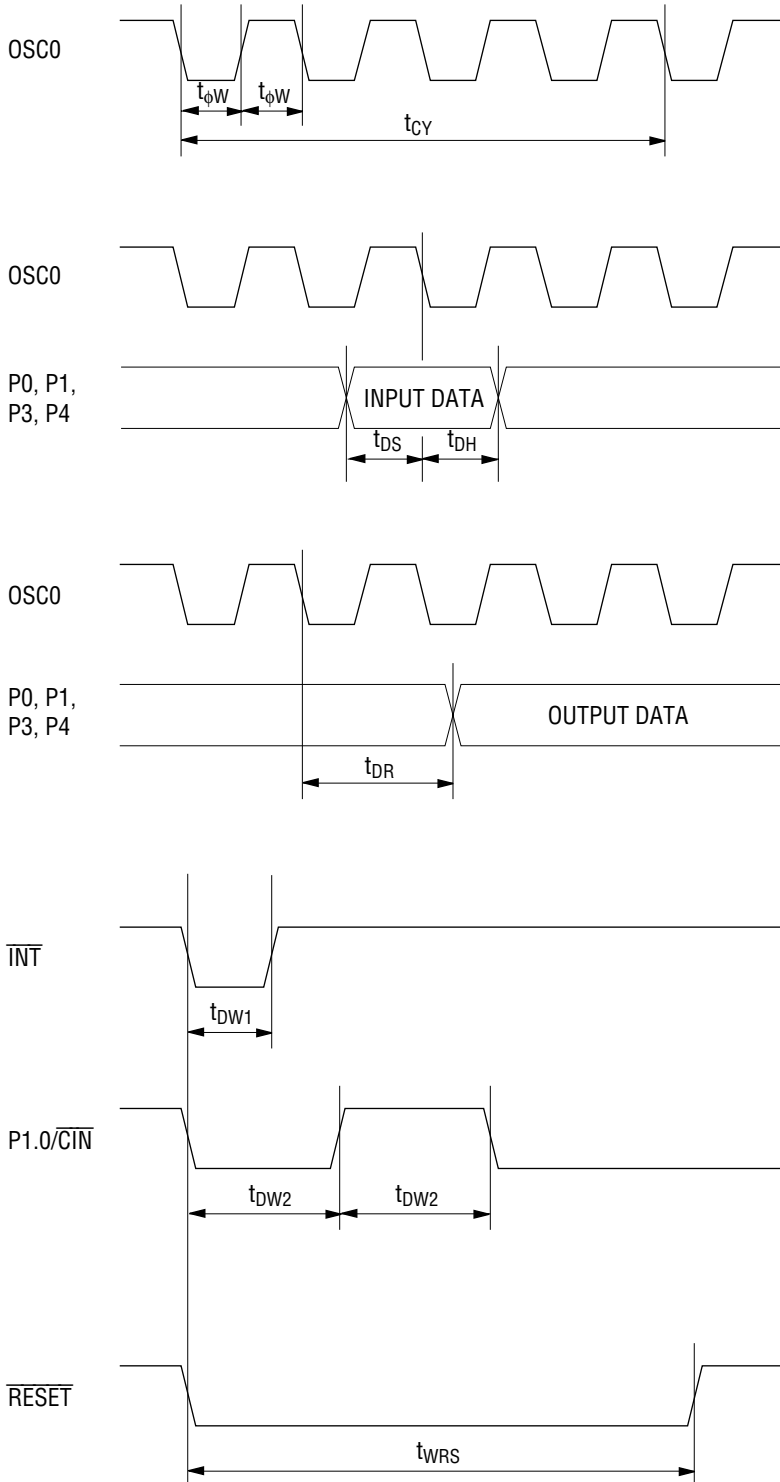



Output Waveforms for LCD Drivers

Static mode

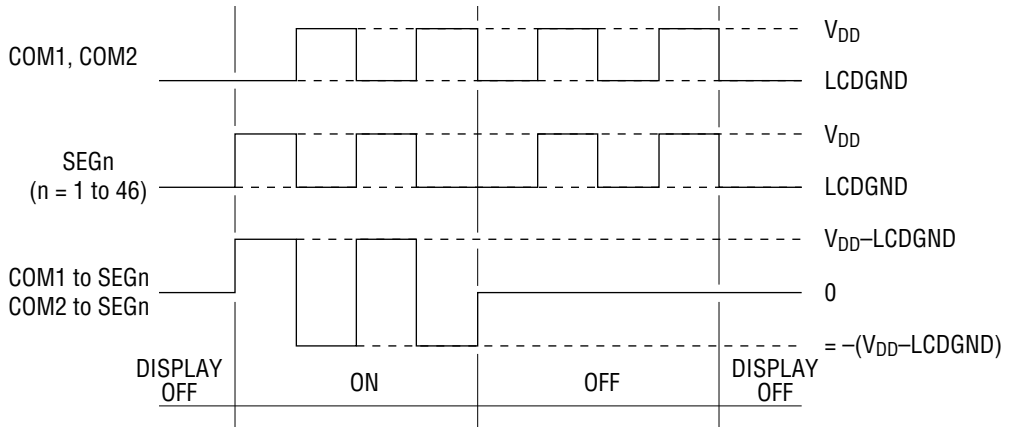

Dynamic mode

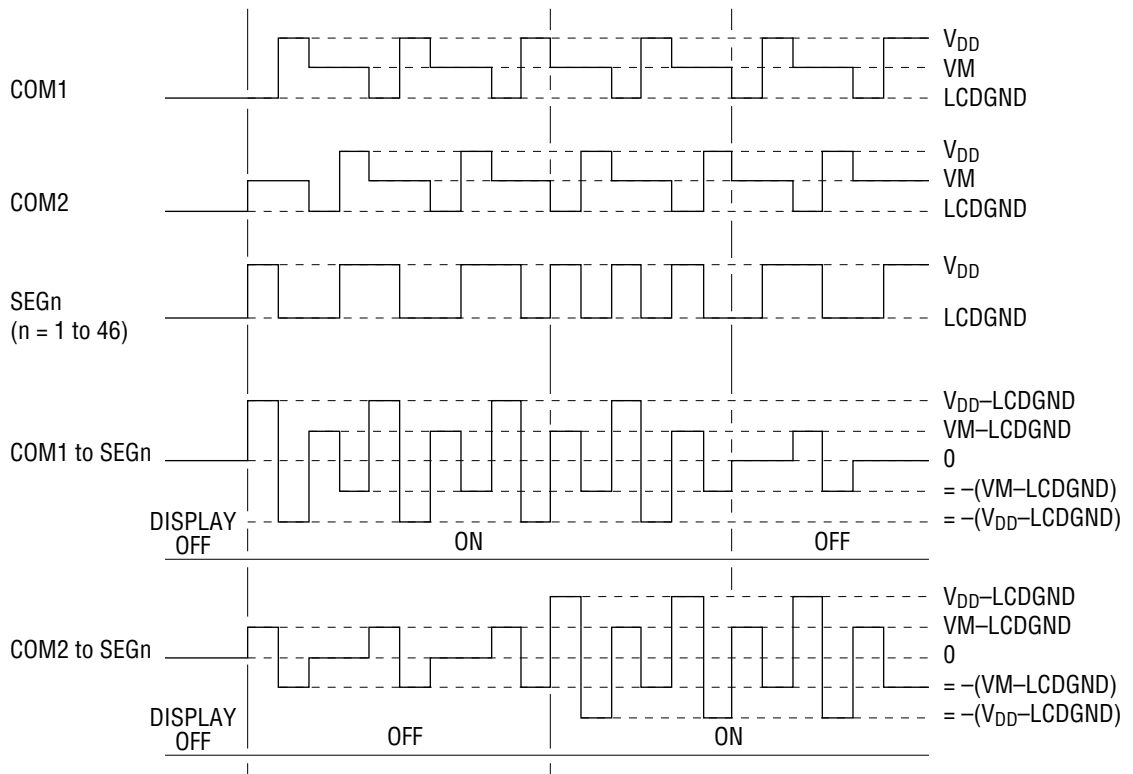

## NOTES ON USE

### Notes on Using Ports 5 and 6 of MSM6442

The MSM6442 uses Port 5 (P5) and Port 6 (P6) to rewrite the display in the LCD and the dedicated registers in LCD section, and to read the interrupt indication flag. Writing and reading is completed when data has been written using P5 and P6, in this order successively. Therefore, if an interrupt occurs during operation of P5 and P6 and these ports are operated by the interrupt routine, the MSM6442 may not operate normally.

### Countermeasure

Disable a process interruption during operation of P5 and P6. Make the program interrupt disabled when rewriting the display in LCD, rewriting a dedicated register such as the system control register (SCR), or reading/resetting the interrupt indication flag. Note that the program examples provided in the User's Manual use the assumption that each program is in the interrupt disabled state. Therefore, when executing any of the program examples in the interrupt enabled state, execute the MDI and MEI instructions according to the following examples:

#### (1) Writing data into a dedicated register

```
LAI  m      Set write data m
MDI                Disable interrupt (*1)
OPD  6
LAI  n      Set control command n
OPD  5
MEI                Enable interrupt (*2)
RPBD 5, 3      End of write processing
```

#### (2) Reading the interrupt indication flag

```
LAI  0FH
MDI                Disable interrupt (*1)
OPD  6
LAI  0AH      Set control command 0AH
OPD  5
IPD  6      Read flag
MEI                Enable interrupt (*2)
RPBD 5, 3      End of read processing
```

\*1 If an accumulator is not saved during interrupt processing, the MDI instruction must be executed before the LAI instruction is executed.

\*2 During actual processing, an interrupt is enabled after the execution of the RPBD 5, 3 instruction.

**PACKAGE DIMENSIONS**

(Unit : mm)

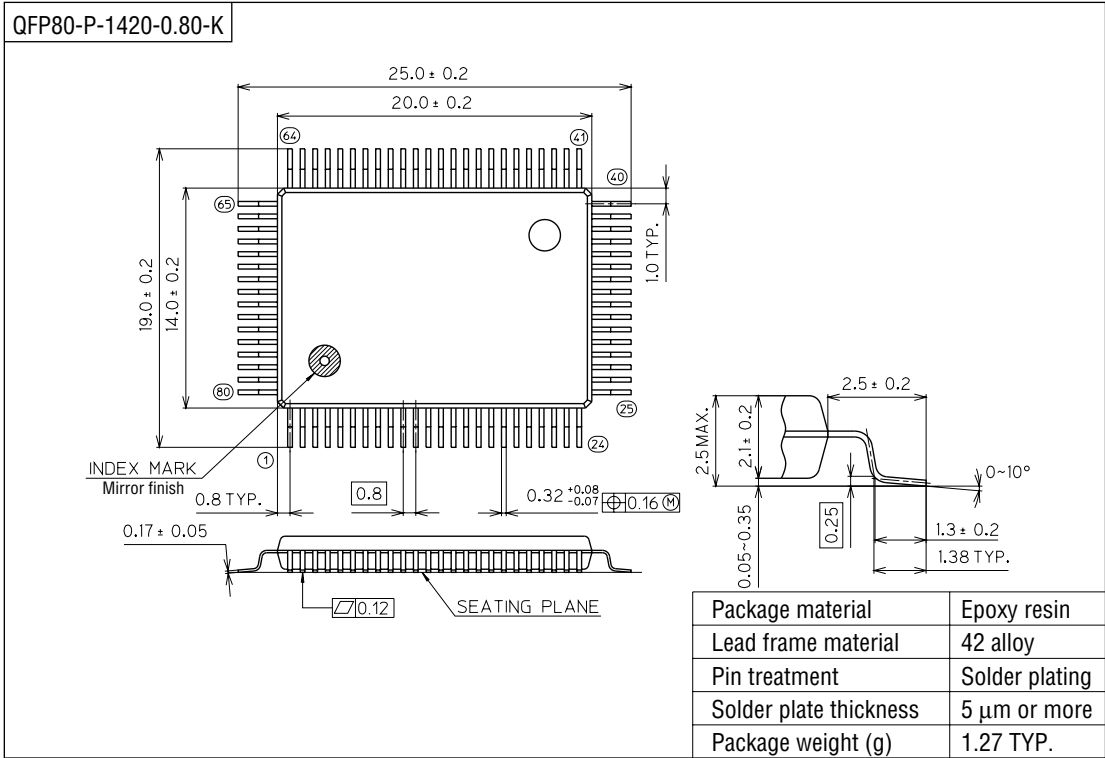

**Notes for Mounting the Surface Mount Type Package**

The SOP, QFP, TSOP, SOJ, QFJ (PLCC), SHP and BGA are surface mount type packages, which are very susceptible to heat in reflow mounting and humidity absorbed in storage. Therefore, before you perform reflow mounting, contact Oki's responsible sales person for the product name, package name, pin number, package code and desired mounting conditions (reflow method, temperature and times).

(Unit : mm)

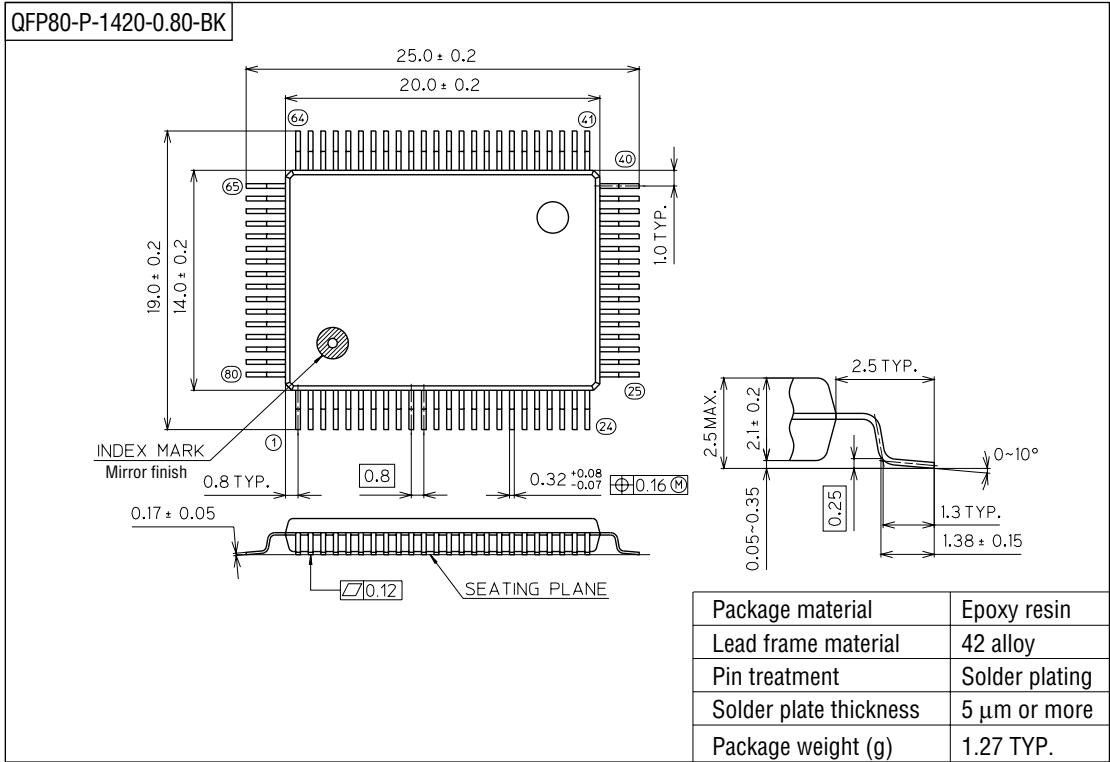

Notes for Mounting the Surface Mount Type Package

The SOP, QFP, TSOP, SOJ, QFJ (PLCC), SHP and BGA are surface mount type packages, which are very susceptible to heat in reflow mounting and humidity absorbed in storage. Therefore, before you perform reflow mounting, contact Oki's responsible sales person for the product name, package name, pin number, package code and desired mounting conditions (reflow method, temperature and times).