



L291

## 5 BIT – D/A CONVERTER AND POSITION AMPLIFIER

- 5 BIT D/A CONVERTER (1/2 LSB MAX LINEARITY ERROR) ;
- ERROR AMPLIFIER ;
- POSITION AMPLIFIER.

### DESCRIPTION

The L291, a monolithic LSI circuit in a 16-lead dual in-line plastic package, is intended for use with the L290 and L292 to form a complete 3 chip DC motor positioning system for applications such as carriage/daisy-wheel position control in typewriters.

The L290/291/292 system can be directly controlled by a microprocessor.

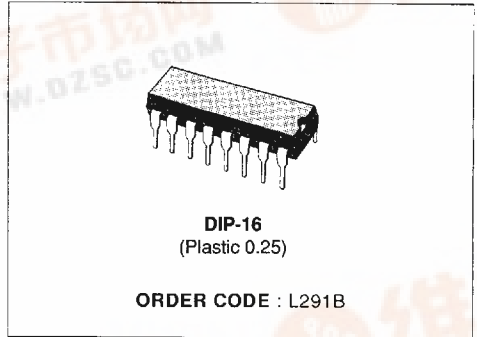

### ABSOLUTE MAXIMUM RATINGS

Symbol	Parameter	Value	Unit
$V_s$	Supply Voltage	$\pm 15$	V
$P_{tot}$	Total Power Dissipation $T_{amb} = 70^\circ\text{C}$	1	W
$T_{slg}, T_j$	Storage and Junction Temperature	-40 to 150	$^\circ\text{C}$

### SYSTEM BLOCK DIAGRAM

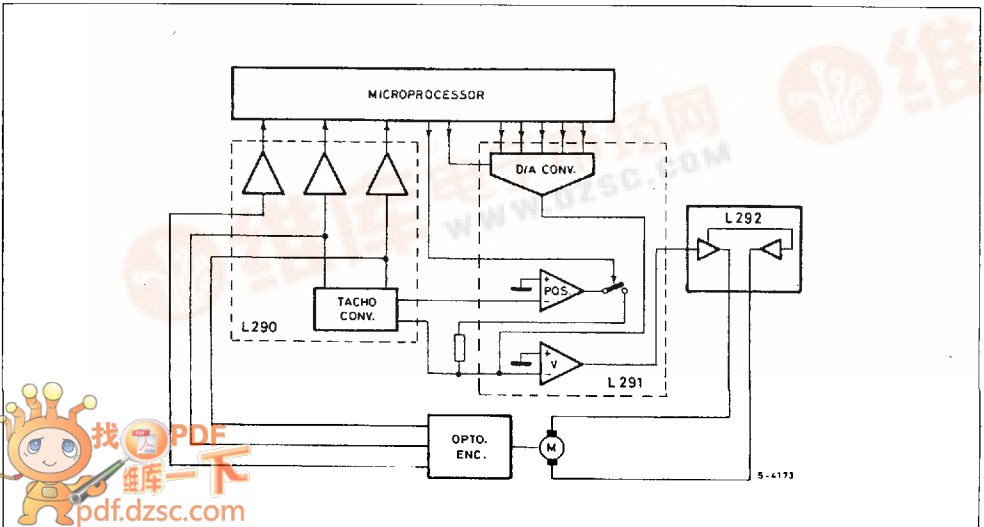

# L291

## CONNECTION DIAGRAM (top view)

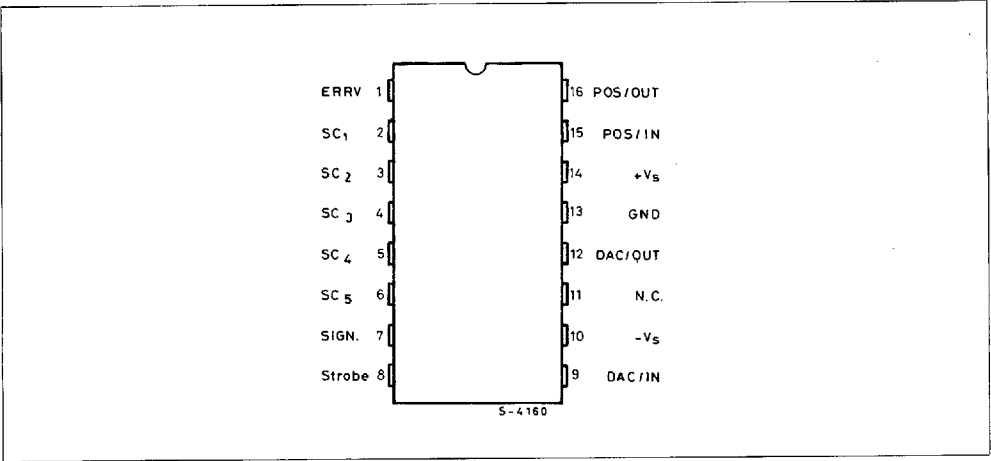

## BLOCK DIAGRAM

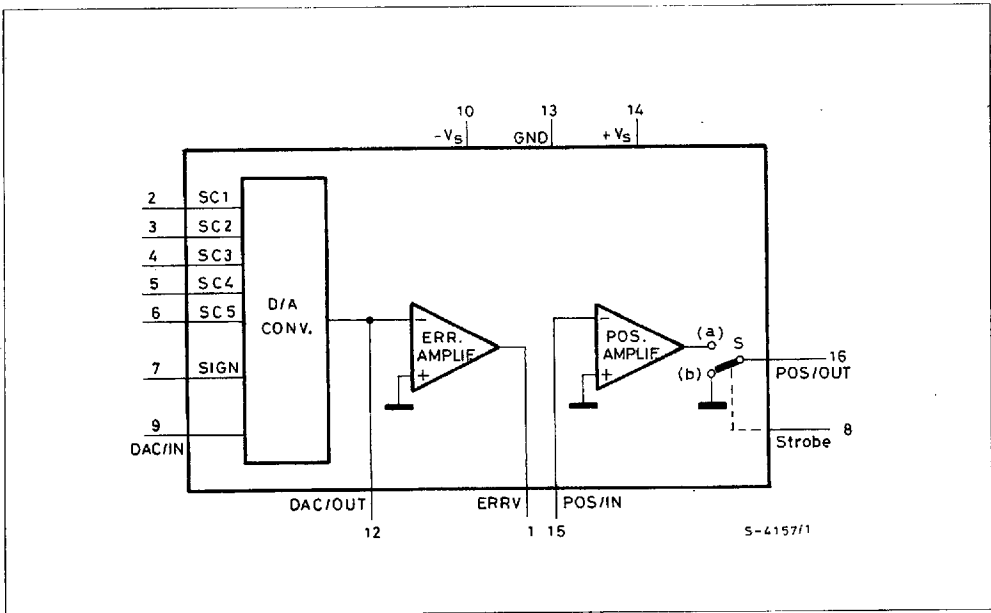

TEST CIRCUIT

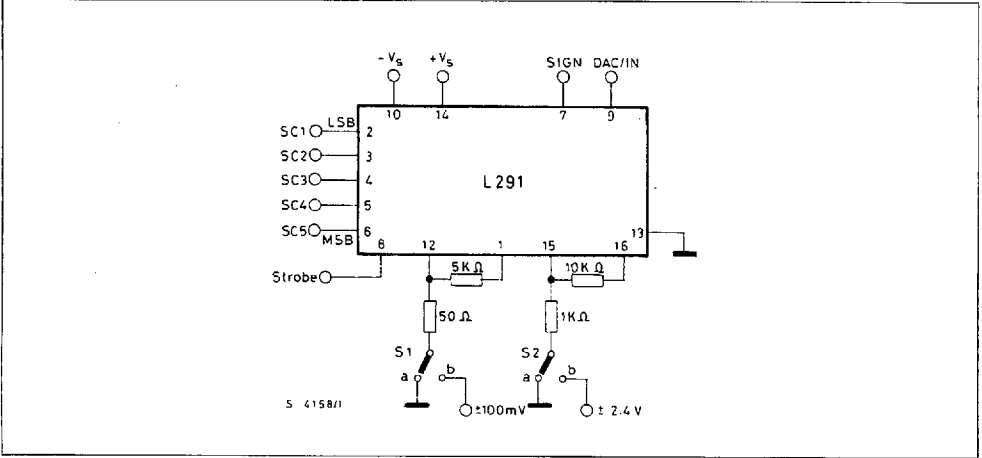

THERMAL DATA

$R_{th(j-amb)}$	Thermal Resistance Junction-ambient	Max	80	°C/W
-----------------	-------------------------------------	-----	----	------

**ELECTRICAL CHARACTERISTICS** (refer to the circuit, S1 and S2 in (a),  $V_s = \pm 12 V$ ,  $T_{amb} = 25^\circ C$ , unless otherwise specified)

Symbol	Parameter	Test conditions	Min.	Typ.	Max.	Unit
$V_s$	Supply Voltage		$\pm 10$		$\pm 15$	V
$I_d$	Quiescent Drain Current			6.5	10	mA

POSITION AMPLIFIER

$V_{strobe}$	Enable Voltage Level	$V_L(S \text{ in } (a)) *$	0		0.8	V
		$V_H(S \text{ in } (b)) *$	2.4		$+ V_s$	V
$V_{os}$	Output Offset Voltage (pin 16)	$V_{strobe} = V_L ; G_v = 20 \text{ dB}$			$\pm 50$	mV
$I_b$	Input Bias Current (pin 15)	$V_{strobe} = V_L$			0.3	$\mu A$
$V_o$	Output Voltage Swing (pin 16)	$V_{strobe} = V_L ; S2 \text{ in } (b) ; V_s = \pm 10.8 V$	$\pm 9$			V
$V_R$	Residual Output Voltage (pin 16)	$V_{strobe} = V_H$			$\pm 20$	mV

\* See block diagram and the note for Position Amplifier.

## ELECTRICAL CHARACTERISTICS (continued)

Symbol	Parameter	Test conditions	Min.	Typ.	Max.	Unit
--------	-----------	-----------------	------	------	------	------

## D/A CONVERTER

$I_{ref}$	Current Reference Input Range (pin 9)		0.3		1.2	mA	
$V_{os}$	Current Reference Offset Voltage (pin 9)	$I_{ref} = 0.3$ to $1.2$ mA All Inputs High			$\pm 20$	mV	
$I_o$	Output Current Range (pin 12)				1.4	mA	
$I_o$	Output Current (pin 12)	$I_{ref} = 0.722$ mA SC1 to SC5 = L	SIGN = L( $I_{o1}$ )	- 1.358	- 1.4	- 1.442	mA
			SIGN = H( $I_{o2}$ )	+ 1.358	+ 1.4	+ 1.442	
$\Delta I_o$	Linearity Error	$I_{o1} + I_{o2}$	- 21		+ 21	$\mu$ A	
		$I_{ref} = 0.722$ mA			1.61	%FS	
$I_{os}$	Pin 12 Output Offset Current (including Error Amplifier bias current)	All Inputs High			$\pm 0.4$	$\mu$ A	
$V_L$	Low Voltage Level (digital inputs)	SC1 = LSB	0		0.8	V	
$V_H$	High Voltage Level (digital inputs)	SC5 = MSB	2.4		+ $V_S$	V	
$I_L$	Digital Inputs Current (low state)	$V_L = 0.4$ V			- 50	$\mu$ A	
$I_H$	Digital Inputs Current (high state)	$V_H = + V_S$			1	$\mu$ A	

## ERROR AMPLIFIER

$V_{os}$	Output Offset Voltage (pin 1)	$I_{ref} = 0.5$ mA ; All Inputs High $G_V = 40$ dB			$\pm 200$	mV
$I_o$	Output Current (pin 1)				$\pm 5$	mA
$V_o$	Output Voltage Swing (pin 1)	All Inputs High S1 in (b) ; $R_L = 10$ K $\Omega$	$\pm 7.4$		$\pm 8.4$	Vp

### D/A CONVERTER

The L291 contains a 5-bit D/A converter accepting a binary code and generating a bipolar output current, the polarity of which depends on the SIGN input. The amplitude of the output current is a multiple of a reference current  $I_{ref}$ .

The maximum output current is

$$I_{FS} = \pm \frac{31}{16} I_{ref}$$

The following table shows the value of  $I_o$  for different input codes. Note that the input bits are active low.

DIGITAL INPUT WORD						Output Current $I_o$
SIGN	SC5 MSB	SC4	SC3	SC2	SC1 LSB	
L	L	L	L	L	L	$-\frac{31}{16} I_{ref}$
L	H	H	H	H	L	$-\frac{1}{16} I_{ref}$
X	H	H	H	H	H	0
H	H	H	H	H	L	$+\frac{1}{16} I_{ref}$
H	L	L	L	L	L	$+\frac{31}{16} I_{ref}$

X = indifferent

L = low

H = high

This D/A converter has a maximum linearity error equal to  $\pm 1/2$  LSB (or  $\pm 1.61\%$  Full Scale) ; that guarantees its monotonicity.

### ERROR AMPLIFIER

In order to have a good stability, the Error Amplifier must work with a closed loop gain greater or equal than 20 dB.

### POSITION AMPLIFIER

It is inserted by means of the strobe signal, TTL and microprocessor compatible. Its output is connected to pin 16 when  $V_{strobe} = \text{Low}$  ; pin 16 is grounded for  $V_{strobe} = \text{High}$ .

**SYSTEM DESCRIPTION : refer to the L292 data sheet.**

# L291

Figure 1 : Complete Application Circuit.

