

[查询W83627SF-PW供应商](#)

[捷多邦，专业PCB打样工厂，24小时加急出货](#)

# W83627SF

## WINBOND I/O

## W83627SF Data Sheet Revision History

	Pages	Dates	Version	Version on Web	Main Contents
1	n.a.	2000/09/17	0.50		First published
2	All	2000/11/15	0.60		New composition
3					
4					
5					
6					
7					
8					
9					
10					

Please note that all data and specifications are subject to change without notice. All the trade marks of products and companies mentioned in this data sheet belong to their respective owners.

### LIFE SUPPORT APPLICATIONS

These products are not designed for use in life support appliances, devices, or systems where malfunction of these products can reasonably be expected to result in personal injury. Winbond customers using or selling these products for use in such applications do so at their own risk and agree to fully indemnify Winbond for any damages resulting from such improper use or sales.

## TABLE OF CONTENTS

<b>GENERAL DESCRIPTION</b>	<b>1</b>
<b>PIN CONFIGURATION FOR W83627SF</b>	<b>6</b>
1. PIN DESCRIPTION	7
1.1 LPC INTERFACE	7
1.2 FDC INTERFACE	8
1.3 MULTI-MODE PARALLEL PORT	9
1.4 SERIAL PORT INTERFACE	13
1.5 KBC INTERFACE	15
1.6 ACPI INTERFACE	15
1.7 GAME PORT & MIDI PORT	16
1.8 GENERAL PURPOSE I/O PORT	17
1.8.1 General Purpose I/O Port 1 (Power source is Vcc)	17
1.8.2 General Purpose I/O Port 2 (Power source is Vcc)	17
1.8.3 General Purpose I/O Port 3 (Power souce is VSB)	18
1.9 SMART CARD INTERFACE AND GENERAL PURPOSE I/O PORT 7 (POWERED BY VCC EXCEPT SCPSNT# WHICH IS POWERED BY VSB)	19
1.10 GENERAL PURPOSE I/O PORT 4 (POWERED BY GP4PWR)	20
1.11 GENERAL PURPOSE I/O PORT 5, 6 (POWERED BY VCC)	20
1.12 32KHZ CRYSTAL OSCILLATOR	21
1.13 POWER PINS	21
<b>2. LPC (LOW PIN COUNT) INTERFACE</b>	<b>22</b>
<b>3. FDC FUNCTIONAL DESCRIPTION</b>	<b>23</b>
3.1 W83627SF FDC	23
3.1.1 AT interface	23
3.1.2 FIFO (Data)	23
3.1.3 Data Separator	24

3.1.4 Write Precompensation	25
3.1.5 Perpendicular Recording Mode	25
3.1.6 FDC Core	25
3.1.7 FDC Commands	25
<b>3.2 REGISTER DESCRIPTIONS</b>	<b>36</b>
3.2.1 Status Register A (SA Register) (Read base address + 0)	36
3.2.2 Status Register B (SB Register) (Read base address + 1)	38
3.2.3 Digital Output Register (DO Register) (Write base address + 2)	40
3.2.4 Tape Drive Register (TD Register) (Read base address + 3)	40
3.2.5 Main Status Register (MS Register) (Read base address + 4)	41
3.2.6 Data Rate Register (DR Register) (Write base address + 4)	41
3.2.7 FIFO Register (R/W base address + 5)	43
3.2.8 Digital Input Register (DI Register) (Read base address + 7)	45
3.2.9 Configuration Control Register (CC Register) (Write base address + 7)	46
<b>4. UART PORT</b>	<b>47</b>
4.1 UNIVERSAL ASYNCHRONOUS RECEIVER/TRANSMITTER (UART A, UART B)	47
4.2 REGISTER ADDRESS	47
4.2.1 UART Control Register (UCR) (Read/Write)	47
4.2.2 UART Status Register (USR) (Read/Write)	50
4.2.3 Handshake Control Register (HCR) (Read/Write)	51
4.2.4 Handshake Status Register (HSR) (Read/Write)	52
4.2.5 UART FIFO Control Register (UFR) (Write only)	53
4.2.6 Interrupt Status Register (ISR) (Read only)	54
4.2.7 Interrupt Control Register (ICR) (Read/Write)	55
4.2.8 Programmable Baud Generator (BLL/BHL) (Read/Write)	55
4.2.9 User-defined Register (UDR) (Read/Write)	56
<b>5. CIR RECEIVER PORT</b>	<b>57</b>
5.1 CIR REGISTERS	57
5.1.1 Bank0.Reg0 - Receiver Buffer Registers (RBR) (Read)	57
5.1.2 Bank0.Reg1 - Interrupt Control Register (ICR)	57
5.1.3 Bank0.Reg2 - Interrupt Status Register (ISR)	57
5.1.4 Bank0~3.Reg3 - CIR Control Register 0/Bank Select Register (CTR0/BSR) (BANK0~3)	58
5.1.5 Bank0.Reg4 - CIR Control Register (CTR)	58
5.1.6 Bank0.Reg5 - UART Line Status Register (USR)	59
5.1.7 Bank0.Reg6 - Remote Infrared Config Register (RIR_CFG)	60

5.1.8 Bank0.Reg7 - User Defined Register (UDR/AUDR)	61
5.1.9 Bank1.Reg0~1 - Baud Rate Divisor Latch (BLL/BHL)	62
5.1.10 Bank1.Reg2 - Version ID Register I (VID)	63
5.1.11 Bank0~3.Reg3 - CIR Control Register 0/Bank Select Register (CTR0/BSR) (BANK0~3)	63
5.1.12 Bank1.Reg4 - Timer Low Byte Register (TMRL)	63
5.1.13 Bank1.Reg5 - Timer High Byte Register (TMRH)	63
<b>6. PARALLEL PORT</b>	<b>64</b>
6.1 PRINTER INTERFACE LOGIC	64
6.2 ENHANCED PARALLEL PORT (EPP)	65
6.2.1 Data Swapper	66
6.2.2 Printer Status Buffer	66
6.2.3 Printer Control Latch and Printer Control Swapper	67
6.2.4 EPP Address Port	67
6.2.5 EPP Data Port 0-3	68
6.2.6 Bit Map of Parallel Port and EPP Registers	68
6.2.7 EPP Pin Descriptions	69
6.2.8 EPP Operation	69
6.3 EXTENDED CAPABILITIES PARALLEL (ECP) PORT	70
6.3.1 ECP Register and Mode Definitions	70
6.3.2 Data and ecpAFifo Port	71
6.3.3 Device Status Register (DSR)	71
6.3.4 Device Control Register (DCR)	72
6.3.5 cFifo (Parallel Port Data FIFO) Mode = 010	73
6.3.6 ecpDFifo (ECP Data FIFO) Mode = 011	73
6.3.7 tFifo (Test FIFO Mode) Mode = 110	73
6.3.8 cnfgA (Configuration Register A) Mode = 111	73
6.3.9 cnfgB (Configuration Register B) Mode = 111	73
6.3.10 ecr (Extended Control Register) Mode = all	74
6.3.11 Bit Map of ECP Port Registers	75
6.3.12 ECP Pin Descriptions	76
6.3.13 ECP Operation	77
6.3.14 FIFO Operation	77
6.3.15 DMA Transfers	78
6.3.16 Programmed I/O (NON-DMA) Mode	78
6.4 EXTENSION FDD MODE (EXTFDD)	78

6.5 EXTENSION 2FDD MODE (EXT2FDD) .....	79
<b>7. KEYBOARD CONTROLLER .....</b>	<b>80</b>
7.1 OUTPUT BUFFER .....	81
7.2 INPUT BUFFER .....	81
7.3 STATUS REGISTER .....	81
7.4 COMMANDS .....	82
7.5 HARDWARE GATEA20/KEYBOARD RESET CONTROL LOGIC .....	84
7.5.1 KB Control Register (Logic Device 5, CR-F0) .....	84
7.5.2 Port 92 Control Register (Default Value = 0x24) .....	84
<b>8. GENERAL PURPOSE I/O .....</b>	<b>85</b>
<b>9. PLUG AND PLAY CONFIGURATION .....</b>	<b>89</b>
9.1 COMPATIBLE PNP .....	89
9.1.1 Extended Function Registers .....	89
9.1.2 Extended Functions Enable Registers (EFERs) .....	90
9.1.3 Extended Function Index Registers (EFIRs), Extended Function Data Registers(EFDRs) .....	90
9.2 CONFIGURATION SEQUENCE .....	90
9.2.1 Enter the extended function mode .....	90
9.2.2 Configure the configuration registers .....	91
9.2.3 Exit the extended function mode .....	91
9.2.4 Software programming example .....	91
<b>10. ACPI REGISTERS FEATURES .....</b>	<b>93</b>
<b>11. SMART CARD INTERFACE .....</b>	<b>94</b>
11.1 RECEIVER BUFFER REGISTER (RBR, READ ONLY AT "BASE ADDRESS + 0" WHEN BDLAB = 0) .....	94
11.2 TRANSMITTER BUFFER REGISTER (TBR, WRITE ONLY AT "BASE ADDRESS + 0" WHEN BDLAB = 0) .....	94
11.3 INTERRUPT CONTROL REGISTER (ICR, AT "BASE ADDRESS + 1" WHEN BDLAB = 0) .....	94
11.4 INTERRUPT STATUS REGISTER (ISR, READ ONLY AT "BASE ADDRESS + 2") .....	95
11.5 SMART CARD FIFO CONTROL REGISTER (SCFR, WRITE ONLY AT "BASE ADDRESS + 2") .....	96
11.6 SMART CARD CONTROL REGISTER (SCCR, WRITE ONLY AT "BASE ADDRESS + 3") .....	97
11.7 INTERRUPT ENABLE REGISTER (IER, AT "BASE ADDRESS + 4") .....	97
11.8 SMART CARD STATUS REGISTER (SCSR, AT "BASE ADDRESS + 5") .....	98
11.9 EXTENDED CONTROL REGISTER (ECR, AT "BASE ADDRESS + 7") .....	99

11.10 BAUD RATE DIVISOR LATCH HIGH AND BAUD RATE DIVISOR LATCH LOW (BHL AND BLL AT "BASE ADDRESS + 1" AND "BASE ADDRESS + 0" RESPECTIVELY WHEN BDLAB = 1)	100
<b>12. SERIAL IRQ</b>	<b>102</b>
12.1 START FRAME	102
12.2 IRQ/DATA FRAME	102
12.3 STOP FRAME	103
<b>13. CONFIGURATION REGISTER</b>	<b>104</b>
13.1 CHIP (GLOBAL) CONTROL REGISTER	104
13.2 LOGICAL DEVICE 0 (FDC)	110
13.3 LOGICAL DEVICE 1 (PARALLEL PORT)	114
13.4 LOGICAL DEVICE 2 (UART A)	115
13.5 LOGICAL DEVICE 3 (UART B)	115
13.6 LOGICAL DEVICE 5 (KBC)	117
13.7 LOGICAL DEVICE 6 (CIR)	118
13.8 LOGICAL DEVICE 7 (GAME PORT AND MIDI PORT AND GPIO PORT 1)	119
13.9 LOGICAL DEVICE 8 (GPIO PORT 2)	120
13.10 LOGICAL DEVICE 9 (GPIO PORT 3,4 ARE POWERED BY STANDBY SOURCE VSB)	122
13.11 LOGICAL DEVICE A (ACPI)	123
13.12 LOGICAL DEVICE B (SMART CARD INTERFACE)	131
13.13 LOGICAL DEVICE C (GPIO PORT 5,6,7 THIS POWER OF THE PORTS IS SOURCE VCC)	131
<b>14. SPECIFICATIONS</b>	<b>134</b>
14.1 ABSOLUTE MAXIMUM RATINGS	134
14.2 DC CHARACTERISTICS	134
<b>15. APPLICATION CIRCUITS</b>	<b>137</b>
15.1 PARALLEL PORT EXTENSION FDD	137
15.2 PARALLEL PORT EXTENSION 2FDD	138
15.3 FOUR FDD MODE	138
<b>16. ORDERING INSTRUCTION</b>	<b>139</b>
<b>17. HOW TO READ THE TOP MARKING</b>	<b>139</b>
<b>18. PACKAGE DIMENSIONS</b>	<b>140</b>



## PRELIMINARY

### GENERAL DESCRIPTION

The W83627SF is the new generation of Winbond's LPC I/O products. It features a whole new interface, namely LPC (**Low Pin Count**) interface, which is supported in mainstream Intel chip-set. This interface as its name suggests is to provide an economical implementation of I/O's interface with lower pin count and still maintains equivalent performance as its ISA interface counterpart. Approximately 40 pins are saved in LPC I/O comparing to ISA implementation. With this additional freedom, we can implement more devices on a single chip as demonstrated in W83627SF's integration of Game Port and MIDI Port. It is fully transparent in terms of software which means no BIOS or device driver update is needed except chip-specific configuration.

As Smart Card application is gaining more and more attention, W83627SF also implements a smart card reader interface featuring Smart wake-up function. This smart card reader interface fully meets the ISO7816 and PC/SC (Personal Computer/Smart Card Workgroup) standards. W83627SF provides a minimum external components and lowest cost solution for smart card applications.

The disk drive adapter functions of W83627SF include a floppy disk drive controller compatible with the industry standard 82077/765, data separator, write pre-compensation circuit, decode logic, data rate selection, clock generator, drive interface control logic, and interrupt and DMA logic. The wide range of functions integrated onto the W83627SF greatly reduces the number of components required for interfacing with floppy disk drives. The W83627SF supports four 360K, 720K, 1.2M, 1.44M, or 2.88M disk drives and data transfer rates of 250 Kb/s, 300 Kb/s, 500 Kb/s, 1 Mb/s, and 2 Mb/s.

The W83627SF provides two high-speed serial communication ports (UARTs), one of which supports serial Infrared communication. Each UART includes a 16-byte send/receive FIFO, a programmable baud rate generator, complete modem control capability, and a processor interrupt system. Both UARTs provide legacy speed with baud rate up to 115.2k bps and also advanced speed with baud rates of **230k**, **460k**, or **921k bps** which support higher speed modems. In addition, the W83627SF provides IR functions: **IrDA 1.0 (SIR** for 1.152K bps) and TV remote IR **Consumer IR**, supporting NEC, RC-5, extended RC-5, and RECS-80 protocols).



## PRELIMINARY

The W83627SF supports one PC-compatible printer port (SPP), Bi-directional Printer port (BPP) and also Enhanced Parallel Port (EPP) and Extended Capabilities Port (ECP). Through the printer port interface pins, also available are: Extension FDD Mode and Extension 2FDD Mode allowing one or two external floppy disk drives to be connected.

The configuration registers support mode selection, function enable/disable, and power down function selection. Furthermore, the configurable PnP features are compatible with the plug-and-play feature demand of Windows 95/98™, which makes system resource allocation more efficient than ever.

The W83627SF provides functions that complies with **ACPI** (*Advanced Configuration and Power Interface*), which includes support of legacy and ACPI power management through **PME#** or **PSOUT#** function pins. For OnNow keyboard Wake-Up, OnNow mouse Wake-Up, and OnNow CIR Wake-Up. The W83627SF also has auto power management to reduce the power consumption.

The keyboard controller is based on 8042 compatible instruction set with a 2K Byte programmable ROM and a 256-Byte RAM bank. Keyboard BIOS firmware are available with optional AMIKEY™-2, Phoenix MultiKey/42™, or customer code.

The W83627SF provides a set of flexible I/O control functions to the system designer through a set of General Purpose I/O ports. These GPIO ports may serve as simple I/O or may be individually configured to provide a predefined alternate function.

The W83627SF is made to fully comply with **Microsoft PC98 and PC99 Hardware Design Guide**. Moreover, W83627SF is made to meet the specification of PC2000/PC2001's requirement in the power management: **ACPI** and **DPM** (Device Power Management).

The W83627SF contains a game port and a MIDI port. The game port is designed to support 2 joysticks and can be applied to all standard PC game control devices. They are very important for a entertainment or consumer computer.

## FEATURES

### General

- Meet LPC Spec. 1.01
- Support LDRQ#(LPC DMA), SERIRQ (serial IRQ)
- Compliant with Microsoft PC2000/PC2001 Hardware Design Guide
- Support DPM (Device Power Management), ACPI
- Programmable configuration settings
- Single 24 or 48 MHz clock input

### FDC

- Compatible with IBM PC AT disk drive systems
- Variable write pre-compensation with track selectable capability
- Support vertical recording format
- DMA enable logic
- 16-byte data FIFOs
- Support floppy disk drives and tape drives
- Detects all overrun and underrun conditions
- Built-in address mark detection circuit to simplify the read electronics
- FDD anti-virus functions with software write protect and FDD write enable signal (write data signal was forced to be inactive)
- Support up to four 3.5-inch or 5.25-inch floppy disk drives
- Completely compatible with industry standard 82077
- 360K/720K/1.2M/1.44M/2.88M format; 250K, 300K, 500K, 1M, 2M bps data transfer rate
- Support **3-mode FDD, and its Win95/98 driver**

### UART

- Two high-speed 16550 compatible UARTs with 16-byte send/receive FIFOs
- MIDI compatible
- Fully programmable serial-interface characteristics:
  - 5, 6, 7 or 8-bit characters
  - Even, odd or no parity bit generation/detection

## PRELIMINARY

- 1, 1.5 or 2 stop bits generation
- Internal diagnostic capabilities:
  - Loop-back controls for communications link fault isolation
  - Break, parity, overrun, framing error simulation
- Programmable baud generator allows division of 1.8461 MHz and 24 MHz by 1 to ( $2^{16}-1$ )
- Maximum baud rate up to **921k bps** for 14.769 MHz and 1.5M bps for 24 MHz

### Infrared

- Support IrDA version 1.0 SIR protocol with maximum baud rate up to 115.2K bps
- Support SHARP ASK-IR protocol with maximum baud rate up to 57,600 bps
- Support Consumer IR

### Parallel Port

- Compatible with IBM parallel port
- Support PS/2 compatible bi-directional parallel port
- Support Enhanced Parallel Port (EPP) – Compatible with IEEE 1284 specification
- Support Extended Capabilities Port (ECP) – Compatible with IEEE 1284 specification
- Extension FDD mode supports disk drive B; and Extension 2FDD mode supports disk drives A and B through parallel port
- Enhanced printer port back-drive current protection

### Keyboard Controller

- 8042 based with optional F/W from AMIKKEY™-2, Phoenix MultiKey/42™ or customer code with 2K bytes of programmable ROM, and 256 bytes of RAM
- Asynchronous Access to Two Data Registers and One status Register
- Software compatibility with the 8042
- Support PS/2 mouse
- Support port 92
- Support both interrupt and polling modes
- **Fast Gate A20 and Hardware Keyboard Reset**
- 8 Bit Timer/ Counter
- Support binary and BCD arithmetic

## PRELIMINARY

- 6 MHz, 8 MHz, 12 MHz, or 16 MHz operating frequency

### Game Port

- Support two separate Joysticks
- Support every Joystick two axis (X,Y) and two button (A,B) controllers

### MIDI Port

- The baud rate is 31.25 Kbaud
- 16-byte input FIFO
- 16-byte output FIFO

### General Purpose I/O Ports

- 40 programmable general purpose I/O ports
- General purpose I/O ports can serve as simple I/O ports, interrupt steering inputs, ,watching dog timer output, power LED output, infrared I/O pins, KBC control I/O pins, suspend LED output, RSMRST# signal, PWROK signal, STR(suspend to DRAM) function, VID control function,

### OnNow Functions

- Keyboard Wake-Up by programmable keys
- Mouse Wake-Up by programmable buttons
- CIR Wake-Up by programmable keys
- SMART Card Wake-up by SCPST
- On Now Wake-Up from all of the ACPI sleeping states (S1-S5)

### Smart Card Reader Interface

- PC/SC T=0, T=1 compliant
- ISO7816 protocol compliant
- With 16-byte send/receive FIFOs
- Programmable baud generator

### Package

- 128-pin PQFP

## PIN CONFIGURATION FOR W83627SF

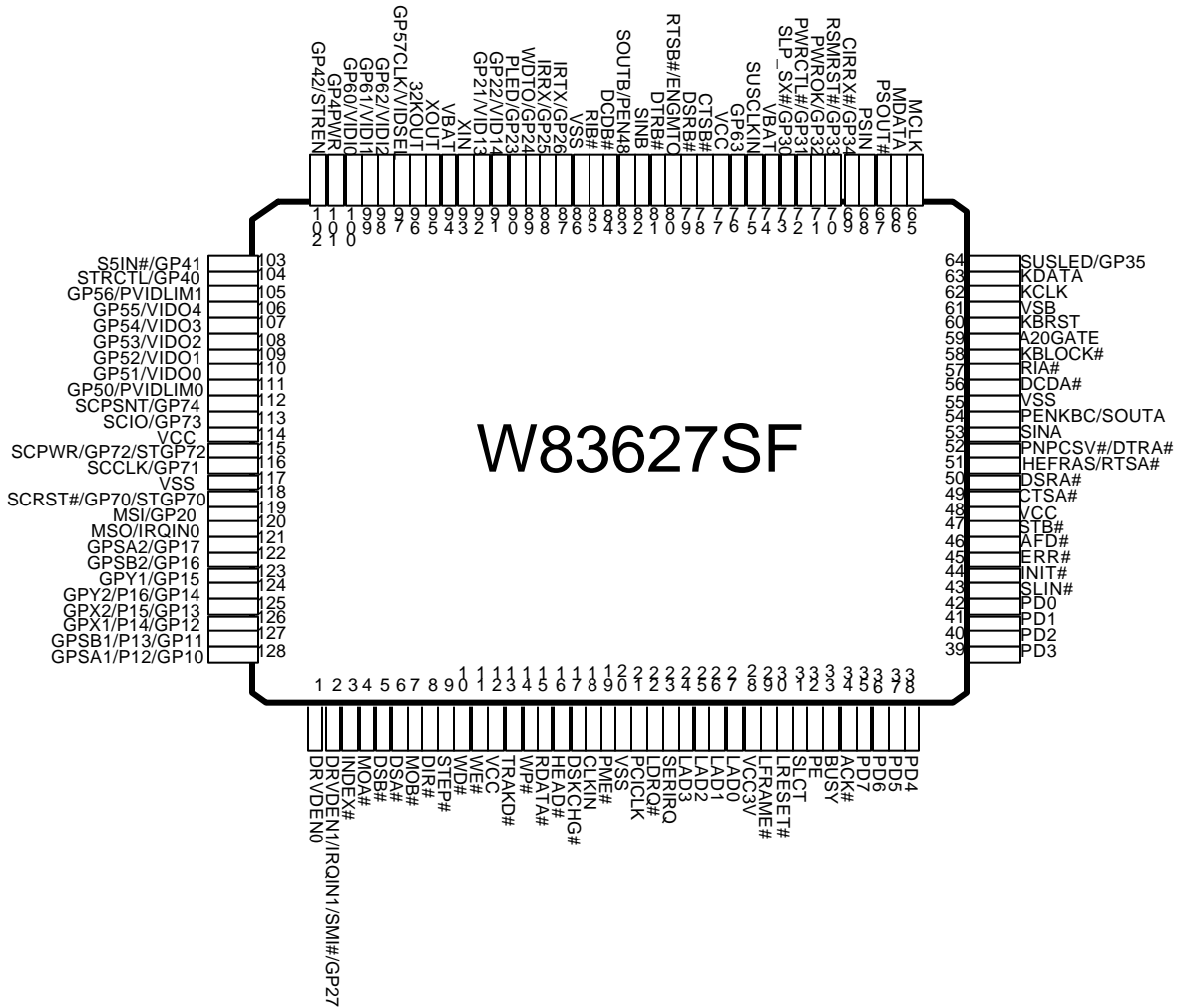

### 1. PIN DESCRIPTION

Note: Please refer to Section 13.2 DC CHARACTERISTICS for details.

I/O <sub>8t</sub>	- TTL level bi-directional pin with 8 mA source-sink capability
I/O <sub>12t</sub>	- TTL level bi-directional pin with 12 mA source-sink capability
I/O <sub>12tp3</sub>	- 3.3V TTL level bi-directional pin with 12 mA source-sink capability
I/OD <sub>12t</sub>	- TTL level bi-directional pin open drain output with 12 mA sink capability
I/OD <sub>16t</sub>	- TTL level bi-directional pin open drain output with 16 mA sink capability
I/OD <sub>24</sub>	- TTL level bi-directional pin open drain output with 24A sink capability
OUT <sub>2</sub>	- Output pin with 2 mA source-sink capability
OUT <sub>12</sub>	- Output pin with 12 mA source-sink capability
O12 <sub>tp3</sub>	- 3.3V output pin with 12 mA source-sink capability
OD <sub>12</sub>	- Open-drain output pin with 12 mA sink capability
OD <sub>24</sub>	- Open-drain output pin with 24 mA sink capability
IN <sub>cs</sub>	- CMOS level Schmitt-trigger input pin
IN <sub>t</sub>	- TTL level input pin
IN <sub>td</sub>	- TTL level input pin with internal pull down resistor
IN <sub>ts</sub>	- TTL level Schmitt-trigger input pin
IN <sub>tsp3</sub>	- 3.3V TTL level Schmitt-trigger input pin

#### 1.1 LPC Interface

SYMBOL	PIN	I/O	FUNCTION
CLKIN	18	IN <sub>t</sub>	System clock input. According to the input frequency 24MHz or 48MHz, it is selectable through register. Default is 24MHz input.
PME#	19	OD <sub>12</sub>	Generated PME event.
PCICLK	21	IN <sub>tsp3</sub>	PCI clock input.
LDRQ#	22	O <sub>12tp3</sub>	Encoded DMA Request signal.
SERIRQ	23	I/OD <sub>12t</sub>	Serial IRQ input/Output.
LAD[3:0]	24-27	I/O <sub>12tp3</sub>	These signal lines communicate address, control, and data information over the LPC bus between a host and a peripheral.
LFRAME#	29	IN <sub>tsp3</sub>	Indicates start of a new cycle or termination of a broken cycle.
LRESET#	30	IN <sub>tsp3</sub>	Reset signal. It can connect to PCIRST# signal on the host.
SUSCLKIN	75	IN <sub>ts</sub>	32khz clock input , for CIR only.

## 1.2 FDC Interface

SYMBOL	PIN	I/O	FUNCTION
DRV DEN0	1	OD <sub>24</sub>	Drive Density Select bit 0.
DRV DEN1	2	OD <sub>12</sub>	Drive Density Select bit 1. (Default)
SMI#		OD <sub>12</sub>	System Management Interrupt.
IRQIN1		IN <sub>t</sub>	Interrupt channel input.
GP27		I/OD <sub>12t</sub>	General purpose I/O port 2 bit 7.
INDEX#	3	IN <sub>CS</sub>	This Schmitt-triggered input from the disk drive is active low when the head is positioned over the beginning of a track marked by an index hole. This input pin is pulled up internally by a 1 K $\Omega$ resistor. The resistor can be disabled by bit 7 of L0-CRF0 (FIPURDWN).
MOA#	4	OD <sub>24</sub>	Motor A On. When set to 0, this pin enables disk drive 0. This is an open drain output.
DSB#	5	OD <sub>24</sub>	Drive Select B. When set to 0, this pin enables disk drive B. This is an open drain output.
DSA#	6	OD <sub>24</sub>	Drive Select A. When set to 0, this pin enables disk drive A. This is an open drain output.
MOB#	7	OD <sub>24</sub>	Motor B On. When set to 0, this pin enables disk drive 1. This is an open drain output.
DIR#	8	OD <sub>24</sub>	Direction of the head step motor. An open drain output. Logic 1 = outward motion Logic 0 = inward motion
STEP#	9	OD <sub>24</sub>	Step output pulses. This active low open drain output produces a pulse to move the head to another track.
WD#	10	OD <sub>24</sub>	Write data. This logic low open drain writes pre-compensation serial data to the selected FDD. An open drain output.
WE#	11	OD <sub>24</sub>	Write enable. An open drain output.
TRAK0#	13	IN <sub>CS</sub>	Track 0. This Schmitt-triggered input from the disk drive is active low when the head is positioned over the outermost track. This input pin is pulled up internally by a 1 K $\Omega$ resistor. The resistor can be disabled by bit 7 of L0-CRF0 (FIPURDWN).

## PRELIMINARY

### 1.2 FDC Interface, continued

SYMBOL	PIN	I/O	FUNCTION
WP#	14	IN <sub>CS</sub>	Write protected. This active low Schmitt input from the disk drive indicates that the diskette is write-protected. This input pin is pulled up internally by a 1 K $\Omega$ resistor. The resistor can be disabled by bit 7 of L0-CRF0 (FIPURDWN).
RDATA#	15	IN <sub>CS</sub>	The read data input signal from the FDD. This input pin is pulled up internally by a 1 K $\Omega$ resistor. The resistor can be disabled by bit 7 of L0-CRF0 (FIPURDWN).
HEAD#	16	OD <sub>24</sub>	Head select. This open drain output determines which disk drive head is active. Logic 1 = side 0 Logic 0 = side 1
DSKCHG#	17	IN <sub>CS</sub>	Diskette change. This signal is active low at power on and whenever the diskette is removed. This input pin is pulled up internally by a 1 K resistor. The resistor can be disabled by bit 7 of L0-CRF0 (FIPURDWN).

### 1.3 Multi-Mode Parallel Port

SYMBOL	PIN	I/O	FUNCTION
SLCT	31	IN <sub>t</sub>  OD <sub>12</sub>  OD <sub>12</sub>	<p>PRINTER MODE: An active high input on this pin indicates that the printer is selected. Refer to the description of the parallel port for definition of this pin in ECP and EPP mode.</p> <p>EXTENSION FDD MODE: WE2# This pin is for Extension FDD B; its function is the same as the WE# pin of FDC.</p> <p>EXTENSION 2FDD MODE: WE2# This pin is for Extension FDD A and B; its function is the same as the WE# pin of FDC.</p>
PE	32	IN <sub>t</sub>  OD <sub>12</sub>  OD <sub>12</sub>	<p>PRINTER MODE: An active high input on this pin indicates that the printer has detected the end of the paper. Refer to the description of the parallel port for the definition of this pin in ECP and EPP mode.</p> <p>EXTENSION FDD MODE: WD2# This pin is for Extension FDD B; its function is the same as the WD# pin of FDC.</p> <p>EXTENSION 2FDD MODE: WD2# This pin is for Extension FDD A and B; its function is the same as the WD# pin of FDC.</p>



### 1.3 Multi-Mode Parallel Port, continued

SYMBOL	PIN	I/O	FUNCTION
BUSY	33	IN <sub>t</sub>  OD <sub>12</sub>  OD <sub>12</sub>	<p>PRINTER MODE: An active high input indicates that the printer is not ready to receive data. Refer to the description of the parallel port for definition of this pin in ECP and EPP mode.</p> <p>EXTENSION FDD MODE: MOB2# This pin is for Extension FDD B; its function is the same as the MOB# pin of FDC.</p> <p>EXTENSION 2FDD MODE: MOB2# This pin is for Extension FDD A and B; its function is the same as the MOB# pin of FDC.</p>
ACK#	34	IN <sub>t</sub>  OD <sub>12</sub>  OD <sub>12</sub>	<p>PRINTER MODE: ACK# An active low input on this pin indicates that the printer has received data and is ready to accept more data. Refer to the description of the parallel port for the definition of this pin in ECP and EPP mode.</p> <p>EXTENSION FDD MODE: DSB2# This pin is for the Extension FDD B; its functions is the same as the DSB# pin of FDC.</p> <p>EXTENSION 2FDD MODE: DSB2# This pin is for Extension FDD A and B; its function is the same as the DSB# pin of FDC.</p>
PD7	35	I/OD <sub>12t</sub>  - OD <sub>12</sub>	<p>PRINTER MODE: PD7 Parallel port data bus bit 7. Refer to the description of the parallel port for the definition of this pin in ECP and EPP mode.</p> <p>EXTENSION FDD MODE: This pin is a tri-state output.</p> <p>EXTENSION 2FDD MODE: DSA2# This pin is for Extension FDD A; its function is the same as the DSA# pin of FDC.</p>
PD6	36	I/OD <sub>12t</sub>  - OD <sub>12</sub>	<p>PRINTER MODE: PD6 Parallel port data bus bit 6. Refer to the description of the parallel port for the definition of this pin in ECP and EPP mode.</p> <p>EXTENSION FDD MODE: This pin is a tri-state output.</p> <p>EXTENSION. 2FDD MODE: MOA2# This pin is for Extension FDD A; its function is the same as the MOA# pin of FDC.</p>
PD5	37	I/O <sub>12t</sub>  - -	<p>PRINTER MODE: PD5 Parallel port data bus bit 5. Refer to the description of the parallel port for the definition of this pin in ECP and EPP mode.</p> <p>EXTENSION FDD MODE: This pin is a tri-state output.</p> <p>EXTENSION 2FDD MODE: This pin is a tri-state output.</p>

### 1.3 Multi-Mode Parallel Port, continued

SYMBOL	PIN	I/O	FUNCTION
PD4	38	I/O <sub>12t</sub>  IN <sub>t</sub>  IN <sub>t</sub>	<p>PRINTER MODE: PD4 Parallel port data bus bit 4. Refer to the description of the parallel port for the definition of this pin in ECP and EPP mode.</p> <p>EXTENSION FDD MODE: DSKCHG2# This pin is for Extension FDD B; the function of this pin is the same as the DSKCHG# pin of FDC. It is pulled high internally.</p> <p>EXTENSION 2FDD MODE: DSKCHG2# This pin is for Extension FDD A and B; this function of this pin is the same as the DSKCHG# pin of FDC. It is pulled high internally.</p>
PD3	39	I/O <sub>12t</sub>  IN <sub>t</sub>  IN <sub>t</sub>	<p>PRINTER MODE: PD3 Parallel port data bus bit 3. Refer to the description of the parallel port for the definition of this pin in ECP and EPP mode.</p> <p>EXTENSION FDD MODE: RDATA2# This pin is for Extension FDD B; its function is the same as the RDATA# pin of FDC. It is pulled high internally.</p> <p>EXTENSION 2FDD MODE: RDATA2# This pin is for Extension FDD A and B; its function is the same as the RDATA# pin of FDC. It is pulled high internally.</p>
PD2	40	I/O <sub>12t</sub>  IN <sub>t</sub>  IN <sub>t</sub>	<p>PRINTER MODE: PD2 Parallel port data bus bit 2. Refer to the description of the parallel port for the definition of this pin in ECP and EPP mode.</p> <p>EXTENSION FDD MODE: WP2# This pin is for Extension FDD B; its function is the same as the WP# pin of FDC. It is pulled high internally.</p> <p>EXTENSION. 2FDD MODE: WP2# This pin is for Extension FDD A and B; its function is the same as the WP# pin of FDC. It is pulled high internally.</p>
PD1	41	I/O <sub>12t</sub>  IN <sub>t</sub>  IN <sub>t</sub>	<p>PRINTER MODE: PD1 Parallel port data bus bit 1. Refer to the description of the parallel port for the definition of this pin in ECP and EPP mode.</p> <p>EXTENSION FDD MODE: TRAK02# This pin is for Extension FDD B; its function is the same as the TRAK0# pin of FDC. It is pulled high internally.</p> <p>EXTENSION. 2FDD MODE: TRAK02# This pin is for Extension FDD A and B; its function is the same as the TRAK0# pin of FDC. It is pulled high internally.</p>

### 1.3 Multi-Mode Parallel Port, continued

SYMBOL	PIN	I/O	FUNCTION
PD0	42	I/O <sub>12t</sub>  IN <sub>t</sub>  IN <sub>t</sub>	<p>PRINTER MODE: PD0 Parallel port data bus bit 0. Refer to the description of the parallel port for the definition of this pin in ECP and EPP mode.</p> <p>EXTENSION FDD MODE: INDEX2# This pin is for Extension FDD B; its function is the same as the INDEX# pin of FDC. It is pulled high internally.</p> <p>EXTENSION 2FDD MODE: INDEX2# This pin is for Extension FDD A and B; its function is the same as the INDEX# pin of FDC. It is pulled high internally.</p>
SLIN#	43	OD <sub>12</sub>  OD <sub>12</sub>  OD <sub>12</sub>	<p>PRINTER MODE: SLIN# Output line for detection of printer selection. Refer to the description of the parallel port for the definition of this pin in ECP and EPP mode.</p> <p>EXTENSION FDD MODE: STEP2# This pin is for Extension FDD B; its function is the same as the STEP# pin of FDC.</p> <p>EXTENSION 2FDD MODE: STEP2# This pin is for Extension FDD A and B; its function is the same as the STEP# pin of FDC.</p>
INIT#	44	OD <sub>12</sub>  OD <sub>12</sub>  OD <sub>12</sub>	<p>PRINTER MODE: INIT# Output line for the printer initialization. Refer to the description of the parallel port for the definition of this pin in ECP and EPP mode.</p> <p>EXTENSION FDD MODE: DIR2# This pin is for Extension FDD B; its function is the same as the DIR# pin of FDC.</p> <p>EXTENSION 2FDD MODE: DIR2# This pin is for Extension FDD A and B; its function is the same as the DIR# pin of FDC.</p>
ERR#	45	IN <sub>t</sub>  OD <sub>12</sub>  OD <sub>12</sub>	<p>PRINTER MODE: ERR# An active low input on this pin indicates that the printer has encountered an error condition. Refer to the description of the parallel port for the definition of this pin in ECP and EPP mode.</p> <p>EXTENSION FDD MODE: HEAD2# This pin is for Extension FDD B; its function is the same as the HEAD#pin of FDC.</p> <p>EXTENSION 2FDD MODE: HEAD2# This pin is for Extension FDD A and B; its function is the same as the HEAD# pin of FDC.</p>



**PRELIMINARY**

1.3 Multi-Mode Parallel Port, continued

SYMBOL	PIN	I/O	FUNCTION
AFD#	46	OD <sub>12</sub>	PRINTER MODE: AFD# An active low output from this pin causes the printer to auto feed a line after a line is printed. Refer to the description of the parallel port for the definition of this pin in ECP and EPP mode.
		OD <sub>12</sub>	EXTENSION FDD MODE: DRVDEN0 This pin is for Extension FDD B; its function is the same as the DRVDEN0 pin of FDC.
		OD <sub>12</sub>	EXTENSION 2FDD MODE: DRVDEN0 This pin is for Extension FDD A and B; its function is the same as the DRVDEN0 pin of FDC.
STB#	47	OD <sub>12</sub>	PRINTER MODE: STB# An active low output is used to latch the parallel data into the printer. Refer to the description of the parallel port for the definition of this pin in ECP and EPP mode.
		-	EXTENSION FDD MODE: This pin is a tri-state output.
		-	EXTENSION 2FDD MODE: This pin is a tri-state output.

**1.4 Serial Port Interface**

SYMBOL	PIN	I/O	FUNCTION
CTSA#	49	IN <sub>t</sub>	Clear To Send. It is the modem control input.
CTSB#	78		The function of these pins can be tested by reading bit 4 of the handshake status register.
DSRA#	50	IN <sub>t</sub>	Data Set Ready. An active low signal indicates the modem or data set is ready to establish a communication link and transfer data to the UART.
DSRB#	79		
RTSA#	51	I/O <sub>8t</sub>	UART A Request To Send. An active low signal informs the modem or data set that the controller is ready to send data.
HEFRAS			During power-on reset, this pin is pulled down internally and is defined as HEFRAS, which provides the power-on value for CR26 bit 6 (HEFRAS). A 4.7 kΩ is recommended if intends to pull up. (select 4EH as configuration I/O port's address)

## PRELIMINARY

## 1.4 Serial Port Interface, continued

SYMBOL	PIN	I/O	FUNCTION
RTSB# ENGMTO	80	I/O <sub>8t</sub>	UART B Request To Send. An active low signal informs the modem or data set that the controller is ready to send data. Power on setting pin for enabling Watch Dog timer and its countdown. This pin is pulled down internally and provides the power-on value for bit 0 of CR30 and a count value of 0x0A for CRF6 in logical device 8. A 4.7 k $\Omega$ is recommended if intends to pull up.
DTRA# PNPCSV#	52	I/O <sub>8t</sub>	UART A Data Terminal Ready. An active low signal informs the modem or data set that the controller is ready to communicate. During power-on reset, this pin is pulled down internally and is defined as PNPCSV#, which provides the power-on value for CR24 bit 0 (PNPCSV#). A 4.7 k $\Omega$ is recommended if intends to pull up. (clear the default value of FDC, UARTs, PRT, Game port and MIDI port)
DTRB#	81	I/O <sub>8t</sub>	UART B Data Terminal Ready. An active low signal informs the modem or data set that controller is ready to communicate.
SINA SINB	53 82	IN <sub>t</sub>	Serial Input. It is used to receive serial data through the communication link.
SOUTA PENKBC	54	I/O <sub>8t</sub>	UART A Serial Output. It is used to transmit serial data out to the communication link. During power-on reset, this pin is pulled down internally and is defined as PENKBC, which provides the power-on value for CR24 bit 2 (ENKBC). A 4.7 k $\Omega$ resistor is recommended if intends to pull up. (enable KBC)
SOUTB PEN48	83	I/O <sub>8t</sub>	UART B Serial Output. During power-on reset, this pin is pulled down internally and is defined as PEN48, which provides the power-on value for CR24 bit 6 (EN48). A 4.7 k $\Omega$ resistor is recommended if intends to pull up.
DCDA# DCDB#	56 84	IN <sub>t</sub>	Data Carrier Detect. An active low signal indicates the modem or data set has detected a data carrier.
RIA# RIB#	57 85	IN <sub>t</sub>	Ring Indicator. An active low signal indicates that a ring signal is being received from the modem or data set.

## 1.5 KBC Interface

SYMBOL	PIN	I/O	FUNCTION
KBLOCK#	58	IN <sub>t</sub>	Keyboard inhibit control input. This pin is after system reset. Internal pull high. (KBC P17)
A20GATE	59	OUT <sub>12</sub>	Gate A20 output. This pin is high after system reset. (KBC P21)
KBRST	60	OUT <sub>12</sub>	Keyboard reset. This pin is high after system reset. (KBC P20)
KCLK	62	I/OD <sub>16t</sub>	Keyboard Clock.
KDATA	63	I/OD <sub>16t</sub>	Keyboard Data.
MCLK	65	I/OD <sub>16t</sub>	PS2 Mouse Clock.
MDATA	66	I/OD <sub>16t</sub>	PS2 Mouse Data.

## 1.6 ACPI Interface

SYMBOL	PIN	I/O	FUNCTION
PSOUT#	67	OD <sub>12</sub>	Panel Switch Output. This signal is used for Wake-Up system from S5 <sub>cold</sub> state. This pin is pulse output, active low.
PSIN	68	IN <sub>td</sub>	Panel Switch Input. This pin is high active with an internal pull down resistor.
VBAT	74	PWR	Battery voltage input.

## 1.7 Game Port &amp; MIDI Port

SYMBOL	PIN	I/O	FUNCTION
MSI	119	INt	MIDI serial data input.
GP20		I/OD <sub>12t</sub>	General purpose I/O port 2 bit 0.
MSO	120	OUT <sub>12</sub>	MIDI serial data output. (Default)
IRQIN0		INt	Alternate Function input: Interrupt channel input.
GPSA2	121	INcs	Active-low, Joystick I switch input 2. This pin has an internal pull-up resistor. (Default)
GP17		I/OD <sub>12t</sub>	General purpose I/O port 1 bit 7.
GPSB2	122	INcs	Active-low, Joystick II switch input 2. This pin has an internal pull-up resistor. (Default)
GP16		I/OD <sub>12</sub>	General purpose I/O port 1 bit 6.
GPY1	123	I/OD <sub>12</sub>	Joystick I timer pin. this pin connect to Y positioning variable resistors for the Josystick. (Default)
GP15		I/OD <sub>12t</sub>	General purpose I/O port 1 bit 5.
GPY2	124	I/OD <sub>12</sub>	Joystick II timer pin. this pin connect to Y positioning variable resistors for the Josystick. (Default)
GP14		I/OD <sub>12t</sub>	General purpose I/O port 1 bit 4.
P16		I/OD <sub>12t</sub>	Alternate Function Output:KBC P16 I/O port.
GPX2	125	I/OD <sub>12</sub>	Joystick II timer pin. this pin connect to X positioning variable resistors for the Josystick. (Default)
GP13		I/OD <sub>12t</sub>	General purpose I/O port 1 bit 3.
P15		I/OD <sub>12t</sub>	Alternate Function Output:KBC P15 I/O port.

## 1.7 Game Port &amp; MIDI Port, continued

SYMBOL	PIN	I/O	FUNCTION
GPX1	126	I/OD <sub>12</sub>	Joystick I timer pin. this pin connect to X positioning variable resistors for the Josystick. (Default)
GP12		I/OD <sub>12t</sub>	General purpose I/O port 1 bit 2.
P14		I/OD <sub>12t</sub>	Alternate Function Output:KBC P14 I/O port.
GPSB1	127	INcs	Active-low, Joystick II switch input 1. (Default)
GP11		I/OD <sub>12t</sub>	General purpose I/O port 1 bit 1.
P13		I/OD <sub>12t</sub>	Alternate Function Output:KBC P13 I/O port.
GPSA1	128	INcs	Active-low, Joystick I switch input 1. (Default)
GP10		I/OD <sub>12t</sub>	General purpose I/O port 1 bit 0.
P12		I/OD <sub>12t</sub>	Alternate Function Output:KBC P12 I/O port.

## 1.8 General Purpose I/O Port

### 1.8.1 General Purpose I/O Port 1 (Power source is Vcc)

see 1.7 Game Port

### 1.8.2 General Purpose I/O Port 2 (Power source is Vcc)

SYMBOL	PIN	I/O	FUNCTION
GP26	87	I/OD <sub>12t</sub>	General purpose I/O port 2 bit 6.
IRTX		OUT <sub>12</sub>	Alternate Function Output: Infrared Transmitter Output. (Default)
GP25	88	I/OD <sub>12t</sub>	General purpose I/O port 2 bit 5.
IRRX		IN <sub>ts</sub>	Alternate Function Input: Infrared Receiver input. (Default)
GP24	89	I/OD <sub>12t</sub>	General purpose I/O port 2 bit 4.
WDTO		OD <sub>12</sub>	Watch dog timer output. (Default)
GP23	90	I/OD <sub>24t</sub>	General purpose I/O port 2 bit 3.
PLED		OD <sub>24</sub>	Power LED output, this signal is low after system reset. (Default)
GP22	91	I/OD <sub>12t</sub>	General purpose I/O port 2 bit 2.
VIDI4		IN <sub>t</sub>	Alternate VID input bit 4.
GP21	92	I/OD <sub>12t</sub>	General purpose I/O port 2 bit 1.
VIDI3		IN <sub>t</sub>	Alternate VID input bit 3.



## 1.8.3 General Purpose I/O Port 3 (Power source is VSB)

SYMBOL	PIN	I/O	FUNCTION
GP35 SUSLED	64	I/OD <sub>24t</sub> OD <sub>24</sub>	General purpose I/O port 3 bit 5. Suspend LED output, it can program to flash when suspend state. This function can work without VCC. (Default)
GP34 CIRRX#	69	I/OD <sub>12t</sub> OD <sub>12</sub>	General purpose I/O port 3 bit 4. Consumer IR receiving input. This pin can Wake-Up system from S5 <sub>cold</sub> . (Default)
GP33 RSMRST#	70	I/OD <sub>12t</sub> OD <sub>12</sub>	General purpose I/O port 3 bit 3. This pin generates the RSMRST signal while the VSB come in. (Default)
GP32 PWROK	71	I/OD <sub>12t</sub> OD <sub>12</sub>	General purpose I/O port 3 bit 2. This pin generates the PWROK signal while the VCC come in. (Default)
GP31 PWRCTL#	72	I/OD <sub>12t</sub> OD <sub>12</sub>	General purpose I/O port 3 bit 1. This pin generates the PWRCTL# signal while the power failure. (Default)
GP30 SLP_SX#	73	I/OD <sub>12t</sub> INt	General purpose I/O port 3 bit 0. Chpset suspend C status input.

### 1.9 SMART CARD Interface and General Purpose I/O port 7 (Powered by VCC except SCPSNT# which is powered by VSB)

SYMBOL	PIN	I/O	FUNCTION
SCPSNT GP74	112	IN <sub>ts</sub> I/O <sub>12ts</sub>	Smart card present detection Schmitt-trigger input. General purpose I/O port 7 bit 4.
SCIO GP73	113	I/O <sub>12t</sub> I/OD <sub>12t</sub>	Smart card data I/O channel. General purpose I/O port 7 bit 3.
SCPWR GP72 STGP72	115	OUT <sub>12</sub> I/O <sub>12t</sub>	Smart card power control. General purpose I/O port 7 bit 2. Power on setting pin for selecting functions of GP7. Setting value is latched on the rising edge of POWEROK. This pin is internally pulled down during power on, a 4.7 kΩ resistor is recommended if intends to pull up. Refer to detailed description of CR2C bit 6, 5.
SCCLK GP71	116	OUT <sub>12</sub> I/O <sub>12t</sub>	Smart card clock output. General purpose I/O port 7 bit 1.
SCRST# GP70 STGP70	118	OUT <sub>12</sub> I/O <sub>12t</sub>	Smart card reset output. General purpose I/O port 7 bit 0. Power on setting pin for selecting functions of GP7. Setting value is latched on the rising edge of POWEROK. This pin is internally pulled down during power on, a 4.7 kΩ resistor is recommended if intends to pull up. Refer to detailed description of CR2C bit 6, 5.

### 1.10 General Purpose I/O Port 4 (Powered by GP4PWR)

SYMBOL	PIN	I/O	FUNCTION
GP4PWR	101	PWR	+5V stand-by power supply dedicated for GP4.
GP42 STREN	102	I/O <sub>12t</sub>	General purpose I/O port 4 bit 2. Power on setting pin for selecting functions of GP4. Setting value is latched on the rising edge of RSMRST#. This pin is internally pulled down during power on, a 4.7 kΩ resistor is recommended if intends to pull up. Refer to detailed description of CR29 bit 0.
GP41 S5IN#	103	I/O <sub>12t</sub>	General purpose I/O port 4 bit 1. S5 input signal to indicate in S5 state.
GP40 STRCTL	104	I/O <sub>12t</sub>	General purpose I/O port 4 bit 0. For suspend to ram function to control Ram power.

### 1.11 General Purpose I/O Port 5, 6 (Powered by VCC)

SYMBOL	PIN	I/O	FUNCTION
GP57 VIDSEL	97	I/O <sub>12t</sub>	General purpose I/O port 5 bit 7. Power on setting pin for selecting VID function. Setting value is latched on the rising edge of POWEROK. This pin is internally pulled down during power on, a 4.7 kΩ resistor is recommended if intends to pull up. Refer to detailed description of CR2C bit 7.
GP56 PVIDLIM1	105	I/O <sub>12t</sub>	General purpose I/O port 5 bit 6. Power on setting pin for selecting VID guarding function. Setting value is latched on the rising edge of POWEROK. This pin is internally pulled down during power on, a 4.7 kΩ resistor is recommended if intends to pull up. Refer to detailed description of bit 6 of CRFA in logical device C.
GP55 VIDO4	106	I/OD <sub>12t</sub> OD <sub>12</sub>	General purpose I/O port 5 bit 5. Alternate VID output bit 4.
GP54 VIDO3	107	I/OD <sub>12t</sub> OD <sub>12</sub>	General purpose I/O port 5 bit 4. Alternate VID output bit 3.
GP53 VIDO2	108	I/OD <sub>12t</sub> OD <sub>12</sub>	General purpose I/O port 5 bit 3. Alternate VID output bit 2.

**PRELIMINARY**
**1.11 General Purpose I/O Port 5, 6 (Powered by VCC), continued**

<b>SYMBOL</b>	<b>PIN</b>	<b>I/O</b>	<b>FUNCTION</b>
GP52 VIDO1	109	I/OD <sub>12t</sub> OD <sub>12</sub>	General purpose I/O port 5 bit 2. Alternate VID output bit 1.
GP51 VIDO0	110	I/OD <sub>12t</sub> OD <sub>12</sub>	General purpose I/O port 5 bit 1. Alternate VID output bit 0.
GP50 PVIDLIM0	111	I/O <sub>12t</sub>	General purpose I/O port 5 bit 0. Power on setting pin for selecting VID guarding function. Setting value is latched on the rising edge of POWEROK. This pin is internally pulled down during power on, a 4.7 kΩ resistor is recommended if intends to pull up. Refer to detailed description of bit 5 of CRFA in logical device C.
GP63	76	I/OD <sub>12t</sub>	General purpose I/O port 6 bit 2.
GP62 VIDI2	98	I/OD <sub>12t</sub> IN <sub>t</sub>	General purpose I/O port 6 bit 2. Alternate VID input bit 2.
GP61 VIDI1	99	I/OD <sub>12t</sub> IN <sub>t</sub>	General purpose I/O port 6 bit 1. Alternate VID input bit 1.
GP60 VIDI0	100	I/OD <sub>12t</sub> IN <sub>t</sub>	General purpose I/O port 6 bit 0. Alternate VID input bit 0.

**1.12 32KHz crystal oscillator**

<b>SYMBOL</b>	<b>PIN</b>	<b>I/O</b>	<b>FUNCTION</b>
XIN	93	IN	Crystal input
VBAT	94	PWR	Dedicated power supply for oscillator.
XOUT	95	OUT	Crystal output
CLK32KOUT	96	OUT <sub>2</sub>	32KHz output clock.

**1.13 POWER PINS**

<b>SYMBOL</b>	<b>PIN</b>	<b>FUNCTION</b>
VCC3V	28	+3.3V power supply for driving 3V on host interface.
VCC	12, 48, 77, 114	+5V power supply for the digital circuitry.
VSB	61	+5V stand-by power supply for the digital circuitry.
VSS	20, 55, 86, 117	Ground.



## PRELIMINARY

### 2. LPC (LOW PIN COUNT) INTERFACE

LPC interface is to replace ISA interface serving as a bus interface between host (chip-set) and peripheral (Winbond I/O). Data transfer on the LPC bus are serialized over a 4 bit bus. The general characteristics of the interface implemented in Winbond LPC I/O are:

- One control line, namely LFRAME#, which is used by the host to start or stop transfers. No peripherals drive this signal.
- The LAD[3:0] bus, which communicates information serially. The information conveyed are cycle type, cycle direction, chip selection, address, data, and wait states.
- MR (master reset) of Winbond ISA I/O is replaced with a active low reset signal, namely LRESET#, in Winbond LPC I/O.
- An additional 33 MHz PCI clock is needed in Winbond LPC I/O for synchronization.
- DMA requests are issued through LDRQ#.
- Interrupt requests are issued through SERIRQ.
- Power management events are issued through PME#.

Comparing to its ISA counterpart, LPC implementation saves up to 40 pin counts (see table below) free for integrating more devices on a single chip.

Winbond I/O	Interface pins	count
W83977EF	D[7:0], SA[15:0], DRQ[3:0], DACK#[3:0], TC, IOR#, IOW#, IOCHRDY, IRQs	49
W83627SF	LAD[3:0], LFRAME#, PCICLK, LDRQ#, SERIRQ, PME#	9
save		40

The transition from ISA to LPC is transparent in terms of software which means no BIOS or device driver update is needed except chip-specific configuration.

## 3. FDC FUNCTIONAL DESCRIPTION

### 3.1 W83627SF FDC

The floppy disk controller of the W83627SF integrates all of the logic required for floppy disk control. The FDC implements a PC/AT or PS/2 solution. All programmable options default to compatible values. The FIFO provides better system performance in multi-master systems. The digital data separator supports up to 2 M bits/sec data rate.

The FDC includes the following blocks: AT interface, Precompensation, Data Rate Selection, Digital Data Separator, FIFO, and FDC Core.

#### 3.1.1 AT interface

The interface consists of the standard asynchronous signals: RD#, WR#, A0-A3, IRQ, DMA control, and a data bus. The address lines select between the configuration registers, the FIFO and control/status registers. This interface can be switched between PC/AT, Model 30, or PS/2 normal modes. The PS/2 register sets are a superset of the registers found in a PC/AT.

#### 3.1.2 FIFO (Data)

The FIFO is 16 bytes in size and has programmable threshold values. All command parameter information and disk data transfers go through the FIFO. Data transfers are governed by the RQM and DIO bits in the Main Status Register.

The FIFO defaults to disabled mode after any form of reset. This maintains PC/AT hardware compatibility. The default values can be changed through the CONFIGURE command. The advantage of the FIFO is that it allows the system a larger DMA latency without causing disk errors. The following tables give several examples of the delays with a FIFO. The data are based upon the following formula:



PRELIMINARY

$$\text{THRESHOLD \#} \times (1/\text{DATA/RATE}) * 8 - 1.5 \mu\text{S} = \text{DELAY}$$

FIFO THRESHOLD	MAXIMUM DELAY TO SERVICING AT 500K BPS
	Data Rate
1 Byte	$1 \times 16 \mu\text{S} - 1.5 \mu\text{S} = 14.5 \mu\text{S}$
2 Byte	$2 \times 16 \mu\text{S} - 1.5 \mu\text{S} = 30.5 \mu\text{S}$
8 Byte	$8 \times 16 \mu\text{S} - 1.5 \mu\text{S} = 6.5 \mu\text{S}$
15 Byte	$15 \times 16 \mu\text{S} - 1.5 \mu\text{S} = 238.5 \mu\text{S}$
FIFO THRESHOLD	MAXIMUM DELAY TO SERVICING AT 1M BPS
	Data Rate
1 Byte	$1 \times 8 \mu\text{S} - 1.5 \mu\text{S} = 6.5 \mu\text{S}$
2 Byte	$2 \times 8 \mu\text{S} - 1.5 \mu\text{S} = 14.5 \mu\text{S}$
8 Byte	$8 \times 8 \mu\text{S} - 1.5 \mu\text{S} = 62.5 \mu\text{S}$
15 Byte	$15 \times 8 \mu\text{S} - 1.5 \mu\text{S} = 118.5 \mu\text{S}$

At the start of a command the FIFO is always disabled and command parameters must be sent based upon the RQM and DIO bit settings in the main status register. When the FDC enters the command execution phase, it clears the FIFO of any data to ensure that invalid data are not transferred.

An overrun and underrun will terminate the current command and the data transfer. Disk writes will complete the current sector by generating a 00 pattern and valid CRC. Reads require the host to remove the remaining data so that the result phase may be entered.

DMA transfers are enabled with the SPECIFY command and are initiated by the FDC by activating the DRQ pin during a data transfer command. The FIFO is enabled directly by asserting DACK# and addresses need not be valid.

Note that if the DMA controller is programmed to function in verify mode a pseudo read is performed by the FDC based only on DACK#. This mode is only available when the FDC has been configured into byte mode (FIFO disabled) and is programmed to do a read. With the FIFO enabled the above operation is performed by using the new VERIFY command. No DMA operation is needed. j @

### 3.1.3 Data Separator

The function of the data separator is to lock onto the incoming serial read data. When a lock is achieved the serial front end logic of the chip is provided with a clock which is synchronized to the read data. The synchronized clock, called the Data Window, is used to internally sample the serial data portion of the bit cell, and the alternate state samples the clock portion. Serial to parallel conversion logic separates the read data into clock and data bytes.

The Digital Data Separator (DDS) has three parts: control logic, error adjustment, and speed tracking. The DDS circuit cycles once every 12 clock cycles ideally. Any data pulse input will be synchronized and then adjusted by immediate error adjustment. The control logic will generate RDD and RWD for every pulse input. During any cycle where no data pulse is present, the DDS cycles are based on speed. A digital integrator is used to keep track of the speed changes in the input data stream.

### 3.1.4 Write Precompensation

The write precompensation logic is used to minimize bit shifts in the RDDATA stream from the disk drive. Shifting of bits is a known phenomenon in magnetic media and is dependent on the disk media and the floppy drive.

The FDC monitors the bit stream that is being sent to the drive. The data patterns that require precompensation are well known. Depending upon the pattern, the bit is shifted either early or late relative to the surrounding bits.

### 3.1.5 Perpendicular Recording Mode

The FDC is also capable of interfacing directly to perpendicular recording floppy drives. Perpendicular recording differs from the traditional longitudinal method in that the magnetic bits are oriented vertically. This scheme packs more data bits into the same area.

FDCs with perpendicular recording drives can read standard 3.5" floppy disks and can read and write perpendicular media. Some manufacturers offer drives that can read and write standard and perpendicular media in a perpendicular media drive.

A single command puts the FDC into perpendicular mode. All other commands operate as they normally do. The perpendicular mode requires a 1 Mbps data rate for the FDC. At this data rate the FIFO eases the host interface bottleneck due to the speed of data transfer to or from the disk.

### 3.1.6 FDC Core

The W83627SF FDC is capable of performing twenty commands. Each command is initiated by a multi-byte transfer from the microprocessor. The result can also be a multi-byte transfer back to the microprocessor. Each command consists of three phases: command, execution, and result.

#### Command

The microprocessor issues all required information to the controller to perform a specific operation.

#### Execution

The controller performs the specified operation.

#### Result

After the operation is completed, status information and other housekeeping information is provided to the microprocessor.

### 3.1.7 FDC Commands

Command Symbol Descriptions:

C:	Cylinder number 0 - 256
D:	Data Pattern
DIR:	Step Direction
	DIR = 0, step out





## PRELIMINARY

	DIR = 1, step in
DS0:	Disk Drive Select 0
DS1:	Disk Drive Select 1
DTL:	Data Length
EC:	Enable Count
EOT:	End of Track
EFIFO:	Enable FIFO
EIS:	Enable Implied Seek
EOT:	End of track
FIFOTHR:	FIFO Threshold
GAP:	Gap length selection
GPL:	Gap Length
H:	Head number
HDS:	Head number select
HLT:	Head Load Time
HUT:	Head Unload Time
LOCK:	Lock EFIFO, FIFOTHR, PTRTRK bits prevent affected by software reset
MFM:	MFM or FM Mode
MT:	Multitrack
N:	The number of data bytes written in a sector
NCN:	New Cylinder Number
ND:	Non-DMA Mode
OW:	Overwritten
PCN:	Present Cylinder Number
POLL:	Polling Disable
PRETRK:	Precompensation Start Track Number
R:	Record
RCN:	Relative Cylinder Number
R/W:	Read/Write
SC:	Sector/per cylinder
SK:	Skip deleted data address mark
SRT:	Step Rate Time
ST0:	Status Register 0
ST1:	Status Register 1
ST2:	Status Register 2
ST3:	Status Register 3
WG:	Write gate alters timing of WE



**PRELIMINARY**

**(1) Read Data**

PHASE	R/W	D7	D6	D5	D4	D3	D2	D1	D0	REMARKS	
Command	W	MT	MFM	SK	0	0	1	1	0	Command codes	
	W	0	0	0	0	0	HDS	DS1	DS0		
	W	----- C -----									Sector ID information prior to command execution
	W	----- H -----									
	W	----- R -----									
	W	----- N -----									
	W	----- EOT -----									
	W	----- GPL -----									
	W	----- DTL -----									
Execution										Data transfer between the FDD and system	
Result	R	----- ST0 -----								Status information after command execution	
	R	----- ST1 -----									
	R	----- ST2 -----									
	R	----- C -----								Sector ID information after command execution	
	R	----- H -----									
	R	----- R -----									
	R	----- N -----									

# W83627SF



**PRELIMINARY**

**(2) Read Deleted Data**

PHASE	R/W	D7	D6	D5	D4	D3	D2	D1	D0	REMARKS
Command	W	MT	MFM	SK	0	1	1	0	0	Command codes  Sector ID information prior to command execution
	W	0	0	0	0	0	HDS	DS1	DS0	
	W	----- C -----								
	W	----- H -----								
	W	----- R -----								
	W	----- N -----								
	W	----- EOT -----								
	W	----- GPL -----								
W	----- DTL -----									
Execution										Data transfer between the FDD and system
Result	R	----- ST0 -----								Status information after command execution
	R	----- ST1 -----								
	R	----- ST2 -----								
	R	----- C -----								Sector ID information after command execution
	R	----- H -----								
	R	----- R -----								
	R	----- N -----								



PRELIMINARY

(3) Read A Track

PHASE	R/W	D7	D6	D5	D4	D3	D2	D1	D0	REMARKS
Command	W	0	MFM	0	0	0	0	1	0	Command codes  Sector ID information prior to command execution
	W	0	0	0	0	0	HDS	DS1	DS0	
	W	----- C -----								
	W	----- H -----								
	W	----- R -----								
	W	----- N -----								
	W	----- EOT -----								
	W	----- GPL -----								
	W	----- DTL -----								
Execution										Data transfer between the FDD and system; FDD reads contents of all cylinders from index hole to EOT
Result	R	----- ST0 -----								Status information after command execution  Sector ID information after command execution
	R	----- ST1 -----								
	R	----- ST2 -----								
	R	----- C -----								
	R	----- H -----								
	R	----- R -----								
	R	----- N -----								



## PRELIMINARY

### (4) Read ID

PHASE	R/W	D7	D6	D5	D4	D3	D2	D1	D0	REMARKS
Command	W	0	MFM	0	0	1	0	1	0	Command codes
	W	0	0	0	0	0	HDS	DS1	DS0	
Execution										The first correct ID information on the cylinder is stored in Data Register
Result	R									Status information after command execution
	R									
	R									
	R									Disk status after the command has been completed
	R									
	R									
	R									

### (5) Verify

PHASE	R/W	D7	D6	D5	D4	D3	D2	D1	D0	REMARKS	
Command	W	MT	MFM	SK	1	0	1	1	0	Command codes	
	W	EC	0	0	0	0	HDS	DS1	DS0		
	W										Sector ID information prior to command execution
	W										
	W										
	W										
	W										
	W										
Execution										No data transfer takes place	
Result	R									Status information after command execution	
	R										
	R										
	R									Sector ID information after command execution	
	R										
	R										
	R										



## PRELIMINARY

### (6) Version

PHASE	R/W	D7	D6	D5	D4	D3	D2	D1	D0	REMARKS
Command	W	0	0	0	1	0	0	0	0	Command code
Result	R	1	0	0	1	0	0	0	0	Enhanced controller

### (7) Write Data

PHASE	R/W	D7	D6	D5	D4	D3	D2	D1	D0	REMARKS	
Command	W	MT	MFM	0	0	0	1	0	1	Command codes	
	W	0	0	0	0	0	HDS	DS1	DS0		
	W	-----C-----									Sector ID information prior to Command execution
	W	-----H-----									
	W	-----R-----									
	W	-----N-----									
	W	-----EOT-----									
	W	-----GPL-----									
	W	-----DTL-----									
Execution										Data transfer between the FDD and system	
Result	R	-----ST0-----								Status information after Command execution	
	R	-----ST1-----									
	R	-----ST2-----									
	R	-----C-----								Sector ID information after Command execution	
	R	-----H-----									
	R	-----R-----									
	R	-----N-----									



## PRELIMINARY

### (8) Write Deleted Data

PHASE	R/W	D7	D6	D5	D4	D3	D2	D1	D0	REMARKS	
Command	W	MT	MFM	0	0	1	0	0	1	Command codes	
	W	0	0	0	0	0	HDS	DS1	DS0		
	W	----- C -----									Sector ID information prior to command execution
	W	----- H -----									
	W	----- R -----									
	W	----- N -----									
	W	----- EOT -----									
	W	----- GPL -----									
	W	----- DTL -----									
Execution										Data transfer between the FDD and system	
Result	R	----- ST0 -----								Status information after command execution	
	R	----- ST1 -----									
	R	----- ST2 -----									
	R	----- C -----								Sector ID information after command execution	
	R	----- H -----									
	R	----- R -----									
	R	----- N -----									



**PRELIMINARY**

**(9) Format A Track**

PHASE	R/W	D7	D6	D5	D4	D3	D2	D1	D0	REMARKS	
Command	W	0	MFM	0	0	1	1	0	1	Command codes	
	W	0	0	0	0	0	HDS	DS1	DS0		
	W	----- N -----									Bytes/Sector
	W	----- SC -----									Sectors/Cylinder
	W	----- GPL -----									Gap 3
	W	----- D -----									Filler Byte
Execution for Each Sector Repeat:	W	----- C -----								Input Sector Parameters	
	W	----- H -----									
	W	----- R -----									
	W	----- N -----									
Result	R	----- ST0 -----								Status information after command execution	
	R	----- ST1 -----									
	R	----- ST2 -----									
	R	----- Undefined -----									
	R	----- Undefined -----									
	R	----- Undefined -----									
	R	----- Undefined -----									

**(10) Recalibrate**

PHASE	R/W	D7	D6	D5	D4	D3	D2	D1	D0	REMARKS
Command	W	0	0	0	0	0	1	1	1	Command codes
	W	0	0	0	0	0	0	DS1	DS0	
Execution										Head retracted to Track 0 Interrupt

**(11) Sense Interrupt Status**

PHASE	R/W	D7	D6	D5	D4	D3	D2	D1	D0	REMARKS
Command	W	0	0	0	0	1	0	0	0	Command code
Result	R	----- ST0 -----								Status information at the end of each seek operation
	R	----- PCN -----								



## PRELIMINARY

### (12) Specify

PHASE	R/W	D7	D6	D5	D4	D3	D2	D1	D0	REMARKS
Command	W	0	0	0	0	0	0	1	1	Command codes
	W	-----SRT-----				-----HUT-----				
	W	-----HLT----- ND								

### (13) Seek

PHASE	R/W	D7	D6	D5	D4	D3	D2	D1	D0	REMARKS
Command	W	0	0	0	0	1	1	1	1	Command codes
	W	0	0	0	0	0	HDS	DS1	DS0	
	W	-----NCN-----								
Execution	R									Head positioned over proper cylinder on diskette

### (14) Configure

PHASE	R/W	D7	D6	D5	D4	D3	D2	D1	D0	REMARKS
Command	W	0	0	0	1	0	0	1	1	Configure information
	W	0	0	0	0	0	0	0	0	
	W	0	EIS	EFIFO	POLL	-----FIFOTHR----				
	W	-----PRETRK-----								
Execution										Internal registers written

### (15) Relative Seek

PHASE	R/W	D7	D6	D5	D4	D3	D2	D1	D0	REMARKS
Command	W	1	DIR	0	0	1	1	1	1	Command codes
	W	0	0	0	0	0	HDS	DS1	DS0	
	W	-----RCN-----								



## PRELIMINARY

### (16) Dumpreg

PHASE	R/W	D7	D6	D5	D4	D3	D2	D1	D0	REMARKS	
Command	W	0	0	0	0	1	1	1	0	Registers placed in FIFO	
Result	R	----- PCN-Drive 0-----									
	R	----- PCN-Drive 1-----									
	R	----- PCN-Drive 2-----									
	R	----- PCN-Drive 3-----									
	R	-----SRT-----					----- HUT-----				
	R	----- HLT-----									ND
	R	----- SC/EOT-----									
	R	LOCK	0	D3	D2	D1	D0	GAP	WG		
	R	0	EIS	EFIFO	POLL		----- FIFOTHR-----				
R	-----PRETRK-----										

### (17) Perpendicular Mode

PHASE	R/W	D7	D6	D5	D4	D3	D2	D1	D0	REMARKS
Command	W	0	0	0	1	0	0	1	0	Command Code
	W	OW	0	D3	D2	D1	D0	GAP	WG	

### (18) Lock

PHASE	R/W	D7	D6	D5	D4	D3	D2	D1	D0	REMARKS
Command	W	LOCK	0	0	1	0	1	0	0	Command Code
Result	R	0	0	0	LOCK	0	0	0	0	

### (19) Sense Drive Status

PHASE	R/W	D7	D6	D5	D4	D3	D2	D1	D0	REMARKS
Command	W	0	0	0	0	0	1	0	0	Command Code
	W	0	0	0	0	0	HDS	DS1	DS0	
Result	R	----- ST3-----								Status information about disk drive

### (20) Invalid

PHASE	R/W	D7	D6	D5	D4	D3	D2	D1	D0	REMARKS
Command	W	----- Invalid Codes-----								Invalid codes (no operation-FDC goes to standby state)
Result	R	----- ST0-----								ST0 = 80H



PRELIMINARY

## 3.2 Register Descriptions

There are several status, data, and control registers in W83627SF. These registers are defined below:

ADDRESS OFFSET	REGISTER	
	READ	WRITE
base address + 0	SA REGISTER	
base address + 1	SB REGISTER	
base address + 2		DO REGISTER
base address + 3	TD REGISTER	TD REGISTER
base address + 4	MS REGISTER	DR REGISTER
base address + 5	DT (FIFO) REGISTER	DT (FIFO) REGISTER
base address + 7	DI REGISTER	CC REGISTER

### 3.2.1 Status Register A (SA Register) (Read base address + 0)

This register is used to monitor several disk interface pins in PS/2 and Model 30 modes. In PS/2 mode, the bit definitions for this register are as follows:

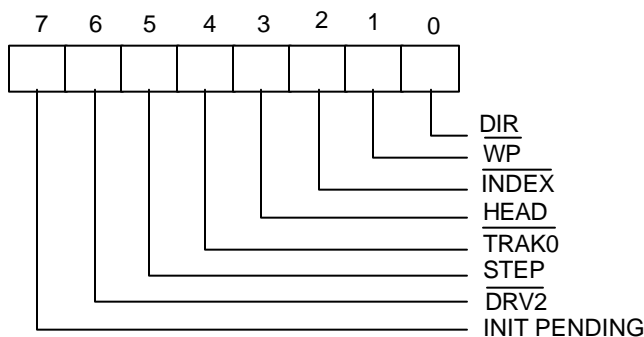

INIT PENDING (Bit 7):

This bit indicates the value of the floppy disk interrupt output.

DRV2# (Bit 6):

- 0 A second drive has been installed
- 1 A second drive has not been installed

STEP (Bit 5):

This bit indicates the complement of STEP# output.

TRAK0# (Bit 4):

This bit indicates the value of TRAK0# input.

**HEAD (Bit 3):**

This bit indicates the complement of HEAD# output.

- 0 side 0
- 1 side 1

**INDEX# (Bit 2):**

This bit indicates the value of INDEX# output.

**WP# (Bit 1):**

- 0 disk is write-protected
- 1 disk is not write-protected

**DIR (Bit 0)**

This bit indicates the direction of head movement.

- 0 outward direction
- 1 inward direction

In PS/2 Model 30 mode, the bit definitions for this register are as follows:

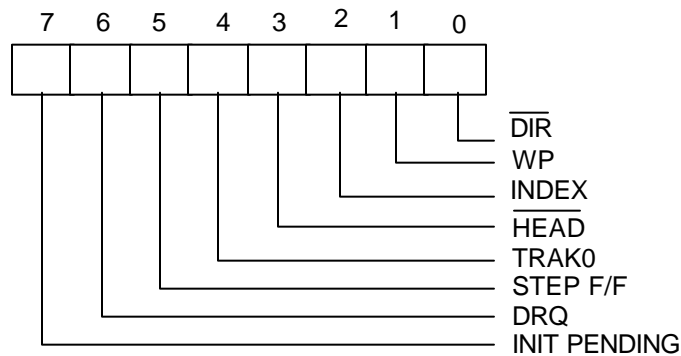

**INIT PENDING (Bit 7):**

This bit indicates the value of the floppy disk interrupt output.

**DRQ (Bit 6):**

This bit indicates the value of DRQ output pin.

**STEP F/F (Bit 5):**

This bit indicates the complement of latched STEP# output.

**TRAK0 (Bit 4):**

This bit indicates the complement of TRAK0# input.



**PRELIMINARY**

**HEAD# (Bit 3):**

This bit indicates the value of HEAD# output.

- 0 side 1
- 1 side 0

**INDEX (Bit 2):**

This bit indicates the complement of INDEX# output.

**WP (Bit 1):**

- 0 disk is not write-protected
- 1 disk is write-protected

**DIR# (Bit 0)**

This bit indicates the direction of head movement.

- 0 inward direction
- 1 outward direction

**3.2.2 Status Register B (SB Register) (Read base address + 1)**

This register is used to monitor several disk interface pins in PS/2 and Model 30 modes. In PS/2 mode, the bit definitions for this register are as follows:

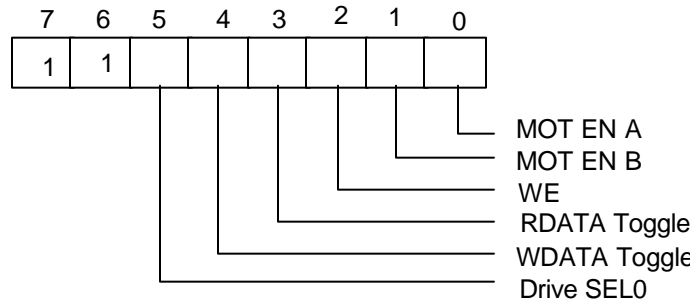

**Drive SEL0 (Bit 5):**

This bit indicates the status of DO REGISTER bit 0 (drive select bit 0).

**WDATA Toggle (Bit 4):**

This bit changes state at every rising edge of the WD# output pin.

**RDATA Toggle (Bit 3):**

This bit changes state at every rising edge of the RDATA# output pin.

**WE (Bit 2):**

This bit indicates the complement of the WE# output pin.

### MOT EN B (Bit 1)

This bit indicates the complement of the MOB# output pin.

### MOT EN A (Bit 0)

This bit indicates the complement of the MOA# output pin.

In PS/2 Model 30 mode, the bit definitions for this register are as follows:

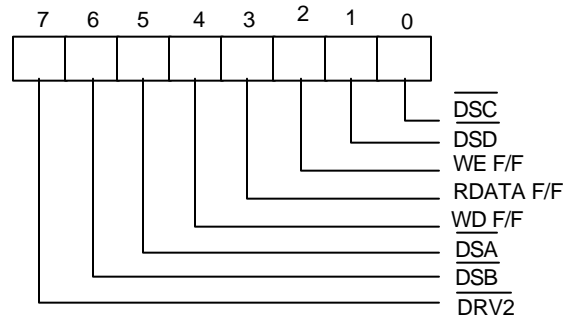

### DRV2# (Bit 7):

- 0 A second drive has been installed
- 1 A second drive has not been installed

### DSB# (Bit 6):

This bit indicates the status of DSB# output pin.

### DSA# (Bit 5):

This bit indicates the status of DSA# output pin.

### WD F/F (Bit 4):

This bit indicates the complement of the latched WD# output pin at every rising edge of the WD# output pin.

### RDATA F/F (Bit 3):

This bit indicates the complement of the latched RDATA# output pin .

### WE F/F (Bit 2):

This bit indicates the complement of latched WE# output pin.

### DSD# (Bit 1):

- 0 Drive D has been selected
- 1 Drive D has not been selected

### DSC# (Bit 0):

- 0 Drive C has been selected
- 1 Drive C has not been selected

### 3.2.3 Digital Output Register (DO Register) (Write base address + 2)

The Digital Output Register is a write-only register controlling drive motors, drive selection, DRQ/IRQ enable, and FDC resetting. All the bits in this register are cleared by the MR pin. The bit definitions are as follows:

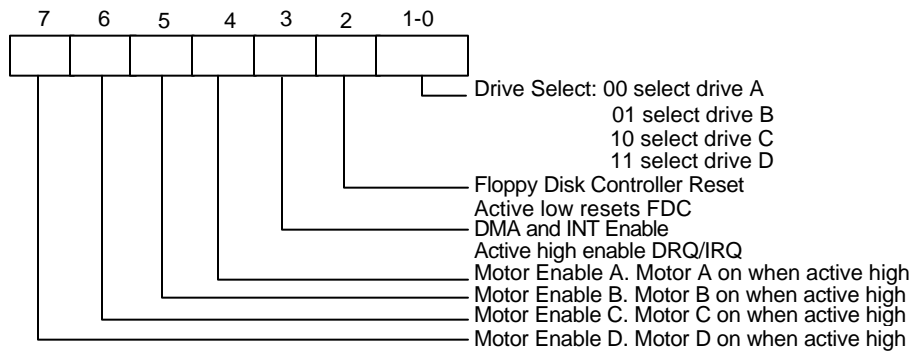

### 3.2.4 Tape Drive Register (TD Register) (Read base address + 3)

This register is used to assign a particular drive number to the tape drive support mode of the data separator. This register also holds the media ID, drive type, and floppy boot drive information of the floppy disk drive. In normal floppy mode, this register includes only bit 0 and 1. The bit definitions are as follows:

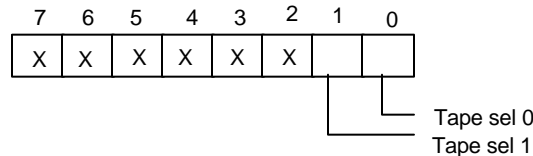

If three mode FDD function is enabled (EN3MODE = 1 in CR9), the bit definitions are as follows:

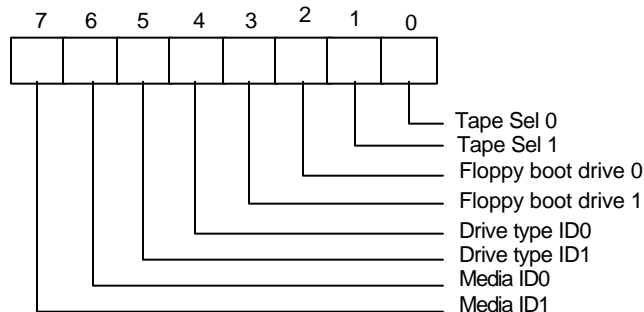

Media ID1 Media ID0 (Bit 7, 6):

These two bits are read only. These two bits reflect the value of CR8 bit 3, 2.

Drive type ID1 Drive type ID0 (Bit 5, 4):

These two bits reflect two of the bits of CR7. Which two bits are reflected depends on the last drive selected in the DO REGISTER.

Floppy Boot drive 1, 0 (Bit 3, 2):

These two bits reflect the value of CR8 bit 1, 0.

Tape Sel 1, Tape Sel 0 (Bit 1, 0):

These two bits assign a logical drive number to the tape drive. Drive 0 is not available as a tape drive and is reserved as the floppy disk boot drive.

TAPE SEL 1	TAPE SEL 0	DRIVE SELECTED
0	0	None
0	1	1
1	0	2
1	1	3

### 3.2.5 Main Status Register (MS Register) (Read base address + 4)

The Main Status Register is used to control the flow of data between the microprocessor and the controller. The bit definitions for this register are as follows:

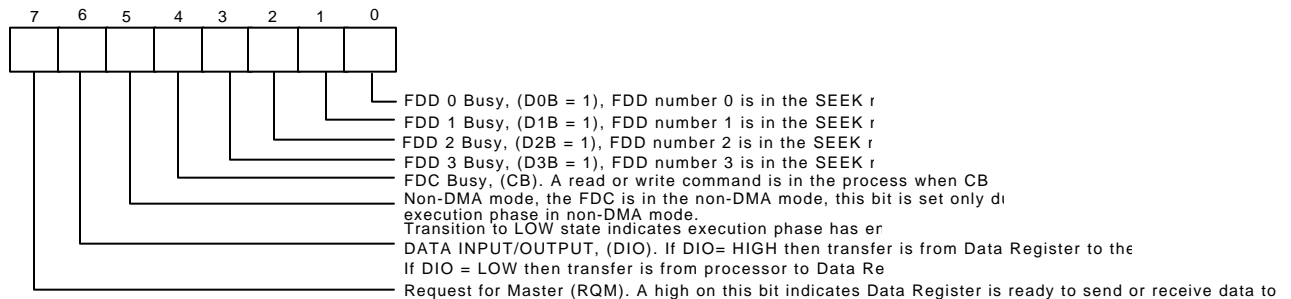

### 3.2.6 Data Rate Register (DR Register) (Write base address + 4)

The Data Rate Register is used to set the transfer rate and write precompensation. The data rate of the FDC is programmed by the CC REGISTER for PC-AT and PS/2 Model 30 and PS/2 mode, and not by the DR REGISTER. The real data rate is determined by the most recent write to either of the DR REGISTER or CC REGISTER.



**PRELIMINARY**

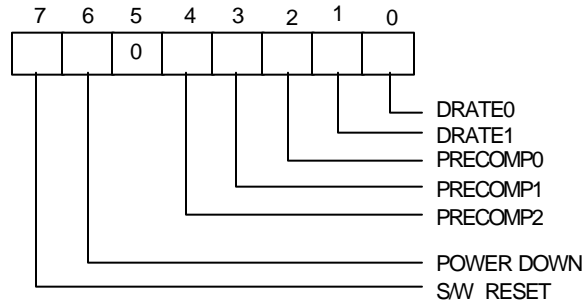

**S/W RESET (Bit 7):**

This bit is the software reset bit.

**POWER-DOWN (Bit 6):**

- 0 FDC in normal mode
- 1 FDC in power-down mode

**PRECOMP2 PRECOMP1 PRECOMP0 (Bit 4, 3, 2):**

These three bits select the value of write precompensation. The following tables show the precompensation values for the combination of these bits.

PRECOMP 2 1 0	PRECOMPENSATION DELAY	
	250K - 1 Mbps	2 Mbps Tape drive
0 0 0	Default Delays	Default Delays
0 0 1	41.67 nS	20.8 nS
0 1 0	83.34 nS	41.17 nS
0 1 1	125.00 nS	62.5nS
1 0 0	166.67 nS	83.3 nS
1 0 1	208.33 nS	104.2 nS
1 1 0	250.00 nS	125.00 nS
1 1 1	0.00 nS (disabled)	0.00 nS (disabled)

DATA RATE	DEFAULT PRECOMPENSATION DELAYS
250 KB/S	125 nS
300 KB/S	125 nS
500 KB/S	125 nS
1 MB/S	41.67nS
2 MB/S	20.8 nS

DRATE1 DRATE0 (Bit 1, 0):

These two bits select the data rate of the FDC and reduced write current control.

00	500 KB/S (MFM), 250 KB/S (FM), $\overline{\text{RWC}} = 1$
01	300 KB/S (MFM), 150 KB/S (FM), $\overline{\text{RWC}} = 0$
10	250 KB/S (MFM), 125 KB/S (FM), $\overline{\text{RWC}} = 0$
11	1 MB/S (MFM), Illegal (FM), $\overline{\text{RWC}} = 1$

The 2 MB/S data rate for Tape drive is only supported by setting 01 to DRATE1 and DRATE0 bits, as well as setting 10 to DRT1 and DRT0 bits which are two of the Configure Register CRF4 or CRF5 bits in logic device 0. Please refer to the function description of CRF4 or CRF5 and data rate table for individual data rates setting.

### 3.2.7 FIFO Register (R/W base address + 5)

The Data Register consists of four status registers in a stack with only one register presented to the data bus at a time. This register stores data, commands, and parameters and provides diskette-drive status information. Data bytes are passed through the data register to program or obtain results after a command. In the W83627SF, this register defaults to FIFO disabled mode after reset. The FIFO can change its value and enable its operation through the CONFIGURE command.

#### Status Register 0 (ST0)

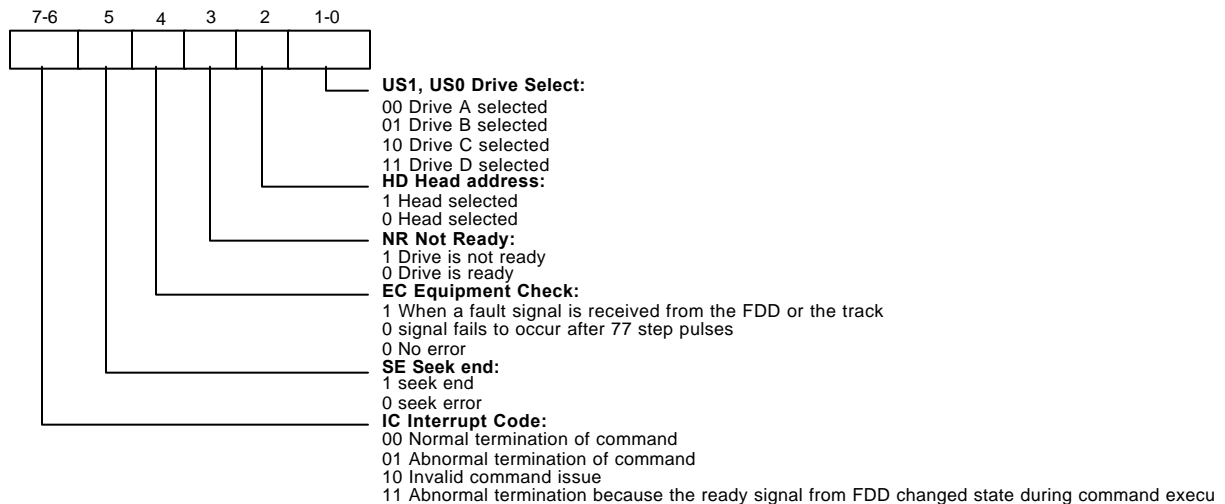

## Status Register 1 (ST1)

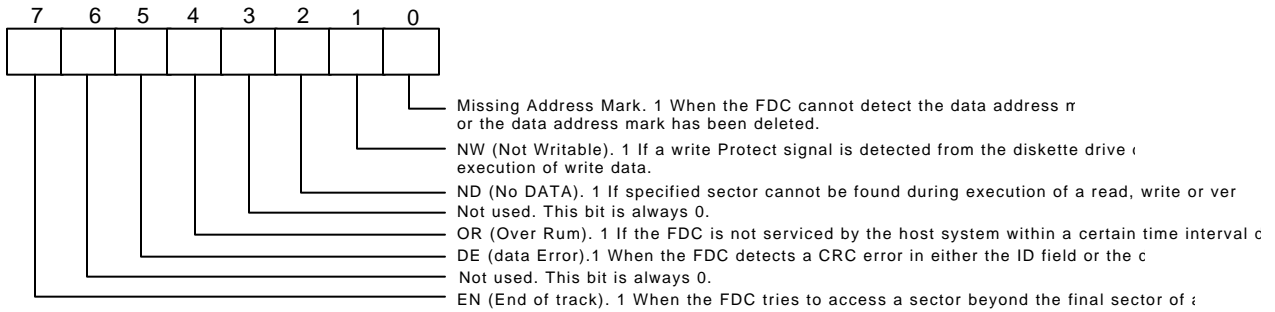

## Status Register 2 (ST2)

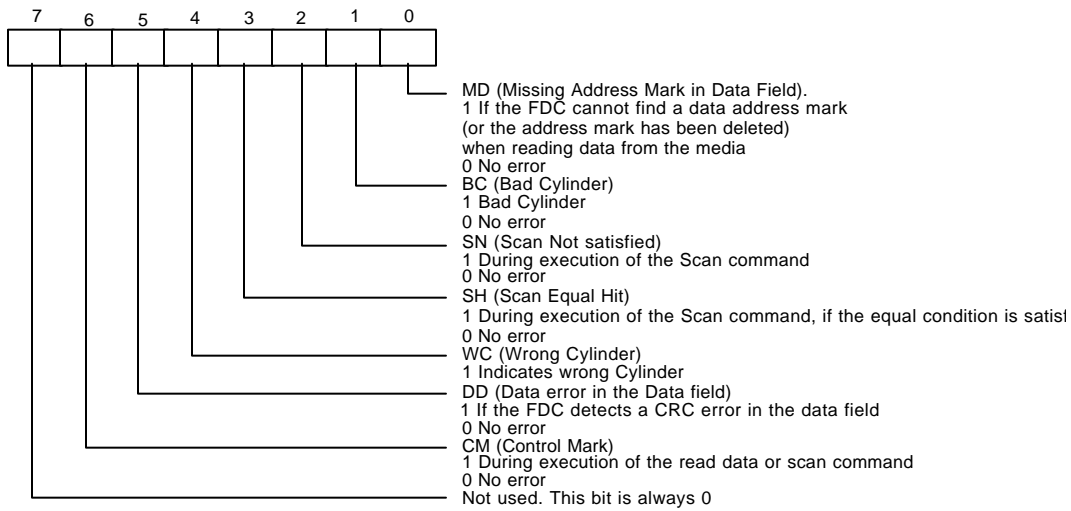

## Status Register 3 (ST3)

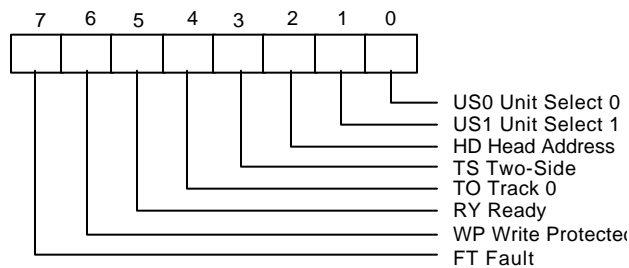

### 3.2.8 Digital Input Register (DI Register) (Read base address + 7)

The Digital Input Register is an 8-bit read-only register used for diagnostic purposes. In a PC/XT or AT only Bit 7 is checked by the BIOS. When the register is read, Bit 7 shows the complement of DSKCHG#, while other bits of the data bus remain in tri-state. Bit definitions are as follows:

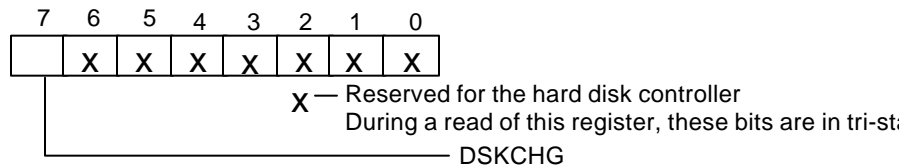

In the PS/2 mode, the bit definitions are as follows:

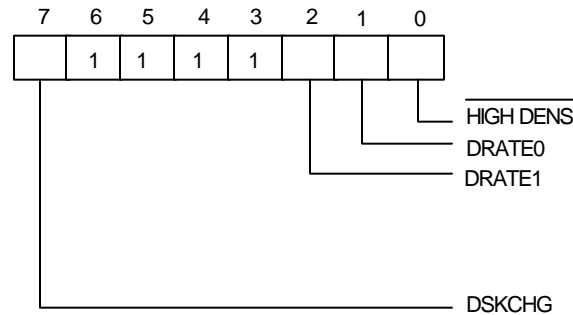

#### DSKCHG (Bit 7):

This bit indicates the complement of the DSKCHG# input.

Bit 6-3: These bits are always a logic 1 during a read.

#### DRATE1 DRATE0 (Bit 2, 1):

These two bits select the data rate of the FDC. Refer to the DR register bits 1 and 0 for the settings corresponding to the individual data rates.

#### HIGH DENS# (Bit 0):

0 500 KB/S or 1 MB/S data rate (high density FDD)

1 250 KB/S or 300 KB/S data rate

In the PS/2 Model 30 mode, the bit definitions are as follows:

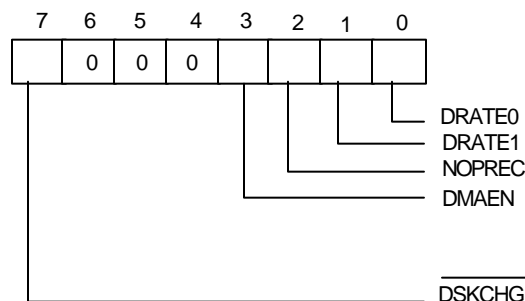

DSKCHG (Bit 7):

This bit indicates the status of DSKCHG# input.

Bit 6-4: These bits are always a logic 1 during a read.

DMAEN (Bit 3):

This bit indicates the value of DO REGISTER bit 3.

NOPREC (Bit 2):

This bit indicates the value of CC REGISTER NOPREC bit.

DRATE1 DRATE0 (Bit 1, 0):

These two bits select the data rate of the FDC.

### 3.2.9 Configuration Control Register (CC Register) (Write base address + 7)

This register is used to control the data rate. In the PC/AT and PS/2 mode, the bit definitions are as follows:

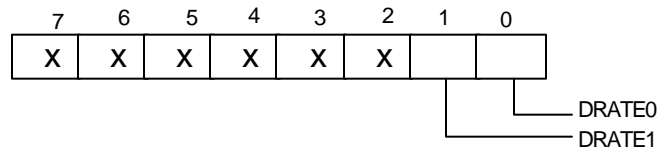

X: Reserved

Bit 7-2: Reserved. These bits should be set to 0.

DRATE1 DRATE0 (Bit 1, 0):

These two bits select the data rate of the FDC.

In the PS/2 Model 30 mode, the bit definitions are as follows:

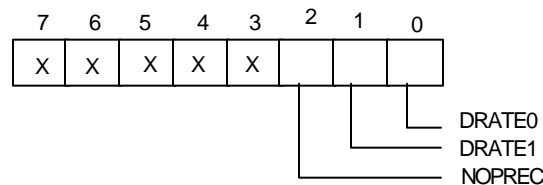

X: Reserved

Bit 7-3: Reserved. These bits should be set to 0.

NOPREC (Bit 2):

This bit indicates no precompensation. It has no function and can be set by software.

DRATE1 DRATE0 (Bit 1, 0):

These two bits select the data rate of the FDC.

## 4. UART PORT

### 4.1 Universal Asynchronous Receiver/Transmitter (UART A, UART B)

The UARTs are used to convert parallel data into serial format on the transmit side and convert serial data to parallel format on the receiver side. The serial format, in order of transmission and reception, is a start bit, followed by five to eight data bits, a parity bit (if programmed) and one, one and half (five-bit format only) or two stop bits. The UARTs are capable of handling divisors of 1 to 65535 and producing a 16x clock for driving the internal transmitter logic. Provisions are also included to use this 16x clock to drive the receiver logic. The UARTs also support the MIDI data rate. Furthermore, the UARTs also include complete modem control capability and a processor interrupt system that may be software trailed to the computing time required to handle the communication link. The UARTs have a FIFO mode to reduce the number of interrupts presented to the CPU. In each UART, there are 16-byte FIFOs for both receive and transmit mode.

### 4.2 Register Address

#### 4.2.1 UART Control Register (UCR) (Read/Write)

The UART Control Register controls and defines the protocol for asynchronous data communications, including data length, stop bit, parity, and baud rate selection.

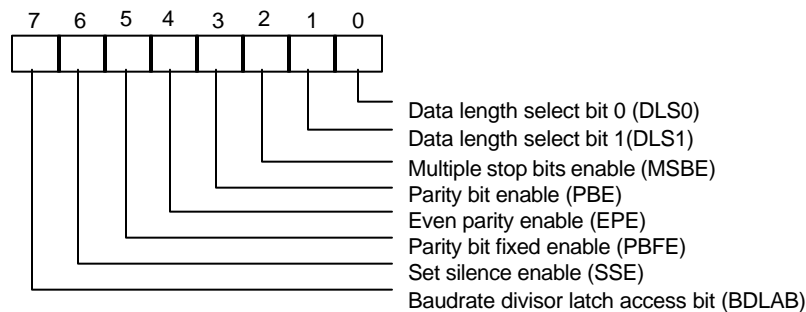

Bit 7: BDLAB. When this bit is set to a logical 1, designers can access the divisor (in 16-bit binary format) from the divisor latches of the baudrate generator during a read or write operation. When this bit is reset, the Receiver Buffer Register, the Transmitter Buffer Register, or the Interrupt Control Register can be accessed.

Bit 6: SSE. A logical 1 forces the Serial Output (SOUT) to a silent state (a logical 0). Only IRTX is affected by this bit; the transmitter is not affected.

Bit 5: PBFE. When PBE and PBFE of UCR are both set to a logical 1,

- (1) if EPE is logical 1, the parity bit is fixed as logical 0 to transmit and check.
- (2) if EPE is logical 0, the parity bit is fixed as logical 1 to transmit and check.



**PRELIMINARY**

TABLE 4-1 UART Register Bit Map

		Bit Number								
Register Address Base		0	1	2	3	4	5	6	7	
+ 0 BDLAB = 0	Receiver Buffer Register (Read Only)	RBR	RX Data Bit 0	RX Data Bit 1	RX Data Bit 2	RX Data Bit 3	RX Data Bit 4	RX Data Bit 5	RX Data Bit 6	RX Data Bit 7
+ 0 BDLAB = 0	Transmitter Buffer Register (Write Only)	TBR	TX Data Bit 0	TX Data Bit 1	TX Data Bit 2	TX Data Bit 3	TX Data Bit 4	TX Data Bit 5	TX Data Bit 6	TX Data Bit 7
+ 1 BDLAB = 0	Interrupt Control Register	ICR	RBR Data Ready Interrupt Enable (ERDRI)	TBR Empty Interrupt Enable (ETBREI)	USR Interrupt Enable (EUSRI)	HSR Interrupt Enable (EHSRI)	0	0	0	0
+ 2	Interrupt Status Register (Read Only)	ISR	"0" if Interrupt Pending	Interrupt Status Bit (0)	Interrupt Status Bit (1)	Interrupt Status Bit (2)**	0	0	FIFOs Enabled **	FIFOs Enabled **
+ 2	UART FIFO Control Register (Write Only)	UFR	FIFO Enable	RCVR FIFO Reset	XMIT FIFO Reset	DMA Mode Select	Reserved	Reversed	RX Interrupt Active Level (LSB)	RX Interrupt Active Level (MSB)
+ 3	UART Control Register	UCR	Data Length Select Bit 0 (DLS0)	Data Length Select Bit 1 (DLS1)	Multiple Stop Bits Enable (MSBE)	Parity Bit Enable (PBE)	Even Parity Enable (EPE)	Parity Bit Fixed Enable (PBFE)	Set Silence Enable (SSE)	Baudrate Divisor Latch Access Bit (BDLAB)
+ 4	Handshake Control Register	HCR	Data Terminal Ready (DTR)	Request to Send (RTS)	Loopback RI Input	IRQ Enable	Internal Loopback Enable	0	0	0
+ 5	UART Status Register	USR	RBR Data Ready (RDR)	Overrun Error (OER)	Parity Bit Error (PBER)	No Stop Bit Error (NSER)	Silent Byte Detected (SBD)	TBR Empty (TBRE)	TSR Empty (TSRE)	RX FIFO Error Indication (RFEI) **
+ 6	Handshake Status Register	HSR	CTS Toggling (TCTS)	DSR Toggling (TDSR)	RI Falling Edge (FERI)	DCD Toggling (TDCD)	Clear to Send (CTS)	Data Set Ready (DSR)	Ring Indicator (RI)	Data Carrier Detect (DCD)
+ 7	User Defined Register	UDR	Bit 0	Bit 1	Bit 2	Bit 3	Bit 4	Bit 5	Bit 6	Bit 7
+ 0 BDLAB = 1	Baudrate Divisor Latch Low	BLL	Bit 0	Bit 1	Bit 2	Bit 3	Bit 4	Bit 5	Bit 6	Bit 7
+ 1 BDLAB = 1	Baudrate Divisor Latch High	BHL	Bit 8	Bit 9	Bit 10	Bit 11	Bit 12	Bit 13	Bit 14	Bit 15

\*: Bit 0 is the least significant bit. The least significant bit is the first bit serially transmitted or received.

\*\* : These bits are always 0 in 16450 Mode.



## PRELIMINARY

Bit 4: EPE. This bit describes the number of logic 1's in the data word bits and parity bit only when bit 3 is programmed. When this bit is set, an even number of logic 1's are sent or checked. When the bit is reset, an odd number of logic 1's are sent or checked.

Bit 3: PBE. When this bit is set, the position between the last data bit and the stop bit of the SOUT will be stuffed with the parity bit at the transmitter. For the receiver, the parity bit in the same position as the transmitter will be detected.

Bit 2: MSBE. This bit defines the number of stop bits in each serial character that is transmitted or received.

- (1) If MSBE is set to a logical 0, one stop bit is sent and checked.
- (2) If MSBE is set to a logical 1, and data length is 5 bits, one and a half stop bits are sent and checked.
- (3) If MSBE is set to a logical 1, and data length is 6, 7, or 8 bits, two stop bits are sent and checked.

Bits 0 and 1: DLS0, DLS1. These two bits define the number of data bits that are sent or checked in each serial character.

TABLE 4-2 WORD LENGTH DEFINITION

DLS1	DLS0	DATA LENGTH
0	0	5 bits
0	1	6 bits
1	0	7 bits
1	1	8 bits



## 4.2.2 UART Status Register (USR) (Read/Write)

This 8-bit register provides information about the status of the data transfer during communication.

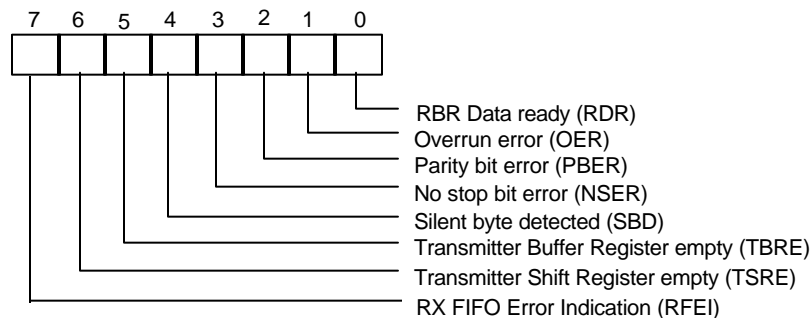

- Bit 7: RFEI. In 16450 mode, this bit is always set to a logic 0. In 16550 mode, this bit is set to a logic 1 when there is at least one parity bit error, no stop bit error or silent byte detected in the FIFO. In 16550 mode, this bit is cleared by reading from the USR if there are no remaining errors left in the FIFO.
- Bit 6: TSRE. In 16450 mode, when TBR and TSR are both empty, this bit will be set to a logical 1. In 16550 mode, if the transmit FIFO and TSR are both empty, it will be set to a logical 1. Other than these two cases, this bit will be reset to a logical 0.
- Bit 5: TBRE. In 16450 mode, when a data character is transferred from TBR to TSR, this bit will be set to a logical 1. If ETREI of ICR is a logical 1, an interrupt will be generated to notify the CPU to write the next data. In 16550 mode, this bit will be set to a logical 1 when the transmit FIFO is empty. It will be reset to a logical 0 when the CPU writes data into TBR or FIFO.
- Bit 4: SBD. This bit is set to a logical 1 to indicate that received data are kept in silent state for a full word time, including start bit, data bits, parity bit, and stop bits. In 16550 mode, it indicates the same condition for the data on top of the FIFO. When the CPU reads USR, it will clear this bit to a logical 0.
- Bit 3: NSER. This bit is set to a logical 1 to indicate that the received data have no stop bit. In 16550 mode, it indicates the same condition for the data on top of the FIFO. When the CPU reads USR, it will clear this bit to a logical 0.
- Bit 2: PBER. This bit is set to a logical 1 to indicate that the parity bit of received data is wrong. In 16550 mode, it indicates the same condition for the data on top of the FIFO. When the CPU reads USR, it will clear this bit to a logical 0.
- Bit 1: OER. This bit is set to a logical 1 to indicate received data have been overwritten by the next received data before they were read by the CPU. In 16550 mode, it indicates the same condition instead of FIFO full. When the CPU reads USR, it will clear this bit to a logical 0.
- Bit 0: RDR. This bit is set to a logical 1 to indicate received data are ready to be read by the CPU in the RBR or FIFO. After no data are left in the RBR or FIFO, the bit will be reset to a logical 0.

### 4.2.3 Handshake Control Register (HCR) (Read/Write)

This register controls the pins of the UART used for handshaking peripherals such as modem, and controls the diagnostic mode of the UART.

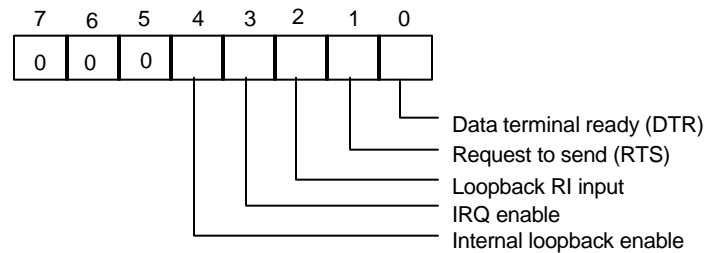

Bit 4: When this bit is set to a logical 1, the UART enters diagnostic mode by an internal loopback, as follows:

- (1) SOUT is forced to logical 1, and SIN is isolated from the communication link instead of the TSR.
- (2) Modem output pins are set to their inactive state.
- (3) Modem input pins are isolated from the communication link and connect internally as DTR (bit 0 of HCR) →  $\overline{DSR}$ , RTS (bit 1 of HCR) →  $\overline{CTS}$ , Loopback RI input (bit 2 of HCR) →  $\overline{RI}$  and IRQ enable (bit 3 of HCR) →  $\overline{DCD}$ .

Aside from the above connections, the UART operates normally. This method allows the CPU to test the UART in a convenient way.

Bit 3: The UART interrupt output is enabled by setting this bit to a logic 1. In the diagnostic mode this bit is internally connected to the modem control input  $\overline{DCD}$ .

Bit 2: This bit is used only in the diagnostic mode. In the diagnostic mode this bit is internally connected to the modem control input  $\overline{RI}$ .

Bit 1: This bit controls the  $\overline{RTS}$  output. The value of this bit is inverted and output to  $\overline{RTS}$ .

Bit 0: This bit controls the  $\overline{DTR}$  output. The value of this bit is inverted and output to  $\overline{DTR}$ .

### 4.2.4 Handshake Status Register (HSR) (Read/Write)

This register reflects the current state of four input pins for handshake peripherals such as a modem and records changes on these pins.

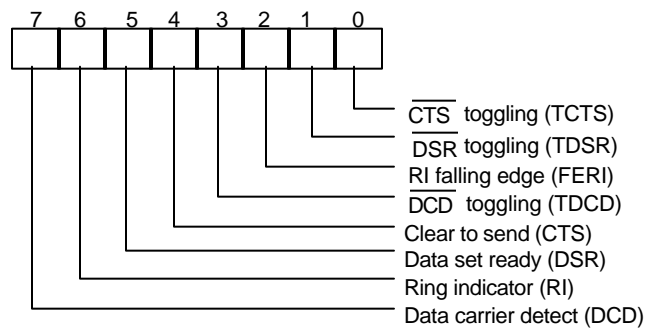

Bit 7: This bit is the opposite of the  $\overline{\text{DCD}}$  input. This bit is equivalent to bit 3 of HCR in loopback mode.

Bit 6: This bit is the opposite of the  $\overline{\text{RI}}$  input. This bit is equivalent to bit 2 of HCR in loopback mode.

Bit 5: This bit is the opposite of the  $\overline{\text{DSR}}$  input. This bit is equivalent to bit 0 of HCR in loopback mode.

Bit 4: This bit is the opposite of the  $\overline{\text{CTS}}$  input. This bit is equivalent to bit 1 of HCR in loopback mode.

Bit 3: TDCD. This bit indicates that the  $\overline{\text{DCD}}$  pin has changed state after HSR was read by the CPU.

Bit 2: FERI. This bit indicates that the  $\overline{\text{RI}}$  pin has changed from low to high state after HSR was read by the CPU.

Bit 1: TDSR. This bit indicates that the  $\overline{\text{DSR}}$  pin has changed state after HSR was read by the CPU.

Bit 0: TCTS. This bit indicates that the  $\overline{\text{CTS}}$  pin has changed state after HSR was read.

**4.2.5 UART FIFO Control Register (UFR) (Write only)**

This register is used to control the FIFO functions of the UART.

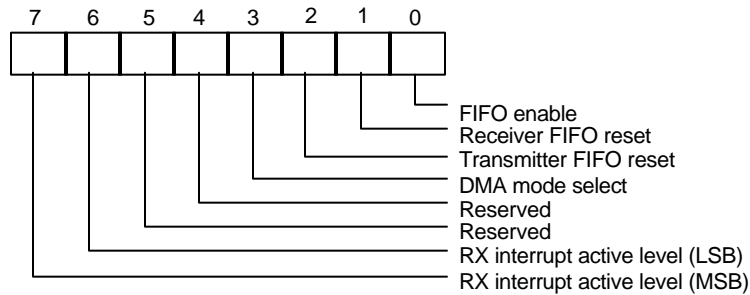

Bit 6, 7: These two bits are used to set the active level for the receiver FIFO interrupt. For example, if the interrupt active level is set as 4 bytes, once there are more than 4 data characters in the receiver FIFO, the interrupt will be activated to notify the CPU to read the data from the FIFO.

TABLE 4-3 FIFO TRIGGER LEVEL

BIT 7	BIT 6	RX FIFO INTERRUPT ACTIVE LEVEL (BYTES)
0	0	01
0	1	04
1	0	08
1	1	14

Bit 4, 5: Reserved

Bit 3: When this bit is programmed to logic 1, the DMA mode will change from mode 0 to mode 1 if UFR bit 0 = 1.

Bit 2: Setting this bit to a logical 1 resets the TX FIFO counter logic to initial state. This bit will clear to a logical 0 by itself after being set to a logical 1.

Bit 1: Setting this bit to a logical 1 resets the RX FIFO counter logic to initial state. This bit will clear to a logical 0 by itself after being set to a logical 1.

Bit 0: This bit enables the 16550 (FIFO) mode of the UART. This bit should be set to a logical 1 before other bits of UFR are programmed.

### 4.2.6 Interrupt Status Register (ISR) (Read only)

This register reflects the UART interrupt status, which is encoded by different interrupt sources into 3 bits.

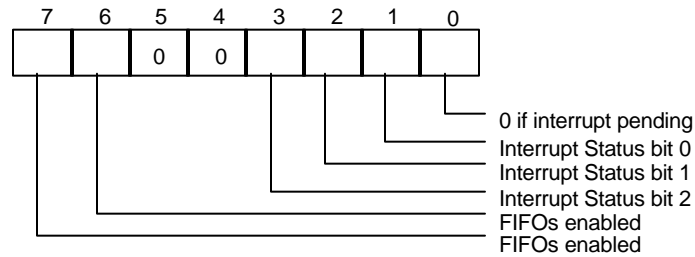

Bit 7, 6: These two bits are set to a logical 1 when UFR bit 0 = 1.

Bit 5, 4: These two bits are always logic 0.

Bit 3: In 16450 mode, this bit is 0. In 16550 mode, both bit 3 and 2 are set to a logical 1 when a time-out interrupt is pending.

Bit 2, 1: These two bits identify the priority level of the pending interrupt, as shown in the table below.

Bit 0: This bit is a logical 1 if there is no interrupt pending. If one of the interrupt sources has occurred, this bit will be set to a logical 0.

TABLE 4-4 INTERRUPT CONTROL FUNCTION

ISR				INTERRUPT SET AND FUNCTION			
Bit 3	Bit 2	Bit 1	Bit 0	Interrupt priority	Interrupt Type	Interrupt Source	Clear Interrupt
0	0	0	1	-	-	No Interrupt pending	-
0	1	1	0	First	UART Receive Status	1. OER = 1 2. PBER = 1 3. NSER = 1 4. SBD = 1	Read USR
0	1	0	0	Second	RBR Data Ready	1. RBR data ready 2. FIFO interrupt active level reached	1. Read RBR 2. Read RBR until FIFO data under active level
1	1	0	0	Second	FIFO Data Timeout	Data present in RX FIFO for 4 characters period of time since last access of RX FIFO.	Read RBR
0	0	1	0	Third	TBR Empty	TBR empty	1. Write data into TBR 2. Read ISR (if priority is third)
0	0	0	0	Fourth	Handshake status	1. TCTS = 1 2. TDSR = 1 3. FER1 = 1 4. TDCD = 1	Read HSR

\*\* Bit 3 of ISR is enabled when bit 0 of UFR is logical 1.

### 4.2.7 Interrupt Control Register (ICR) (Read/Write)

This 8bit register allows the five types of controller interrupts to activate the interrupt output signal separately. The interrupt system can be totally disabled by resetting bits 0 through 3 of the Interrupt Control Register (ICR). A selected interrupt can be enabled by setting the appropriate bits of this register to a logical 1.

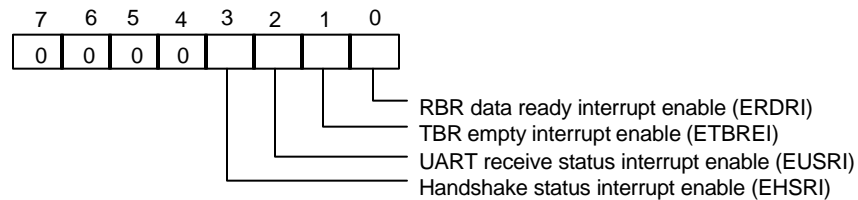

Bit 7-4: These four bits are always logic 0.

Bit 3: EHSRI. Setting this bit to a logical 1 enables the handshake status register interrupt.

Bit 2: EUSRI. Setting this bit to a logical 1 enables the UART status register interrupt.

Bit 1: ETBREI. Setting this bit to a logical 1 enables the TBR empty interrupt.

Bit 0: ERDRI. Setting this bit to a logical 1 enables the RBR data ready interrupt.

### 4.2.8 Programmable Baud Generator (BLL/BHL) (Read/Write)

Two 8-bit registers, BLL and BHL, compose a programmable baud generator that uses 24 MHz to generate a 1.8461 MHz frequency and divides it by a divisor from 1 to  $2^{16} - 1$ . The output frequency of the baud generator is the baud rate multiplied by 16, and this is the base frequency for the transmitter and receiver. The table in the next page illustrates the use of the baud generator with a frequency of 1.8461 MHz. In high-speed UART mode (refer to CR0C bit7 and CR0C bit6), the programmable baud generator directly uses 24 MHz and the same divisor as the normal speed divisor. In high-speed mode, the data transmission rate can be as high as 1.5M bps.



**PRELIMINARY**

### 4.2.9 User-defined Register (UDR) (Read/Write)

This is a temporary register that can be accessed and defined by the user.

TABLE 4-5 BAUD RATE TABLE

BAUD RATE FROM DIFFERENT PRE-DIVIDER				
Pre-Div: 13 1.8461M Hz	Pre-Div:1.625 14.769M Hz	Pre-Div: 1.0 24M Hz	Decimal divisor used to generate 16X clock	Error Percentage between desired and actual
50	400	650	<b>2304</b>	**
75	600	975	<b>1536</b>	**
110	880	1430	<b>1047</b>	0.18%
134.5	1076	1478.5	<b>857</b>	0.099%
150	1200	1950	<b>768</b>	**
300	2400	3900	<b>384</b>	**
600	4800	7800	<b>192</b>	**
1200	9600	15600	<b>96</b>	**
1800	14400	23400	<b>64</b>	**
2000	16000	26000	<b>58</b>	0.53%
2400	19200	31200	<b>48</b>	**
3600	28800	46800	<b>32</b>	**
4800	38400	62400	<b>24</b>	**
7200	57600	93600	<b>16</b>	**
9600	76800	124800	<b>12</b>	**
19200	153600	249600	<b>6</b>	**
38400	307200	499200	<b>3</b>	**
57600	460800	748800	<b>2</b>	**
115200	921600	1497600	<b>1</b>	**

\*\* The percentage error for all baud rates, except where indicated otherwise, is 0.16%.

Note. Pre-Divisor is determined by CRF0 of UART A and B.

## 5. CIR RECEIVER PORT

### 5.1 CIR Registers

#### 5.1.1 Bank0.Reg0 - Receiver Buffer Registers (RBR) (Read)

Receiver Buffer Register is read only. When the CIR pulse train has been detected and passed by the internal signal filter, the data sampled and shifted into shifter register will write into Receiver Buffer Register. In the CIR, this port is only supports PIO mode and the address port is defined in the PnP.

#### 5.1.2 Bank0.Reg1 - Interrupt Control Register (ICR)

Power on default <7:0> = 00000000 binary

Bit	Name	Read/Write	Description
7	EN_GLBI	Read/Write	Enable Global Interrupt. Write 1, enable interrupt. Write 0, disable global interrupt.
6-3	Reserved	-	Reserved
2	EN_TMR_I	Read/Write	Enable Timer Interrupt.
1	En_LSR_I	Read/Write	Enable Line-Status-Register interrupt.
0	EN_RX_I	Read/Write	Receiver Thershold-Level Interrupt Enable.

#### 5.1.3 Bank0.Reg2 - Interrupt Status Register (ISR)

Power on default <7:0> = 00000000 binary

Bit	Name	Read/Write	Description
7-3	Reserved		Reserved
2	TMR_I	Read Only	Timer Interrupt. Set to 1 when timer count to 0. This bit will be affected by (1) the timer registers are defined in Bank4.Reg0 and Bank1.Reg0~1, (2) EN_TMR(Enable Timer, in Bank0.Reg3.Bit2) should be set to 1, (3) ENTMR_I (Enable Timer Interrupt, in Bank0.Reg1.Bit2) should be set to 1.
1	LSR_I	Read Only	Line-Status-Register interrupt. Set to 1 when overrun, or parity bit, or stop bit, or silent byte detected error in the Line Status Register (LSR) sets to 1. Clear to 0 when LSR is read.
0	RXTH_I	Read Only	Receiver Thershold-Level Interrupt. Set to 1 when (1) the Receiver Buffer Register (RBR) is equal or larger than the threshold level, (2) RBR occurs time-out if the receiver buffer register has valid data and below the threshold level. Clear to 0 when RBR is less than threshold level from reading RBR.



#### 5.1.4 Bank0~3.Reg3 - CIR Control Register 0/Bank Select Register (CTR0/BSR) (BANK0~3)

Power on default <7:0> = 00000000 binary

Bit	Name	Read/Write	Description
7-6	BNK_SEL<1:0>	Read/Write	Bank Select Register. These two bits are shared same address so that <i>Bank Select Register (BSR)</i> can be programmed to desired Bank in any Bank. BNK_SEL<1:0> = 00 Select Bank 0. BNK_SEL<1:0> = 01 Select Bank 1. BNK_SEL<1:0> = Reserved. BNK_SEL<1:0> = Reserved.
5-4	RXFTL1/0	Read/Write	Receiver FIFO Threshold Level. It is to determine the RXTH_I to become 1 when the Receiver FIFO Threshold Level is equal or larger than the defined value shown as follow. RXFTL<1:0> = 00 -- 1 byte RXFTL<1:0> = 01 -- 4 bytes RXFTL<1:0> = 10 -- 8 bytes RXFTL<1:0> = 11 -- 14 bytes
3	TMR_TST	Read/Write	Timer Test. Write to 1, then reading the TMRL/TMRH will return the programmed values of TMRL/TMRH, that is, does not return down count counter value. This bit is for test timer register.
2	EN_TMR	Read/Write	Enable timer. Write to 1, enable the timer
1	RXF_RST	Read/Write	Setting this bit to a logical 1 resets the RX FIFO counter logic to initial state. This bit will clear to a logical 0 by itself after being set to a logical 1.
0	TMR_CLK	Read/Write	Timer input clock. Winbond test register

#### 5.1.5 Bank0.Reg4 - CIR Control Register (CTR)

Power on default <7:0> = 0010,1001 binary

Bit	Name	Read/Write	Description
7-5	RX_FR<2:0>	Read/Write	Receiver Frequency Range 2~0. These bits select the input frequency of the receiver ranges. For the input signal, that is through a band pass filter, i.e., the frequency of the input signal is located at this defined range then the signal will be received.
4-0	RX_FSL<4:0>	Read/Write	Receiver Frequency Select 4~0. Select the receiver operation frequency.

Table: Low Frequency range select of receiver.

RX_FSL4~0	RX_FR2~0 (Low Frequency)					
	001		010		011	
	Min.	Max.	Min.	Max.	Min.	Max.
00010	26.1	29.6	24.7	31.7	23.4	34.2
00011	28.2	32.0	26.7	34.3	25.3	36.9
00100	29.4	33.3	27.8	35.7	26.3	38.4
00101	30.0	34.0	28.4	36.5	26.9	39.3
00110	31.4	35.6	29.6	38.1	28.1	41.0
00111	32.1	36.4	30.3	39.0	28.7	42.0
01000	32.8	37.2	31.0	39.8	29.4	42.9
01001	<b>33.6*</b>	<b>38.1*</b>	31.7	40.8	30.1	44.0
01011	34.4	39.0	32.5	41.8	30.8	45.0
01100	36.2	41.0	34.2	44.0	32.4	47.3
01101	37.2	42.1	35.1	45.1	33.2	48.6
01111	38.2	43.2	36.0	46.3	34.1	49.9
10000	40.3	45.7	38.1	49.0	36.1	52.7
10010	41.5	47.1	39.2	50.4	37.2	54.3
10011	42.8	48.5	40.4	51.9	38.3	56.0
10101	44.1	50.0	41.7	53.6	39.5	57.7
10111	45.5	51.6	43.0	55.3	40.7	59.6
11010	48.7	55.2	46.0	59.1	43.6	63.7
11011	50.4	57.1	47.6	61.2	45.1	65.9
11101	54.3	61.5	51.3	65.9	48.6	71.0

Note that the other non-defined values are reserved.

### 5.1.6 Bank0.Reg5 - UART Line Status Register (USR)

Power on default <7:0> = 0000,0000 binary

Bit	Name	Read/Write	Description
7-3	Reserved	-	-
2	RX_TO	Read/Write	Set to 1 when receiver FIFO or frame status FIFO occurs time-out. Read this bit will be cleared.
1	OV_ERR	Read/Write	Received FIFO overrun. Read to clear.
0	RDR	Read/Write	This bit is set to a logical 1 to indicate received data are ready to be read by the CPU in the RBR or FIFO. After no data are left in the RBR or FIFO, the bit will be reset to a logical 0.



PRELIMINARY

5.1.7 Bank0.Reg6 - Remote Infrared Config Register (RIR\_CFG)

Power on default <7:0> = 0000,0000 binary

Bit	Name	Read/Write	Description
7-6	SMPSEL<1:0>	Read/Write	<p>Sampling Mode Select. Select internal decoder methodology from the internal filter. Selected decoder mode will determine the receive data format. The sampling mode is shown as below:                      SMPSEL&lt;1:0&gt; = 00 T-Period Sample Mode.                      SMPSEL&lt;1:0&gt; = 01 Over-Sampling Mode.                      SMPSEL&lt;1:0&gt; = 10 Over-Sampling with re-sync.                      SMPSEL&lt;1:0&gt; = 11 FIFO Test Mode.                      The T-period code format is defined as follows.</p> <div style="text-align: center;"> <p>(Number of bits) - 1</p> </div> <p>The Bit value is set to 0, then the high pulse will be received. The Bit value is set to 1, then no energy will be received. The opposite results will be generated when the bit RXINV (Bank0.Reg6.Bit0) is set to 1.</p>
5-4	LP_SL<1:0>	Read/Write	<p>Low pass filter source selction.                      LP_SL&lt;1:0&gt; = 00 Select raw IRRX signal.                      LP_SL&lt;1:0&gt; = 01 Select R.B.P. signal                      LP_SL&lt;1:0&gt; = 10 Select D.B.P. signal.                      LP_SL&lt;1:0&gt; = 11 Reserved.</p>
3-2	RXDMSL<1:0>	Read/Write	<p>Receiver Demodulation Source Selection.                      RXDMSL&lt;1:0&gt; = 00 select B.P. and L.P. filter.                      RXDMSL&lt;1:0&gt; = 01 select B.P. but not L.P.                      RXDMSL&lt;1:0&gt; = 10 Reserved.                      RXDMSL&lt;1:0&gt; = 11 do not pass demodulation.</p>
1	PRE_DIV	Read/Write	<p>Baud Rate Pre-divisor. Set to 1, the baud rate generator input clock is set to 1.8432M Hz which is set to pre-divisor into 13. When set to 0, the pre-divisor is set to 1, that is, the input clock of baud rate generator is set to 24M Hz.</p>
0	RXINV	Read/Write	<p>Receiving Signal Invert. Write to 1, Invert the receiving signal.</p>



PRELIMINARY

### 5.1.8 Bank0.Reg7 - User Defined Register (UDR/AUDR)

Power on default <7:0> = 0000,0000 binary

Bit	Name	Read/Write	Description
7	RXACT	Read/Write	Receive Active. Set to 1 whenever a pulse or pulse-train is detected by the receiver. If a 1 is written into the bit position, the bit is cleared and the receiver is de-activated. When this bit is set, the receiver samples the IR input continuously at the programmed baud rate and transfers the data to the receiver FIFO.
6	RX_PD	Read Only	Set to 1 whenever a pulse or pulse-train (modulated pulse) is detected by the receiver. Can be used by the software to detect idle condition Cleared Upon Read.
5	Reserved	-	-
4-0	FOLVAL	Read Only	FIFO Level Value. Indicate that how many bytes are there in the current received FIFO. Can read these bits then get the FIFO level value and successively read RBR by the prior value.



PRELIMINARY

### 5.1.9 Bank1.Reg0~1 - Baud Rate Divisor Latch (BLL/BHL)

The two registers of BLL and BHL are baud rate divisor latch in the legacy UART/SIR/ASK-IR mode. Read/Write these registers, if set in Advanced UART mode, will occur backward operation, that is, will go to legacy UART mode and clear some register values shown table as follows.

TABLE :BAUD RATE TABLE

BAUD RATE USING 24 MHZ TO GENERATE 1.8461 MHZ		
Desired Baud Rate	Decimal divisor used to generate 16X clock	Percent error difference between desired and actual
50	2304	**
75	1536	**
110	1047	0.18%
134.5	857	0.099%
150	768	**
300	384	**
600	192	**
1200	96	**
1800	64	**
2000	58	0.53%
2400	48	**
3600	32	**
4800	24	**
7200	16	**
9600	12	**
19200	6	**
38400	3	**
57600	2	**
115200	1	**
1.5M	1 Note 1	0%

Note 1: Only use in high speed mode, when Bank0.Reg6.Bit7 is set.

\*\* The percentage error for all baud rates, except where indicated otherwise, is 0.16%

#### 5.1.10 Bank1.Reg2 - Version ID Register I (VID)

Power on default <7:0> = 0001,0000 binary

Bit	Name	Read/Write	Description
7-0	VID	Read Only	Version ID, default is set to 0x10.

#### 5.1.11 Bank0~3.Reg3 - CIR Control Register 0/Bank Select Register (CTR0/BSR) (BANK0~3)

This register is defined same as in Bank0.Reg3.

#### 5.1.12 Bank1.Reg4 - Timer Low Byte Register (TMRL)

Power on default <7:0> = 0000,0000 binary

Bit	Name	Read/Write	Description
7-0	TMRL	Read/Write	Timer Low Byte Register. This is a 12-bit timer (another 4-bit is defined in Bank1.Reg5) which resolution is 1 ms, that is, the programmed maximum time is $2^{12}-1$ ms. The timer is a down-counter. The timer start down count when the bit EN_TMR (Enable Timer) of Bank0.Reg2. is set to 1. When the timer down count to zero and EN_TMR=1, the TMR_I is set to 1. When the counter down count to zero, a new initial value will be re-loaded into timer counter.

#### 5.1.13 Bank1.Reg5 - Timer High Byte Register (TMRH)

Power on default <7:0> = 0000,0000 binary

Bit	Name	Read/Write	Description
7-4	Reserved		Reserved.
3-0	TMRH	Read/Write	Timer High Byte Register. See Bank1.Reg4.

## 6. PARALLEL PORT

### 6.1 Printer Interface Logic

The parallel port of the W83627SF makes possible the attachment of various devices that accept eight bits of parallel data at standard TTL level. The W83627SF supports an IBM XT/AT compatible parallel port (SPP), bi-directional parallel port (BPP), Enhanced Parallel Port (EPP), Extended Capabilities Parallel Port (ECP), Extension FDD mode (EXTFDD), Extension 2FDD mode (EXT2FDD) on the parallel port. Refer to the configuration registers for more information on disabling, power-down, and on selecting the mode of operation.

Table 6-1 shows the pin definitions for different modes of the parallel port.

**TABLE 6-1-1 PARALLEL PORT CONNECTOR AND PIN DEFINITIONS**

HOST CONNECTOR	PIN NUMBER OF W83627SF	PIN ATTRIBUTE	SPP	EPP	ECP
1	36	O	nSTB	nWrite	nSTB, HostClk <sup>2</sup>
2-9	31-26, 24-23	I/O	PD<0:7>	PD<0:7>	PD<0:7>
10	22	I	nACK	Intr	nACK, PeriphClk <sup>2</sup>
11	21	I	BUSY	nWait	BUSY, PeriphAck <sup>2</sup>
12	19	I	PE	PE	PEerror, nAckReverse <sup>2</sup>
13	18	I	SLCT	Select	SLCT, Xflag <sup>2</sup>
14	35	O	nAFD	nDStrb	nAFD, HostAck <sup>2</sup>
15	34	I	nERR	nError	nFault <sup>1</sup> , nPeriphRequest <sup>2</sup>
16	33	O	nINIT	nInit	nINIT <sup>1</sup> , nReverseRqst <sup>2</sup>
17	32	O	nSLIN	nAStrb	nSLIN <sup>1</sup> , ECPMode <sup>2</sup>

Notes:

n<name > : Active Low

1. Compatible Mode

2. High Speed Mode

3. For more information, refer to the IEEE 1284 standard.



**PRELIMINARY**

**TABLE 6-1-2** PARALLEL PORT CONNECTOR AND PIN DEFINITIONS

HOST CONNECTOR	PIN NUMBER OF W83627SF	PIN ATTRIBUTE	SPP	PIN ATTRIBUTE	EXT2FDD	PIN ATTRIBUTE	EXTFDD
1	36	O	nSTB	---	---	---	---
2	31	I/O	PD0	I	INDEX2#	I	INDEX2#
3	30	I/O	PD1	I	TRAK02#	I	TRAK02#
4	29	I/O	PD2	I	WP2#	I	WP2#
5	28	I/O	PD3	I	RDATA2#	I	RDATA2#
6	27	I/O	PD4	I	DSKCHG2#	I	DSKCHG2#
7	26	I/O	PD5	---	---	---	---
8	24	I/O	PD6	OD	MOA2#	---	---
9	23	I/O	PD7	OD	DSA2#	---	---
10	22	I	nACK	OD	DSB2#	OD	DSB2#
11	21	I	BUSY	OD	MOB2#	OD	MOB2#
12	19	I	PE	OD	WD2#	OD	WD2#
13	18	I	SLCT	OD	WE2#	OD	WE2#
14	35	O	nAFD	OD	RWC2#	OD	RWC2#
15	34	I	nERR	OD	HEAD2#	OD	HEAD2#
16	33	O	nINIT	OD	DIR2#	OD	DIR2#
17	32	O	nSLIN	OD	STEP2#	OD	STEP2#

## 6.2 Enhanced Parallel Port (EPP)

**TABLE 6-2** PRINTER MODE AND EPP REGISTER ADDRESS

A2	A1	A0	REGISTER	NOTE
0	0	0	Data port (R/W)	1
0	0	1	Printer status buffer (Read)	1
0	1	0	Printer control latch (Write)	1
0	1	0	Printer control swapper (Read)	1
0	1	1	EPP address port (R/W)	2
1	0	0	EPP data port 0 (R/W)	2
1	0	1	EPP data port 1 (R/W)	2
1	1	0	EPP data port 2 (R/W)	2
1	1	1	EPP data port 2 (R/W)	2

Notes:

1. These registers are available in all modes.
2. These registers are available only in EPP mode.



### 6.2.1 Data Swapper

The system microprocessor can read the contents of the printer's data latch by reading the data swapper.

### 6.2.2 Printer Status Buffer

The system microprocessor can read the printer status by reading the address of the printer status buffer. The bit definitions are as follows:

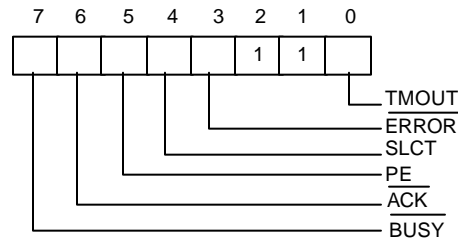

Bit 7: This signal is active during data entry, when the printer is off-line during printing, when the print head is changing position, or during an error state. When this signal is active, the printer is busy and cannot accept data.

Bit 6: This bit represents the current state of the printer's **ACK#** signal. A 0 means the printer has received a character and is ready to accept another. Normally, this signal will be active for approximately 5 microseconds before **BUSY#** stops.

Bit 5: Logical 1 means the printer has detected the end of paper.

Bit 4: Logical 1 means the printer is selected.

Bit 3: Logical 0 means the printer has encountered an error condition.

Bit 1, 2: These two bits are not implemented and are logic one during a read of the status register.

Bit 0: This bit is valid in EPP mode only. It indicates that a 10  $\mu$ S time-out has occurred on the EPP bus. A logic 0 means that no time-out error has occurred; a logic 1 means that a time-out error has been detected. Writing a logic 1 to this bit will clear the time-out status bit; writing a logic 0 has no effect.

### 6.2.3 Printer Control Latch and Printer Control Swapper

The system microprocessor can read the contents of the printer control latch by reading the printer control swapper. Bit definitions are as follows:

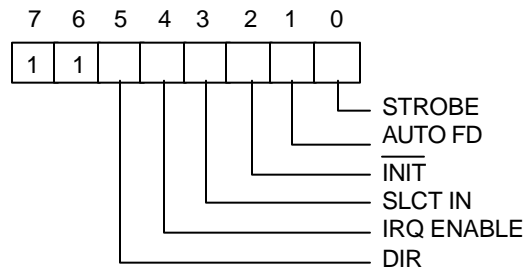

Bit 7, 6: These two bits are a logic one during a read. They can be written.

Bit 5: Direction control bit

When this bit is a logic 1, the parallel port is in input mode (read); when it is a logic 0, the parallel port is in output mode (write). This bit can be read and written. In SPP mode, this bit is invalid and fixed at zero.

Bit 4: A 1 in this position allows an interrupt to occur when ACK# changes from low to high.

Bit 3: A 1 in this bit position selects the printer.

Bit 2: A 0 starts the printer (50 microsecond pulse, minimum).

Bit 1: A 1 causes the printer to line-feed after a line is printed.

Bit 0: A 0.5 microsecond minimum high active pulse clocks data into the printer. Valid data must be present for a minimum of 0.5 microseconds before and after the strobe pulse.

### 6.2.4 EPP Address Port

The address port is available only in EPP mode. Bit definitions are as follows:

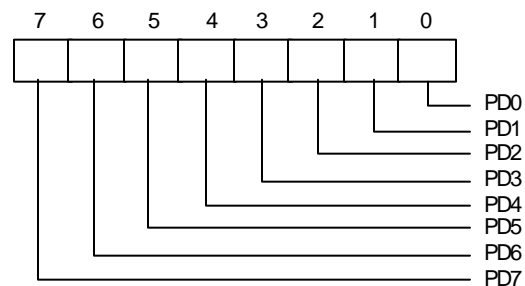

The contents of DB0-DB7 are buffered (non-inverting) and output to ports PD0-PD7 during a write operation. The leading edge of IOW# causes an EPP address write cycle to be performed, and the trailing edge of IOW# latches the data for the duration of the EPP write cycle.

PD0-PD7 ports are read during a read operation. The leading edge of IOR# causes an EPP address read cycle to be performed and the data to be output to the host CPU.

### 6.2.5 EPP Data Port 0-3

These four registers are available only in EPP mode. Bit definitions of each data port are as follows:

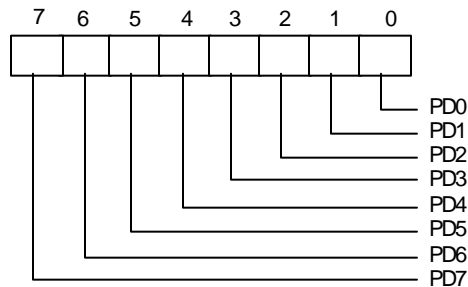

When accesses are made to any EPP data port, the contents of DB0-DB7 are buffered (non-inverting) and output to the ports PD0-PD7 during a write operation. The leading edge of IOW# causes an EPP data write cycle to be performed, and the trailing edge of IOW# latches the data for the duration of the EPP write cycle.

During a read operation, ports PD0-PD7 are read, and the leading edge of IOR# causes an EPP read cycle to be performed and the data to be output to the host CPU.

### 6.2.6 Bit Map of Parallel Port and EPP Registers

REGISTER	7	6	5	4	3	2	1	0
Data Port (R/W)	PD7	PD6	PD5	PD4	PD3	PD2	PD1	PD0
Status Buffer (Read)	BUSY#	ACK#	PE	SLCT	ERROF#	1	1	TMOUT
Control Swapper (Read)	1	1	1	IRQEN	SLIN	INIT#	AUTOFD#	STROBE#
Control Latch (Write)	1	1	DIR	IRQ	SLIN	INIT#	AUTOFD#	STROBE#
EPP Address Port R/W)	PD7	PD6	PD5	PD4	PD3	PD2	PD1	PD0
EPP Data Port 0 (R/W)	PD7	PD6	PD5	PD4	PD3	PD2	PD1	PD0
EPP Data Port 1 (R/W)	PD7	PD6	PD5	PD4	PD3	PD2	PD1	PD0
EPP Data Port 2 (R/W)	PD7	PD6	PD5	PD4	PD3	PD2	PD1	PD0
EPP Data Port 3 (R/W)	PD7	PD6	PD5	PD4	PD3	PD2	PD1	PD0

### 6.2.7 EPP Pin Descriptions

EPP NAME	TYPE	EPP DESCRIPTION
nWrite	O	Denotes an address or data read or write operation.
PD<0:7>	I/O	Bi-directional EPP address and data bus.
Intr	I	Used by peripheral device to interrupt the host.
nWait	I	Inactive to acknowledge that data transfer is completed. Active to indicate that the device is ready for the next transfer.
PE	I	Paper end; same as SPP mode.
Select	I	Printer selected status; same as SPP mode.
nDStrb	O	This signal is active low. It denotes a data read or write operation.
nError	I	Error; same as SPP mode.
nInits	O	This signal is active low. When it is active, the EPP device is reset to its initial operating mode.
nAStrb	O	This signal is active low. It denotes an address read or write operation.

### 6.2.8 EPP Operation

When the EPP mode is selected in the configuration register, the standard and bi-directional modes are also available. The PDx bus is in the standard or bi-directional mode when no EPP read, write, or address cycle is currently being executed. In this condition all output signals are set by the SPP Control Port and the direction is controlled by DIR of the Control Port.

A watchdog timer is required to prevent system lockup. The timer indicates that more than 10  $\mu$ S have elapsed from the start of the EPP cycle to the time WAIT# is deasserted. The current EPP cycle is aborted when a time-out occurs. The time-out condition is indicated in Status bit 0.

#### 6.2.8.1 EPP Operation

The EPP operates on a two-phase cycle. First, the host selects the register within the device for subsequent operations. Second, the host performs a series of read and/or write byte operations to the selected register. Four operations are supported on the EPP: Address Write, Data Write, Address Read, and Data Read. All operations on the EPP device are performed asynchronously.

#### 6.2.8.2 EPP Version 1.9 Operation

The EPP read/write operation can be completed under the following conditions:

- If the nWait is active low, when the read cycle (nWrite inactive high, nDStrb/nAStrb active low) or write cycle (nWrite active low, nDStrb/nAStrb active low) starts, the read/write cycle proceeds normally and will be completed when nWait goes inactive high.
- If nWait is inactive high, the read/write cycle will not start. It must wait until nWait changes to active low, at which time it will start as described above.

#### 6.2.8.3 EPP Version 1.7 Operation

The EPP read/write cycle can start without checking whether nWait is active or inactive. Once the read/write cycle starts, however, it will not terminate until nWait changes from active low to inactive high.



PRELIMINARY

### 6.3 Extended Capabilities Parallel (ECP) Port

This port is software and hardware compatible with existing parallel ports, so it may be used as a standard printer mode if ECP is not required. It provides an automatic high burst-bandwidth channel that supports DMA for ECP in both the forward (host to peripheral) and reverse (peripheral to host) directions. Small FIFOs are used in both forward and reverse directions to improve the maximum bandwidth requirement. The size of the FIFO is 16 bytes. The ECP port supports an automatic handshake for the standard parallel port to improve compatibility mode transfer speed.

The ECP port supports run-length-encoded (RLE) decompression (required) in hardware. Compression is accomplished by counting identical bytes and transmitting an RLE byte that indicates how many times the next byte is to be repeated. Hardware support for compression is optional.

For more information about the ECP Protocol, refer to the Extended Capabilities Port Protocol and ISA Interface Standard.

#### 6.3.1 ECP Register and Mode Definitions

NAME	ADDRESS	I/O	ECP MODES	FUNCTION
data	Base+000h	R/W	000-001	Data Register
ecpAFifo	Base+000h	R/W	011	ECP FIFO (Address)
dsr	Base+001h	R	All	Status Register
dcr	Base+002h	R/W	All	Control Register
cFifo	Base+400h	R/W	010	Parallel Port Data FIFO
ecpDFifo	Base+400h	R/W	011	ECP FIFO (DATA)
tFifo	Base+400h	R/W	110	Test FIFO
cnfgA	Base+400h	R	111	Configuration Register A
cnfgB	Base+401h	R/W	111	Configuration Register B
ecr	Base+402h	R/W	All	Extended Control Register

Note: The base addresses are specified by CR23, which are determined by configuration register or hardware setting.

MODE	DESCRIPTION
000	SPP mode
001	PS/2 Parallel Port mode
010	Parallel Port Data FIFO mode
011	ECP Parallel Port mode
100	EPP mode (If this option is enabled in the CR9 and CR0 to select ECP/EPP mode)
101	Reserved
110	Test mode
111	Configuration mode

Note: The mode selection bits are bit 7-5 of the Extended Control Register.

### 6.3.2 Data and ecpAFifo Port

Modes 000 (SPP) and 001 (PS/2) (Data Port)

During a write operation, the Data Register latches the contents of the data bus on the rising edge of the input. The contents of this register are output to the PD0-PD7 ports. During a read operation, ports PD0-PD7 are read and output to the host. The bit definitions are as follows:

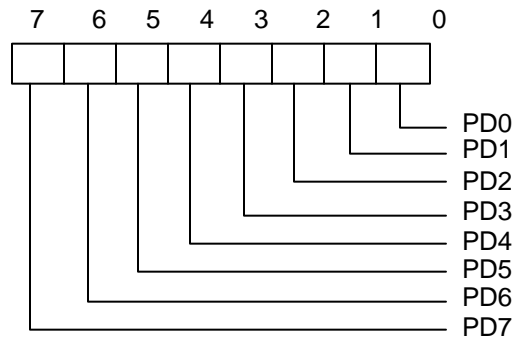

Mode 011 (ECP FIFO-Address/RLE)

A data byte written to this address is placed in the FIFO and tagged as an ECP Address/RLE. The hardware at the ECP port transmits this byte to the peripheral automatically. The operation of this register is defined only for the forward direction. The bit definitions are as follows:

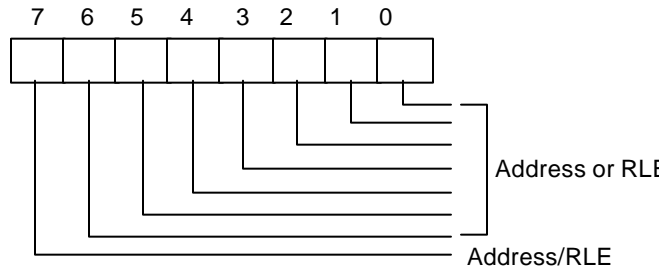

### 6.3.3 Device Status Register (DSR)

These bits are at low level during a read of the Printer Status Register. The bits of this status register are defined as follows:

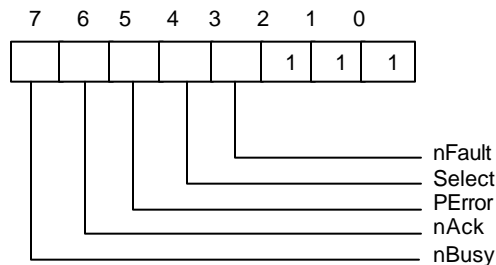

Bit 7: This bit reflects the complement of the Busy input.

Bit 6: This bit reflects the nAck input.

Bit 5: This bit reflects the PError input.

Bit 4: This bit reflects the Select input.

Bit 3: This bit reflects the nFault input.

Bit 2-0: These three bits are not implemented and are always logic one during a read.

### 6.3.4 Device Control Register (DCR)

The bit definitions are as follows:

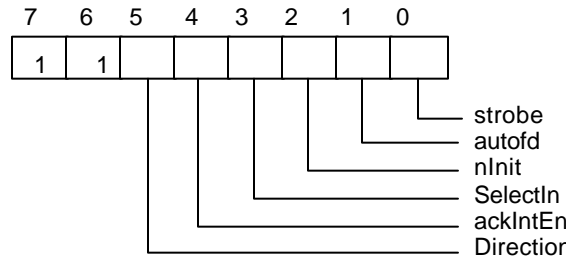

Bit 6, 7: These two bits are logic one during a read and cannot be written.

Bit 5: This bit has no effect and the direction is always out if mode = 000 or mode = 010. Direction is valid in all other modes.

- 0 the parallel port is in output mode.
- 1 the parallel port is in input mode.

Bit 4: Interrupt request enable. When this bit is set to a high level, it may be used to enable interrupt requests from the parallel port to the CPU due to a low to high transition on the ACK# input.

Bit 3: This bit is inverted and output to the SLIN# output.

- 0 The printer is not selected.
- 1 The printer is selected.

Bit 2: This bit is output to the INIT# output.

Bit 1: This bit is inverted and output to the AFD# output.

Bit 0: This bit is inverted and output to the STB# output.

**6.3.5 cFifo (Parallel Port Data FIFO) Mode = 010**

This mode is defined only for the forward direction. The standard parallel port protocol is used by a hardware handshake to the peripheral to transmit bytes written or DMAed from the system to this FIFO. Transfers to the FIFO are byte aligned.

**6.3.6 ecDFifo (ECP Data FIFO) Mode = 011**

When the direction bit is 0, bytes written or DMAed from the system to this FIFO are transmitted by a hardware handshake to the peripheral using the ECP parallel port protocol. Transfers to the FIFO are byte aligned.

When the direction bit is 1, data bytes from the peripheral are read under automatic hardware handshake from ECP into this FIFO. Reads or DMAs from the FIFO will return bytes of ECP data to the system.

**6.3.7 tFifo (Test FIFO Mode) Mode = 110**

Data bytes may be read, written, or DMAed to or from the system to this FIFO in any direction. Data in the tFIFO will not be transmitted to the parallel port lines. However, data in the tFIFO may be displayed on the parallel port data lines.

**6.3.8 cnfgA (Configuration Register A) Mode = 111**

This register is a read-only register. When it is read, 10H is returned. This indicates to the system that this is an 8-bit implementation.

**6.3.9 cnfgB (Configuration Register B) Mode = 111**

The bit definitions are as follows:

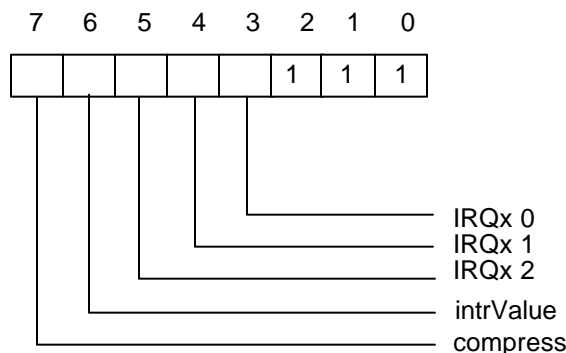

Bit 7: This bit is read-only. It is at low level during a read. This means that this chip does not support hardware RLE compression.

Bit 6: Returns the value on the ISA IRQ line to determine possible conflicts.





**PRELIMINARY**

Bit 5-3: Reflect the IRQ resource assigned for ECP port.

cnfgB[5:3]	IRQ resource
000	reflect other IRQ resources selected by PnP register (default)
001	IRQ7
010	IRQ9
011	IRQ10
100	IRQ11
101	IRQ14
110	IRQ15
111	IRQ5

Bit 2-0: These five bits are at high level during a read and can be written.

### 6.3.10 ecr (Extended Control Register) Mode = all

This register controls the extended ECP parallel port functions. The bit definitions are follows:

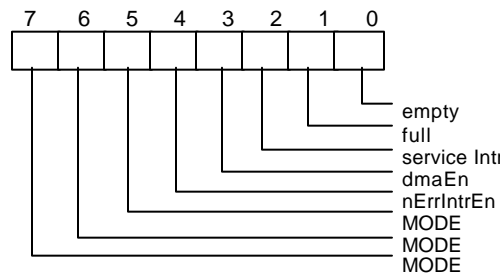

Bit 7-5: These bits are read/write and select the mode.

- 000 Standard Parallel Port mode. The FIFO is reset in this mode.
- 001 PS/2 Parallel Port mode. This is the same as 000 except that direction may be used to tri-state the data lines and reading the data register returns the value on the data lines and not the value in the data register.
- 010 Parallel Port FIFO mode. This is the same as 000 except that bytes are written or DMAed to the FIFO. FIFO data are automatically transmitted using the standard parallel port protocol. This mode is useful only when direction is 0.
- 011 ECP Parallel Port Mode. When the direction is 0 (forward direction), bytes placed into the ecpDFifo and bytes written to the ecpAFifo are placed in a single FIFO and auto transmitted to the peripheral using ECP Protocol. When the direction is 1 (reverse direction), bytes are moved from the ECP parallel port and packed into bytes in the ecpDFifo.
- 100 Selects EPP Mode. In this mode, EPP is activated if the EPP mode is selected.
- 101 Reserved.
- 110 Test Mode. The FIFO may be written and read in this mode, but the data will not be transmitted on the parallel port.
- 111 Configuration Mode. The cnfgA and cnfgB registers are accessible at 0x400 and 0x401 in this mode.



## PRELIMINARY

### Bit 4: Read/Write (Valid only in ECP Mode)

- 1 Disables the interrupt generated on the asserting edge of nFault.
- 0 Enables an interrupt pulse on the high to low edge of nFault. If nFault is asserted (interrupt) an interrupt will be generated and this bit is written from a 1 to 0.

### Bit 3: Read/Write

- 1 Enables DMA.
- 0 Disables DMA unconditionally.

### Bit 2: Read/Write

- 1 Disables DMA and all of the service interrupts.
- 0 Enables one of the following cases of interrupts. When one of the service interrupts has occurred, the serviceIntr bit is set to a 1 by hardware. This bit must be reset to 0 to re-enable the interrupts. Writing a 1 to this bit will not cause an interrupt.
  - (a) dmaEn = 1: During DMA this bit is set to a 1 when terminal count is reached.
  - (b) dmaEn = 0 direction = 0: This bit is set to 1 whenever there are writeIntr Threshold or more bytes free in the FIFO.
  - (c) dmaEn = 0 direction = 1: This bit is set to 1 whenever there are readIntr Threshold or more valid bytes to be read from the FIFO.

### Bit 1: Read only

- 0 The FIFO has at least 1 free byte.
- 1 The FIFO cannot accept another byte or the FIFO is completely full.

### Bit 0: Read only

- 0 The FIFO contains at least 1 byte of data.
- 1 The FIFO is completely empty.

### 6.3.11 Bit Map of ECP Port Registers

	D7	D6	D5	D4	D3	D2	D1	D0	NOTE
data	PD7	PD6	PD5	PD4	PD3	PD2	PD1	PD0	
ecpAFifo	Addr/RLE	Address or RLE field							2
dsr	nBusy	nAck	PError	Select	nFault	1	1	1	1
dcr	1	1	Directio	ackIntrEn	SelectIn	nIntr	autofd	strobe	1
cFifo	Parallel Port Data FIFO								2
ecpDFifo	ECP Data FIFO								2
tFifo	Test FIFO								2
cnfgA	0	0	0	1	0	0	0	0	
cnfgB	compress	intrValue	1	1	1	1	1	1	
ecr	MODE			nErrIntrEn	dmaEn	serviceIntr	full	empty	

#### Notes:

1. These registers are available in all modes.
2. All FIFOs use one common 16-byte FIFO.

## 6.3.12 ECP Pin Descriptions

NAME	TYPE	DESCRIPTION
nStrobe (HostClk)	O	The nStrobe registers data or address into the slave on the asserting edge during write operations. This signal handshakes with Busy.
PD<7:0>	I/O	These signals contains address or data or RLE data.
nAck (PeriphClk)	I	This signal indicates valid data driven by the peripheral when asserted. This signal handshakes with nAutoFd in reverse.
Busy (PeriphAck)	I	This signal deasserts to indicate that the peripheral can accept data. It indicates whether the data lines contain ECP command information or data in the reverse direction. When in reverse direction, normal data are transferred when Busy (PeriphAck) is high and an 8-bit command is transferred when it is low.
PError (nAckReverse)	I	This signal is used to acknowledge a change in the direction of the transfer (asserted = forward). The peripheral drives this signal low to acknowledge nReverseRequest. The host relies upon nAckReverse to determine when it is permitted to drive the data bus.
Select (Xflag)	I	Indicates printer on line.
nAutoFd (HostAck)	O	Requests a byte of data from the peripheral when it is asserted. This signal indicates whether the data lines contain ECP address or data in the forward direction. When in forward direction, normal data are transferred when nAutoFd (HostAck) is high and an 8-bit command is transferred when it is low.
nFault (nPeriphRequest)	I	Generates an error interrupt when it is asserted. This signal is valid only in the forward direction. The peripheral is permitted (but not required) to drive this pin low to request a reverse transfer during ECP Mode.
nInit (nReverseRequest)	O	This signal sets the transfer direction (asserted = reverse, deasserted = forward). This pin is driven low to place the channel in the reverse direction.
nSelectIn (ECPMode)	O	This signal is always deasserted in ECP mode.



### 6.3.13 ECP Operation

The host must negotiate on the parallel port to determine if the peripheral supports the ECP protocol before ECP operation. After negotiation, it is necessary to initialize some of the port bits. The following are required:

- (a) Set direction = 0, enabling the drivers.
- (b) Set strobe = 0, causing the nStrobe signal to default to the deasserted state.
- (c) Set autoFd = 0, causing the nAutoFd signal to default to the deasserted state.
- (d) Set mode = 011 (ECP Mode)

ECP address/RLE bytes or data bytes may be sent automatically by writing the ecpAFifo or ecpDFifo, respectively.

#### 6.3.13.1 Mode Switching

Software will execute P1284 negotiation and all operation prior to a data transfer phase under programmed I/O control (mode 000 or 001). Hardware provides an automatic control line handshake, moving data between the FIFO and the ECP port only in the data transfer phase (mode 011 or 010).

If the port is in mode 000 or 001 it may switch to any other mode. If the port is not in mode 000 or 001 it can only be switched into mode 000 or 001. The direction can be changed only in mode 001.

When in extended forward mode, the software should wait for the FIFO to be empty before switching back to mode 000 or 001. In ECP reverse mode the software waits for all the data to be read from the FIFO before changing back to mode 000 or 001.

#### 6.3.13.2 Command/Data

ECP mode allows the transfer of normal 8-bit data or 8-bit commands. In the forward direction, normal data are transferred when HostAck is high and an 8-bit command is transferred when HostAck is low. The most significant bits of the command indicate whether it is a run-length count (for compression) or a channel address.

In the reverse direction, normal data are transferred when PeriphAck is high and an 8bit command is transferred when PeriphAck is low. The most significant bit of the command is always zero.

#### 6.3.13.3 Data Compression

The W83627SF supports run length encoded (RLE) decompression in hardware and can transfer compressed data to a peripheral. Note that the odd (RLE) compression in hardware is not supported. In order to transfer data in ECP mode, the compression count is written to the ecpAFifo and the data byte is written to the ecpDFifo.

### 6.3.14 FIFO Operation

The FIFO threshold is set in configuration register 5. All data transfers to or from the parallel port can proceed in DMA or Programmed I/O (non-DMA) mode, as indicated by the selected mode. The FIFO is used by selecting the Parallel Port FIFO mode or ECP Parallel Port Mode. After a reset, the FIFO is disabled.

### **6.3.15 DMA Transfers**

DMA transfers are always to or from the ecpDFifo, tFifo, or CFifo. The DMA uses the standard PC DMA services. The ECP requests DMA transfers from the host by activating the PDRQ pin. The DMA will empty or fill the FIFO using the appropriate direction and mode. When the terminal count in the DMA controller is reached, an interrupt is generated and serviceIntr is asserted, which will disable the DMA.

### **6.3.16 Programmed I/O (NON-DMA) Mode**

The ECP or parallel port FIFOs can also be operated using interrupt driven programmed I/O. Programmed I/O transfers are to the ecpDFifo at 400H and ecpAFifo at 000H or from the ecpDFifo located at 400H, or to/from the tFifo at 400H. The host must set the direction, state, dmaEn = 0 and serviceIntr = 0 in the programmed I/O transfers.

The ECP requests programmed I/O transfers from the host by activating the IRQ pin. The programmed I/O will empty or fill the FIFO using the appropriate direction and mode.

## **6.4 Extension FDD Mode (EXTFDD)**

In this mode, the W83627SF changes the printer interface pins to FDC input/output pins, allowing the user to install a second floppy disk drive (FDD B) through the DB-25 printer connector. The pin assignments for the FDC input/output pins are shown in Table 6-1.

After the printer interface is set to EXTFDD mode, the following occur:

- (1) Pins MOB# and DSB# will be forced to inactive state.
- (2) Pins DSKCHG#, RDATA#, WP#, TRAK0#, INDEX# will be logically ORed with pins PD4-PD0 to serve as input signals to the FDC.
- (3) Pins PD4-PD0 each will have an internal resistor of about 1K ohm to serve as pull-up resistor for FDD open drain/collector output.
- (4) If the parallel port is set to EXTFDD mode after the system has booted DOS or another operating system, a warm reset is needed to enable the system to recognize the extension floppy drive.

## **6.5 Extension 2FDD Mode (EXT2FDD)**

In this mode, the W83627SF changes the printer interface pins to FDC input/output pins, allowing the user to install two external floppy disk drives through the DB-25 printer connector to replace internal floppy disk drives A and B. The pin assignments for the FDC input/output pins are shown in Table6-1.

After the printer interface is set to EXT2FDD mode, the following occur:

- (1) Pins MOA#, DSA#, MOB#, and DSB# will be forced to inactive state.
- (2) Pins DSKCHG#, RDATA#, WP#, TRAK0#, and INDEX# will be logically ORed with pins PD4-PD0 to serve as input signals to the FDC.
- (3) Pins PD4-PD0 each will have an internal resistor of about 1K ohm to serve as pull-up resistor for FDD open drain/collector output.
- (4) If the parallel port is set to EXT2FDD mode after the system has booted DOS or another operating system, a warm reset is needed to enable the system to recognize the extension floppy drive.

## 7. KEYBOARD CONTROLLER

The KBC (8042 with licensed KB BIOS) circuit of W83627SF is designed to provide the functions needed to interface a CPU with a keyboard and/or a PS/2 mouse, and can be used with IBM<sup>®</sup>-compatible personal computers or PS/2-based systems. The controller receives serial data from the keyboard or PS/2 mouse, checks the parity of the data, and presents the data to the system as a byte of data in its output buffer. Then, The controller will asserts an interrupt to the system when data are placed in its output buffer. The keyboard and PS/2 mouse are required to acknowledge all data transmissions. No transmission should be sent to the keyboard or PS/2 mouse until an acknowledge is received for the previous data byte.

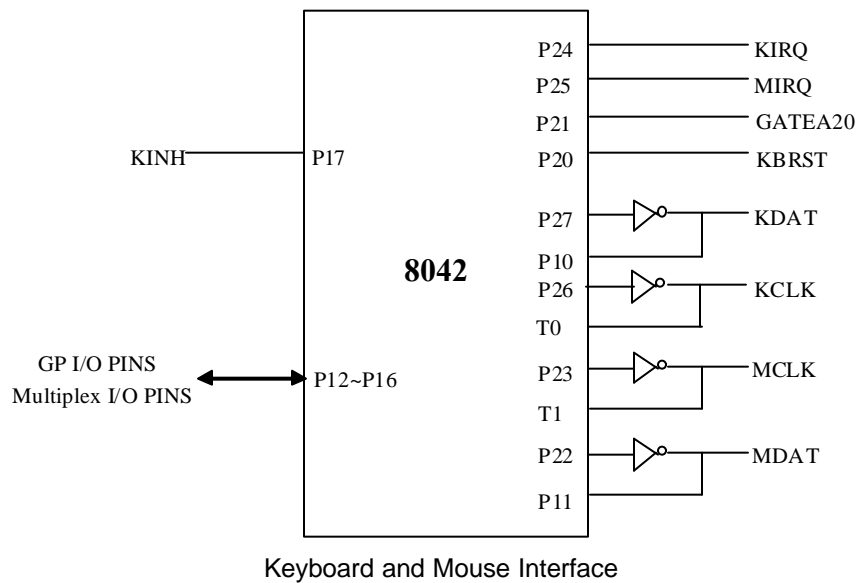

## 7.1 Output Buffer

The output buffer is an 8bit read-only register at I/O address 60H (Default, PnP programmable I/O address LD5-CR60 and LD5-CR61). The keyboard controller uses the output buffer to send the scan code received from the keyboard and data bytes required by commands to the system. The output buffer can only be read when the output buffer full bit in the register is "1".

## 7.2 Input Buffer

The input buffer is an 8-bit write-only register at I/O address 60H or 64H (Default, PnP programmable I/O address LD5-CR60, LD5-CR61, LD5-CR62, and LD5-CR63). Writing to address 60H sets a flag to indicate a data write; writing to address 64H sets a flag to indicate a command write. Data written to I/O address 60H is sent to keyboard (unless the keyboard controller is expecting a data byte) through the controller's input buffer only if the input buffer full bit in the status register is "0".

## 7.3 Status Register

The status register is an 8bit read-only register at I/O address 64H (Default, PnP programmable I/O address LD5-CR62 and LD5-CR63), that holds information about the status of the keyboard controller and interface. It may be read at any time.

BIT	BIT FUNCTION	DESCRIPTION
0	Output Buffer Full	0: Output buffer empty 1: Output buffer full
1	Input Buffer Full	0: Input buffer empty 1: Input buffer full
2	System Flag	This bit may be set to 0 or 1 by writing to the system flag bit in the command byte of the keyboard controller. It defaults to 0 after a power-on reset.
3	Command/Data	0: Data byte 1: Command byte
4	Inhibit Switch	0: Keyboard is inhibited 1: Keyboard is not inhibited
5	Auxiliary Device Output Buffer	0: Auxiliary device output buffer empty 1: Auxiliary device output buffer full
6	General Purpose Time-out	0: No time-out error 1: Time-out error
7	Parity Error	0: Odd parity 1: Even parity (error)





7.4 Commands

COMMAND	FUNCTION																		
20h	Read Command Byte of Keyboard Controller																		
60h	Write Command Byte of Keyboard Controller <table border="1" data-bbox="574 669 1161 1045"> <thead> <tr> <th>BIT</th> <th>BIT DEFINITION</th> </tr> </thead> <tbody> <tr> <td>7</td> <td>Reserved</td> </tr> <tr> <td>6</td> <td>IBM Keyboard Translate Mode</td> </tr> <tr> <td>5</td> <td>Disable Auxiliary Device</td> </tr> <tr> <td>4</td> <td>Disable Keyboard</td> </tr> <tr> <td>3</td> <td>Reserve</td> </tr> <tr> <td>2</td> <td>System Flag</td> </tr> <tr> <td>1</td> <td>Enable Auxiliary Interrupt</td> </tr> <tr> <td>0</td> <td>Enable Keyboard Interrupt</td> </tr> </tbody> </table>	BIT	BIT DEFINITION	7	Reserved	6	IBM Keyboard Translate Mode	5	Disable Auxiliary Device	4	Disable Keyboard	3	Reserve	2	System Flag	1	Enable Auxiliary Interrupt	0	Enable Keyboard Interrupt
BIT	BIT DEFINITION																		
7	Reserved																		
6	IBM Keyboard Translate Mode																		
5	Disable Auxiliary Device																		
4	Disable Keyboard																		
3	Reserve																		
2	System Flag																		
1	Enable Auxiliary Interrupt																		
0	Enable Keyboard Interrupt																		
A4h	Test Password Returns 0Fah if Password is loaded Returns 0F1h if Password is not loaded																		
A5h	Load Password Load Password until a "0" is received from the system																		
A6h	Enable Password Enable the checking of keystrokes for a match with the password																		
A7h	Disable Auxiliary Device Interface																		
A8h	Enable Auxiliary Device Interface																		
A9h	Interface Test <table border="1" data-bbox="574 1520 1216 1755"> <thead> <tr> <th>BIT</th> <th>BIT DEFINITION</th> </tr> </thead> <tbody> <tr> <td>00</td> <td>No Error Detected</td> </tr> <tr> <td>01</td> <td>Auxiliary Device "Clock" line is stuck low</td> </tr> <tr> <td>02</td> <td>Auxiliary Device "Clock" line is stuck high</td> </tr> <tr> <td>03</td> <td>Auxiliary Device "Data" line is stuck low</td> </tr> <tr> <td>04</td> <td>Auxiliary Device "Data" line is stuck low</td> </tr> </tbody> </table>	BIT	BIT DEFINITION	00	No Error Detected	01	Auxiliary Device "Clock" line is stuck low	02	Auxiliary Device "Clock" line is stuck high	03	Auxiliary Device "Data" line is stuck low	04	Auxiliary Device "Data" line is stuck low						
BIT	BIT DEFINITION																		
00	No Error Detected																		
01	Auxiliary Device "Clock" line is stuck low																		
02	Auxiliary Device "Clock" line is stuck high																		
03	Auxiliary Device "Data" line is stuck low																		
04	Auxiliary Device "Data" line is stuck low																		



PRELIMINARY

7.4 Commands, continued

COMMAND	FUNCTION												
AAh	Self-test Returns 055h if self test succeeds												
ABh	Interface Test <table border="1" data-bbox="565 690 1247 930"> <thead> <tr> <th>BIT</th> <th>BIT DEFINITION</th> </tr> </thead> <tbody> <tr> <td>00</td> <td>No Error Detected</td> </tr> <tr> <td>01</td> <td>Keyboard "Clock" line is stuck low</td> </tr> <tr> <td>02</td> <td>Keyboard "Clock" line is stuck high</td> </tr> <tr> <td>03</td> <td>Keyboard "Data" line is stuck low</td> </tr> <tr> <td>04</td> <td>Keyboard "Data" line is stuck high</td> </tr> </tbody> </table>	BIT	BIT DEFINITION	00	No Error Detected	01	Keyboard "Clock" line is stuck low	02	Keyboard "Clock" line is stuck high	03	Keyboard "Data" line is stuck low	04	Keyboard "Data" line is stuck high
BIT	BIT DEFINITION												
00	No Error Detected												
01	Keyboard "Clock" line is stuck low												
02	Keyboard "Clock" line is stuck high												
03	Keyboard "Data" line is stuck low												
04	Keyboard "Data" line is stuck high												
ADh	Disable Keyboard Interface												
AEh	Enable Keyboard Interface												
C0h	Read Input Port(P1) and send data to the system												
C1h	Continuously puts the lower four bits of Port1 into STATUS register												
C2h	Continuously puts the upper four bits of Port1 into STATUS register												
D0h	Send Port2 value to the system												
D1h	Only set/reset GateA20 line based on the system data bit 1												
D2h	Send data back to the system as if it came from Keyboard												
D3h	Send data back to the system as if it came from Auxiliary Device												
D4h	Output next received byte of data from system to Auxiliary Device												
E0h	Reports the status of the test inputs												
FXh	Pulse only RC(the reset line) low for 6μS if Command byte is even												



## PRELIMINARY

## 7.5 HARDWARE GATEA20/KEYBOARD RESET CONTROL LOGIC

The KBC implements a hardware control logic to speed-up GATEA20 and KBRESET. This control logic is controlled by LD5-CRF0 as follows:

### 7.5.1 KB Control Register (Logic Device 5, CR-F0)

BIT	7	6	5	4	3	2	1	0
NAME	KCLKS1	KCLKS0	Reserved	Reserved	Reserved	P92EN	HGA20	HKBRST

#### KCLKS1, KCLKS0

This 2 bits are for the KBC clock rate selection.

- = 0 0           KBC clock input is 6 Mhz
- = 0 1           KBC clock input is 8 Mhz
- = 1 0           KBC clock input is 12 Mhz
- = 1 1           KBC clock input is 16 Mhz

#### P92EN (Port 92 Enable)

A "1" on this bit enables Port 92 to control GATEA20 and KBRESET.

A "0" on this bit disables Port 92 functions.

#### HGA20 (Hardware GATE A20)

A "1" on this bit selects hardware GATEA20 control logic to control GATE A20 signal.

A "0" on this bit disables hardware GATEA20 control logic function.

#### HKBRST (Hardware Keyboard Reset)

A "1" on this bit selects hardware KB RESET control logic to control KBRESET signal.

A "0" on this bit disable hardware KB RESET control logic function.

When the KBC receives a data follows a "D1" command, the hardware control logic sets or clears GATE A20 according to the received data bit 1. Similarly, the hardware control logic sets or clears KBRESET depending on the received data bit 0. When the KBC receives a "FE" command, the KBRESET is pulse low for 6 $\mu$ S(Min.) with 14 $\mu$ S(Min.) delay.

GATEA20 and KBRESET are controlled by either the software control or the hardware control logic and they are mutually exclusive. Then, GATEA20 and KBRESET are merged along with Port92 when P92EN bit is set.

### 7.5.2 Port 92 Control Register (Default Value = 0x24)

BIT	7	6	5	4	3	2	1	0
NAME	Res. (0)	Res. (0)	Res. (1)	Res. (0)	Res. (0)	Res. (1)	SGA20	PLKBRST

#### SGA20 (Special GATE A20 Control)

A "1" on this bit drives GATE A20 signal to high.

A "0" on this bit drives GATE A20 signal to low.

#### PLKBRST (Pull-Low KBRESET)

A "1" on this bit causes KBRESET to drive low for 6 $\mu$ S(Min.) with 14 $\mu$ S(Min.) delay. Before issuing another keyboard reset command, the bit must be cleared.

## 8. GENERAL PURPOSE I/O

W83627SF provides 42 input/output ports that can be individually configured to perform a simple basic I/O function or a pre-defined alternate function. These 42 GP I/O ports are divided into seven groups. GP1 is configured through control registers in logical device 7, GP2 in logical device 8, GP3 and GP4 in logical device 9, GP5, GP6, and GP7 in logical device C. Users can configure each individual port to be an input or output port by programming respective bit in I/O selection register (0 = output, 1 = input). Invert port value by setting inversion register (0 = non-inverse, 1 = inverse). Port value is read/written through data register. Table 8.1 and 8.2 gives more details on GPIO's assignment. In addition, GP3 and GP4 are designed to be functional even in power loss condition (VCC is off). Figure 8.1 shows the GP I/O port's structure. Right after Power-on reset, those ports default to perform basic input function except ports in GP3 and GP4 which maintain their previous settings until a battery loss condition.

Table 8.1

<b>SELECTION BIT</b> 0 = OUTPUT 1 = INPUT	<b>INVERSION BIT</b> 0 = NON INVERSE 1 = INVERSE	<b>BASIC I/O OPERATIONS</b>
0	0	Basic non-inverting output
0	1	Basic inverting output
1	0	Basic non-inverting input
1	1	Basic inverting input

Table 8.2

GP I/O PORT DATA REGISTER	REGISTER BIT ASSIGNMENT	GP I/O PORT
GP1	BIT 0	GP10
	BIT 1	GP11
	BIT 2	GP12
	BIT 3	GP13
	BIT 4	GP14
	BIT 5	GP15
	BIT 6	GP16
	BIT 7	GP17
GP2	BIT 0	GP20
	BIT 1	GP21
	BIT 2	GP22
	BIT 3	GP23
	BIT 4	GP24
	BIT 5	GP25
	BIT 6	GP26
	BIT 7	GP27
GP3	BIT 0	GP30
	BIT 1	GP31
	BIT 2	GP32
	BIT 3	GP33
	BIT 4	GP34
	BIT 5	GP35
GP4	BIT 0	GP40
	BIT 1	GP41
	BIT 2	GP42

Table 8.2, continued

GP I/O PORT DATA REGISTER	REGISTER BIT ASSIGNMENT	GP I/O PORT
<b>GP5</b>	BIT 0	GP50
	BIT 1	GP51
	BIT 2	GP52
	BIT 3	GP53
	BIT 4	GP54
	BIT 5	GP55
	BIT 6	GP56
	BIT 7	GP57
<b>GP6</b>	BIT 0	GP60
	BIT 1	GP61
	BIT 2	GP62
	BIT 3	GP63
<b>GP7</b>	BIT 0	GP70
	BIT 1	GP71
	BIT 2	GP72
	BIT 3	GP73
	BIT 4	GP74

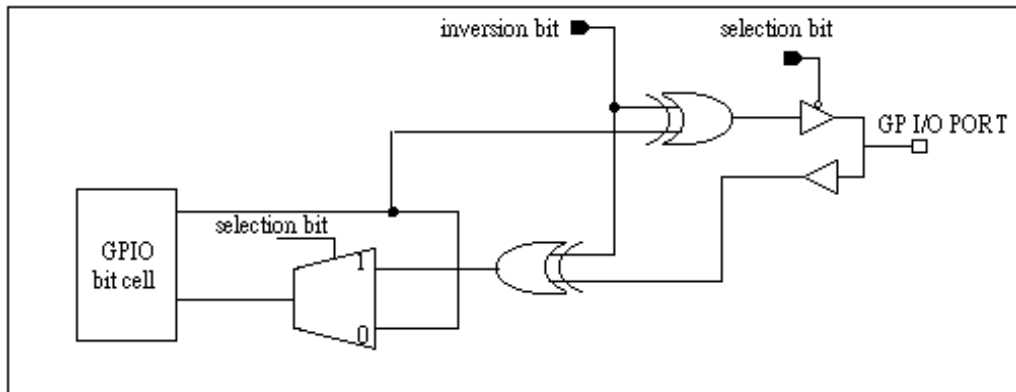
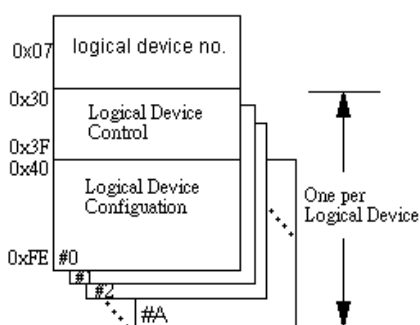

Figure 8.1

## 9. PLUG AND PLAY CONFIGURATION

The W83627SF uses Compatible PNP protocol to access configuration registers for setting up different types of configurations. In W83627SF, there are twelve Logical Devices (from Logical Device 0 to Logical Device C with the exception of logical device 4 for backward compatibility) which correspond to eleven individual functions: FDC (logical device 0), PRT (logical device 1), UART A (logical device 2), UART B (logical device 3), KBC (logical device 5), CIR (Consumer IR, logical device 6), GP1 (logical device 7), GP2 (logical device 8), GP3 and GP4 (logical device 9), ACPI ((logical device A), Smart Card interface (logical device B), and GP5, GP6, and GP7 (logical device C). Each Logical Device has its own configuration registers (above CR30). Host can access those registers by writing an appropriate logical device number into logical device select register at CR07.



### 9.1 Compatible PnP

#### 9.1.1 Extended Function Registers

In Compatible PnP, there are two ways to enter Extended Function and read or write the configuration registers. HEFRAS (CR26 bit 6) can be used to select one out of these two methods of entering the Extended Function mode as follows:

HEFRAS	address and value
0	write 87h to the location 2Eh twice
1	write 87h to the location 4Eh twice

After Power-on reset, the value on RTSA# (pin 43) is latched by HEFRAS of CR26. In Compatible PnP, a specific value (87h) must be written twice to the Extended Functions Enable Register (I/O port address 2Eh or 4Eh). Secondly, an index value (02h, 07h-FFh) must be written to the Extended Functions Index Register (I/O port address 2Eh or 4Eh same as Extended Functions Enable Register) to identify which



**PRELIMINARY**

configuration register is to be accessed. The designer can then access the desired configuration register through the Extended Functions Data Register (I/O port address 2Fh or 4Fh).

After programming of the configuration register is finished, an additional value (AAh) should be written to EFERs to exit the Extended Function mode to prevent unintentional access to those configuration registers. The designer can also set bit 5 of CR26 (LOCKREG) to high to protect the configuration registers against accidental accesses.

The configuration registers can be reset to their default or hardware settings only by a cold reset (pin MR = 1). A warm reset will not affect the configuration registers.

**9.1.2 Extended Functions Enable Registers (EFERs)**

After a power-on reset, the W83627SF enters the default operating mode. Before the W83627SF enters the extended function mode, a specific value must be programmed into the Extended Function Enable Register (EFER) so that the extended function register can be accessed. The Extended Function Enable Registers are write-only registers. On a PC/AT system, their port addresses are 2Eh or 4Eh (as described in previous section).

**9.1.3 Extended Function Index Registers (EFIRs), Extended Function Data Registers(EFDRs)**

After the extended function mode is entered, the Extended Function Index Register (EFIR) must be loaded with an index value (02h, 07h-FEh) to access Configuration Register 0 (CR0), Configuration Register 7 (CR07) to Configuration Register FE (CRFE), and so forth through the Extended Function Data Register (EFDR). The EFIRs are write-only registers with port address 2Eh or 4Eh (as described in section 12.2.1) on PC/AT systems; the EFDRs are read/write registers with port address 2Fh or 4Fh (as described in section 9.2.1) on PC/AT systems.

**9.2 Configuration Sequence**

To program W83627SF configuration registers, the following configuration sequence must be followed:

- (1). Enter the extended function mode
- (2). Configure the configuration registers
- (3). Exit the extended function mode

**9.2.1 Enter the extended function mode**

To place the chip into the extended function mode, two successive writes of 0x87 must be applied to Extended Function Enable Registers(EFERs, i.e. 2Eh or 4Eh).

### 9.2.2 Configure the configuration registers

The chip selects the logical device and activates the desired logical devices through Extended Function Index Register(EFIR) and Extended Function Data Register(EFDR). EFIR is located at the same address as EFER, and EFDR is located at address (EFIR+1).

First, write the Logical Device Number (i.e.,0x07) to the EFIR and then write the number of the desired logical device to the EFDR. If accessing the Chip(Global) Control Registers, this step is not required.

Secondly, write the address of the desired configuration register within the logical device to the EFIR and then write (or read) the desired configuration register through EFDR.

### 9.2.3 Exit the extended function mode

To exit the extended function mode, one write of 0xAA to EFER is required. Once the chip exits the extended function mode, it is in the normal running mode and is ready to enter the configuration mode.

### 9.2.4 Software programming example

The following example is written in Intel 8086 assembly language. It assumes that the EFER is located at 2Eh, so EFIR is located at 2Eh and EFDR is located at 2Fh. If HEFRAS (CR26 bit 6) is set, 4Eh can be directly replaced by 4Eh and 2Fh replaced by 4Fh.

```
-----  
; Enter the extended function mode ,interruptible double-write |  
-----  
MOV  DX,2EH  
MOV  AL,87H  
OUT  DX,AL  
OUT  DX,AL  
-----  
; Configure logical device 1, configuration register CRF0 |  
-----  
MOV  DX,2EH  
MOV  AL,07H  
OUT  DX,AL          ; point to Logical Device Number Reg.  
MOV  DX,2FH
```

## PRELIMINARY

```
MOV  AL,01H
OUT  DX,AL      ; select logical device 1
;
MOV  DX,2EH
MOV  AL,F0H
OUT  DX,AL      ; select CRF0
MOV  DX,2FH
MOV  AL,3CH
OUT  DX,AL      ; update CRF0 with value 3CH
;-----
; Exit extended function mode |
;-----
MOV  DX,2EH
MOV  AL,AAH
OUT  DX,AL
```

### 10. ACPI REGISTERS FEATURES

W83627SF supports both ACPI and legacy power managements. The switch logic of the power management block generates an SMI# interrupt in the legacy mode and an PME# interrupt in the ACPI mode. The new ACPI feature routes SMI#/PME# logic output either to SMI# or to PME#. The SMI#/PME# logic routes to SMI# only when both PME\_EN = 0 and SMIPME\_OE = 1. Similarly, the SMI#/PME# logic routes to PME# only when both PME\_EN = 1 and SMIPME\_OE = 1.

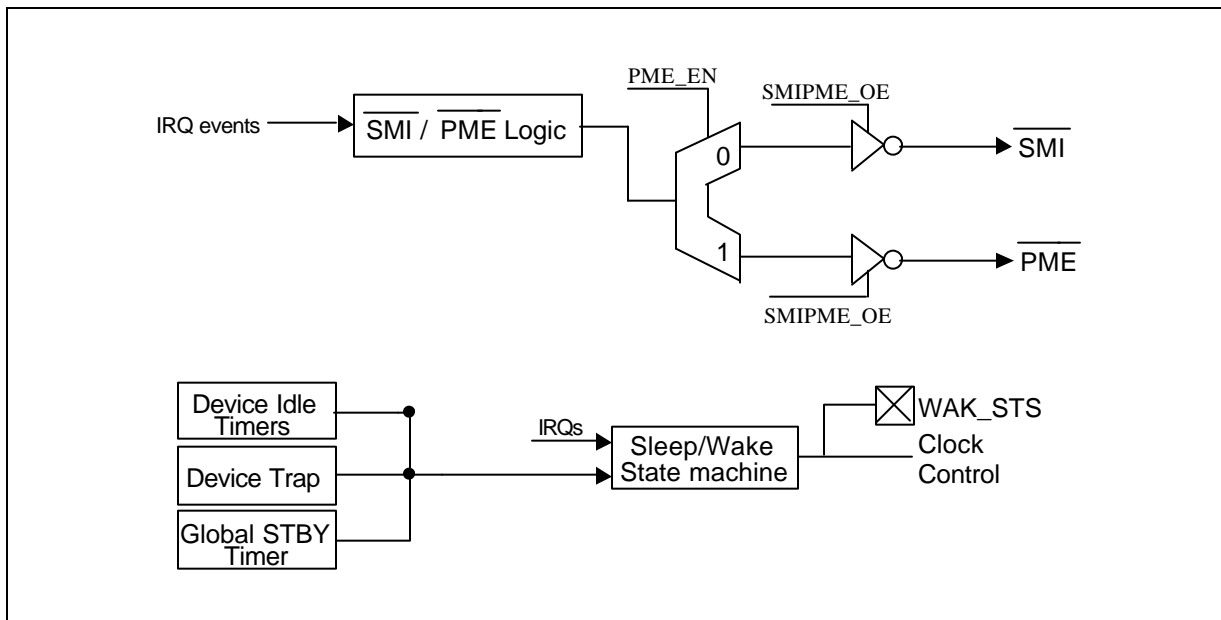



PRELIMINARY

## 11. SMART CARD INTERFACE

Because of similarity of transmission protocol to UART, the register map of Smart Card interface of Winbond I/O is designed to be UART-like for easy programming. Details of these registers are described as follows.

### 11.1 Receiver Buffer Register (RBR, read only at "base address + 0" when BDLAB = 0)

Data from IC card are buffered in this register for host to read.

### 11.2 Transmitter Buffer Register (TBR, write only at "base address + 0" when BDLAB = 0)

Host writes to this register to send data to IC card.

### 11.3 Interrupt Control Register (ICR, at "base address + 1" when BDLAB = 0)

This 8-bit register allows the four types of interrupts. The interrupt system can be completely disabled by resetting bits 0 through 4 of the Interrupt Control Register (ICR). A selected interrupt can be enabled by setting the appropriate bits of this register to a logical 1.

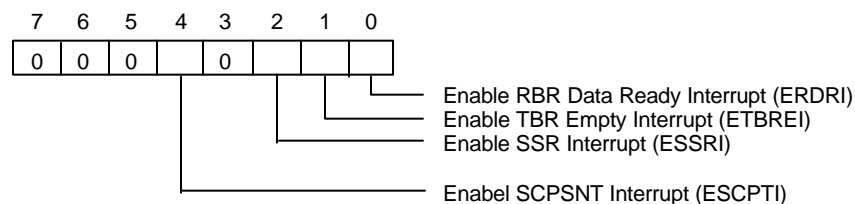

Bit 7-5: These bits are always logic 0.

Bit 4: ESCPTI. Setting this bit to a logical 1 enables SCPSNT interrupt when a card is inserted.

Bit 3: This bit is always logic 0.

Bit 2: ESSRI. Setting this bit to a logical 1 enables Smart Card interface status register interrupt.

Bit 1: ETBREI. Setting this bit to a logical 1 enables TBR empty interrupt.

Bit 0: ERDRI. Setting this bit to a logical 1 enables RBR data ready interrupt.

## 11.4 Interrupt Status Register (ISR, read only at "base address + 2")

This register reflects the Smart Card interface interrupt status, which is encoded by different interrupt sources into 4 bits.

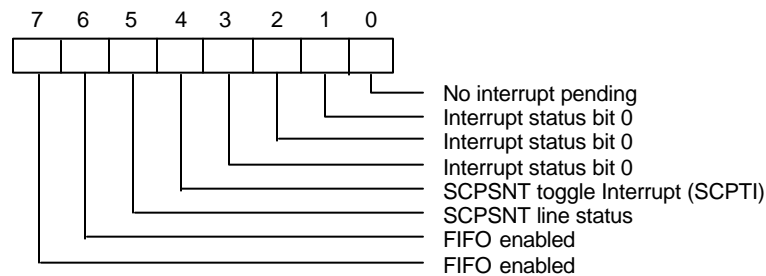

Bit 7, 6: These two bits are set to a logical 1 when SFR bit 0 = 1.

Bit 5: Reflect value of SCPSNT line status.

Bit 4: Set to 1 if SCPSNT toggles when this type of interrupt is enabled. Bit 0 of this register is also set to 0 if this type of interrupt occurs.

Bit 3 - 1: These three bits identify the priority level of the pending interrupt, as shown in the table below.

Bit 0: This bit is a logical 1 if there is no interrupt pending. If one of the interrupt sources has occurred, this bit will be set to a logical 0.

### INTERRUPT CONTROL FUNCTION

ISR				INTERRUPT SET AND FUNCTION			
Bit 3	Bit 2	Bit 1	Bit 0	Interrupt priority	Interrupt Type	Interrupt Source	Clear Interrupt
0	0	0	1	-	-	No Interrupt pending	-
0	1	1	0	First	Smart Card interface Receive Status	1. OER = 1 2. PBER =1 3. NSER = 1 4. SBD = 1	Read SCSR
0	1	0	0	Second	RBR Data Ready	1. RBR data ready 2. FIFO interrupt active level reached	1. Read RBR 2. Read RBR until FIFO data under active level
1	1	0	0	Second	FIFO Data Timeout	Data present in RX FIFO for 4 characters period of time since last access of RX FIFO.	Read RBR
0	0	1	0	Third	TBR Empty	TBR empty	1. Write data into TBR 2. Read ISR (if priority is third)

**11.5 Smart Card FIFO Control Register (SCFR, write only at "base address + 2")**

This register is used to control the FIFO functions of Smart Card interface.

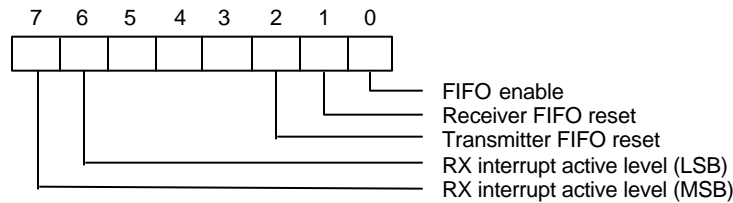

Bit 6, 7: These two bits are used to set the active level for the receiver FIFO interrupt. For example, if the interrupt active level is set as 4 bytes, once there are more than 4 data characters in the receiver FIFO, the interrupt will be activated to notify the CPU to read the data from the FIFO.

**FIFO TRIGGER LEVEL**

<b>BIT 7</b>	<b>BIT 6</b>	<b>RX FIFO INTERRUPT ACTIVE LEVEL (BYTES)</b>
0	0	01
0	1	04
1	0	08
1	1	14

Bit 5 - 3: Reserved.

Bit 2: Setting this bit to a logical 1 resets the TX FIFO counter logic to initial state. This bit will be cleared to a logical 0 by itself after being set to a logical 1.

Bit 1: Setting this bit to a logical 1 resets the RX FIFO counter logic to initial state. This bit will be cleared to a logical 0 by itself after being set to a logical 1.

Bit 0: This bit enables FIFO of Smart Card interface. This bit should be set to a logical 1 before other bits of SCFR are programmed.

### 11.6 Smart Card Control Register (SCCR, write only at "base address + 3")

The Smart Card Control Register controls and defines the parity bit protocol for asynchronous data communications.

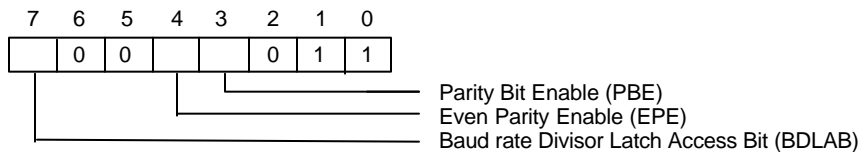

**Bit 7: BDLAB.** When this bit is set to a logical 1, designers can access the divisor (in 16-bit binary format) from the divisor latches of the baudrate generator during a read or write operation. When this bit is reset, the Receiver Buffer Register, the Transmitter Buffer Register, or the Interrupt Control Register can be accessed.

**Bit 6 - 5:** Reserved. Always 0 when read.

**Bit 4: EPE.** This bit describes the number of logic 1's in the data word bits and parity bit only when bit 3 is programmed. When this bit is set, an even number of logic 1's are sent or checked. When the bit is reset, an odd number of logic 1's are sent or checked.

**Bit 3: PBE.** When this bit is set, the position between the last data bit and the stop bit of the SOUT will be stuffed with the parity bit at the transmitter. For the receiver, the parity bit in the same position as the transmitter will be detected.

**Bit 2 – 0:** Reserved. Bit 2 is always 0 and bit 1 – 0 are always 1 when read.

### 11.7 Interrupt Enable Register (IER, at "base address + 4")

This register contains global interrupt enable bit of Smart Card interface.

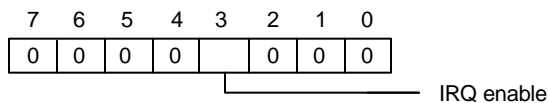

**Bit 7 - 4:** Reserved. Always 0 when read.

**Bit 3:** The Smart Card interface interrupt output is enabled by setting this bit to a logic 1.

**Bit 2 – 0:** Reserved. Always 0 when read.



## 11.8 Smart Card Status Register (SCSR, at "base address + 5")

This 8-bit register provides information about the status of the data transfer during communication.

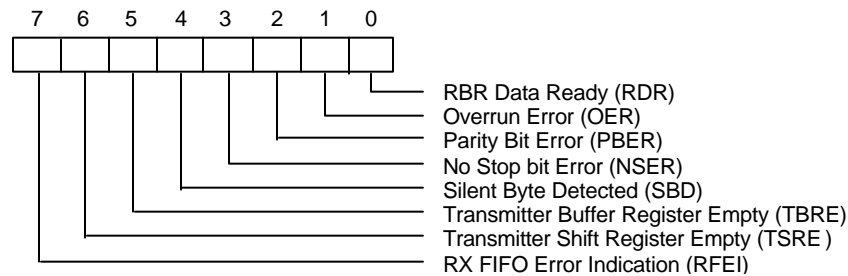

**Bit 7: RFEI.** This bit is set to a logic 1 when there is at least one parity bit error, no stop bit error or silent byte detected in the FIFO. It is cleared by reading SCSR until there are no remaining errors left in the FIFO.

**Bit 6: TSRE.** If the transmitting FIFO and TSR are both empty, it will be set to a logical 1. Otherwise, this bit will be reset to a logical 0.

**Bit 5: TBRE.** When a data character is transferred from TBR to TSR, this bit will be set to a logical 1. If ETBREI of ICR is a logical 1, an interrupt will be generated to notify the CPU to write the next data. It will be reset to a logical 0 when CPU writes data into TBR or FIFO.

**Bit 4: SBD.** This bit is set to a logical 1 to indicate that received data are kept in silent state for a full word time, including start bit, data bits, parity bit, and stop bits. When the CPU reads SCSR, it will clear this bit to a logical 0.

**Bit 3: NSER.** This bit is set to a logical 1 to indicate that the received data have no stop bit. When CPU reads SCSR, it will clear this bit to a logical 0.

**Bit 2: PBER.** This bit is set to a logical 1 to indicate that parity bit of received data is incorrect. When CPU reads SCSR, it will clear this bit to a logical 0.

**Bit 1: OER.** This bit is set to a logical 1 to indicate received data have been overwritten by the next received data before they were read by CPU. When CPU reads SCSR, it will clear this bit to a logical 0.

**Bit 0: RDR.** This bit is set to a logical 1 to indicate received data are ready to be read by CPU in the RBR or FIFO. After no data are left in the RBR or FIFO, the bit will be reset to a logical 0.

## 11.9 Extended Control Register (ECR, at "base address + 7")

This 8-bit register provides control settings for Smart Card interface.

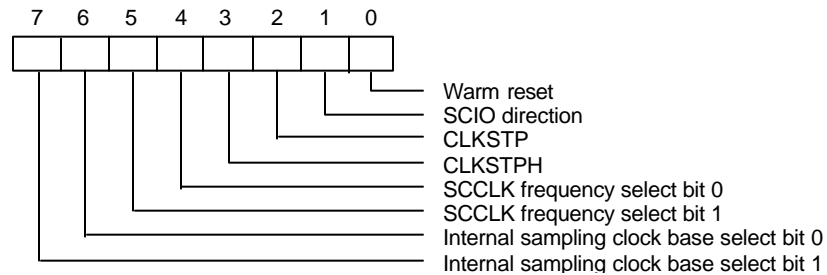

Bit 7 – 6: These two bits (BASESEL1 and BASESEL0 respectively) select internal sampling clock base multiplier versus baud rate.

BASESEL1, BASESEL0	multiplier
00	14x
01	16x
10	18x
11	16x

Bit 5 – 4: These two bits (CLKSEL1 and CLKSEL0 respectively) select frequency of SCCLK.

CLKSEL1, CLKSEL0	SCCLK frequency
00	1.5 MHz
01	3 MHz
10	6 MHz
11	12 MHz

Bit 3: CLKSTPH. This bit determines SCCLK stuck at high or low after CLKSTP is set to 1. SCCLK stays high if CLKSTPH is equal to 1 and stays low otherwise.

Bit 2: CLKSTP. Setting this bit to 1 will stop SCCLK.

Bit 1: SCDIR. This bit determine direction of SCIO pin. SCIO serves as an input port if SCDIR is 1. It is an output port if SCDIR is 0.

Bit 0: WRST. Writing a 1 to this bit issues a warm reset to IC card. It is self-cleared after writing a 1.



## PRELIMINARY

### **11.10 Baud rate divisor Latch High and Baud rate divisor Latch Low (BHL and BLL at "base address + 1" and "base address + 0" respectively when BDLAB = 1)**

Combining with BASESEL1 and BASESEL0 of ECR, these two bytes of registers provide user all the possible combinations to cover all the available settings regarding clock rate conversion factor and baud rate adjustment factor.



**PRELIMINARY**

Smart Card interface register bit map.

		Bit Number								
Register Address Base			0	1	2	3	4	5	6	7
+ 0 BDLAB = 0	Receiver Buffer Register (Read Only)	RBR	RX Data Bit 0	RX Data Bit 1	RX Data Bit 2	RX Data Bit 3	RX Data Bit 4	RX Data Bit 5	RX Data Bit 6	RX Data Bit 7
+ 0 BDLAB = 0	Transmitter Buffer Register (Write Only)	TBR	TX Data Bit 0	TX Data Bit 1	TX Data Bit 2	TX Data Bit 3	TX Data Bit 4	TX Data Bit 5	TX Data Bit 6	TX Data Bit 7
+ 1 BDLAB = 0	Interrupt Control Register	ICR	RBR Data Ready Interrupt Enable (ERDRI)	TBR Empty Interrupt Enable (ETBREI)	SSR INTERRUPT ENABLE (EUSRI)	0	SCPSNT toggle interrupt Enable (ESCPTI)	0	0	0
+ 2	Interrupt Status Register (Read Only)	ISR	"0" if Interrupt Pending	Interrupt Status Bit (0)	Interrupt Status Bit (1)	Interrupt Status Bit (2)	SCPSNT toggle interrupt status (SCPTI)	SCPSNT line status	FIFOs Enabled **	FIFOs Enabled **
+ 2	SMART CARD FIFO Control Register (Write Only)	SCFR	FIFO Enable	RCVR FIFO Reset	XMIT FIFO Reset	Reserved	Reserved	Reversed	RX Interrupt Active Level (LSB)	RX Interrupt Active Level (MSB)
+ 3	SMART CARD Control Register	SCCR	1	1	0	Parity Bit Enable (PBE)	Even Parity Enable (EPE)	0	0	Baudrate Divisor Latch Access Bit (BDLAB)
+ 4	Interrupt Enable Register	IER	0	0	0	IRQ Enable	0	0	0	0
+ 5	SMART CARD Status Register	SCSR	RBR Data Ready (RDR)	Overrun Error (OER)	Parity Bit Error (PBER)	No Stop Bit Error (NSER)	SILENT BYTE DETECTED (SBD)	TBR Empty (TBRE)	TSR Empty (TSRE)	RX FIFO Error Indication (RFEI)
+ 6	Reserved									
+ 7	Extended Control Register	ECR	Warm reset	SCIO direction	CLKSTP	CLKSTPH	SCCLK frequency select 0	SCCLK frequency select 1	Internal sampling clock base select 0	Internal sampling clock base select 1
+ 0 BDLAB = 1	Baudrate Divisor Latch Low	BLL	Bit 0	Bit 1	Bit 2	Bit 3	Bit 4	Bit 5	Bit 6	Bit 7
+ 1 BDLAB = 1	Baudrate Divisor Latch High	BHL	Bit 8	Bit 9	Bit 10	Bit 11	Bit 12	Bit 13	Bit 14	Bit 15

## 12. SERIAL IRQ

W83627SF supports a serial IRQ scheme. This allow a signal line to be used to report the legacy ISA interrupt requests. Because more than one device may need to share the signal serial IRQ signal line, an open drain signal scheme is used. The clock source is the PCI clock. The serial interrupt is transferred on the IRQSER signal, one cycle consisting of three frames types: a start frame, several IRQ/Data frame, and one Stop frame.

### 12.1 Start Frame

There are two modes of operation for the IRQSER Start frame: Quiet mode and Continuous mode.

In the Quiet mode, the peripheral drives the SERIRQ signal active low for one clock, and then tri-states it. This brings all the states machines of the peripherals from idle to active states. The host controller will then take over driving IRQSER signal low in the next clock and will continue driving the IRQSER low for programmable 3 to 7 clock periods. This makes the total number of clocks low for 4 to 8 clock periods. After these clocks, the host controller will drive the IRQSER high for one clock and then tri-states it.

In the Continuous mode, only the host controller initiates the START frame to update IRQ/Data line information. The host controller drives the IRQSER signal low for 4 to 8 clock periods. Upon a reset, the IRQSER signal is defaulted to the Continuous mode for the host controller to initiate the first Start frame.

### 12.2 IRQ/Data Frame

Once the start frame has been initiated, all the peripherals must start counting frames based on the rising edge of the start pulse. Each IRQ/Data Frame is three clocks long: Sample phase, Recovery phase, and Turn-around phase.

During the Sample phase, the peripheral drives SERIRQ low if the corresponding IRQ is active. If the corresponding IRQ is inactive, then IRQSER must be left tri-stated. During the Recovery phase, the peripheral device drives the IRQSER high. During the Turn-around phase, the peripheral device left the IRQSER tri-stated.

The IRQ/Data Frame has a number of specific order, as shown in Table 3-1.

Table 12-2 IRQSER Sampling periods

IRQ/Data Frame	Signal Sampled	# of clocks past Start
1	IRQ0	2
2	IRQ1	5
3	SMI#	8
4	IRQ3	11
5	IRQ4	14
6	IRQ5	17
7	IRQ6	20
8	IRQ7	23
9	IRQ8	26
10	IRQ9	29
11	IRQ10	32
12	IRQ11	35
13	IRQ12	38
14	IRQ13	41
15	IRQ14	44
16	IRQ15	47
17	IOCHCK#	50
18	INTA#	53
19	INTB#	56
20	INTC#	59
21	INTD#	62
32:22	Unassigned	95

### 12.3 Stop Frame

After all IRQ/Data Frames have completed, the host controller will terminate IRQSER by a Stop frame. Only the host controller can initiate the Stop frame by driving IRQSER low for 2 or 3 clocks. If the Stop Frame is low for 2 clocks, the next IRQSER cycle's Sample mode is the Quiet mode. If the Stop Frame is low for 3 clocks, the next IRQSER cycle's Sample mode is the Continuous mode.

## 13. CONFIGURATION REGISTER

### 13.1 Chip (Global) Control Register

#### CR02 (Default 0x00)

- Bit 7 - 1 : Reserved.
- Bit 0 : SWRST --> Soft Reset.

#### CR07

- Bit 7 - 0 : LDNB7 - LDNB0 --> Logical Device Number Bit 7 - 0

#### CR20

- Bit 7 - 0 : DEVIDB7 - DEBIDB0 --> Device ID Bit 7 - Bit 0 = 0x59 (read only).

#### CR21

- Bit 7 - 0 : DEVREVB7 - DEBREVB0 --> Device Rev Bit 7 - Bit 0 = 0x5v (read only, v is version number).

#### CR22 (Default 0xff)

- Bit 7 : Reserved.
- Bit 6 : HMPWD. Hardware monitor power down enable.
  - = 0 Power down
  - = 1 No Power down
- Bit 5 : URBPWD. UART B power down enable.
  - = 0 Power down
  - = 1 No Power down
- Bit 4 : URAPWD. UART A power down enable.
  - = 0 Power down
  - = 1 No Power down
- Bit 3 : PRTPWD. Printer port power down enable.
  - = 0 Power down
  - = 1 No Power down
- Bit 2 : Reserved.
- Bit 1 : SCPWD. Smart card interface power down enable.
  - = 0 Power down
  - = 1 No Power down
- Bit 0 : FDCPWD. FDC power down enable.
  - = 0 Power down
  - = 1 No Power down

### CR23 (Default 0x00)

Bit 7 - 1 : Reserved.

Bit 0 : IPD (Immediate Power Down). When set to 1, it will put the whole chip into power down mode immediately.

### CR24 (Default 0b1s000s0s)

Bit 7 : Reserved.

Bit 6 : CLKSEL

= 0 The clock input on Pin 1 should be 24 Mhz.

= 1 The clock input on Pin 1 should be 48 Mhz.

The corresponding power-on setting pin is SOUTB (pin 83).

Bit 5 - 3 : Reserved.

Bit 2 : ENKBC

= 0 KBC is disabled after hardware reset.

= 1 KBC is enabled after hardware reset.

This bit is read only, and set/reset by power-on setting pin. The corresponding power-on setting pin is SOUTA (pin 54).

Bit 1 : Reserved

Bit 0 : PNPCSV

= 0 The Compatible PnP address select registers have default values.

= 1 The Compatible PnP address select registers have no default value.

When trying to make a change to this bit, new value of PNPCSV must be complementary to the old one to make an effective change. For example, the user must set PNPCSV to 0 first and then reset it to 1 to reset these PnP registers if the present value of PNPCSV is 1. The corresponding power-on setting pin is NDTRA (pin 52).

### CR25 (Default 0x00)

This register contains enable bit for tri-state device's output pins when corresponding power down enable bit (specified in CR24) is set.

Bit 7 - 6 : Reserved

Bit 5 : URBTRI. For UART B device.

Bit 4 : URATRI. For UART A device.

Bit 3 : PRITRI. For printer port device.

Bit 2 : Reserved.

Bit 1 : SCTRI. For Smart Card interface.

Bit 0 : FDCTRI. For FDC device.



**CR26 (Default 0b0s000000)**

- Bit 7 : SEL4FDD  
= 0 Select two FDD mode.  
= 1 Select four FDD mode.
- Bit 6 : HEFRAS  
This bit defines how to enable Configuration mode. The corresponding power-on setting pin is NRTSA (pin 51).  
= 0 Write 87h to the location 2Eh twice.  
= 1 Write 87h to the location 4Eh twice.
- Bit 5 : LOCKREG  
= 0 Enable R/W Configuration Registers.  
= 1 Disable R/W Configuration Registers.
- Bit 4 : Reserve
- Bit 3 : DSFDLGRQ  
= 0 Enable FDC legacy mode on IRQ and DRQ selection, then DO register bit 3 is effective on selecting IRQ.  
= 1 Disable FDC legacy mode on IRQ and DRQ selection, then DO register bit 3 is not effective on selecting IRQ.
- Bit 2 : DSPRLGRQ  
= 0 Enable PRT legacy mode on IRQ and DRQ selection, then DCR bit 4 is effective on selecting IRQ.  
= 1 Disable PRT legacy mode on IRQ and DRQ selection, then DCR bit 4 is not effective on selecting IRQ.
- Bit 1 : DSUALGRQ  
= 0 Enable UART A legacy mode IRQ selecting, then MCR bit 3 is effective on selecting IRQ.  
= 1 Disable UART A legacy mode IRQ selecting, then MCR bit 3 is not effective on selecting IRQ.
- Bit 0 : DSUBLGRQ  
= 0 Enable UART B legacy mode IRQ selecting, then MCR bit 3 is effective on selecting IRQ.  
= 1 Disable UART B legacy mode IRQ selecting, then MCR bit 3 is not effective on selecting IRQ.

### CR28 (Default 0x00)

- Bit 7 - 3 : Reserved.
- Bit 2 - 0 : PRTMODS2 - PRTMODS0
  - = 0xx Parallel Port Mode
  - = 100 Reserved
  - = 101 External FDC Mode
  - = 110 Reserved
  - = 111 External two FDC Mode

### CR29 (GPIO3 multiplexed pin selection register. VBAT powered. Default 0x00)

- Bit 7 : PIN64S
  - = 0 SUSLED (SUSLED control bits are in CRF3 of Logical Device 9)
  - = 1 GP35
- Bit 6 : PIN69S
  - = 00 CIRRX#
  - = 01 GP34
- Bit 5 : PIN70S
  - = 0 RSMRST#
  - = 1 GP33
- Bit 4 : PIN71S
  - = 0 PWROK
  - = 1 GP32
- Bit 3 : PIN72S
  - = 0 PWRCTL#
  - = 1 GP31
- Bit 2 : PIN 73S
  - = 0 SLP\_SX#
  - = 1 GP30
- Bit 1 : Reserved.
- Bit 0 : PIN103S
  - = 0 Pin 103 and pin 104 function as GP41 and GP40 respectively.
  - = 1 Pin 103 is S5# signal input signal and pin 104 is system S3 state power control signal.

The corresponding power on setting pin is GP42 (pin 102). Its value is latched on the rising edge of internal RSMRST# signal (delay of rising edge of Internal RSMRST# signal from VSB on is half way of that of external RSMRST# pin).

The S3 state power control pin (pin 104) outputs low when VSB is on. It outputs high following the falling edge of SLP\_SX# (pin 73) signal falling edge. Then it is reset by the falling edge of S5# signal (pin 103).

\*Note: The falling edge of PWRCTL# signal (pin 72) is delayed an additional 5ms from the falling edge of SLP\_SX# signal for supporting STR (Suspend To RAM) function.

### CR2A (GPIO multiplexed pin selection register 1. VCC powered. Default 0X7C)

- Bit 7 : Port Select (select Game Port or General Purpose I/O Port 1)
  - = 0 Game Port
  - = 1 Enable bit 6 - 2 selection between GP10 ~ GP14 or 8042 KBC P12 - P16 for pin 128 - 124.
- Bit 6 : PIN128S
  - = 0 8042 P12
  - = 1 GP10
- Bit 5 : PIN127S
  - = 0 8042 P13
  - = 1 GP11
- Bit 4 : PIN126S
  - = 0 8042 P14
  - = 1 GP12
- Bit 3 : PIN125S
  - = 0 8042 P15
  - = 1 GP13
- Bit 2 : PIN124S
  - = 0 8042 P16
  - = 1 GP14
- Bit 1 : PIN120S
  - = 0 MSO (MIDI Serial data Output)
  - = 1 IRQIN0 (select IRQ resource through CRF3 bit 3 - 0 of Logical Device 8)
- Bit 0 : PIN119S
  - = 0 MSI (MIDI Serial data Input)
  - = 1 GP20

### CR2B (GPIO multiplexed pin selection register 2. VCC powered. Default 0xC0)

- Bit 7 - 6 : Reserved
- Bit 5 : PIN90S
  - = 0 PLED (PLED0 control bits are in CRF5 bit 7 - 6 of Logical Device 8)
  - = 1 GP23
- Bit 4 : PIN89S
  - = 0 WDTO (Watch Dog Timer is controlled by CRF5, CRF6, CRF7 of Logical Device 8)
  - = 1 GP24

- Bit 3 : PIN88S  
= 0 IRRX  
= 1 GP25
- Bit 2 : PIN87S  
= 0 IRTX  
= 1 GP26
- Bit 1 - 0 :PIN2S  
= 00 DRVDEN1  
= 01 SMI#  
= 10 IRQIN1 (select IRQ resource through CRF3 Bit 7 - 4 of Logical Device 8)  
= 11 GP27

### **CR2C (GPIO multiplexed pin selection register 3. VCC powered. Default 0bsss11111)**

- Bit 7 : Multi-function selection bit for pin 91, 92, 98 –100, and 106 – 110.  
= 0 GP21 – 22, GP60 – 62, and GP51 - GP55  
= 1 VID function  
The corresponding power on setting pin is GP57 (pin 102). Its value is latched on the rising edge of PWROK after VDD is on. Refer to CRF9and CRFA of Logical Device C for detailed description of VID function.
- Bit 6 - 5 : Multi-function selection bit for pin 112, 113, 115, 116, and 118  
= 00 GP74-71 and GP70  
= 01 Reserved  
= 10 Smart Card function  
= 11 Reserved  
The corresponding power on setting pin for bit 6 is GP70 (pin 118) and GP72 (pin 115) for bit5.  
Both values are latched on the rising edge of PWROK after VDD is on. If either bit 5or bit 6 is set to "1" after PWROK rising edge, these two bit can only be read. They can be written if powered on to select GP function initially and switch to Smard Card function.
- Bit 4-0 : Reserved

### **CR2D (Default 0x00)**

Test Mode: Reserved for Winbond.

### **CR2E (Default 0x00)**

Test Mode: Reserved for Winbond.

### **CR2F (Default 0x00)**

Test Mode: Reserved for Winbond.

### 13.2 Logical Device 0 (FDC)

#### CR30 (Default 0x01 if PNPCSV = 0 during POR, default 0x00 otherwise)

- Bit 7 - 1 : Reserved.
- Bit 0 = 1 Activates the logical device.
- = 0 Logical device is inactive.

#### CR60, CR 61 (Default 0x03, 0xf0 if PNPCSV = 0 during POR, default 0x00, 0x00 otherwise)

These two registers select FDC I/O base address [0x100:0xFF8] on 8 byte boundary.

#### CR70 (Default 0x06 if PNPCSV = 0 during POR, default 0x00 otherwise)

- Bit 7 - 4 : Reserved.
- Bit 3 - 0 : These bits select IRQ resource for FDC.

#### CR74 (Default 0x02 if PNPCSV = 0 during POR, default 0x04 otherwise)

- Bit 7 - 3 : Reserved.
- Bit 2 - 0 : These bits select DRQ resource for FDC.
  - = 0x00 DMA0
  - = 0x01 DMA1
  - = 0x02 DMA2
  - = 0x03 DMA3
  - = 0x04 - 0x07 No DMA active

#### CRF0 (Default 0x0E)

##### FDD Mode Register

- Bit 7 : FIPURDWN
  - This bit controls the internal pull-up resistors of the FDC input pins RDATA, INDEX, TRAK0, DSKCHG, and WP.
  - = 0 The internal pull-up resistors of FDC are turned on.(Default)
  - = 1 The internal pull-up resistors of FDC are turned off.
- Bit 6 : INTVERTZ
  - This bit determines the polarity of all FDD interface signals.
  - = 0 FDD interface signals are active low.
  - = 1 FDD interface signals are active high.

**PRELIMINARY**

- Bit 5 : DRV2EN (PS2 mode only)  
When this bit is a logic 0, indicates a second drive is installed and is reflected in status register A.
- Bit 4 : Swap Drive 0, 1 Mode  
= 0 No Swap (Default)  
= 1 Drive and Motor sel 0 and 1 are swapped.
- Bit 3 - 2 :Interface Mode  
= 11 AT Mode (Default)  
= 10 (Reserved)  
= 01 PS/2  
= 00 Model 30
- Bit 1 : FDC DMA Mode  
= 0 Burst Mode is enabled  
= 1 Non-Burst Mode (Default)
- Bit 0 : Floppy Mode  
= 0 Normal Floppy Mode (Default)  
= 1 Enhanced 3-mode FDD

**CRF1 (Default 0x00)**

- Bit 7 - 6 : Boot Floppy  
= 00 FDD A  
= 01 FDD B  
= 10 FDD C  
= 11 FDD D
- Bit 5, 4 : Media ID1, Media ID0. These bits will be reflected on FDC's Tape Drive Register bit 7, 6.
- Bit 3 - 2 : Density Select  
= 00 Normal (Default)  
= 01 Normal  
= 10 1 ( Forced to logic 1)  
= 11 0 ( Forced to logic 0)
- Bit 1 : DISFDDWR  
= 0 Enable FDD write.  
= 1 Disable FDD write(forces pins WE, WD stay high).
- Bit 0 : SWWP  
= 0 Normal, use WP to determine whether the FDD is write protected or not.  
= 1 FDD is always write-protected.

## **CRF2 (Default 0xFF)**

- Bit 7 - 6 : FDD D Drive Type
- Bit 5 - 4 : FDD C Drive Type
- Bit 3 - 2 : FDD B Drive Type
- Bit 1 - 0 : FDD A Drive Type

## **CRF4 (Default 0x00)**

FDD0 Selection:

- Bit 7 : Reserved.
- Bit 6 : Precomp. Disable.
  - = 1 Disable FDC Precompensation.
  - = 0 Enable FDC Precompensation.
- Bit 5 : Reserved.
- Bit 4 - 3 : DRTS1, DRTS0: Data Rate Table select (Refer to TABLE A).
  - = 00 Select Regular drives and 2.88 format
  - = 01 3-mode drive
  - = 10 2 Meg Tape
  - = 11 Reserved
- Bit 2 : Reserved.
- Bit 1:0 : DTYPE0, DTYPE1: Drive Type select (Refer to TABLE B).

## **CRF5 (Default 0x00)**

FDD1 Selection: Same as FDD0 of CRF4.



PRELIMINARY

TABLE A

Drive Rate Table Select		Data Rate		Selected Data Rate		SELDEN
DRTS1	DRTS0	DRATE1	DRATE0	MFM	FM	
0	0	1	1	1Meg	---	1
		0	0	500K	250K	1
		0	1	300K	150K	0
		1	0	250K	125K	0
0	1	1	1	1Meg	---	1
		0	0	500K	250K	1
		0	1	500K	250K	0
		1	0	250K	125K	0
1	0	1	1	1Meg	---	1
		0	0	500K	250K	1
		0	1	2Meg	---	0
		1	0	250K	125K	0

TABLE B

DTYPE0	DTYPE1	DRV DEN0(pin 2)	DRV DEN1(pin 3)	DRIVE TYPE
0	0	SELDEN	DRATE0	4/2/1 MB 3.5" " 2/1 MB 5.25" 2/1.6/1 MB 3.5" (3-MODE)
0	1	DRATE1	DRATE0	
1	0	$\overline{\text{SELDEN}}$	DRATE0	
1	1	DRATE0	DRATE1	



### 13.3 Logical Device 1 (Parallel Port)

#### CR30 (Default 0x01 if PNPCSV = 0 during POR, default 0x00 otherwise)

- Bit 7 - 1 : Reserved.
- Bit 0 = 1 Activates the logical device.
- = 0 Logical device is inactive.

#### CR60, CR 61 (Default 0x03, 0x78 if PNPCSV = 0 during POR, default 0x00, 0x00 otherwise)

These two registers select Parallel Port I/O base address.  
[0x100:0xFFC] on 4 byte boundary (EPP not supported) or  
[0x100:0xFF8] on 8 byte boundary (all modes supported, EPP is only available when the base address is on 8 byte boundary).

#### CR70 (Default 0x07 if PNPCSV = 0 during POR, default 0x00 otherwise)

- Bit 7 - 4 : Reserved.
- Bit [3:0] : These bits select IRQ resource for Parallel Port.

#### CR74 (Default 0x03)

- Bit 7 - 3 : Reserved.
- Bit 2 - 0 : These bits select DRQ resource for Parallel Port.
  - 0x00=DMA0
  - 0x01=DMA1
  - 0x02=DMA2
  - 0x03=DMA3
  - 0x04 - 0x07= No DMA active

#### CRF0 (Default 0x3F)

- Bit 7 : Reserved.
- Bit 6 - 3 : ECP FIFO Threshold.
- Bit 2 - 0 : Parallel Port Mode (CR28 PRTMODS2 = 0)
  - = 100 Printer Mode (Default)
  - = 000 Standard and Bi-direction (SPP) mode
  - = 001 EPP - 1.9 and SPP mode
  - = 101 EPP - 1.7 and SPP mode
  - = 010 ECP mode
  - = 011 ECP and EPP - 1.9 mode
  - = 111 ECP and EPP - 1.7 mode.

### 13.4 Logical Device 2 (UART A)

**CR30 (Default 0x01 if PNPCSV = 0 during POR, default 0x00 otherwise)**

- Bit 7 - 1 : Reserved.
- Bit 0 : = 1 Activates the logical device.  
= 0 Logical device is inactive.

**CR60, CR 61 (Default 0x03, 0xF8 if PNPCSV = 0 during POR, default 0x00, 0x00 otherwise)**

These two registers select Serial Port 1 I/O base address [0x100:0xFF8] on 8 byte boundary.

**CR70 (Default 0x04 if PNPCSV = 0 during POR, default 0x00 otherwise)**

- Bit 7 - 4 : Reserved.
- Bit 3 - 0 : These bits select IRQ resource for Serial Port 1.

**CRF0 (Default 0x00)**

- Bit 7 - 2 : Reserved.
- Bit 1 - 0 : SUACLKB1, SUACLKB0
  - = 00 UART A clock source is 1.8462 MHz (24MHz/13)
  - = 01 UART A clock source is 2 MHz (24MHz/12)
  - = 10 UART A clock source is 24 MHz (24MHz/1)
  - = 11 UART A clock source is 14.769 MHz (24MHz/1.625)

### 13.5 Logical Device 3 (UART B)

**CR30 (Default 0x01 if PNPCSV = 0 during POR, default 0x00 otherwise)**

- Bit 7 - 1 : Reserved.
- Bit 0 = 1 Activates the logical device.  
= 0 Logical device is inactive.

**CR60, CR 61 (Default 0x02, 0xF8 if PNPCSV = 0 during POR, default 0x00, 0x00 otherwise)**

These two registers select Serial Port 2 I/O base address [0x100:0xFF8] on 8 byte boundary.

**CR70 (Default 0x03 if PNPCSV = 0 during POR, default 0x00 otherwise)**

- Bit 7 - 4 : Reserved.
- Bit [3:0] : These bits select IRQ resource for Serial Port 2.

### CRF0 (Default 0x00)

- Bit 7 - 4 : Reserved.
- Bit 3 : RXW4C
  - = 0 No reception delay when SIR is changed from TX mode to RX mode.
  - = 1 Reception delays 4 characters-time (40 bit-time) when SIR is changed from TX mode to RX mode.
- Bit 2 : TXW4C
  - = 0 No transmission delay when SIR is changed from RX mode to TX mode.
  - = 1 Transmission delays 4 characters-time (40 bit-time) when SIR is changed from RX mode to TX mode.
- Bit 1 - 0 : SUBCLKB1, SUBCLKB0
  - = 00 UART B clock source is 1.8462 Mhz (24MHz/13)
  - = 01 UART B clock source is 2 Mhz (24MHz/12)
  - = 10 UART B clock source is 24 Mhz (24MHz/1)
  - = 11 UART B clock source is 14.769 Mhz (24mhz/1.625)

### CRF1 (Default 0x00)

- Bit 7 : Reserved.
- Bit 6 : IRLOCSEL. IR I/O pins' location select.
  - = 0 Through SINB/SOUTB.
  - = 1 Through IRRX/IRTX.
- Bit 5 : IRMODE2. IR function mode selection bit 2.
- Bit 4 : IRMODE1. IR function mode selection bit 1.
- Bit 3 : IRMODE0. IR function mode selection bit 0.

IR MODE	IR FUNCTION	IRTX	IRRX
00X	Disable	tri-state	high
010*	IrDA	Active pulse 1.6 $\mu$ S	Demodulation into SINB/IRRX
011*	IrDA	Active pulse 3/16 bit time	Demodulation into SINB/IRRX
100	ASK-IR	Inverting IRTX/SOUTB pin	routed to SINB/IRRX
101	ASK-IR	Inverting IRTX/SOUTB & 500 KHZ clock	routed to SINB/IRRX
110	ASK-IR	Inverting IRTX/SOUTB	Demodulation into SINB/IRRX
111*	ASK-IR	Inverting IRTX/SOUTB & 500 KHZ clock	Demodulation into SINB/IRRX

Note: The notation is normal mode in the IR function.

**PRELIMINARY**

- Bit 2 : HDUPLX. IR half/full duplex function select.  
= 0 The IR function is Full Duplex.  
= 1 The IR function is Half Duplex.
- Bit 1 : TX2INV.  
= 0 the SOUTB pin of UART B function or IRTX pin of IR function in normal condition.  
= 1 inverse the SOUTB pin of UART B function or IRTX pin of IR function.
- Bit 0 : RX2INV.  
= 0 the SINB pin of UART B function or IRRX pin of IR function in normal condition.  
= 1 inverse the SINB pin of UART B function or IRRX pin of IR function

**13.6 Logical Device 5 (KBC)**

**CR30 (Default 0x01 if PNPCSV = 0 during POR, default 0x00 otherwise)**

- Bit 7 - 1 : Reserved.  
Bit 0 = 1 Activates the logical device.  
= 0 Logical device is inactive.

**CR60, CR 61 (Default 0x00, 0x60 if PNPCSV = 0 during POR, default 0x00 otherwise)**

These two registers select the first KBC I/O base address [0x100:0xFFFF] on 1 byte boundary.

**CR62, CR 63 (Default 0x00, 0x64 if PNPCSV = 0 during POR, default 0x00 otherwise)**

These two registers select the second KBC I/O base address [0x100:0xFFFF] on 1 byte boundary.

**CR70 (Default 0x01 if PNPCSV = 0 during POR, default 0x00 otherwise)**

- Bit 7 - 4 : Reserved.  
Bit [3:0] These bits select IRQ resource for KINT (keyboard).

**CR72 (Default 0x0C if PNPCSV = 0 during POR, default 0x00 otherwise)**

- Bit 7 - 4 : Reserved.  
Bit [3:0] These bits select IRQ resource for MINT (PS2 Mouse)

## **CRF0 (Default 0x80)**

Bit 7 - 6 : KBC clock rate selection

= 00 Select 6MHz as KBC clock input.

= 01 Select 8MHz as KBC clock input.

= 10 Select 12Mhz as KBC clock input.

= 11 Select 16Mhz as KBC clock input.

(W83627SF/W83627HF/F-AW can support these 4 kinds of clock input, but W83627SF/W83627HF/F-PW only support 12MHz clock input)

Bit 5 - 3 : Reserved.

Bit 2 = 0 Port 92 disable.

= 1 Port 92 enable.

Bit 1 = 0 Gate20 software control.

= 1 Gate20 hardware speed up.

Bit 0 = 0 KBRST software control.

= 1 KBRST hardware speed up.

## **13.7 Logical Device 6 (CIR)**

### **CR30 (Default 0x00)**

Bit 7 - 1 : Reserved.

Bit 0 = 1 Activates the logical device.

= 0 Logical device is inactive.

### **CR60, CR 61 (Default 0x00, 0x00)**

These two registers select CIR I/O base address [0x100:0xFF8] on 8 byte boundary.

### **CR70 (Default 0x00)**

Bit 7 - 4 : Reserved.

Bit [3:0] These bits select IRQ resource for CIR.

### 13.8 Logical Device 7 (Game Port and MIDI Port and GPIO Port 1)

#### CR30 (Default 0x00)

Bit 7 - 3 : Reserved.

Bit 2 = 1 Activate MIDI Port.  
= 0 MIDI Port is disabled if bit 0 is also 0.

Bit 1 = 1 Activate Game Port.  
= 0 Game Port is disabled if bit 0 is also 0.

Bit 0 = 1 Activate both Game Port and MIDI Port.  
= 0 Game Port is disabled if bit 1 is also 0. MIDI Port is disabled if bit 2 is also 0.

#### CR60, CR 61 (Default 0x02, 0x01 if PNPCSV = 0 during POR, default 0x00 otherwise)

These two registers select the Game Port base address [0x100:0xFFFF] on 1 byte boundary.

#### CR62, CR 63 (Default 0x03, 0x30 if PNPCSV = 0 during POR, default 0x00 otherwise)

These two registers select the MIDI Port base address [0x100:0xFFFF] on 2 byte boundary.

#### CR70 (Default 0x09 if PNPCSV = 0 during POR, default 0x00 otherwise)

Bit 7 - 4 : Reserved.

Bit [3:0] : These bits select IRQ resource for MIDI Port .

#### CRF0 (GP10-GP17 I/O selection register. Default 0xFF)

When set to a '1', respective GPIO port is programmed as an input port.

When set to a '0', respective GPIO port is programmed as an output port.

#### CRF1 (GP10-GP17 data register. Default 0x00)

If a port is programmed to be an output port, then its respective bit can be read/written.

If a port is programmed to be an input port, then its respective bit can only be read.

#### CRF2 (GP10-GP17 inversion register. Default 0x00)

When set to a '1', the incoming/outgoing port value is inverted.

When set to a '0', the incoming/outgoing port value is the same as in data register.



## PRELIMINARY

**CRF3 (MIDI FIFO Threshold register. Default 0x00)**

Bit 7 - 6: MIDI FIFO Threshold.

BIT 7	BIT 6	RX FIFO INTERRUPT ACTIVE LEVEL (BYTES)
0	0	01
0	1	04
1	0	08
1	1	14

Bit 5-0: Reserved

**13.9 Logical Device 8 (GPIO Port 2)****CR30 (GP20-GP27 Default 0x00)**

Bit 7 - 1 : Reserved.

Bit 0 = 1 Activate GPIO2.

= 0 GPIO2 is inactive.

note: bit 0 is initialized to power on setting value of pin 81 on the rising edge of PWROK.

**CR60, CR 61 (Default 0x00, 0x00)**

These two registers select GP2 I/O base address [0x100:0xFF8] on 1 byte boundary.

**CRF0 (GP20-GP27 I/O selection register. Default 0xFF)**

When set to a '1', respective GPIO port is programmed as an input port.

When set to a '0', respective GPIO port is programmed as an output port.

**CRF1 (GP20-GP27 data register. Default 0x00)**

If a port is programmed to be an output port, then its respective bit can be read/written.

If a port is programmed to be an input port, then its respective bit can only be read.

**CRF2 (GP20-GP27 inversion register. Default 0x00)**

When set to a '1', the incoming/outgoing port value is inverted.

When set to a '0', the incoming/outgoing port value is the same as in data register.

**CRF3 (Default 0x00)**

Bit 7 - 4 : These bits select IRQ resource for IRQIN1.

Bit 3 - 0 : These bits select IRQ resource for IRQIN0.

**CRF4 (Reserved)**

### CRF5 (PLED mode register. Default 0x00)

- Bit 7-6 : select PLED mode
  - = 00 Power LED pin is tri-stated.
  - = 01 Power LED pin is driven low.
  - = 10 Power LED pin is a 1Hz toggle pulse with 50 duty cycle.
  - = 11 Power LED pin is a 1/4Hz toggle pulse with 50 duty cycle.
- Bit 5-4 : Reserved
- Bit 3 : select WDTO count mode.
  - = 0 second
  - = 1 minute
- Bit 2 : Enable the rising edge of keyboard Reset(P20) to force Time-out event.
  - = 0 Disable
  - = 1 Enable
- Bit 1 : Enable the keyboard Reset output Low pluse when Time-out.
  - = 0 Disable
  - = 1 Enable
- Bit 0 : Reserved

### CRF6 (Default 0x00 if ENGMTO is 0, 0x0A if ENGMTO is 1)

Watch Dog Timer Time-out value. Writing a non-zero value to this register causes the counter to load the value to Watch Dog Counter and start counting down. If the Bit 7 and Bit 6 are set, any Mouse Interrupt or Keyboard Interrupt event will also cause the reload of previously-loaded non-zero value to Watch Dog Counter and start counting down. Reading this register returns current value in Watch Dog Counter instead of Watch Dog Timer Time-out value.

- Bit 7 - 0 = 0x00 Time-out Disable
- = 0x01 Time-out occurs after 1 second/minute
- = 0x02 Time-out occurs after 2 second/minutes
- = 0x03 Time-out occurs after 3 second/minutes
- .....
- = 0xFF Time-out occurs after 255 second/minutes

note: The corresponding power on setting pin is pin 81 and its value is latched on the rising edge of PWROK.

- 1: CRF6 is initialized to be 0x0A and CR30 of this logical device is initialized to be 0x01.
- 0: CRF6 is initialized to be 0x00 and CR30 of this logical device is initialized to be 0x00.



**CRF7 (Default 0x00)**

- Bit 7 : Mouse interrupt reset Enable or Disable
  - = 1 Watch Dog Timer is reset upon a Mouse interrupt
  - = 0 Watch Dog Timer is not affected by Mouse interrupt
- Bit 6 : Keyboard interrupt reset Enable or Disable
  - = 1 Watch Dog Timer is reset upon a Keyboard interrupt
  - = 0 Watch Dog Timer is not affected by Keyboard interrupt
- Bit 5 : Force Watch Dog Timer Time-out, Write only\*
  - = 1 Force Watch Dog Timer time-out event; this bit is self-clearing.
- Bit 4 : Watch Dog Timer Status, R/W
  - = 1 Watch Dog Timer time-out occurred.
  - = 0 Watch Dog Timer counting
- Bit 3 -0 : These bits select IRQ resource for Watch Dog. Setting of 2 selects SMI.

**13.10 Logical Device 9 (GPIO Port 3,4 are powered by standby source VSB)**

**CR30 (Default 0x02)**

- Bit 7 - 1 : Reserved.
- Bit 1 = 1 Activate GP4.
  - = 0 GP4 is inactive.
- Bit 0 = 1 Activate GPIO3.
  - = 0 GPIO3 is inactive.

**CR60, CR 61 (Default 0x02, 0x90 if PNPCSV = 0 during POR, default 0x00 otherwise)**

These two registers select the GP3, GP4 port base address [0x100:0xFFF] on 2 byte boundary. GP3 is accessible through "base address" and GP4 is accessible through "base address" +1.

**CRF0 (GP30-GP35 I/O selection register. Default 0xFF Bit 7 - 6: Reserved)**

When set to a '1', respective GPIO port is programmed as an input port.  
When set to a '0', respective GPIO port is programmed as an output port.

**CRF1 (GP30-GP35 data register. Default 0x00 Bit 7 - 6: Reserved)**

If a port is programmed to be an output port, then its respective bit can be read/written.  
If a port is programmed to be an input port, then its respective bit can only be read.

**CRF2 (GP30-GP35 inversion register. Default 0x00 Bit 7 - 6: Reserved)**

When set to a '1', the incoming/outgoing port value is inverted.  
When set to a '0', the incoming/outgoing port value is the same as in data register.

**CRF3 (SUSLED mode register. Default 0x00)**

Bit 7 - 6 : select Suspend LED mode

= 00 Suspend LED pin is driven low.

= 01 Suspend LED pin is tri-stated.

= 10 Suspend LED pin is a 1 Hz toggle pulse with 50 duty cycle.

= 11 Suspend LED pin is a ¼Hz toggle pulse with 50 duty cycle.

Bit 5 - 0 : Reserved.

**CRF4 (GP40-GP42 I/O selection register. Default 0x00 Bit 7 - 3: Reserved)**

When set to a '1', respective GPIO port is programmed as an input port.

When set to a '0', respective GPIO port is programmed as an output port.

**CRF5 (GP40-GP42 data register. Default 0x00 Bit 7 - 3: Reserved)**

If a port is programmed to be an output port, then its respective bit can be read/written.

If a port is programmed to be an input port, then its respective bit can only be read.

**CRF6 (GP40-GP42 inversion register. Default 0x00 Bit 7 - 3: Reserved)**

When set to a '1', the incoming/outgoing port value is inverted.

When set to a '0', the incoming/outgoing port value is the same as in data register.

### 13.11 Logical Device A (ACPI)

**CR30 (Default 0x00)**

Bit 7 - 1 : Reserved.

Bit 0 = 1 Activates the logical device.

= 0 Logical device is inactive.

**CR70 (Default 0x00)**

Bit 7 - 4 : Reserved.

Bit 3 - 0 : These bits select IRQ resources for  $\overline{\text{PME}}$ .

**PRELIMINARY****CRE0 (Default 0x00)**

- Bit 7 : DIS-PANSW\_IN. Disable panel switch input to turn system power supply on.
  - = 0 PANSW\_IN is wire-ANDed and connected to PANSW\_OUT.
  - = 1 PANSW\_IN is blocked and can not affect PANSW\_OUT.
- Bit 6 : ENKBWAKEUP. Enable keyboard to wake up system through PANSW\_OUT.
  - = 0 Disable Keyboard wake-up function.
  - = 1 Enable Keyboard wake-up function.
- Bit 5 : ENMSWAKEUP. Enable Mouse to wake-up system via PANSW\_OUT.
  - = 0 Disable Mouse wake-up function.
  - = 1 Enable Mouse wake-up function.
- Bit 4 : MSRKEY. Select Mouse Left/Right Button to wake-up system via PANSW\_OUT.
  - = 0 Select click on Mouse Left-button twice to wake the system up.
  - = 1 Select click on Mouse right-button twice to wake the system up.
- Bit 3 : ENCIRWAKEUP. Enable CIR to wake-up system via PANSW\_OUT.
  - = 0 Disable CIR wake-up function.
  - = 1 Enable CIR wake-up function.
- Bit 2 : KB/MS Swap. Enable Keyboard/Mouse port-swap.
  - = 0 Keyboard/Mouse ports are not swapped.
  - = 1 Keyboard/Mouse ports are swapped.
- Bit 1 : MSXKEY. Enable any character received from Mouse to wake-up the system.
  - = 0 Two clicks of Mouse left/right-button wakes up the system.
  - = 1 One click of Mouse left/right-button wakes up the system.
- Bit 0 : KBXKEY. Enable any character received from Keyboard to wake-up the system.
  - = 0 Only predetermined specific key combination can wake up the system.
  - = 1 Any character received from Keyboard can wake up the system.

**CRE1 (Default 0x00) Keyboard Wake-Up Index Register**

This register is used to indicate which Keyboard Wake-Up Shift register or Predetermined key Register is to be read/written via CRE2. The first set of wake up key combination is in the range of 0x00 - 0x0E, the second set 0x30 - 0x3E, and the third set 0x40 - 0x4E. Incoming key combination can be read through 0x10 - 0x1E. The range of CIR wake-up index register is in 0x20 - 0x2F.

**CRE2 Keyboard Wake-Up Data Register**

This register holds the value of wake-up key register indicated by CRE1. This register can be read/written.

**CRE3 (Read only. Keyboard/Mouse Wake-Up Status Register)**

- Bit 7 – 6 : Reserved.
- Bit 5 : VSBLOSS: This bit is set when VSB is off.
- Bit 4 : PWRLOSS\_STS: This bit is set when previous power state is off..
- Bit 3 : CIR\_STS. The Panel switch event is caused by CIR wake-up event. This bit is cleared by reading this register.
- Bit 2 : PANSW\_STS. The Panel switch event is caused by PANSW\_IN. This bit is cleared by reading this register.
- Bit 1 : Mouse\_STS. The Panel switch event is caused by Mouse wake-up event. This bit is cleared by reading this register.
- Bit 0 : Keyboard\_STS. The Panel switch event is caused by Keyboard wake-up event. This bit is cleared by reading this register.

**CRE4 (Default 0x00)**

- Bit 7 : Power loss control bit 2.
  - 0 = Disable ACPI resume.
  - 1 = Enable ACPI resume.
- Bit 6 - 5 : Power loss control bit <1:0>
  - 00 = System always turns off when come back from power loss state.
  - 01 = System always turns on when come back from power loss state.
  - 10 = System turns on/off when come back from power loss state depending on the state before power loss.
  - 11 = Reserved.
- Bit 4 : Suspend clock source select
  - 0 = Use internal clock source.
  - 1 = Use external suspend clock source(32.768KHz).
- Bit 3 : Keyboard wake-up type select for wake-up the system from S1/S2.
  - 0 = Password or Hot keys programmed in the registers.
  - 1 = Any key.
- Bit 2 : Enable all wake-up event set in CRE0 can wake-up the system from S1/S2 state. This bit is cleared when wake-up event occurs.
  - 0 = Disable.
  - 1 = Enable.
- Bit 1 - 0 : Reserved.

## PRELIMINARY

### CRE5 (Default 0x00)

- Bit 7 : ENS5RST: Enable S5# signal (pin 103) to reset SUSLED mode register (CRF3 of logical device 9).  
= 0 SUSLED mode register is reset only by RSMRST#.  
= 1 SUSLED mode register can be reset by RSMRST# or S5#.
- Bit 6 - 0 : Compared Code Length. When the compared codes are stored in the data register, these data length should be written to this register.

### CRE6 (Default 0x00)

- Bit 7 : ENMDATUP: Enable an MDAT low pulse to wake up system through PSOUT#.  
= 0 Disable.  
= 1 Enable.
- Bit 6 : EN\_SCUP: Enable SCPSNT# of Smart Card interface to wake up system through PSOUT#.  
= 0 Disable.  
= 1 Enable.
- Bit 5 - 0 : CIR Baud Rate Divisor. The clock base of CIR is 32k Hz, so that the baud rate is 32khz divided by (CIR Baud Rate Divisor + 1).

### CRE7 (Default 0x00)

- Bit 7 : ENKD3. Enable the third set of key combination to wake up system through PANSW\_OUT if keyboard wake up function is enabled.  
= 0 Disable the third set of key combination.  
= 1 Enable the third set of key combination.
- Bit 6 : ENKD2. Enable the second set of key combination to wake up system through PANSW\_OUT if keyboard wake up function is enabled.  
= 0 Disable the second set of key combination.  
= 1 Enable the second set of key combination.
- Bit 5 : ENWIN98KEY. Enable WIN98 keyboard dedicated key to wake up system through PANSW\_OUT if keyboard wake up function is enabled.  
= 0 Disable WIN98 keyboard wake up.  
= 1 Enable WIN98 keyboard wake up.
- Bit 4 : EN\_ONPSOUT. Enable to issue a 0.5 s long PSOUT# pulse when system returns from power loss state and is supposed to be on as described in CRE4 bit 6, 5 of logical device A.  
= 0 Disable this function.  
= 1 Enable this function.

## PRELIMINARY

- Bit 3 : SELWDTORST: Select whether Watch Dog timer function is reset by LRESET\_L signal or PWROK signal.  
= 0 Watch Dog timer function is reset by LRESET\_L signal.  
= 1 Watch Dog timer function is reset by PWROK signal.
- Bit 2 : Reset CIR Power-On function. After using CIR power-on, the software should write logical 1 to restart CIR power-on function.
- Bit 1 : Invert RX Data.  
= 1 Inverting RX Data.  
= 0 Not inverting RX Data.
- Bit 0 : Enable Demodulation.  
= 1 Enable received signal to demodulate.  
= 0 Disable received signal to demodulate.

### CRF0 (Default 0x00)

- Bit 7 : CHIPPME. Chip level auto power management enable.  
= 0 disable the auto power management functions  
= 1 enable the auto power management functions.
- Bit 6 : CIRPME. Consumer IR port auto power management enable.  
= 0 disable the auto power management functions  
= 1 enable the auto power management functions.
- Bit 5 : MIDIPME. MIDI port auto power management enable.  
= 0 disable the auto power management functions  
= 1 enable the auto power management functions.
- Bit 4 : SCPME. Smart Card interface auto power management enable.  
= 0 disable the auto power management functions.  
= 1 enable the auto power management functions.
- Bit 3 : P RTPME. Printer port auto power management enable.  
= 0 disable the auto power management functions.  
= 1 enable the auto power management functions.
- Bit 2 : FDCPME. FDC auto power management enable.  
= 0 disable the auto power management functions.  
= 1 enable the auto power management functions.
- Bit 1 : URAPME. UART A auto power management enable.  
= 0 disable the auto power management functions.  
= 1 enable the auto power management functions.
- Bit 0 : URBPME. UART B auto power management enable.  
= 0 disable the auto power management functions.  
= 1 enable the auto power management functions.

## PRELIMINARY

### CRF1 (Default 0x00)

- Bit 7 : WAK\_STS. This bit is set when the chip is in the sleeping state and an enabled resume event occurs. Upon setting this bit, the sleeping/working state machine will transition the system to the working state. This bit is only set by hardware and is cleared by writing a 1 to this bit position or by the sleeping/working state machine automatically when the global standby timer expires.
- = 0 the chip is in the sleeping state.
  - = 1 the chip is in the working state.
- Bit 6 - 0 : Devices' trap status.

### CRF3 (Default 0x00)

- Bit 7 - 6 : Reserved. Return zero when read.
- Bit 5 - 0 : Device's IRQ status.
- These bits indicate the IRQ status of the individual device respectively. The device's IRQ status bit is set by their source device and is cleared by writing a 1. Writing a 0 has no effect.
- Bit 5 : MOUIRQSTS. MOUSE IRQ status.
  - Bit 4 : KBCIRQSTS. KBC IRQ status.
  - Bit 3 : PRTIRQSTS. printer port IRQ status.
  - Bit 2 : FDCIRQSTS. FDC IRQ status.
  - Bit 1 : URAIRQSTS. UART A IRQ status.
  - Bit 0 : URBIRQSTS. UART B IRQ status.

### CRF4 (Default 0x00)

- Bit 7 : Reserved. Return zero when read.
- Bit 4 - 0 : These bits indicate the IRQ status of the individual GPIO function or logical device respectively. The status bit is set by their source function or device and is cleared by writing a 1. Writing a 0 has no effect.
- Bit 6 : SCIRQSTS. Smart Card interface IRQ status.
  - Bit 5 : Reserved. Return zero when read.
  - Bit 4 : WDTIRQSTS. Watch dog timer IRQ status.
  - Bit 3 : CIRIRQSTS. Consumer IR IRQ status.
  - Bit 2 : MIDIIRQSTS. MIDI IRQ status.
  - Bit 1 : IRQIN1STS. IRQIN1 status.
  - Bit 0 : IRQIN0STS. IRQIN0 status.

**CRF6 (Default 0x00)**

Bit 7 - 6 : Reserved. Return zero when read.

Bit 5 - 0 : Enable bits of the  $\overline{\text{SMI}}/\overline{\text{PME}}$  generation due to the device's IRQ.

These bits enable the generation of an  $\overline{\text{SMI}}/\overline{\text{PME}}$  interrupt due to any IRQ of the devices.

$\overline{\text{SMI}}/\overline{\text{PME}}$  logic output = (MOUIRQEN and MOUIRQSTS) or (KBCIRQEN and KBCIRQSTS) or (PRTIRQEN and PRTIRQSTS) or (FDCIRQEN and FDCIRQSTS) or (URAIRQEN and URAIRQSTS) or (URBIRQEN and URBIRQSTS) or (SCIRQEN and SCIRQSTS) or (WDTIRQEN and WDTIRQSTS) or (IRQIN3EN and IRQIN3STS) or (IRQIN2EN and IRQIN2STS) or (IRQIN1EN and IRQIN1STS) or (IRQIN0EN and IRQIN0STS)

Bit 5 : MOUIRQEN.

= 0 disable the generation of an  $\overline{\text{SMI}}/\overline{\text{PME}}$  interrupt due to MOUSE's IRQ.

= 1 enable the generation of an  $\overline{\text{SMI}}/\overline{\text{PME}}$  interrupt due to MOUSE's IRQ.

Bit 4 : KBCIRQEN.

= 0 disable the generation of an  $\overline{\text{SMI}}/\overline{\text{PME}}$  interrupt due to KBC's IRQ.

= 1 enable the generation of an  $\overline{\text{SMI}}/\overline{\text{PME}}$  interrupt due to KBC's IRQ.

Bit 3 : PRTIRQEN.

= 0 disable the generation of an  $\overline{\text{SMI}}/\overline{\text{PME}}$  interrupt due to printer port's IRQ.

= 1 enable the generation of an  $\overline{\text{SMI}}/\overline{\text{PME}}$  interrupt due to printer port's IRQ.

Bit 2 : FDCIRQEN.

= 0 disable the generation of an  $\overline{\text{SMI}}/\overline{\text{PME}}$  interrupt due to FDC's IRQ.

= 1 enable the generation of an  $\overline{\text{SMI}}/\overline{\text{PME}}$  interrupt due to FDC's IRQ.

Bit 1 : URAIRQEN.

= 0 disable the generation of an  $\overline{\text{SMI}}/\overline{\text{PME}}$  interrupt due to UART A's IRQ.

= 1 enable the generation of an  $\overline{\text{SMI}}/\overline{\text{PME}}$  interrupt due to UART A's IRQ.

Bit 0 : URBIRQEN.

= 0 disable the generation of an  $\overline{\text{SMI}}/\overline{\text{PME}}$  interrupt due to UART B's IRQ.

= 1 enable the generation of an  $\overline{\text{SMI}}/\overline{\text{PME}}$  interrupt due to UART B's IRQ.



**CRF7 (Default 0x00)**

- Bit 7 : Reserved. Return zero when read.
- Bit 5 - 0 : Enable bits of the  $\overline{\text{SMI}}/\overline{\text{PME}}$  generation due to the GPIO IRQ function or device's IRQ.
- Bit 6 : SCIRQEN.  
= 0 disable the generation of an  $\overline{\text{SMI}}/\overline{\text{PME}}$  interrupt due to Smart Card interface IRQ.  
= 1 enable the generation of an  $\overline{\text{SMI}}/\overline{\text{PME}}$  interrupt due to Smart Card interface IRQ.
- Bit 5 : Reserved. Return zero when read.
- Bit 4 : WDTIRQEN.  
= 0 disable the generation of an  $\overline{\text{SMI}}/\overline{\text{PME}}$  interrupt due to watch dog timer's IRQ.  
= 1 enable the generation of an  $\overline{\text{SMI}}/\overline{\text{PME}}$  interrupt due to watch dog timer's IRQ.
- Bit 3 : CIRIRQEN.  
= 0 disable the generation of an  $\overline{\text{SMI}}/\overline{\text{PME}}$  interrupt due to CIR's IRQ.  
= 1 enable the generation of an  $\overline{\text{SMI}}/\overline{\text{PME}}$  interrupt due to CIR's IRQ.
- Bit 2 : MIDIIRQEN.  
= 0 disable the generation of an  $\overline{\text{SMI}}/\overline{\text{PME}}$  interrupt due to MIDI's IRQ.  
= 1 enable the generation of an  $\overline{\text{SMI}}/\overline{\text{PME}}$  interrupt due to MIDI's IRQ.
- Bit 1 : IRQIN1EN.  
= 0 disable the generation of an  $\overline{\text{SMI}}/\overline{\text{PME}}$  interrupt due to IRQIN1's IRQ.  
= 1 enable the generation of an  $\overline{\text{SMI}}/\overline{\text{PME}}$  interrupt due to IRQIN1's IRQ.
- Bit 0 : IRQIN0EN.  
= 0 disable the generation of an  $\overline{\text{SMI}}/\overline{\text{PME}}$  interrupt due to IRQIN0's IRQ.  
= 1 enable the generation of an  $\overline{\text{SMI}}/\overline{\text{PME}}$  interrupt due to IRQIN0's IRQ.

**CRF9 (Default 0x00)**

- Bit 7 - 3: Reserved. Return zero when read.
- Bit 2 : PME\_EN: Select the power management events to be either an  $\overline{\text{PME}}$  or  $\overline{\text{SMI}}$  interrupt for the IRQ events. Note that: this bit is valid only when SMIPME\_OE = 1.  
= 0 the power management events will generate an  $\overline{\text{SMI}}$  event.  
= 1 the power management events will generate an  $\overline{\text{PME}}$  event.
- Bit 1 : FSLEEP: This bit selects the fast expiry time of individual devices.  
= 0 1 second.  
= 1 8 milli-seconds.
- Bit 0 : SMIPME\_OE: This is the  $\overline{\text{SMI}}$  and  $\overline{\text{PME}}$  output enable bit.  
= 0 neither  $\overline{\text{SMI}}$  nor  $\overline{\text{PME}}$  will be generated. Only the IRQ status bit is set.  
= 1 an  $\overline{\text{SMI}}$  or  $\overline{\text{PME}}$  event will be generated.

**CRFE, FF (Default 0x00)**

Reserved for Winbond test.

**13.12 Logical Device B (Smart Card interface)**

**CR30 (Default 0x00)**

Bit 7 - 1 : Reserved.

Bit 0 = 1 Activates the logical device.

= 0 Logical device is inactive.

**CR60, CR 61 (Default 0x00, 0x00)**

These two registers select Smart Card interface base address [0x100:0xFFFF] on 8-byte boundary.

**CR70 (Default 0x00)**

Bit 7 - 4 : Reserved.

Bit 3 - 0 : These bits select IRQ resource for Smart Card interface.

**13.13 Logical Device C (GPIO Port 5,6,7 This power of the Ports is Source VCC)**

**CR30 (Default 0x07)**

Bit 7 - 3 : Reserved.

Bit 2 = 1 Activate GP7.  
= 0 GP7 is inactive.

Bit 1 = 1 Activate GP6.  
= 0 GP6 is inactive.

Bit 0 = 1 Activate GP5  
= 0 GP5 is inactive.

**CR60, CR 61 (Default 0x00)**

These two registers select the GP5, GP6, GP7 port base address [0x100:0xFFFF] on 4 byte boundary. GP5 is accessible through "base address", GP6 "base address" +1, and GP7 "base address" +2.

**CRF0 (GP50-GP56 I/O selection register. Default 0x00 Bit 7: Reserved)**

When set to a '1', respective GPIO port is programmed as an input port.

When set to a '0', respective GPIO port is programmed as an output port.

PRELIMINARY

**CRF1 (GP50-GP56 data register. Default 0x00 Bit 7: Reserved)**

If a port is programmed to be an output port, then its respective bit can be read/written.

If a port is programmed to be an input port, then its respective bit can only be read.

**CRF2 (GP50-GP56 inversion register. Default 0x00 Bit 7: Reserved)**

When set to a '1', the incoming/outgoing port value is inverted.

When set to a '0', the incoming/outgoing port value is the same as in data register.

**CRF3 (GP60-GP63 I/O selection register. Default 0xFF Bit 7-4: Reserved)**

When set to a '1', respective GPIO port is programmed as an input port.

When set to a '0', respective GPIO port is programmed as an output port.

**CRF4 (GP60-GP63 data register. Default 0xFF Bit 7-4: Reserved)**

If a port is programmed to be an output port, then its respective bit can be read/written.

If a port is programmed to be an input port, then its respective bit can only be read.

**CRF5 (GP60-GP63 inversion register. Default 0x00 Bit 7-4: Reserved)**

When set to a '1', the incoming/outgoing port value is inverted.

When set to a '0', the incoming/outgoing port value is the same as in data register.

**CRF6 (GP70-GP74 I/O selection register. Default 0xFF Bit 7-5: Reserved)**

When set to a '1', respective GPIO port is programmed as an input port.

When set to a '0', respective GPIO port is programmed as an output port.

**CRF7 (GP70-GP74 data register. Default 0xFF Bit 7-5: Reserved)**

If a port is programmed to be an output port, then its respective bit can be read/written.

If a port is programmed to be an input port, then its respective bit can only be read.

**CRF8 (GP70-GP74 inversion register. Default 0x00 Bit 7-5: Reserved)**

When set to a '1', the incoming/outgoing port value is inverted.

When set to a '0', the incoming/outgoing port value is the same as in data register.

**CRF9 (VID input data register. Bit 7 - 5: Reserved)**

This register is read only. It contains original VID value.

Bit 7 – 5 : Reserved.

Bit 4 – 0 : Original VID value.

**CRFA (VID output data register)**

This register allows user to configure different VID value. It can be read or written.

- Bit 7 : Select VID code tables.  
= 0 old VID code table.  
= 1 new VID code table.

Bit 6 – 5 : VID guarding bits. The corresponding power on setting pins are GP56, 66 and their values are latched on the rising edge of PWROK signal.

Bit 6	Bit 5	Limit
0	0	No constraint
0	1	3 units constraint
1	0	4 units constraint
1	1	5 units constraint

Bit 4 – 0 : configurable VID output value.

If VIDSEL of CR2C is 1 (select VID function), GP22, 21, 62 - 60 function as VID inputs and 55 - 51 function as VID outputs. During PWROK = 0, GP55~51 (VIDOUT) are equivalent to GP22, 21, 62~60 (VIDIN). After power on, User may configure LC.CRFA.bit4 - 0 to output a new VIDOUT combination if this new combination comply with the constraints of VID guarding bits specified in bit 6, 5 of this register. VID outputs are equal to VID inputs if constraint is not met.

## 14. SPECIFICATIONS

### 14.1 Absolute Maximum Ratings

PARAMETER	RATING	UNIT
Power Supply Voltage (5V)	-0.5 to 7.0	V
Input Voltage	-0.5 to VDD+0.5	V
RTC Battery Voltage VBAT	2.2 to 4.0	V
Operating Temperature	0 to +70	°C
Storage Temperature	-55 to +150	°C

Note: Exposure to conditions beyond those listed under Absolute Maximum Ratings may adversely affect the life and reliability of the device.

### 14.2 DC CHARACTERISTICS

(Ta = 0° C to 70° C, VDD = 5V ± 10%, VSS = 0V)

PARAMETER	SYM.	MIN.	TYP.	MAX.	UNIT	CONDITIONS
RTC Battery Quiescent Current	IBAT			2.4	uA	VBAT = 2.5 V
ACPI Stand-by Power Supply Quiescent Current	IBAT			2.0	mA	VSB = 5.0 V, All ACPI pins are not connected.
<b>I/O<sub>8t</sub> - TTL level bi-directional pin with source-sink capability of 8 mA</b>						
Input Low Voltage	V <sub>IL</sub>			0.8	V	
Input High Voltage	V <sub>IH</sub>	2.0			V	
Output Low Voltage	V <sub>OL</sub>			0.4	V	I <sub>OL</sub> = 8 mA
Output High Voltage	V <sub>OH</sub>	2.4			V	I <sub>OH</sub> = - 8 mA
Input High Leakage	I <sub>LH</sub>			+10	μA	V <sub>IN</sub> = VDD
Input Low Leakage	I <sub>LIL</sub>			-10	μA	V <sub>IN</sub> = 0V
<b>I/O<sub>12t</sub> - TTL level bi-directional pin with source-sink capability of 12 mA</b>						
Input Low Voltage	V <sub>IL</sub>			0.8	V	
Input High Voltage	V <sub>IH</sub>	2.0			V	
Output Low Voltage	V <sub>OL</sub>			0.4	V	I <sub>OL</sub> = 12 mA
Output High Voltage	V <sub>OH</sub>	2.4			V	I <sub>OH</sub> = -12 mA
Input High Leakage	I <sub>LH</sub>			+10	μA	V <sub>IN</sub> = VDD
Input Low Leakage	I <sub>LIL</sub>			-10	μA	V <sub>IN</sub> = 0V

## 14.2 DC CHARACTERISTICS, continued

PARAMETER	SYM.	MIN.	TYP.	MAX.	UNIT	CONDITIONS
<b>I/O<sub>12tp3</sub> - 3.3 V TTL level bi-directional pin with source-sink capability of 12 mA</b>						
Input Low Voltage	V <sub>IL</sub>			0.8	V	
Input High Voltage	V <sub>IH</sub>	2.0			V	
Output Low Voltage	V <sub>OL</sub>			0.4	V	I <sub>OL</sub> = 12 mA
Output High Voltage	V <sub>OH</sub>	2.4			V	I <sub>OH</sub> = -12 mA
Input High Leakage	I <sub>LIH</sub>			+10	μA	V <sub>IN</sub> = 3.3V
Input Low Leakage	I <sub>LIL</sub>			-10	μA	V <sub>IN</sub> = 0V
<b>I/OD<sub>12t</sub> - TTL level bi-directional pin with sink capability of 12 mA and open-drain</b>						
Input Low Voltage	V <sub>IL</sub>			0.8	V	
Input High Voltage	V <sub>IH</sub>	2.0			V	
Output Low Voltage	V <sub>OL</sub>			0.4	V	I <sub>OL</sub> = 12 mA
Input High Leakage	I <sub>LIH</sub>			+10	μA	V <sub>IN</sub> = 3.3V
Input Low Leakage	I <sub>LIL</sub>			-10	μA	V <sub>IN</sub> = 0V
<b>I/O<sub>24t</sub> - TTL level bi-directional pin with source-sink capability of 24 mA</b>						
Input Low Voltage	V <sub>IL</sub>			0.8	V	
Input High Voltage	V <sub>IH</sub>	2.0			V	
Output Low Voltage	V <sub>OL</sub>			0.4	V	I <sub>OL</sub> = 24 mA
Output High Voltage	V <sub>OH</sub>	2.4			V	I <sub>OH</sub> = -24 mA
Input High Leakage	I <sub>LIH</sub>			+10	μA	V <sub>IN</sub> = V <sub>DD</sub>
Input Low Leakage	I <sub>LIL</sub>			-10	μA	V <sub>IN</sub> = 0V
<b>OUT<sub>12t</sub> - TTL level output pin with source-sink capability of 12 mA</b>						
Output Low Voltage	V <sub>OL</sub>			0.4	V	I <sub>OL</sub> = 12 mA
Output High Voltage	V <sub>OH</sub>	2.4			V	I <sub>OH</sub> = -12 mA
<b>OUT<sub>12tp3</sub> - 3.3 V TTL level output pin with source-sink capability of 12 mA</b>						
Output Low Voltage	V <sub>OL</sub>			0.4	V	I <sub>OL</sub> = 12 mA
Output High Voltage	V <sub>OH</sub>	2.4			V	I <sub>OH</sub> = -12 mA
<b>OD<sub>12</sub> - Open-drain output pin with sink capability of 12 mA</b>						
Output Low Voltage	V <sub>OL</sub>			0.4	V	I <sub>OL</sub> = 12 mA
<b>OD<sub>24</sub> - Open-drain output pin with sink capability of 24 mA</b>						
Output Low Voltage	V <sub>OL</sub>			0.4	V	I <sub>OL</sub> = 24 mA

14.2 DC CHARACTERISTICS, continued

PARAMETER	SYM.	MIN.	TYP.	MAX.	UNIT	CONDITIONS	
<b>IN<sub>td</sub> - TTL level input pin with internal pull down resistor</b>							
Input Low Voltage	V <sub>IL</sub>			0.8	V		
Input High Voltage	V <sub>IH</sub>	2.0			V		
Input High Leakage	I <sub>LH</sub>			+10	μA	V <sub>IN</sub> = V <sub>DD</sub>	
Input Low Leakage	I <sub>LL</sub>			-10	μA	V <sub>IN</sub> = 0 V	
pull down resistor	R			47	KΩ		
<b>IN<sub>t</sub> - TTL level input pin</b>							
Input Low Voltage	V <sub>IL</sub>			0.8	V		
Input High Voltage	V <sub>IH</sub>	2.0			V		
Input High Leakage	I <sub>LH</sub>			+10	μA	V <sub>IN</sub> = V <sub>DD</sub>	
Input Low Leakage	I <sub>LL</sub>			-10	μA	V <sub>IN</sub> = 0 V	
<b>IN<sub>CS</sub> - CMOS level Schmitt-triggered input pin</b>							
Input Low Threshold Voltage	V <sub>t-</sub>	1.3	1.5	1.7	V	V <sub>DD</sub> = 5 V	
Input High Threshold Voltage	V <sub>t+</sub>	3.2	3.5	3.8	V	V <sub>DD</sub> = 5 V	
Hysteresis	V <sub>TH</sub>	1.5	2		V	V <sub>DD</sub> = 5 V	
Input High Leakage	I <sub>LH</sub>			+10	μA	V <sub>IN</sub> = V <sub>DD</sub>	
Input Low Leakage	I <sub>LL</sub>			-10	μA	V <sub>IN</sub> = 0 V	
<b>IN<sub>ts</sub> - TTL level Schmitt-triggered input pin</b>							
Input Low Threshold Voltage	V <sub>t-</sub>	0.5	0.8	1.1	V	V <sub>DD</sub> = 5 V	
Input High Threshold Voltage	V <sub>t+</sub>	1.6	2.0	2.4	V	V <sub>DD</sub> = 5 V	
Hysteresis	V <sub>TH</sub>	0.5	1.2		V	V <sub>DD</sub> = 5 V	
Input High Leakage	I <sub>LH</sub>			+10	μA	V <sub>IN</sub> = V <sub>DD</sub>	
Input Low Leakage	I <sub>LL</sub>			-10	μA	V <sub>IN</sub> = 0 V	
<b>IN<sub>tsp3</sub> - 3.3 V TTL level Schmitt-triggered input pin</b>							
Input Low Threshold Voltage	V <sub>t-</sub>	0.5	0.8	1.1	V	V <sub>DD</sub> = 3.3 V	
Input High Threshold Voltage	V <sub>t+</sub>	1.6	2.0	2.4	V	V <sub>DD</sub> = 3.3 V	
Hysteresis	V <sub>TH</sub>	0.5	1.2		V	V <sub>DD</sub> = 3.3 V	
Input High Leakage	I <sub>LH</sub>			+10	μA	V <sub>IN</sub> = 3.3 V	
Input Low Leakage	I <sub>LL</sub>			-10	μA	V <sub>IN</sub> = 0 V	

## 15. APPLICATION CIRCUITS

### 15.1 Parallel Port Extension FDD

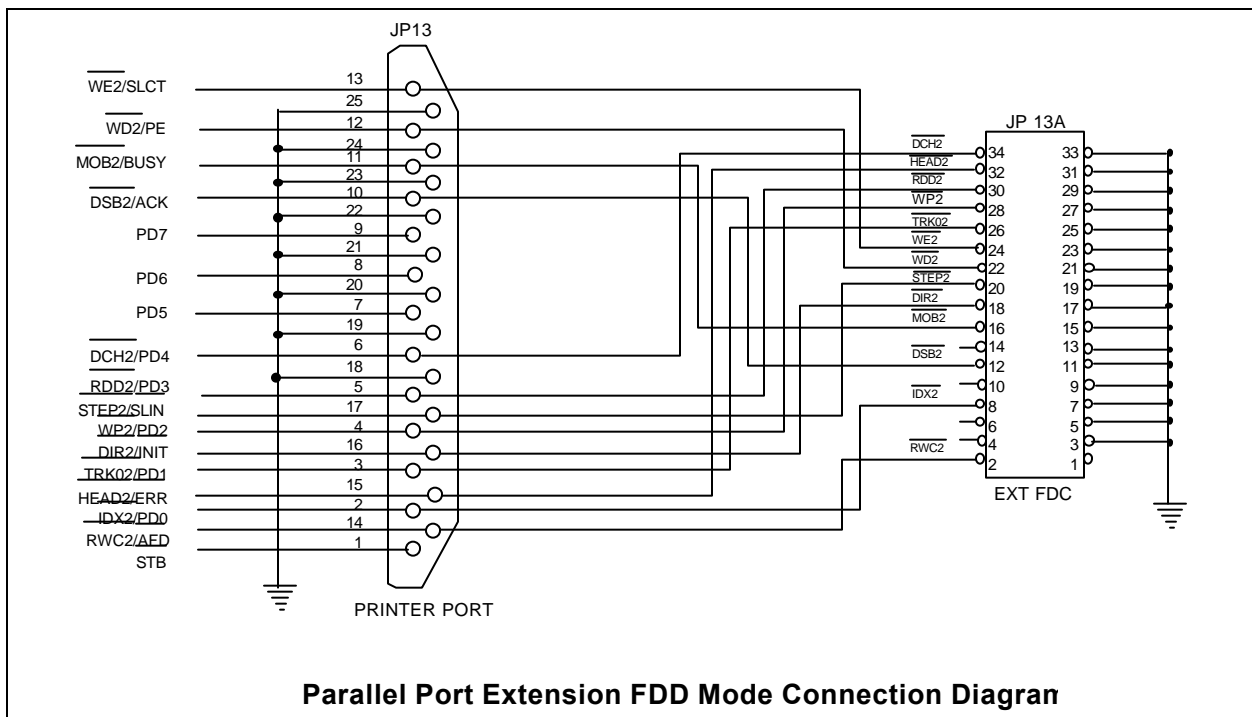



## 15.2 Parallel Port Extension 2FDD

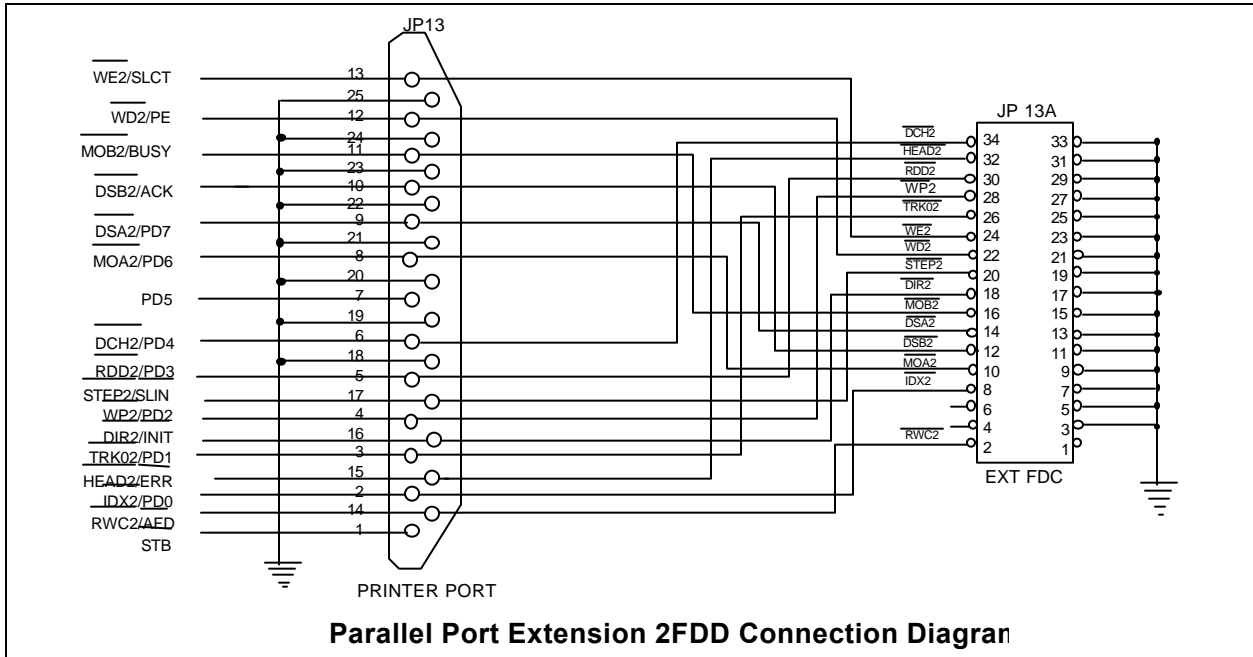

## 15.3 Four FDD Mode

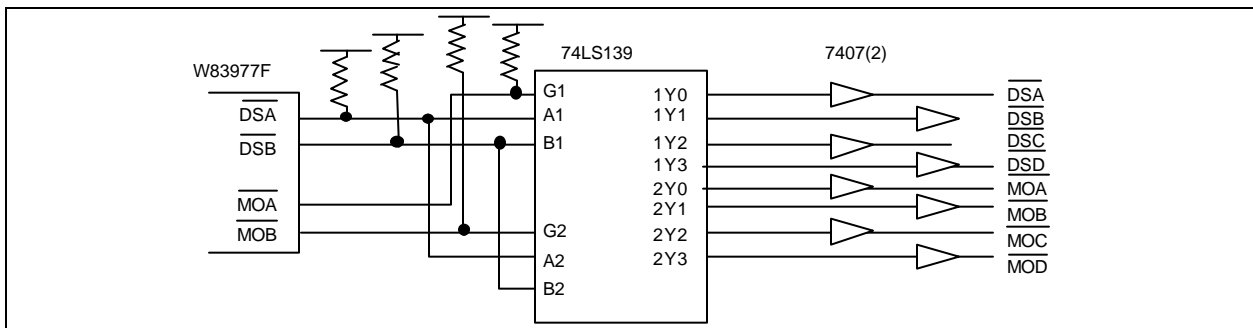



**PRELIMINARY**

## 16. ORDERING INSTRUCTION

PART NO.	KBC FIRMWARE	REMARKS
W83627SF-AW	AMIKEY-2™	
W83627SF-PW	Phoenix MultiKey/42™	Only support 12MHz KBC clock input

## 17. HOW TO READ THE TOP MARKING

Example: The top marking of W83627SF-AW



1st line: Winbond logo

2nd line: the type number: W83627SF-AW

3rd line: the source of KBC F/W -- American Megatrends Incorporated™

4th line: the tracking code 821 A 2 C 282012345

821: packages made in '98, week 21

A: assembly house ID; A means ASE, S means SPIL.... etc.

2: Winbond internal use.

B: IC revision; A means version A, B means version B

282012345: wafer production series lot number

## 18. PACKAGE DIMENSIONS

(128-pin QFP)

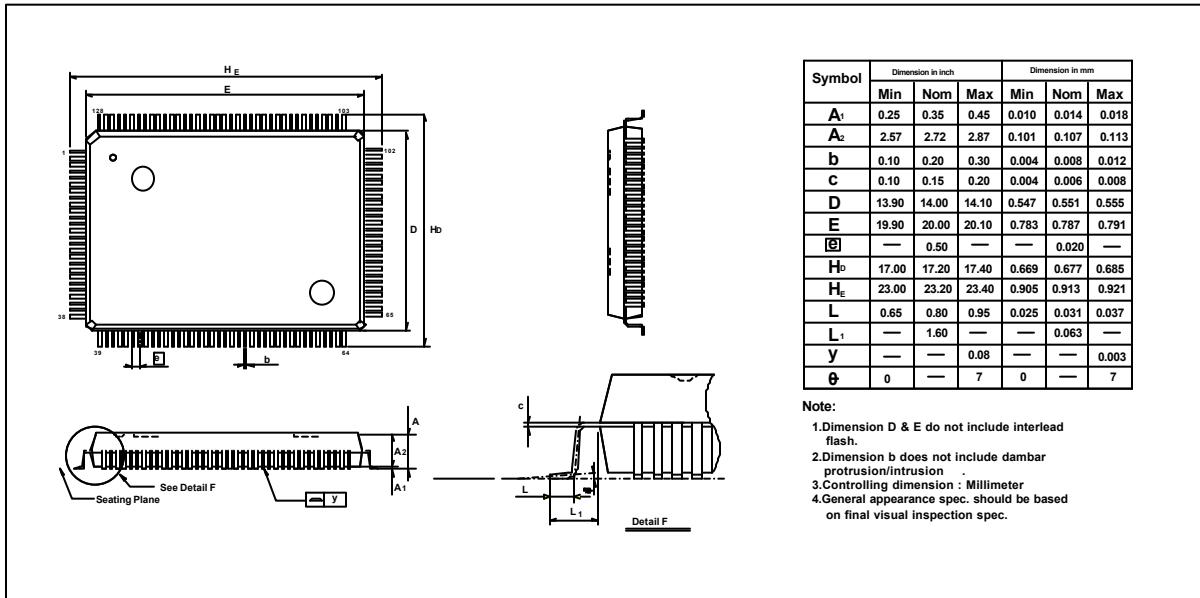

**Headquarters**  
 No. 4, Creation Rd. III  
 Science-Based Industrial Park  
 Hsinchu, Taiwan  
 TEL: 886-35-770066  
 FAX: 886-35-789467  
 www: <http://www.winbond.com.tw/>

**Winbond Electronics (H.K.) Ltd.**  
 Rm. 803, World Trade Square, Tower II  
 123 Hoi Bun Rd., Kwun Tong  
 Kowloon, Hong Kong  
 TEL: 852-27516023-7  
 FAX: 852-27552064

**Winbond Electronics (North America) Corp.**  
 2730 Orchard Parkway  
 San Jose, CA 95134 U.S.A.  
 TEL: 1-408-9436666  
 FAX: 1-408-9436668

**Taipei Office**  
 11F, No. 115, Sec. 3, Min-Sheng East Rd.  
 Taipei, Taiwan  
 TEL: 886-2-7190505  
 FAX: 886-2-7197502  
 TLX: 16485 WINTPE

Note: All data and specifications are subject to change without notice.