

8961724 TEXAS INSTR (LIN/INTFC)

91D 75047 D

**SN75491, SN75491A, SN75492, SN75492A
MOS-TO-LED DRIVERS**

D2355, OCTOBER 1972—REVISED SEPTEMBER 1986

**QUAD SEGMENT DRIVER AND HEX DIGIT DRIVER FOR INTERFACING
BETWEEN MOS AND LIGHT-EMITTING-DIODE (LED) DISPLAYS**

T-52-13-07

- 50-mA Source or Sink Capability ('491, '491A)
- 250-mA Sink Capability ('492, '492A)
- Rated for 10-V Operation ('491, '492)
- Rated for 20-V Operation ('491A, '492A)
- Low Input Current for MOS Compatibility
- Low Standby Power
- High-Gain Darlington Circuits

description

The SN75491, SN75491A, SN75492, and SN75492A are monolithic integrated circuits designed to be used together with MOS integrated circuits and common-cathode LED's in serially addressed multi-digit displays. This time-multiplexed system, which uses a segment-address-and-digit-scan method of LED drive, minimizes the number of drivers required.

The SN75491 and SN75491A are quadruple segment drivers. The SN75492 and SN75492A are hex digit drivers. The SN75491 and SN75492 are characterized for operation to 10 volts. The SN75491A and SN75492A are characterized for operation to 20 volts.

The SN75491, SN75491A, SN75492, and SN75492A are characterized for operation from 0°C to 70°C.

logic diagram (each driver)

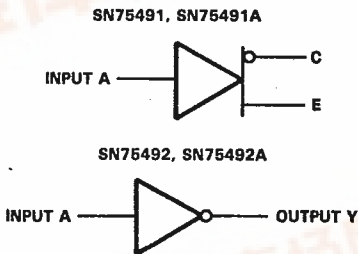

SN75491, SN75491A
N DUAL-IN-LINE PACKAGE

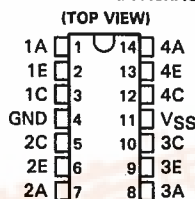

SN75492, SN75492A
N DUAL-IN-LINE PACKAGE

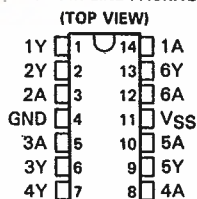

logic symbols†

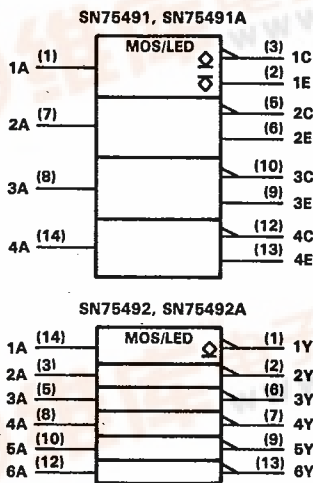

† These symbols are in accordance with ANSI/IEEE Std 91-1984 and IEC Publication 617-12.

PRODUCTION DATA documents contain information current as of publication date. Products conform to specifications per the terms of Texas Instruments standard warranty. Production processing does not necessarily include testing of all parameters.

Copyright © 1986, Texas Instruments Incorporated

**TEXAS
INSTRUMENTS**

POST OFFICE BOX 685012 • DALLAS, TEXAS 75269

3
Display Drivers



8961724 TEXAS INSTR (LIN/INTFC)

91D 75048 D

**SN75491, SN75491A, SN75492, SN75492A
MOS-TO-LED DRIVERS**

T-52-13-07

schematics

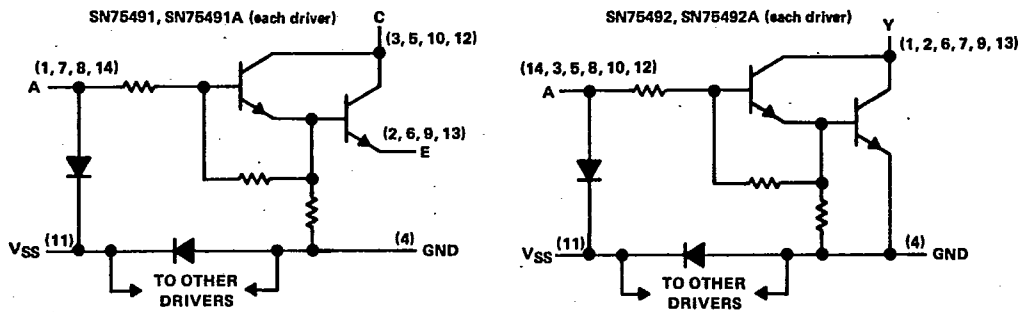

Display Drivers

absolute maximum ratings over operating free-air temperature range (unless otherwise noted)

	SN75491	SN75491A	SN75492	SN75492A	UNIT
Input voltage range (see Notes 1 and 2)	-5 V to V _{SS}	-5 V to V _{SS}	-5 V to V _{SS}	-5 V to V _{SS}	
Collector (output) voltage, V _C	10	20	10	20	V
Collector (output)-to-input voltage	10	20	10	20	V
Emitter-to-ground voltage (V _I ≥ 5 V)	10	20			V
Emitter-to-input voltage	5	5			V
Voltage at V _{SS} terminal with respect to any other device terminal	10	20	10	20	V
Collector (output) current, I _C	Each collector (output)	50	50	250	mA
	All collectors (outputs)	200	200	600	
Continuous total dissipation at (or below) 25°C free-air temperature (see Note 3)	875	875	875	875	mW
Operating free-air temperature range	0 to 70	0 to 70	0 to 70	0 to 70	°C
Storage temperature range	-65 to 150	-65 to 150	-65 to 150	-65 to 150	°C
Lead temperature 1,6 mm (1/16 inch) from case for 10 seconds	260	260	260	260	°C

- NOTES: 1. All voltage values are with respect to network ground terminal.
 2. The input is the only device terminal that may be negative with respect to ground.
 3. For operation at 25°C free-air temperature, refer to Dissipation Derating Curves in Appendix A. For these devices in the N package, use the 7-mW/°C curve.

'491, '491A electrical characteristics, V_{SS} = 10 V for SN75491, V_{SS} = 20 V for SN75491A, T_A = 0°C to 70°C (unless otherwise noted)

PARAMETER	TEST CONDITIONS	MIN	TYP†	MAX	UNIT
V _{CE(on)} On-State collector-emitter voltage	Input = 8.5 V through 1 kΩ, V _E = 5 V, I _C = 60 mA, T _A = 25°C		0.9	1.2	V
	Input = 8.5 V through 1 kΩ, V _E = 5 V, I _C = 50 mA			1.5	
I _{C(off)} Off-state collector current	V _C = V _{SS} , V _E = 0, I _I = 40 μA			100	μA
	V _C = V _{SS} , V _E = 0, V _I = 0.7 V			100	
I _I Input current at maximum input voltage	V _I = V _{SS} , V _E = 0, I _C = 20 mA	'491	2.2	3.3	mA
		'491A	4.7	6.5	
I _E Emitter reverse current	V _I = 0, V _E = 5 V, I _C = 0			100	μA
I _{SS} Current into V _{SS} terminal				1	mA

†All typical values are at T_A = 25°C.

8961724 TEXAS INSTR (LIN/INTFC)

91D 75049 D

**SN75491, SN75491A, SN75492, SN75492A
MOS-TO-LED DRIVERS**

T-52-13-07

'492, '492A electrical characteristics, $V_{SS} = 10\text{ V}$ for SN75492, $V_{SS} = 20\text{ V}$ for SN75492A, $T_A = 0^\circ\text{C}$ to 70°C (unless otherwise noted)

PARAMETER	TEST CONDITIONS	MIN	TYP†	MAX	UNIT
VOL Low-level output voltage	Input = 6.5 V through 1 k Ω , $I_{OL} = 250\text{ mA}$, $T_A = 25^\circ\text{C}$	0.9	1.2		V
	Input = 6.5 V through 1 k Ω , $I_{OL} = 250\text{ mA}$			1.5	
IOH High-level output current	$V_{OH} = V_{SS}$, $V_I = 40\ \mu\text{A}$			200	μA
	$V_{OH} = V_{SS}$, $V_I = 0.5\text{ V}$			200	
II Input current at maximum input voltage	$V_I = V_{SS}$, $I_{OL} = 20\text{ mA}$	'492	2.2	3.3	mA
		'492A	4.7	6.5	
ISS Current into VSS terminal				1	mA

†All typical values are at $T_A = 25^\circ\text{C}$.

SN75491, SN75491A switching characteristics, $V_{SS} = 7.5\text{ V}$, $T_A = 25^\circ\text{C}$

PARAMETER	TEST CONDITIONS	MIN	TYP	MAX	UNIT
tPLH Propagation delay time, low-to-high-level output (collector)	$V_{IH} = 4.5\text{ V}$, $V_E = 0$,		100		ns
tPHL Propagation delay time, high-to-low-level output (collector)	$R_L = 200\ \Omega$, $C_L = 15\text{ pF}$		20		ns

SN75492, SN75492A switching characteristics, $V_{SS} = 7.5\text{ V}$, $T_A = 25^\circ\text{C}$

PARAMETER	TEST CONDITIONS	MIN	TYP	MAX	UNIT
tPLH Propagation delay time, low-to-high-level output	$V_{IH} = 7.5\text{ V}$, $R_L = 39\ \Omega$,		300		ns
tPHL Propagation delay time, high-to-low-level output	$C_L = 15\text{ pF}$		30		ns

PARAMETER MEASUREMENT INFORMATION

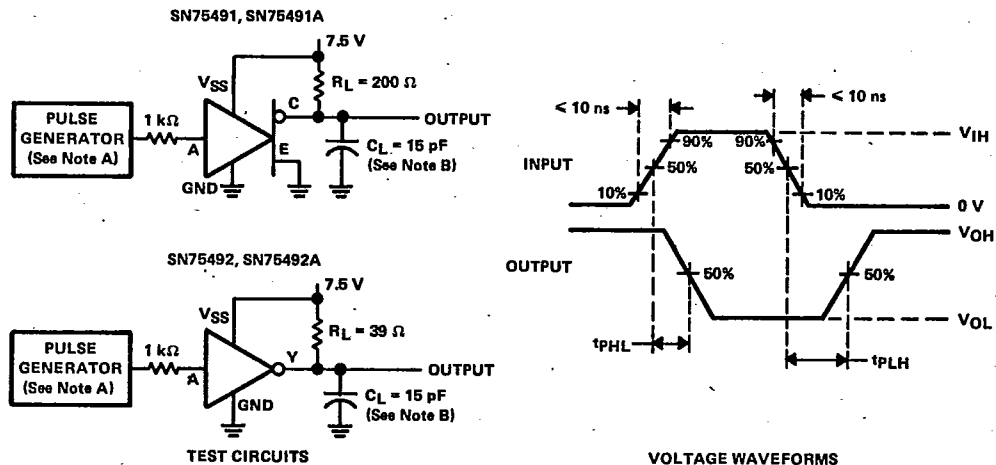

NOTES: A. The pulse generator has the following characteristics: $Z_{out} = 50\ \Omega$, $PRR \leq 100\text{ kHz}$, $t_w = 1\ \mu\text{s}$.
B. C_L includes probe and jig capacitance.

FIGURE 1. PROPAGATION DELAY TIMES

3
Display Drivers

8961724 TEXAS INSTR (LIN/INTFC)

91D 75050 D

**SN75491, SN75491A, SN75492, SN75492A
MOS-TO-LED DRIVERS**

T-52-13-07

TYPICAL CHARACTERISTICS

**3
Display Drivers**

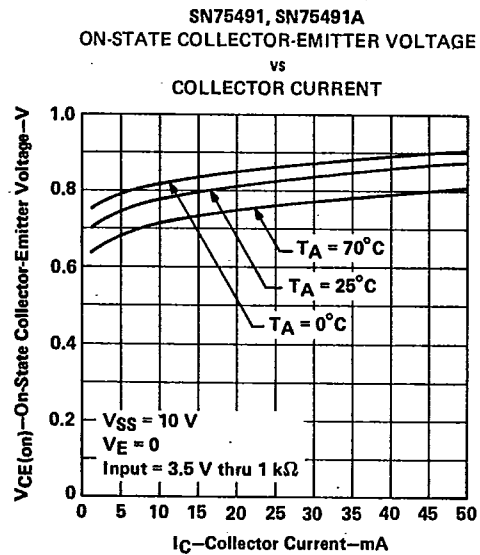
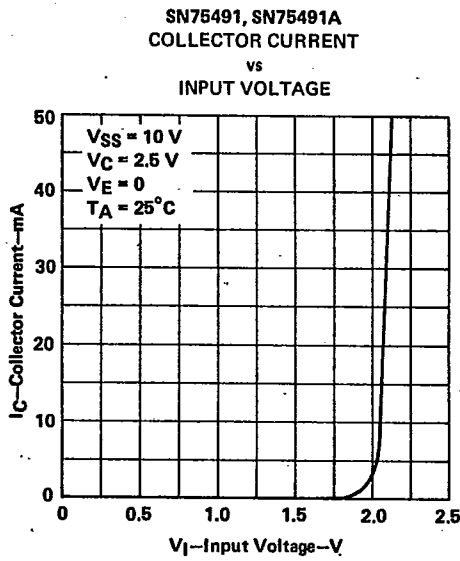
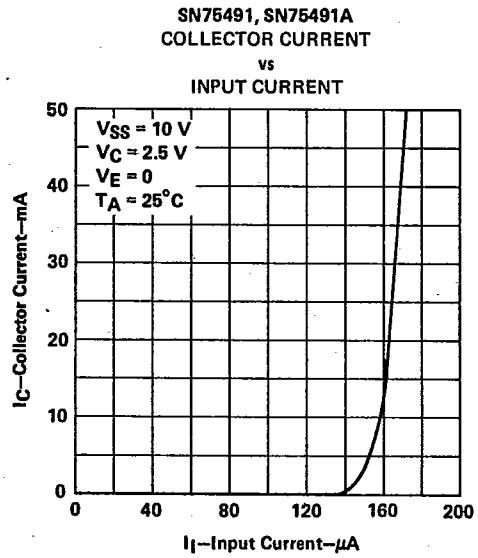
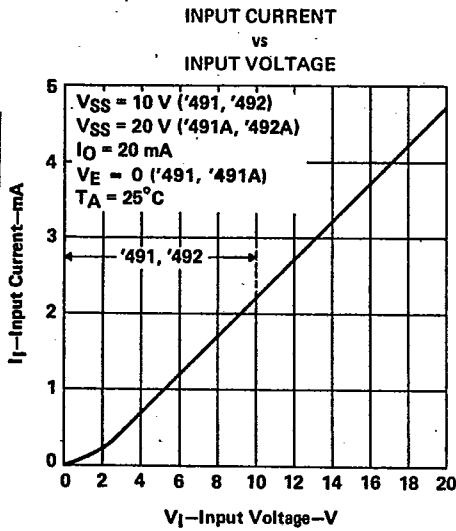

8961724 TEXAS INSTR (LIN/INTFC) 91D 75051 D

**SN75491, SN75491A, SN75492, SN75492A
MOS-TO-LED DRIVERS**

T-52-13-07

TYPICAL CHARACTERISTICS

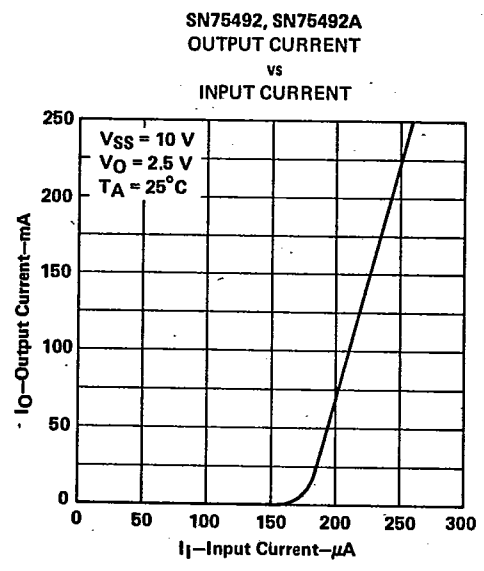

FIGURE 6

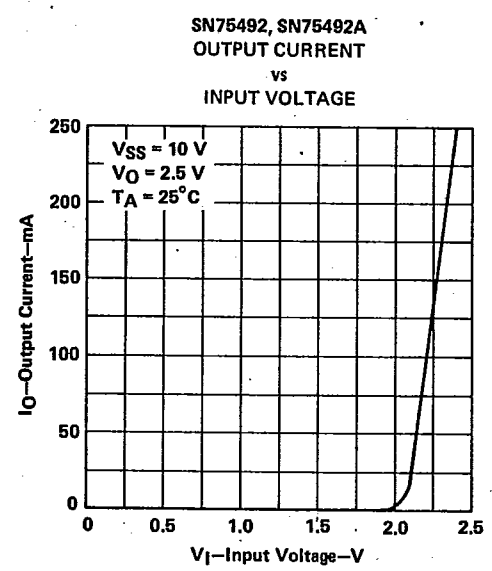

FIGURE 7

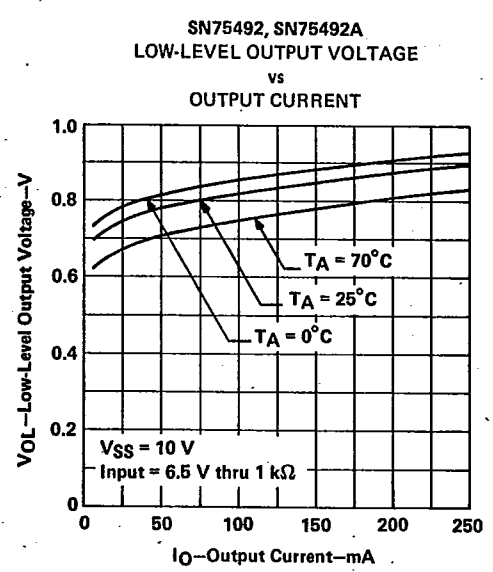

FIGURE 8

3
Display Drivers

8961724 TEXAS INSTR (LIN/INTFC)

91D 75052 D

**SN75491, SN75491A, SN75492, SN75492A
MOS-TO-LED DRIVERS**

T-52-13-07

TYPICAL APPLICATION DATA

Figure 9 is an example of time multiplexing the individual digits in a display to minimize circuitry. Up to twelve digits, each of which use a seven-segment display with decimal point, may be displayed using only two SN75491 and two SN75492 drivers.

3
Display Drivers

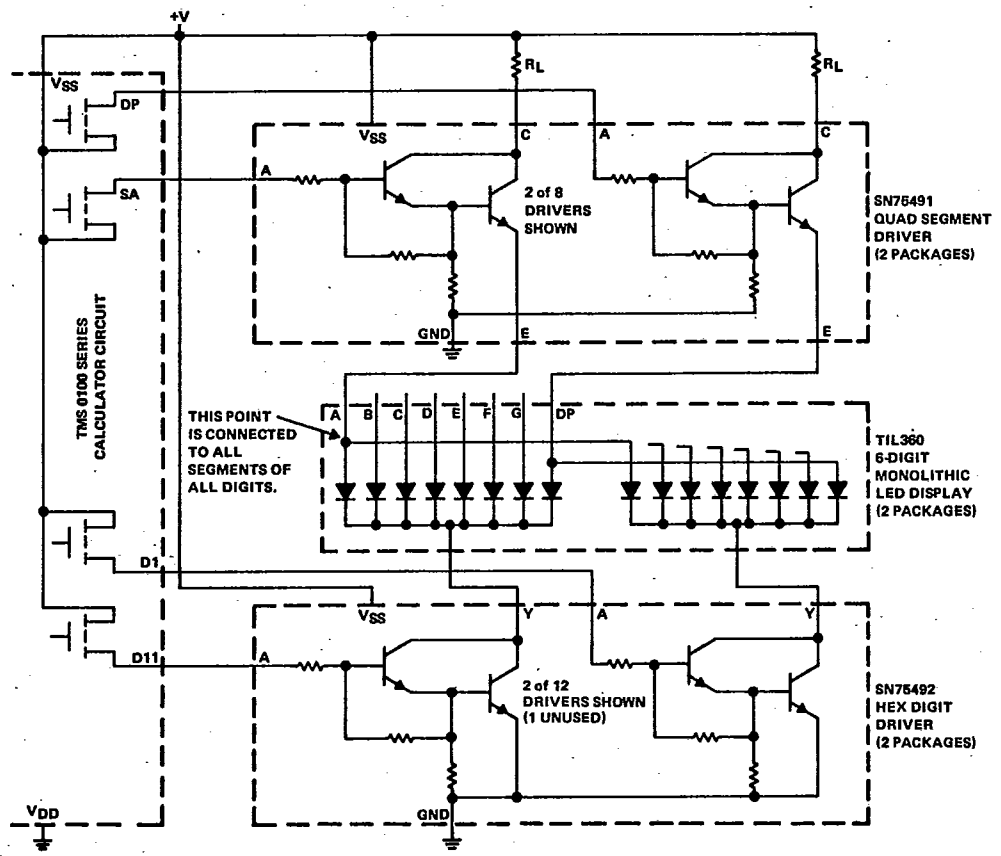

FIGURE 9. INTERFACING BETWEEN MOS CALCULATOR CIRCUIT AND LED MULTI-DIGIT DISPLAY

**SN75491, SN75491A, SN75492, SN75492A
MOS-TO-LED DRIVERS**

T-52-13-07

TYPICAL APPLICATION DATA

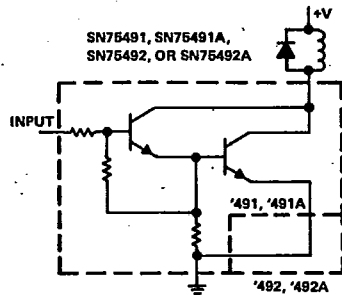

FIGURE 10. QUAD OR HEX RELAY DRIVER

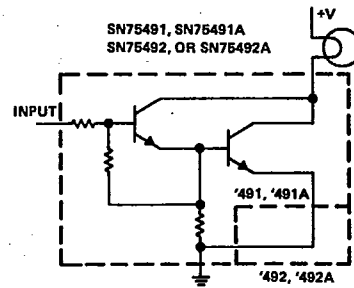

FIGURE 11. QUAD OR HEX LAMP DRIVER

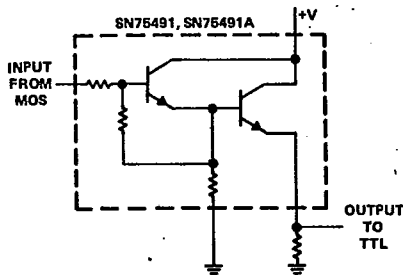

FIGURE 12. MOS-TO-TTL LEVEL SHIFTER

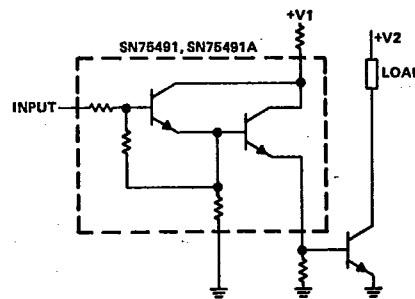
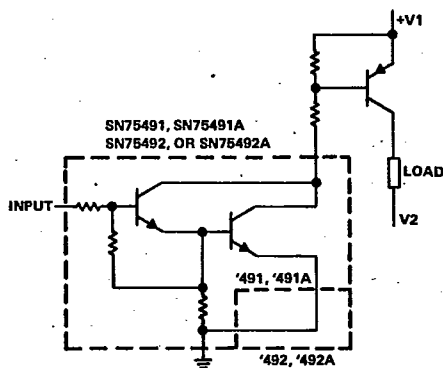

FIGURE 13. QUAD HIGH-CURRENT N-P-N TRANSISTOR DRIVER



NOTE A: This circuit may be used as a digit driver for common-mode LED displays.

FIGURE 14. QUAD OR HEX HIGH-CURRENT P-N-P TRANSISTOR DRIVER

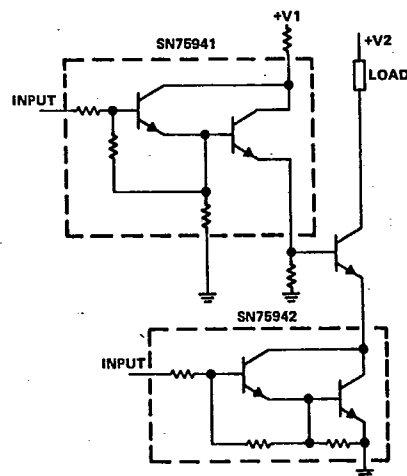

FIGURE 15. BASE/EMITTER SELECT N-P-N TRANSISTOR DRIVER

3
Display Drivers

8961724 TEXAS INSTR (LIN/INTFC)

91D 75054 D

SN75491, SN75491A, SN75492, SN75492A
MOS-TO-LED DRIVERS

T-52-13-07

TYPICAL APPLICATION DATA

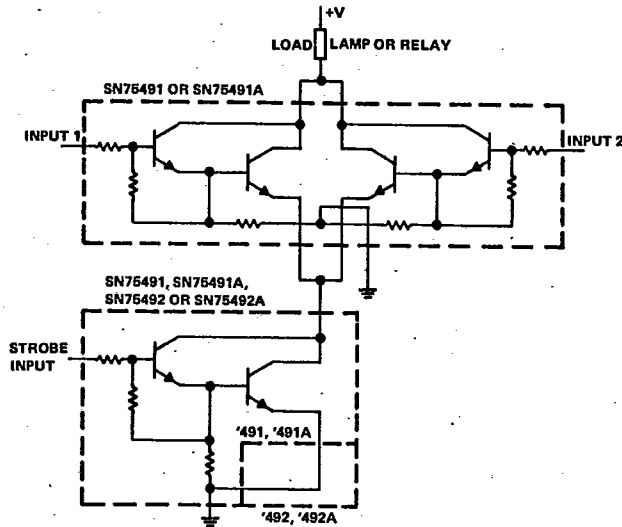

FIGURE 16. STROBED "NOR" DRIVER

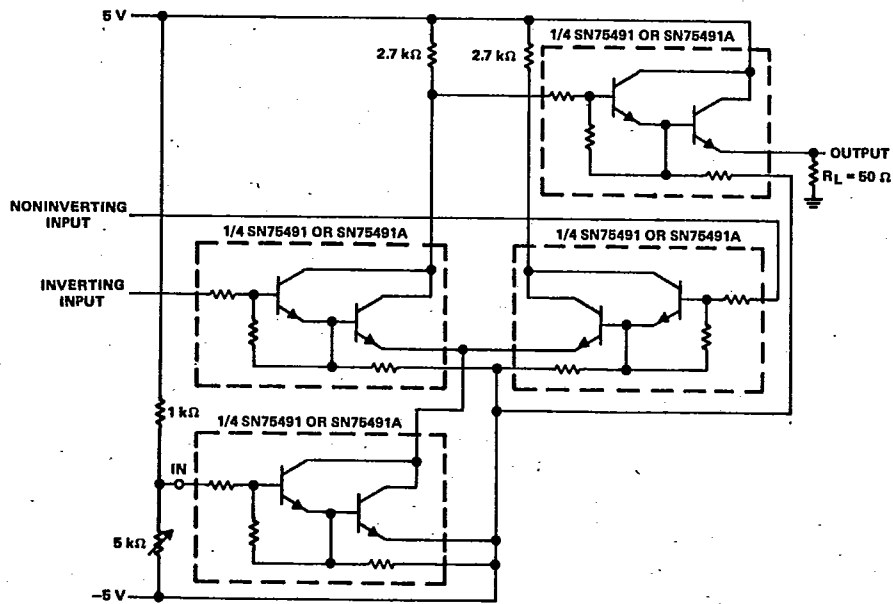

FIGURE 17. SN75491/SN75491A USED AS AN INTERFACE CIRCUIT BETWEEN THE BALANCED 30-MHz OUTPUT OF AN RF AMPLIFIER AND A COAXIAL CABLE

3
Display Drivers