



NJM2870

LOW DROPOUT VOLTAGE REGULATOR

■ GENERAL DESCRIPTION

The NJM2870 is low dropout voltage regulator designed for cellular phone application.

Advanced Bipolar technology achieves low noise, high ripple rejection and low quiescent current.

■ PACKAGE OUTLINE



NJM2870F

■ FEATURES

- High Ripple Rejection $56\text{dB} \leq \text{RR} \text{ (DC} < f < 60\text{kHz)}$
66dB typ. (f=100Hz)
60dB typ. (f=1kHz)
- Output Noise Voltage $V_{\text{no}}=30\mu\text{V} \text{ (Cp}=0.01\mu\text{F)}$
- Output Current $I_{\text{o(max)}}=150\text{mA}$
- High Precision Output $V_{\text{o}}\pm 2\%$
- Low Dropout Voltage $\Delta V_{\text{I-O}}=0.12\text{V typ. At } I_{\text{o}}=60\text{mA}$
- ON/OFF Control (Active High)
- Internal Short Circuit Current Limit
- Internal Thermal Overload Protection
- Bipolar Technology
- Package Outline MTP5 (MTP5:2.8x2.9x1.1)

■ PIN CONFIGURATION

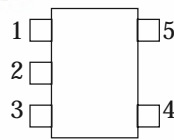

NJM2870F

PIN FUNCTION

1. CONTROL (Active High)
2. GND
3. NOISE BYPASS
4. V_{OUT}
5. V_{IN}

■ EQUIVALENT CIRCUIT

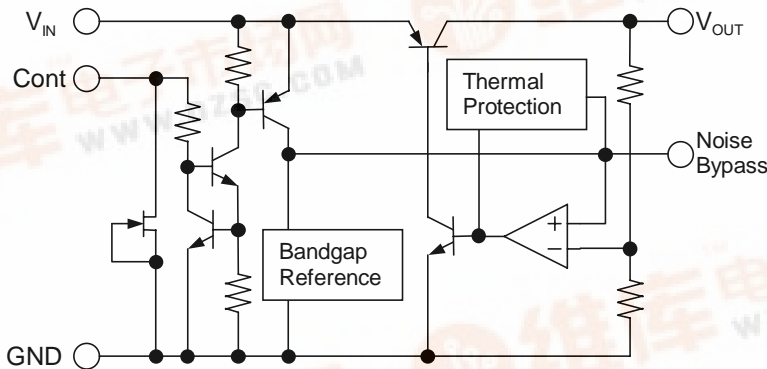

■ OUTPUT VOLTAGE RANK LIST

Device Name	V_{OUT}
NJM2870F18	1.8V
NJM2870F19	1.9V
NJM2870F02	2.0V
NJM2870F21	2.1V
NJM2870F25	2.5V
NJM2870F27	2.7V
NJM2870F28	2.8V

Device Name	V_{OUT}
NJM2870F285	2.85V
NJM2870F29	2.9V
NJM2870F03	3.0V
NJM2870F31	3.1V
NJM2870F32	3.2V
NJM2870F33	3.3V
NJM2870F34	3.4V

Device Name	V_{OUT}
NJM2870F35	3.5V
NJM2870F38	3.8V
NJM2870F04	4.0V
NJM2870F45	4.5V
NJM2870F46	4.6V
NJM2870F05	5.0V



■ ABSOLUTE MAXIMUM RATINGS (Ta=25°C)

PARAMETER	SYMBOL	RATINGS	UNIT
Input Voltage	V_{IN}	+14	V
Control Voltage	V_{CONT}	+14(note 1)	V
Power Dissipation	P_D	200	mW
Operating Temperature	T_{opr}	-40 ~ +85	°C
Storage Temperature	T_{stg}	-40 ~ +125	°C

(note 1)When input voltage is less than +14V, the absolute maximum control voltage is equal to the input voltage.

■ ELECTRICAL CHARACTERISTICS ($V_{IN}=V_o+1V$, $C_{IN}=0.1\mu F$, $C_o=4.7\mu F$, $C_p=0.01\mu F$, $T_a=25^\circ C$)

PARAMETER	SYMBOL	TEST CONDITION	MIN.	TYP.	MAX.	UNIT
Output Voltage	V_o	$I_o=30mA$	-2%	-	+2%	V
Quiescent Current	I_Q	$I_o=0mA$, expect I_{cont}	-	200	300	μA
Quiescent Current at Control OFF	$I_{Q(OFF)}$	$V_{CONT}=0V$	-	-	100	nA
Output Current	I_o	$V_o=0.3V$	150	200	-	mA
Line Regulation	$\Delta V_o/\Delta V_{IN}$	$V_{IN}=V_o+1V \sim V_o+6V$, $I_o=30mA$	-	-	0.10	%/V
Load Regulation	$\Delta V_o/\Delta I_o$	$I_o=0 \sim 100mA$	-	-	0.03	%/mA
Dropout Voltage	ΔV_{I-O}	$I_o=60mA$	-	0.12	0.2	V
Ripple Rejection	RR	$e_{in}=200mV_{rms}$, $f=1kHz$, $I_o=10mA$ $V_{IN}=V_o+2V$, $V_o=3V$ Version	-	60	-	dB
Average Temperature Coefficient of Output Voltage	$\Delta V_o/\Delta T_a$	$T_a=0\sim 85^\circ C$, $I_o=10mA$	-	0.2	-	mV/°C
Output Noise Voltage	V_{NO}	$f=10Hz\sim 80kHz$, $I_o=10mA$, $V_o=3V$ Version	-	30	-	μV_{rms}
Control Voltage for ON-state	$V_{CONT(ON)}$		1.6	-	-	V
Control Voltage for OFF-state	$V_{CONT(OFF)}$		-	-	0.6	V

(note 2)Please confirm the specification separately because some parameters depend on output voltage.

■ TEST CIRCUIT

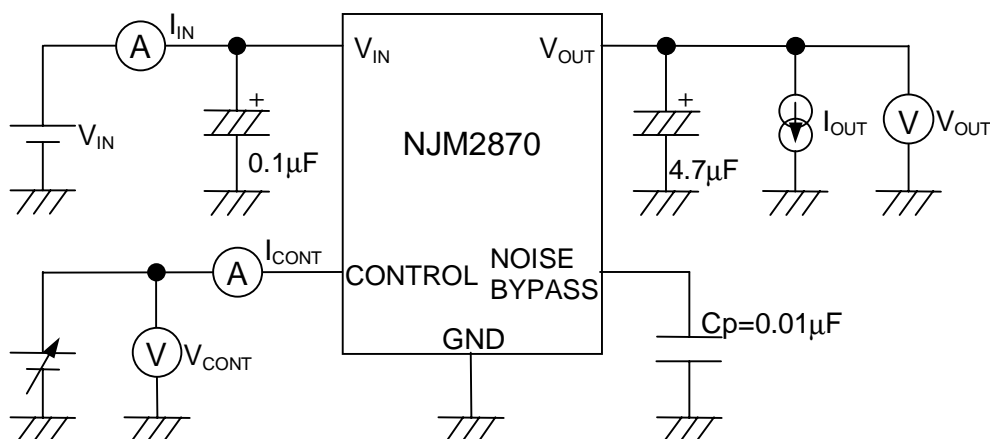

■ TYPICAL APPLICATION

① In the case where ON/OFF Control is not required:

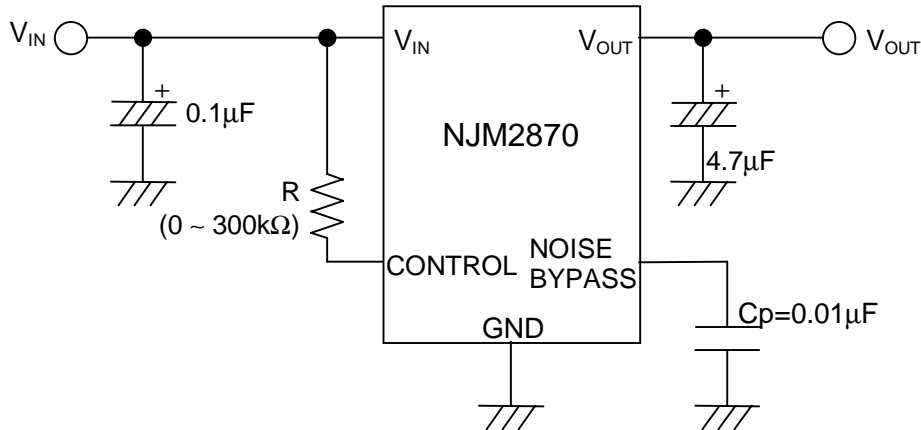

Connect control terminal(1Pin) to V_{IN} terminal(5Pin)

In case a resistance "R" is used, the quiescent current will be decreased. However, the but minimum operating voltage will be increase as well. Please refer to a figure of Output Voltage vs. Control Voltage.

② In use of ON/OFF CONTROL:

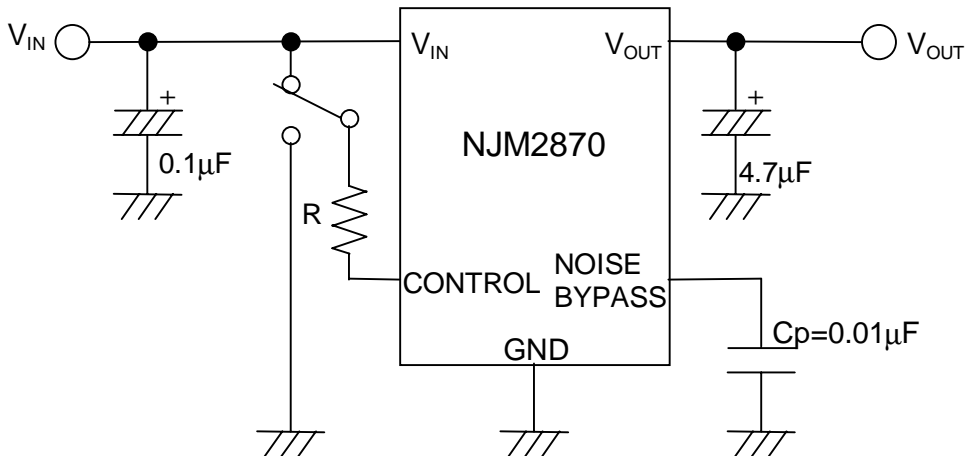

In case the control terminal is "H", the output is enabled.

The control terminal is "L" or "open", the output is disabled.

★Noise bypass Capacitance C_p

Noise bypass capacitance C_p reduces noise generated by band-gap reference circuit.

Noise level and ripple rejection will be improved when larger C_p is used. Please refer to the typical characteristics to determine the value.

Use of smaller C_p value may induce oscillation.

Please make sure to use C_p value of greater than 0.01uF to avoid the problem.



[CAUTION]

The specifications on this databook are only given for information, without any guarantee as regards either mistakes or omissions. The application circuits in this databook are described only to show representative usages of the product and not intended for the guarantee or permission of any right including the industrial rights.