



U4090B-P

Monolithic Integrated Feature Phone Circuit

Description

The μ -controlled telephone circuit U4090B-P is a linear integrated circuit for use in feature phones, answering machines and fax machines. It contains the speech circuit, tone ringer interface with DC/DC converter, sidetone equivalent and ear protection rectifiers. The circuit is line powered and contains all components necessary for amplification of signals and adaptation to the line.

An integrated voice switch with loudspeaker amplifier allows loudhearing or hands-free operation. With an anti-feedback function, acoustical feedback during loudhearing can be reduced significantly. The generated supply voltage is suitable for a wide range of peripheral circuits.

Features

- DC characteristic adjustable
- Transmit and receive gain adjustable
- Symmetrical input of microphone amplifier
- Anti-clipping in transmit direction
- Automatic line-loss compensation
- Symmetrical output of earpiece amplifier
- Built-in ear protection
- DTMF and MUTE input
- Adjustable sidetone suppression independent of sending and receiving amplification
- Speech circuit with two sidetone networks
- Built-in line detection circuit
- Integrated amplifier for loudhearing operation
- Anti-clipping for loudspeaker amplifier
- Improved acoustical feedback suppression
- Power down
- Voice switch
- Tone ringer interface with dc/dc converter

- Zero crossing detection
- Common speaker for loudhearing and tone ringer
- Supply voltages for all functional blocks of a subscriber set
- Integrated transistor for short circuiting the line voltage
- Answering machine interface
- Operation possible from -10 mA line currents
- Filters against EMI on critical I/O

Benefits

- Savings of one piezo-electric transducer
- Complete system integration of analog signal processing on one chip
- Very few external components
- Less components for EMI-protection

Applications

Feature phone, answering machine, fax machine, speaker phone

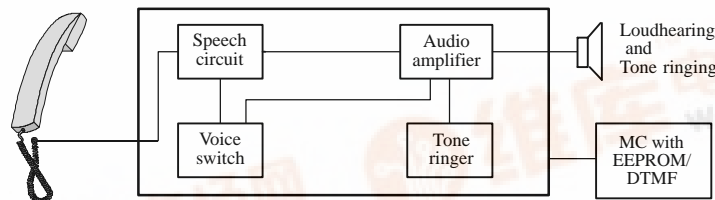

94 8741

Ordering Information

Extended Type Number	Package	Remarks
U4090B-PFN	SSO44	Tubes
U4090B-PFNG3	SSO44	Taped and reeled



Detailed Block Diagram

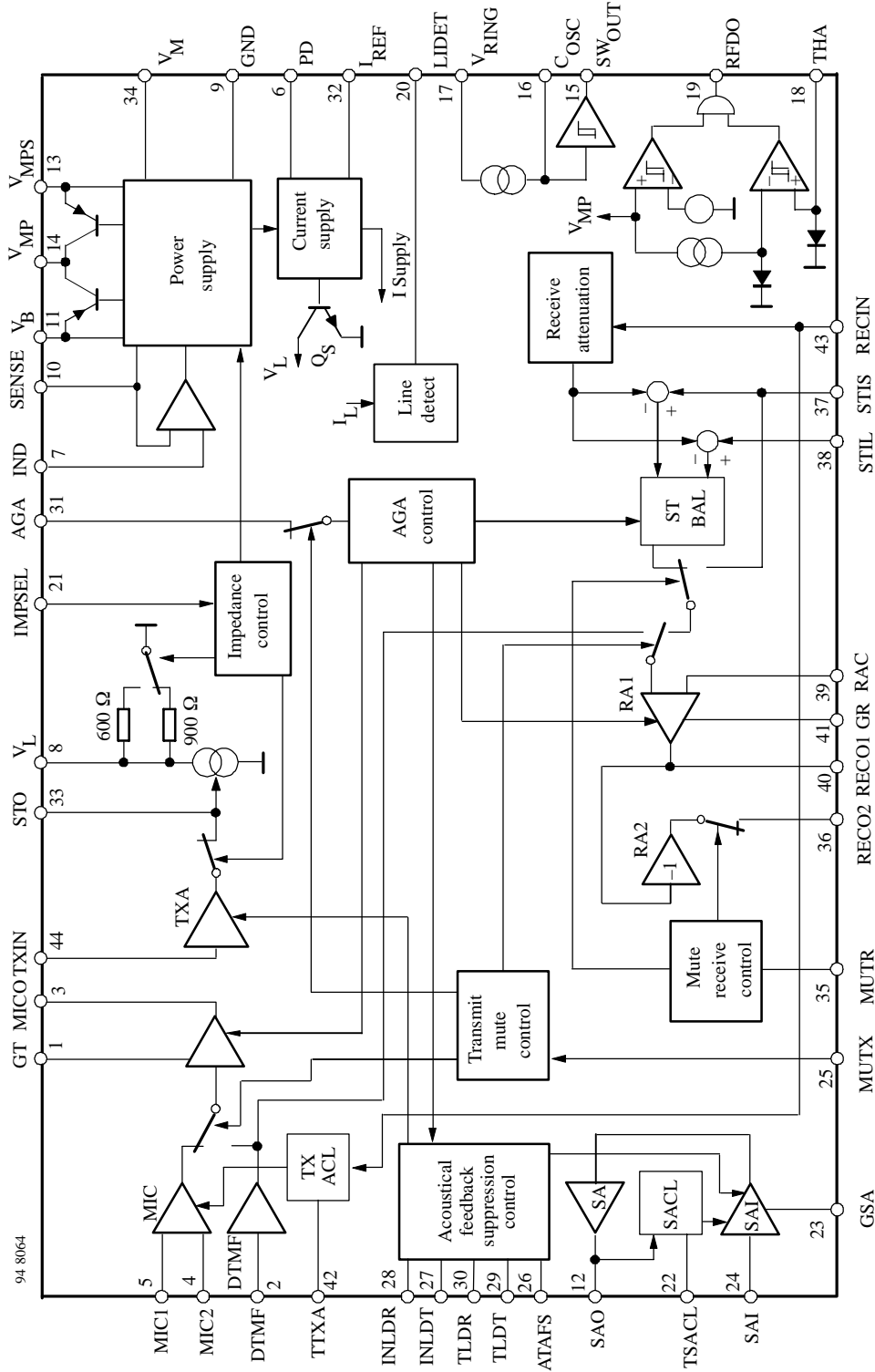
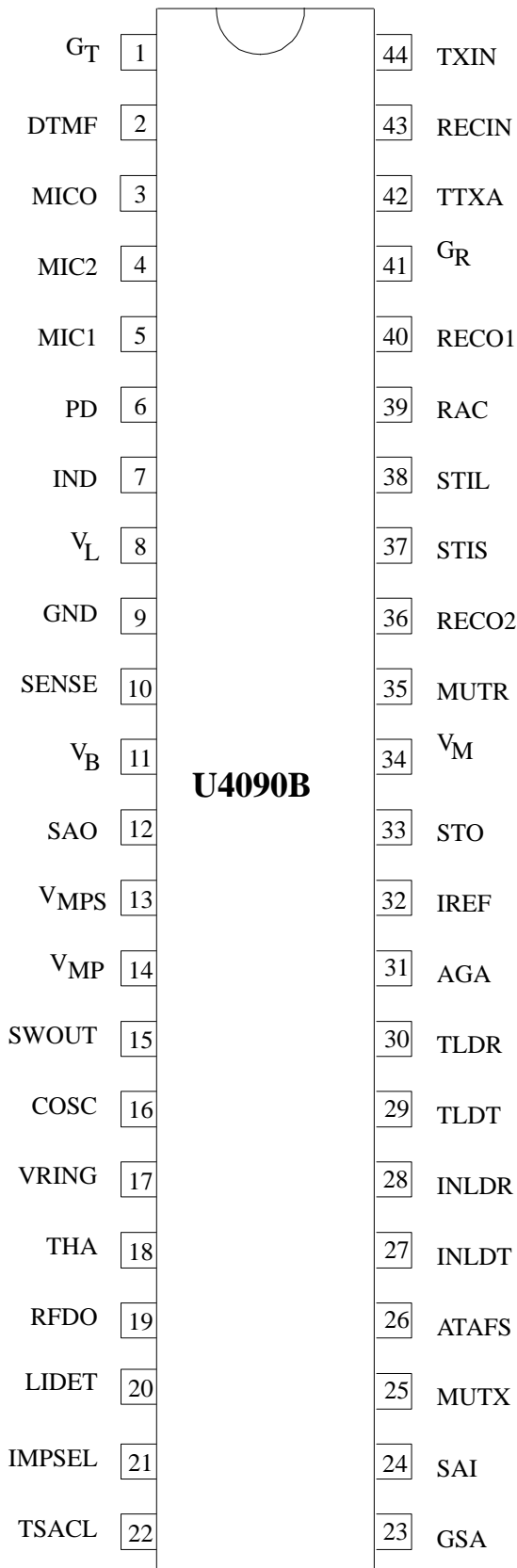

Figure 1. Detailed block diagram



Pin Description

Pin	Symbol	Function
1	GT	A resistor from this pin to GND sets the amplification of microphone and DTMF signals, the input amplifier can be muted by applying VMP to GT.
2	DTMF	Input for DTMF signals, also used for the answering machine and hands-free input
3	MICO	Output of microphone preamplifier
4	MIC 2	Non-inverting input of microphone amplifier
5	MIC 1	Inverting input of microphone amplifier
6	PD	Active high input for reducing the current consumption of the circuit, simultaneously VL is shorted by an internal switch
7	IND	The internal equivalent inductance of the circuit is proportional to the value of the capacitor at this pin, a resistor connected to ground may be used to reduce the dc line voltage
8	VL	Line voltage
9	GND	Reference point for dc- and ac-output signals
10	SENSE	A small resistor (fixed) connected from this pin to VL sets the slope of the dc characteristic and also effects the line-length equalization characteristics and the line current at which the loudspeaker amplifier is switched on
11	VB	Unregulated supply voltage for peripheral circuits (voice switch), limited to typically 7 V
12	SAO	Output of loudspeaker amplifier
13	VMPS	Unregulated supply voltage for μC, limited to 6.3 V
14	VMP	Regulated supply voltage 3.3 V for peripheral circuits (especially microprocessors), minimum output current: 2 mA (ringing) 4 mA (speech mode)
15	SWOUT	Output for driving external switching transistor
16	COSC	40-kHz oscillator for ringing power converter

94 7905 e

Pin Description (continued)

Pin	Symbol	Function
17	V _{RING}	Input for ringing signal protected by internal zener diode
18	THA	Threshold adjustment for ringing frequency detector
19	RFDO	Output of ringing frequency detector
20	LIDET	Line detect; output is low when the line current is more than 15 mA
21	IMP-SEL	Control input for selection of line impedance 1. 600 Ω 2. 900 Ω 3. Mute of second transmit stage (TXA); also used for indication of external supply (answering machine); last chosen impedance is stored
22	TSACL	Time constant of anti-clipping of speaker amplifier
23	GSA	Current input for setting the gain of the speaker amplifier, adjustment characteristic is logarithmical, or RGSA > 2 MΩ, the speaker amplifier is switched off
24	SA I	Speaker amplifier input (for loudspeaker, tone ringer and hands-free use)
25	MUTX	Three-state input of transmit mute: 1) Speech condition; inputs MIC1 / MIC2 active 2) DTMF condition; input DTMF active a part of the input signal is passed to the receiving amplifier as a confidence signal during dialing 3) Input DTMF used for answering machine and hands-free use; receive branch not affected
26	ATAFS	Attenuation of acoustical feedback suppression, maximum attenuation of AFS circuit is set by a resistor at this pin, without the resistor, AFS is switched off
27	INLDT	Input of transmit level detector
28	INLDR	Input of receive level detector

Pin	Symbol	Function
29	TLDT	Time constant of transmit level detector
30	TLDR	Time constant of receive level detector
31	AGA	Automatic gain adjustment with line current a resistor connected from this pin to GND sets the starting point max. gain change: 6 dB.
32	IREF	Internal reference current generation; RREF = 62 kΩ; IREF = 20 μA
33	STO	Sidetone reduction output output resistance approx.: 300 Ω, maximum load impedance: 10 kΩ.
34	V _M	Reference node for microphone-earphone and loudspeaker amplifier, supply for electret microphone (IM ≤ 700 μA)
35	MUTR	Three-state mute input 1. Normal operation 2. Mute of ear piece 3. Mute of RECIN signal Condition of earpiece mute is stored
36	RECO 2	Inverting output of receiving amplifier
37	STI S	Input for sidetone network (short loop) or for answering machine
38	STI L	Input for sidetone network (long loop)
39	RAC	Input of receiving amplifier for ac coupling in feedback path
40	RECO 1	Output of receiving amplifier
41	G _R	A resistor connected from this pin to GND sets the receiving amplification of the circuit; amplifier RA1 can be muted by applying VMP to GR
42	TTXA	Time constant of anti-clipping in transmit path
43	RECIN	Input of receiving path; input impedance is typically 80 kΩ
44	TXIN	Input of intermediate transmit stage, input resistance is typically 20 kΩ

Filters against electromagnetic interference (EMI) are located at following pins: MIC1, MIC2, RECIN, TXIN, STIS, STIL and RAC.

DC Line Interface and Supply-Voltage Generation

The DC line interface consists of an electronic inductance and a dual-port output stage which charges the capacitors at V_{MPS} and V_B . The value of the equivalent inductance is given by:

$$L = R_{SENSE} \times C_{IND} \times ((R_{DC} \times R_{30}) / (R_{DC} + R_{30}))$$

In order to improve the supply during worst-case operating conditions, two PNP current sources - I_{BOPT} and

I_{MPSOPT} - hand an extra amount of current to the supply voltages when the NPNs in parallel are unable to conduct current.

A flowchart for the control of the current sources (figure 3) shows how a priority for supply V_{MPS} is achieved.

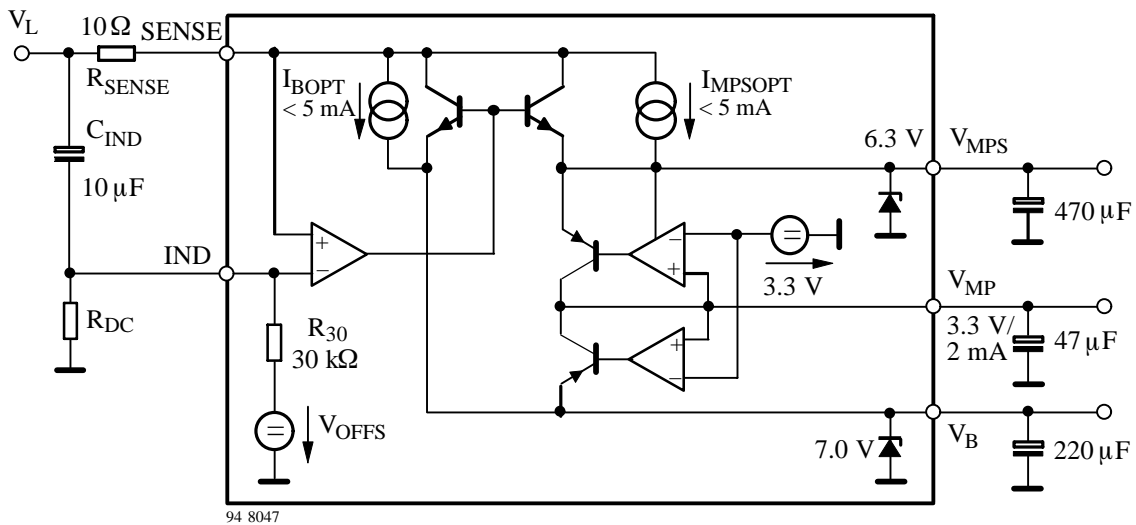

Figure 2. DC line interface with electronic inductance and generation of a regulated and an unregulated supply

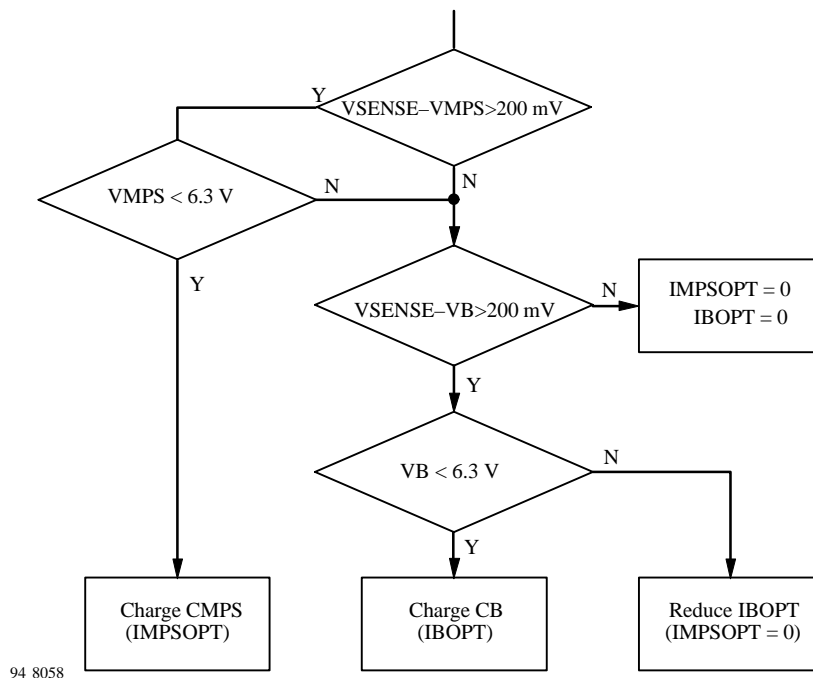

Figure 3. Supply capacitors CMPS and CB are charged with priority on CMPS

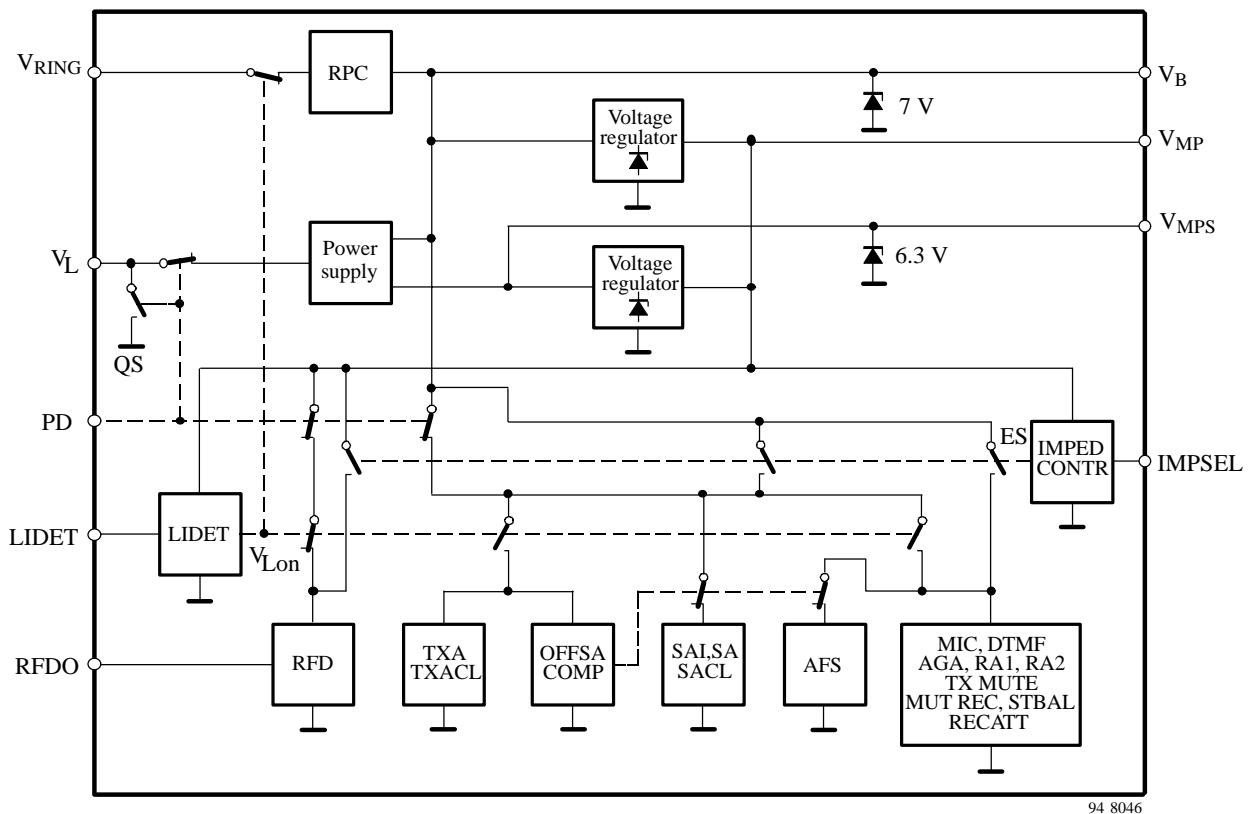

Figure 4. Supply of functional blocks is controlled by input voltages V_L , V_B , V_{RING} and by logic inputs PD and IMPSEL

The U4090B-P contains two identical series regulators which provide a supply voltage V_{MP} of 3.3 V suitable for a microprocessor. In speech mode, both regulators are active because V_{MPS} and V_B are charged simultaneously by the DC-line interface. Output current is 4 mA. The capacitor at V_{MPS} is used to provide the microcomputer with sufficient power during long-line interruptions. Thus, long flash pulses can be bridged or a LCD display can be turned on for more than 2 seconds after going on hook. When the system is in ringing mode, V_B is charged by the on-chip ringing power converter. In this mode only one regulator is used to supply V_{MP} with max. 2 mA.

Supply Structure of the Chip

As a major benefit the chip uses a very flexible system structure which allows simple realization of numerous applications such as:

- Group listening phone
- Hands-free phone
- Ringing with the built in speaker amplifier
- Answering machine with external supply

The special supply topology for the various functional blocks is illustrated in figure 4.

There are four major supply states:

1. Speech condition
 2. Power down (pulse dialing)
 3. Ringing
 4. External supply
1. In speech condition the system is supplied by the line current. If the LIDET-block detects a line voltage above the fixed threshold (1.9 V), the internal signal VLON is activated, thus switching off RFD and RPC and switching on all other blocks of the chip.

At line voltages below 1.9 V, the switches remain in their quiescent state as shown in the diagram.

OFFSACOMP disables the group listening feature (SAI, SA, SACL, AFS) below line currents of approximately 10 mA.

2. When the chip is in power-down mode (PD = high), e.g., during pulse dialing, the internal switch QS shorts the line and all amplifiers are switched off. In this

condition, LIDET, voltage regulators and IMPED CONTR are the only active blocks.

3. During ringing, the supply for the system is fed into V_B via the ringing power converter (RPC). The only functional amplifiers are in the speaker amplifier section (SAI, SA, SACL).
4. In an answering machine, the chip is powered by an external supply via pin V_B . This application allows the possibility to activate all amplifiers (except the transmit line interface TXA). Selecting IMPSEL = high impedance activates all switches at the ES line.

Acoustic Feedback Suppression

Acoustical feedback from the loudspeaker to the handset microphone may cause instability in the system. The U4090B-P offers a very efficient feedback suppression

circuit, which uses a modified voice switch topology. Figure 5 shows the basic system configuration.

Two attenuators (TX ATT and RX ATT) reduce the critical loop gain by introducing an externally adjustable amount of loss either in the transmit or in the receive path. The sliding control in block ATT CONTR determines, whether the TX or the RX signal has to be attenuated. The overall loop gain remains constant under all operating conditions.

Selection of the active channel is made by comparison of the logarithmically compressed TX- and RX- envelope curve.

The system configuration for group listening, which is realized in the U4090B-P, is illustrated in figure 7. TXA and SAI represent the two attenuators, the logarithmic envelope detectors are shown in a simplified way (operational amplifiers with two diodes).

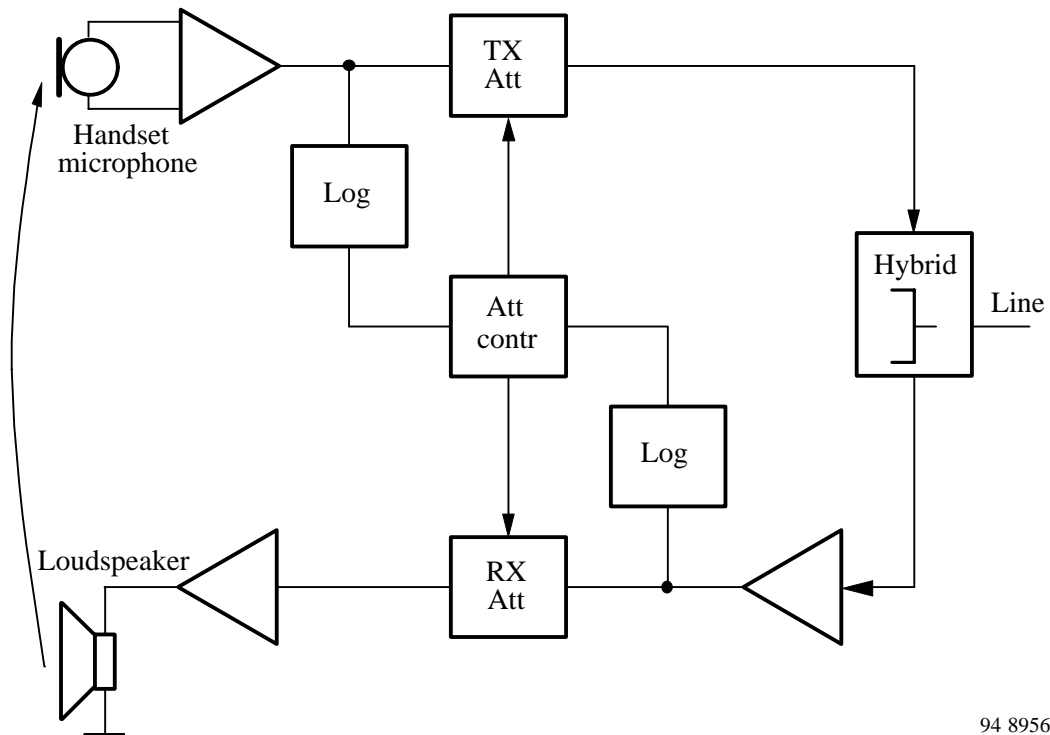

94 8956

Figure 5. Basic voice switch system

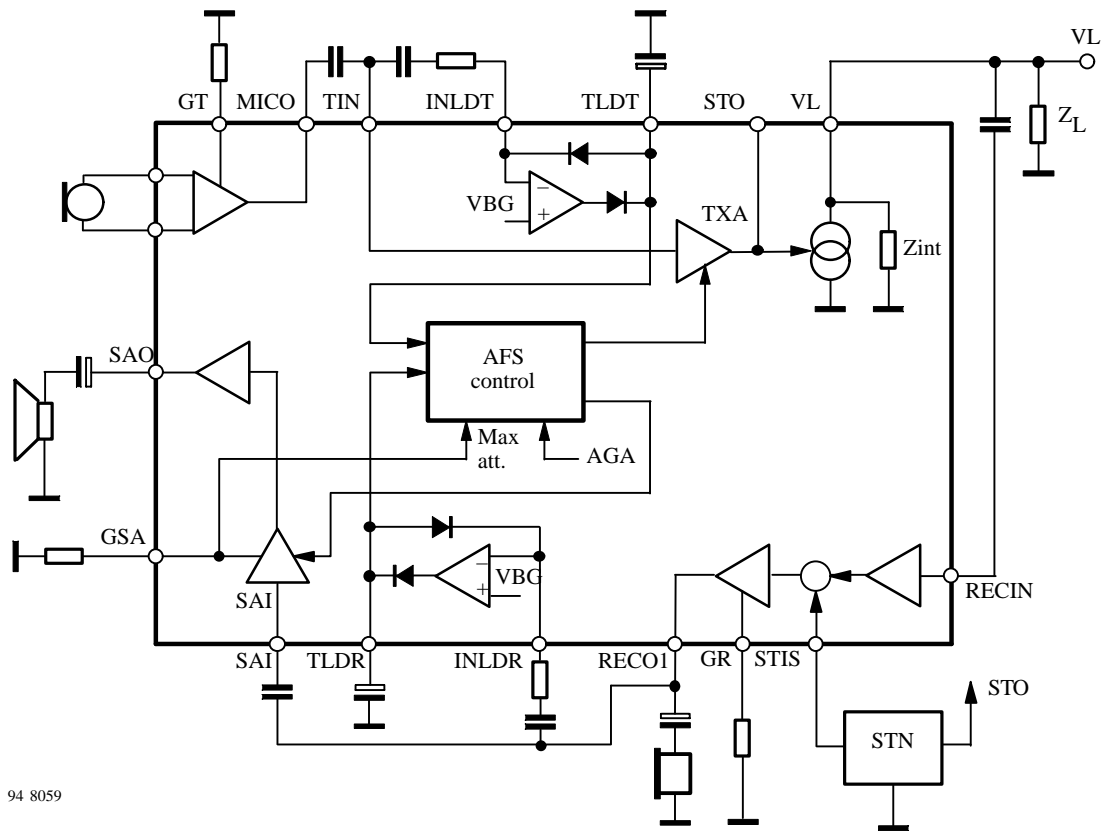

94 8059

Figure 6. Integration of acoustic feedback suppression circuit into the speech circuit environment

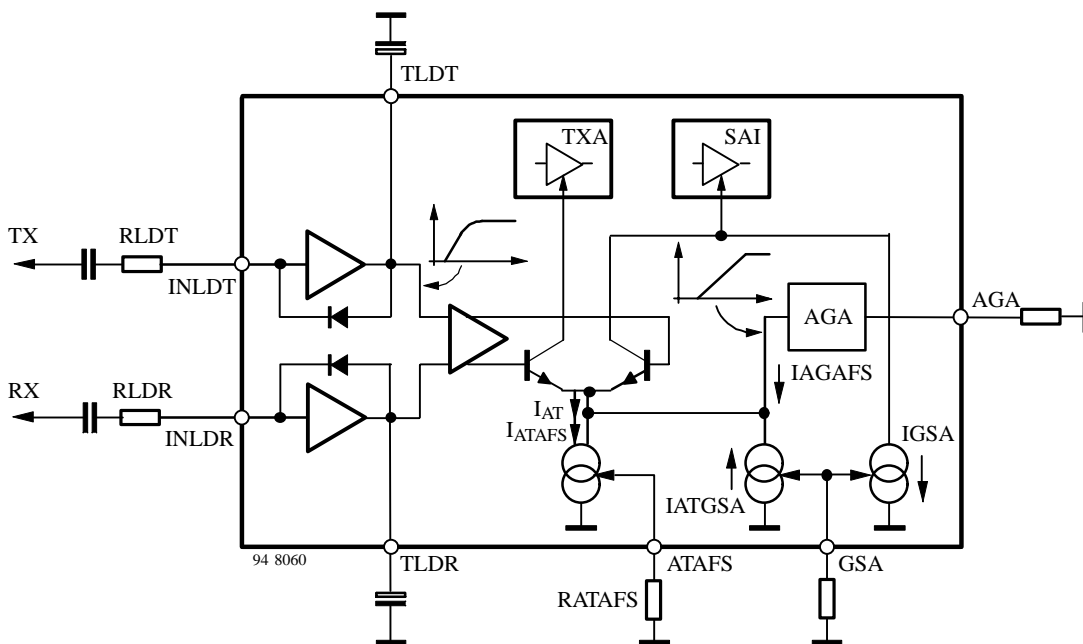

94 8060

Figure 7. Acoustic feedback suppression by alternative control of transmit- and speaker amplifier gain

A detailed diagram of the AFS (acoustic feedback suppression) is given in figure 7. Receive and Transmit signals are first processed by logarithmic rectifiers in order to produce the envelopes of the speech at TLDT and RLDT. After amplification, a decision is made by the differential pair which direction should be transmitted.

The attenuation of the controlled amplifiers TXA and SAI is determined by the emitter current I_{AT} which consists of three parts:

- I_{ATAS} sets maximum attenuation
- I_{ATGSA} decreases the attenuation when speaker amplifier gain is reduced
- I_{AGAFS} decreases the attenuation according to the loop gain reduction caused by the AGA-function

$$I_{AT} = I_{ATAFS} - I_{ATGSA} - I_{AGAFS}$$

$$\Delta G = I_{AT} \times 0.67 \text{ dB}/\mu\text{A}$$

Figure 8 illustrates the principle relationship between speaker amplifier gain (GSA) and attenuation of AFS (ATAFS). Both parameters can be adjusted independently, but the internal coupling between them has to be considered. Maximum usable value of GSA is 36 dB. The shape of the characteristic is moved in the x-direction by adjusting resistor RATAFS, thus changing ATAFS_m. The actual value of attenuation (ATAFS_a), however, can be determined by reading the value which belongs to the actual gain GSA_a. If the speaker amplifier gain is reduced, the attenuation of AFS is automatically reduced by the same amount in order to achieve a constant loop gain. Zero attenuation is set for speaker gains GSA ≤ GSA₀ = 36 dB - ATAFS_m.

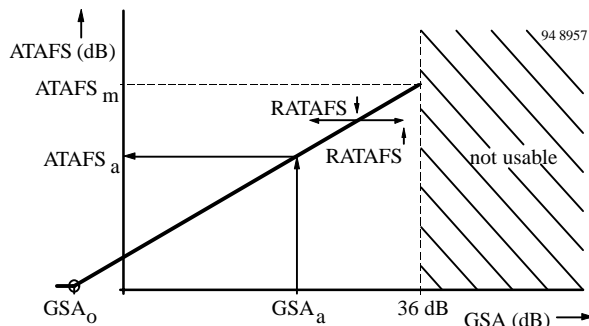

Figure 8. Reducing speaker amplifier gain results in an equal reduction of AFS attenuation

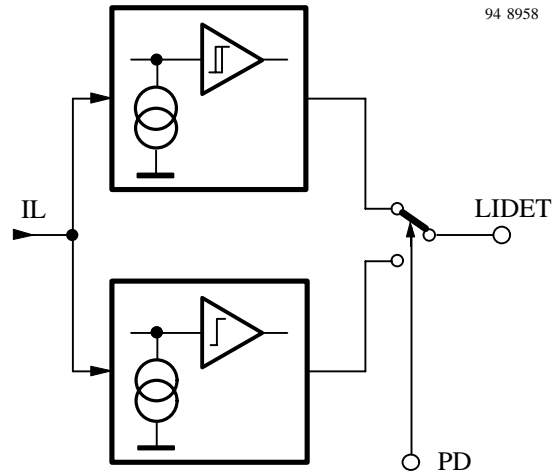

Figure 9. Line detection with two comparators for speech mode and pulse dialing

Line Detection (LIDET)

The line current supervision is active under all operating conditions of the U4090B-P. In speech mode (PD = inactive), the line-current comparator uses the same thresholds as the comparator for switching off the entire speaker amplifier. The basic behavior is illustrated in figure 10. Actual values of I_{LON}/I_{LOFF} vary slightly with the adjustment of the DC characteristics and the selection of the internal line impedance.

When Power Down is activated (during pulse dialing), the entire line current flows through the short-circuiting transistor QS (see figure 4). As long as I_L is above typ. 1.6 mA, output LIDET is low. This comparator does not use hysteresis.

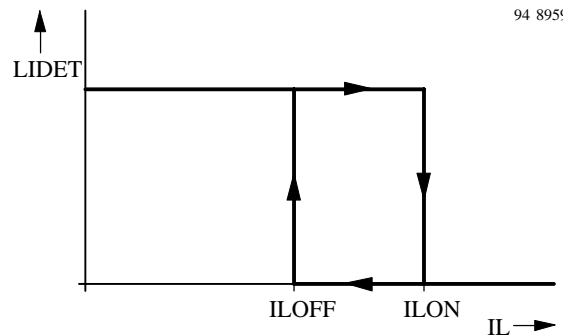
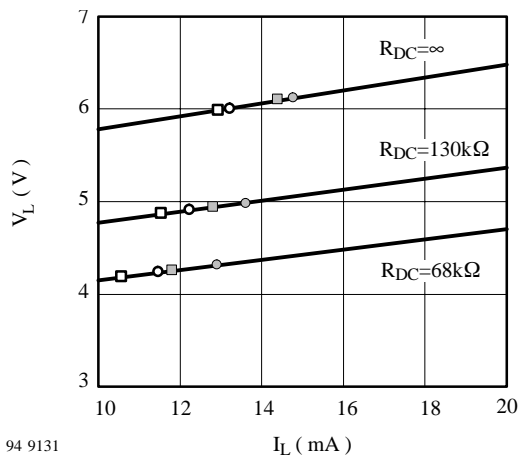

Figure 10. Line detection in speech mode with hysteresis

Ringing Power Converter (RPC)

The RPC transforms the input power at VRING (high voltage/ low current) into an equivalent output power at VB (low voltage/ high current) which is capable of driving the low-ohmic loudspeaker. Input impedance at VRING is fixed at 5 kΩ and the efficiency of the step-down converter is approx. 65%.



94 9131

- = ILON at line impedance = 600 Ω
- = ILOFF at line impedance = 600 Ω
- = ILON at line impedance = 900 Ω
- = ILOFF at line impedance = 900 Ω

Figure 11. Comparator thresholds depending on dc mask and line impedance

Ringing Frequency Detector (RFD)

The U4090B-P offers an output signal for the microcontroller, which is a digital representation of the double ringing frequency. It is generated by a current comparator with hysteresis. The input voltage VRING is transformed into a current via RTHA. The thresholds are 8 μA and 24 μA. RFDO and VRING are in phase. A second comparator with hysteresis is used to enable the output RFDO as long as the supply voltage for the microprocessor VMP is above 2.0 V.

Absolute Maximum Ratings

Parameters	Symbol	Value	Unit
Line current	IL	140	mA
DC line voltage	VL	12	V
Maximum input current Pin 17	IRING	15	mA
Junction temperature	Tj	125	°C
Ambient temperature	Tamb	-25 to +75	°C
Storage temperature	Tstg	-55 to +150	°C
Total power dissipation, Tamb = 60°C	Ptot	0.9	W

Thermal Resistance

Parameters	Symbol	Value	Unit
Junction ambient SSO44	RthJA	70	K/W

Electrical Characteristics

$f = 1 \text{ kHz}$, $0 \text{ dBm} = 775 \text{ mV}_{\text{rms}}$, $I_M = 0.3 \text{ mA}$, $I_{MP} = 2 \text{ mA}$, $RDC = 130 \text{ k}\Omega$, $T_{\text{amb}} = 25^\circ\text{C}$, $RGSA = 560 \text{ k}\Omega$, $Z_{\text{ear}} = 68 \text{ nF} + 100 \text{ }\Omega$, $Z_M = 68 \text{ nF}$, Pin 31 open, $V_{\text{IMPSEL}} = \text{GND}$, $V_{\text{MUTX}} = \text{GND}$, $V_{\text{MUTR}} = \text{GND}$, unless otherwise specified.

Parameters	Test Conditions / Pin	Symbol	Min.	Typ.	Max.	Unit	Figure
DC characteristics							
DC voltage drop over circuit	$I_L = 2 \text{ mA}$ $I_L = 14 \text{ mA}$ $I_L = 60 \text{ mA}$ $I_L = 100 \text{ mA}$	V_L	4.6	2.4 5.0 7.5 9.4	5.4 10.0	V	20
Transmission amplifier, $I_L = 14 \text{ mA}$, $V_{\text{MIC}} = 2 \text{ mV}$, $RGT = 27 \text{ k}\Omega$, unless otherwise specified							
Range of transmit gain		G_T	40	45	50	dB	21
Transmitting amplification	$RGT = 12 \text{ k}\Omega$ $RGT = 27 \text{ k}\Omega$	G_T	47 39.8	48	49 41.8	dB	21
Frequency response	$I_L \geq 14 \text{ mA}$, $f = 300 \text{ to } 3400 \text{ Hz}$	ΔG_T			± 0.5	dB	21
Gain change with current	Pin 31 open $I_L = 14 \text{ to } 100 \text{ mA}$	ΔG_T			± 0.5	dB	21
Gain deviation	$T_{\text{amb}} = -10 \text{ to } +60^\circ\text{C}$	ΔG_T			± 0.5	dB	21
CMRR of microphone amplifier		CMRR	60	80		dB	21
Input resistance of MIC amplifier	$RGT = 12 \text{ k}\Omega$ $RGT = 27 \text{ k}\Omega$	R_i	45	50 75	110	$\text{k}\Omega$	21
Distortion at line	$I_L > 14 \text{ mA}$ $V_L = 700 \text{ mV}_{\text{rms}}$	d_t			2	%	21
Maximum output voltage	$I_L > 19 \text{ mA}$, $d < 5\%$ $V_{\text{mic}} = 25 \text{ mV}$ $CTXA = 1 \text{ }\mu\text{F}$	$V_{L\text{max}}$	1.8	3	4.2	dBm	21
	IMPSEL = open $RGT = 12 \text{ k}\Omega$	V_{MICOmax}		-5.2		dBm	21
Noise at line psophometrically weighted	$I_L > 14 \text{ mA}$ $G_T = 48 \text{ dB}$	no		-80	-72	dBmp	21
Anti-clipping attack time release time	$CTXA = 1 \text{ }\mu\text{F}$ each 3 dB overdrive			0.5 9		ms	21
Gain at low operating current	$I_L = 10 \text{ mA}$ $I_{MP} = 1 \text{ mA}$ $RDC = 68 \text{ k}\Omega$ $V_{\text{mic}} = 1 \text{ mV}$ $I_M = 300 \text{ }\mu\text{A}$	G_T	40		42.5	dB	21
Distortion at low operating current	$I_L = 10 \text{ mA}$ $I_M = 300 \text{ }\mu\text{A}$ $I_{MP} = 1 \text{ mA}$ $RDC = 68 \text{ k}\Omega$ $V_{\text{mic}} = 10 \text{ mV}$	d_t			5	%	21
Line loss compensation	$I_L = 100 \text{ mA}$, $RAGA = 20 \text{ k}\Omega$	ΔG_{TI}	-6.4	-5.8	-5.2	dB	21
Mute suppression a) MIC muted (microphone preamplifier b) TXA muted (second stage)	$I_L \geq 14 \text{ mA}$ Mutx = open	G_{TM}	60	80		dB	21
	IMPSEL = open	G_{TTX}	60			dB	21

U4090B-P



Electrical Characteristics (continued)

$f = 1 \text{ kHz}$, $0 \text{ dBm} = 775 \text{ mV}_{\text{rms}}$, $I_M = 0.3 \text{ mA}$, $I_{MP} = 2 \text{ mA}$, $RDC = 130 \text{ k}\Omega$, $T_{\text{amb}} = 25^\circ\text{C}$, $RGSA = 560 \text{ k}\Omega$, $Z_{\text{ear}} = 68 \text{ nF} + 100 \text{ }\Omega$, $Z_M = 68 \text{ nF}$, Pin 31 open, $V_{\text{IMPSEL}} = \text{GND}$, $V_{\text{MUTX}} = \text{GND}$, $V_{\text{MUTR}} = \text{GND}$, unless otherwise specified.

Parameters	Test Conditions / Pin	Symbol	Min.	Typ.	Max.	Unit	Figure
Receiving amplifier, $I_L = 14 \text{ mA}$, $RGR = 62 \text{ k}$, unless otherwise specified, $V_{\text{GEN}} = 300 \text{ mV}$							
Adjustment range of receiving gain	$I_L \geq 14 \text{ mA}$, single ended differential MUTR = GND	G_R	-8 -2		+2 +8	dB	22
Receiving amplification	$RGR = 62 \text{ k}\Omega$ differential $RGR = 22 \text{ k}\Omega$ differential	G_R	-1.75	-1 7.5	-0.25	dB	22
Amplification of DTMF signal from DTMF IN to RECO 1, 2	$I_L \geq 14 \text{ mA}$ $V_{\text{MUTX}} = V_{\text{MP}}$	G_{RM}	7	10	13	dB	22
Frequency response	$I_L > 14 \text{ mA}$, $f = 300 \text{ to } 3400 \text{ Hz}$	ΔG_{RF}			± 0.5	dB	22
Gain change with current	$I_L = 14 \text{ to } 100 \text{ mA}$	ΔG_R			± 0.5	dB	22
Gain deviation	$T_{\text{amb}} = -10 \text{ to } +60^\circ\text{C}$	ΔG_R			± 0.5	dB	22
Ear-protection differential	$I_L \geq 14 \text{ mA}$ $V_{\text{GEN}} = 11 \text{ V}_{\text{rms}}$	EP			2.2	V_{rms}	22
MUTE suppression a) RECAT1 b) RA2 c) DTMF operation	$I_L \geq 14 \text{ mA}$ MUTR = open $V_{\text{MUTR}} = V_{\text{MP}}$ $V_{\text{MUTX}} = V_{\text{MP}}$	ΔG_R	60			dB	22
Output voltage $d \leq 2\%$ differential	$I_L = 14 \text{ mA}$ $Z_{\text{ear}} = 68 \text{ nF} + 100 \text{ }\Omega$		0.775			V_{rms}	22
Maximum output current $d \leq 2\%$	$Z_{\text{ear}} = 100 \text{ }\Omega$		4			mA (peak)	22
Receiving noise psophometrically weighted	$Z_{\text{ear}} = 68 \text{ nF} + 100 \text{ }\Omega$ $I_L \geq 14 \text{ mA}$	ni		-80	-77	dBmp	22
Output resistance	each output against GND	R_o			10	Ω	22
Line loss compensation	$RAGA = 20 \text{ k}\Omega$, $I_L = 100 \text{ mA}$	ΔG_{RI}	-7.0	-6.0	-5.0	dB	22
Gain at low operating current	$I_L = 10 \text{ mA}$ $I_{\text{MP}} = 1 \text{ mA}$ $I_M = 300 \text{ }\mu\text{A}$ $V_{\text{GEN}} = 560 \text{ mV}$ $RDC = 68 \text{ k}\Omega$	G_R	-2	-1	0	dB	22
AC impedance	$V_{\text{IMPSEL}} = \text{GND}$ $V_{\text{IMPSEL}} = V_{\text{MP}}$	Z_{imp} Z_{imp}	570 840	600 900	640 960	Ω Ω	22
Distortion at low operating current	$I_L = 10 \text{ mA}$ $I_{\text{MP}} = 1 \text{ mA}$ $V_{\text{GEN}} = 560 \text{ mV}$ $RDC = 68 \text{ k}\Omega$	dR			5	%	22

Electrical Characteristics (continued)

$f = 1 \text{ kHz}$, $0 \text{ dBm} = 775 \text{ mV}_{\text{rms}}$, $I_M = 0.3 \text{ mA}$, $I_{MP} = 2 \text{ mA}$, $RDC = 130 \text{ k}\Omega$, $T_{\text{amb}} = 25^\circ\text{C}$, $RGSA = 560 \text{ k}\Omega$, $Z_{\text{ear}} = 68 \text{ nF} + 100 \text{ }\Omega$, $Z_M = 68 \text{ nF}$, Pin 31 open, $V_{\text{IMPSEL}} = \text{GND}$, $V_{\text{MUTX}} = \text{GND}$, $V_{\text{MUTR}} = \text{GND}$, unless otherwise specified.

Parameters	Test Conditions / Pin	Symbol	Min.	Typ.	Max.	Unit	Figure
Speaker amplifier							
Minimum line current for operation	No ac signal	$I_{L\text{min}}$			15	mA	23
Input resistance	Pin 24		14		22	k Ω	23
Gain from SAI to SAO	$V_{\text{SAI}} = 3 \text{ mV}$, $I_L = 15 \text{ mA}$, $RGSA = 560 \text{ k}\Omega$ $RGSA = 20 \text{ k}\Omega$	G_{SA}	35.5	36.5 - 3	37.5	dB	23
Output power	Load resistance $R_L = 50 \text{ }\Omega$, $d < 5\%$ $V_{\text{SAI}} = 20 \text{ mV}$ $I_L = 15 \text{ mA}$ $I_L = 20 \text{ mA}$	P_{SA} P_{SA}	3	7 20		mW	23
Output noise (Input SAI open) psophometrically weighted	$I_L > 15 \text{ mA}$	n_{SA}			200	$\mu\text{V}_{\text{psoph}}$	23
Gain deviation	$I_L = 15 \text{ mA}$ $T_{\text{amb}} = -10 \text{ to } +60^\circ\text{C}$	ΔG_{SA}			± 1	dB	23
Mute suppression	$I_L = 15 \text{ mA}$, $V_L = 0 \text{ dBm}$, $V_{\text{SAI}} = 4 \text{ mV}$ Pin 23 open	V_{SAO}			-60	dBm	23
Gain change with current	$I_L = 15 \text{ to } 100 \text{ mA}$	ΔG_{SA}			± 1	dB	23
Resistor for turning off speaker amplifier	$I_L = 15 \text{ to } 100 \text{ mA}$	R_{GSA}	0.8	1.3	2	M Ω	23
Gain change with frequency	$I_L = 15 \text{ mA}$ $f = 300 \text{ to } 3400 \text{ Hz}$	ΔG_{SA}			± 0.5	dB	23
Attack time of anti-clipping	20 dB over drive	tr		5		ms	23
Release time of anti-clipping		tf		80		ms	23
DTMF amplifier Test conditions: $I_{MP} = 2 \text{ mA}$, $I_M = 0.3 \text{ mA}$, $V_{\text{MUTX}} = \text{VMP}$							
Adjustment range of DTMF gain	$I_L = 15 \text{ mA}$ Mute active	G_D	40		50	dB	24
DTMF amplification	$I_L = 15 \text{ mA}$, $V_{\text{DTMF}} = 8 \text{ mV}$ Mute active: $\text{MUTX} = \text{VMP}$	G_D	40.7	41.7	42.7	dB	24
Gain deviation	$I_L = 15 \text{ mA}$ $T_{\text{amb}} = -10 \text{ to } +60 \text{ }^\circ\text{C}$	G_D			± 0.5	dB	24
Input resistance	$R_{\text{GT}} = 27 \text{ k}\Omega$, $R_{\text{GT}} = 15 \text{ k}\Omega$	R_i	60 26	180 70	300 130	k Ω	24
Distortion of DTMF signal	$I_L \geq 15 \text{ mA}$ $V_L = 0 \text{ dBm}$	d_D			2	%	24
Gain deviation with current	$I_L = 15 \text{ to } 100 \text{ mA}$	ΔG_D			± 0.5	dB	24

Electrical Characteristics (continued)

$f = 1 \text{ kHz}$, $0 \text{ dBm} = 775 \text{ mV}_{\text{rms}}$, $I_M = 0.3 \text{ mA}$, $I_{MP} = 2 \text{ mA}$, $RDC = 130 \text{ k}\Omega$, $T_{\text{amb}} = 25^\circ\text{C}$, $RGSA = 560 \text{ k}\Omega$, $Z_{\text{ear}} = 68 \text{ nF} + 100 \text{ }\Omega$, $Z_M = 68 \text{ nF}$, Pin 31 open, $V_{\text{IMPSEL}} = \text{GND}$, $V_{\text{MUTX}} = \text{GND}$, $V_{\text{MUTR}} = \text{GND}$, unless otherwise specified.

Parameters	Test Conditions / Pin	Symbol	Min.	Typ.	Max.	Unit	Figure
AFS acoustic feedback suppression							
Adjustment range of attenuation	$I_L \geq 15 \text{ mA}$		0		50	dB	23
Attenuation of transmit gain	$I_L \geq 15 \text{ mA}$, $I_{\text{INLDT}} = 0 \text{ }\mu\text{A}$ $R_{\text{ATAFS}} = 30 \text{ k}\Omega$ $I_{\text{INLDR}} = 10 \text{ }\mu\text{A}$	ΔG_T		45		dB	23
Attenuation of speaker amplifier	$I_L \geq 15 \text{ mA}$ $I_{\text{INLDP}} = 0 \text{ }\mu\text{A}$ $R_{\text{ATAFS}} = 30 \text{ k}\Omega$ $I_{\text{INLDR}} = 10 \text{ }\mu\text{A}$	ΔG_{SA}		50		dB	23
AFS disable	$I_L \geq 15 \text{ mA}$	V_{ATAFS}	1.5			V	23
Supply voltages, $V_{\text{mic}} = 25 \text{ mV}$, $T_{\text{amb}} = -10 \text{ to} +60^\circ\text{C}$							
V_{MP}	$I_L = 14 \text{ mA}$, $RDC = 68 \text{ k}\Omega$ $I_{MP} = 2 \text{ mA}$	V_{MP}	3.1	3.3	3.5	V	20
V_{MPS}	$I_L = 100 \text{ mA}$ $RDC = \text{inf.}$, $I_{MP} = 0 \text{ mA}$	V_{MPS}			6.7	V	20
V_M	$I_L \geq 14 \text{ mA}$, $I_M = 700 \text{ }\mu\text{A}$ $RDC = 130 \text{ k}\Omega$	V_M	1.3		3.3	V	20
V_B	$I_B = +20 \text{ mA}$, $I_L = 0 \text{ mA}$	V_B		7	7.6	V	20
Ring power converter, $I_{MP} = 1 \text{ mA}$, $I_M = 0$							
Maximum output power	$V_{\text{RING}} = 20.6 \text{ V}$	P_{SA}		20		mW	25
Threshold of ring frequency detector	RFDO: low to high	V_{RINGON}		17.5		V	25
	$V_{\text{HYST}} = V_{\text{RINGON}} - \text{RINGOFF}$	V_{HYST}		11.0			
Input impedance	$V_{\text{RING}} = 30 \text{ V}$	R_{RING}	4	5	6	$\text{k}\Omega$	25
Input impedance in speech mode	$f = 300 \text{ Hz to } 3400 \text{ Hz}$ $I_L > 15 \text{ mA}$, $V_{\text{RING}} = 20\text{V} + 1.5V_{\text{rms}}$	R_{RINGSP}	150			$\text{k}\Omega$	25
Logic level of frequency detector	$V_{\text{RING}} = 0 \text{ V}$	V_{RFDO}		0		V	25
	$V_B = 4 \text{ V}$ $V_{\text{RING}} = 25 \text{ V}$			V_{MP}			
Ring detector enable	$V_{\text{RING}} = 25 \text{ V}$, RFDO high	V_{MPON}	1.8	2.0	2.2	V	25
Zener diode voltage	$I_{\text{RING}} = 25 \text{ mA}$	V_{RINGmax}	30.8		33.3	V	25

Electrical Characteristics (continued)

$f = 1 \text{ kHz}$, $0 \text{ dBm} = 775 \text{ mV}_{\text{rms}}$, $I_M = 0.3 \text{ mA}$, $I_{MP} = 2 \text{ mA}$, $RDC = 130 \text{ k}\Omega$, $T_{\text{amb}} = 25^\circ\text{C}$, $RGSA = 560 \text{ k}\Omega$, $Z_{\text{ear}} = 68 \text{ nF} + 100 \text{ }\Omega$, $Z_M = 68 \text{ nF}$, Pin 31 open, $V_{\text{IMPSEL}} = \text{GND}$, $V_{\text{MUTX}} = \text{GND}$, $V_{\text{MUTR}} = \text{GND}$, unless otherwise specified.

Parameters	Test Conditions / Pin	Symbol	Min.	Typ.	Max.	Unit	Figure
MUTR Input							
MUTR input current	$V_{\text{MUTR}} = \text{GND}$ $I_L > 14 \text{ mA}$ $V_{\text{MUTR}} = V_{\text{MP}}$	I_{MUTE}		-20 +10	-30	μA	26
MUTR input voltage	Mute low; $I_L > 14 \text{ mA}$	V_{MUTE}			0.3	V	26
	Mute high; $I_L > 14 \text{ mA}$	V_{MUTE}	$V_{\text{MP}}-0.3$ V			V	26
PD Input							
PD input current	PD active, $I_L > 14 \text{ mA}$ $V_{\text{PD}} = V_{\text{MP}}$	I_{pd}		9		μA	26
Input voltage	PD = active PD = inactive	V_{pd} V_{pd}	2		0.3	V	26
Voltage drop at V_L	$I_L = 14 \text{ mA}$, PD = active	V_L		1.5		V	26
	$I_L = 100 \text{ mA}$, PD = active	V_L		1.9			
Input characteristics of IMPSEL							
Input current	$I_L \geq 14 \text{ mA}$ $V_{\text{IMPSEL}} = V_{\text{MP}}$ $V_{\text{IMPSEL}} = \text{GND}$	I_{IMPSEL} I_{IMPSEL}		18 -18		μA μA	26
Input voltage	Input high	V_{IMPSEL}	$V_{\text{MP}}-0.3$ V			V	26
	Input low	V_{IMPSEL}			0.3	V	26
MUTX input							
Input current	$V_{\text{MUTX}} = V_{\text{MP}}$ $V_{\text{MUTX}} = \text{GND}$	I_{MUTX} I_{MUTX}		20 -20	30 -30	μA μA	26
Input voltage	Input high	V_{MUTX}	$V_{\text{MP}}-0.3$ V			V	26
	Input low	V_{MUTX}			0.3	V	26
Line detection							
Line current for LIDET active	PD = inactive	ILON		12.6		mA	20
Line current for LIDET inactive	PD = inactive	ILOFF		11.0		mA	20
Current threshold during power down	$V_B = 5 \text{ V}$, PD = active	ILONPD	0.8	1.6	2.4	mA	20

U4090B-P - Control

IMPSEL		MODE
0	Line-impedance = 600 Ω TXA = on ES = off	Speech
0 to Z	Line-impedance = 600 Ω TXA = off ES = on	Transmit-mute
1 to Z	Line-impedance = 900 Ω TXA = off ES = on	Transmit-mute
1	Line-impedance = 900 Ω TXA = on ES = off	Speech

MUTR		MODE
0	RA2 = on RECATT = on STIS + STIL = on	Speech
0 to Z	RA2 = on RECATT = off STIS = on, STIL = off	For answering machine
1 to Z	RA2 = off RECATT = off STIS = on, STIL = off AGA off for STIS	For answering machine
1	RA2 = off RECATT = on STIS + STIL = on	Speech + ear-peace mute

MUTX		MODE
0	MIC 1/2 transmit enabled receive enable AFS = on AGA = on TXACL = on	Speech
Z	DTMF transmit enabled receive enable AFS = on AGA = on TXACL = on	For answering machine
1	DTMF transmit enabled DTMF to receive enable AFS = off AGA = off TXACL = off	DTMF dialling

Logic-level

0 = < (0.3 V)
 Z = > (1 V) < (VMP - 1 V) or (open input)
 1 = > (VMP - 0.3 V)

RECATT = Receive attenuation
 STIS, STIL = Inputs of sidetone balancing amplifiers
 ES = External supply
 AFS = Acoustic feedback suppression control
 AGA = Automatic gain adjustment
 RA2 = Inverting receive amplifier
 TXACL = Transmit anti-clipping control

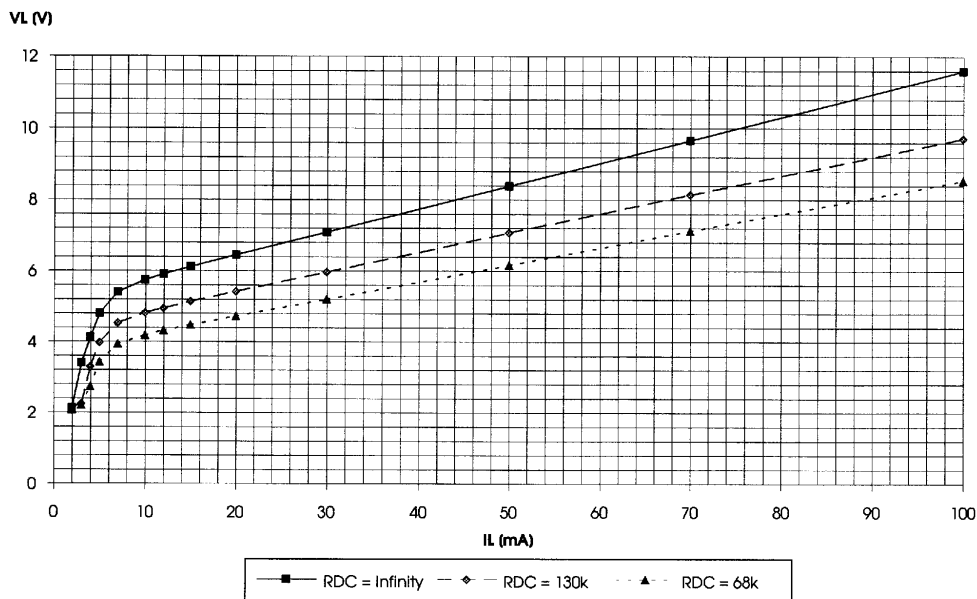

94 8856

Figure 12. Typical DC characteristic

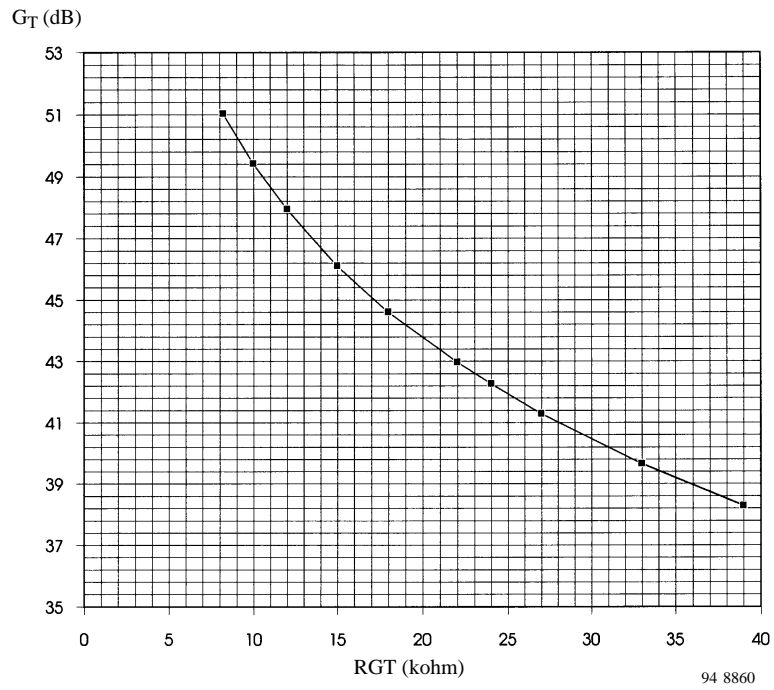

Figure 13. Typical adjustment range of transmit gain

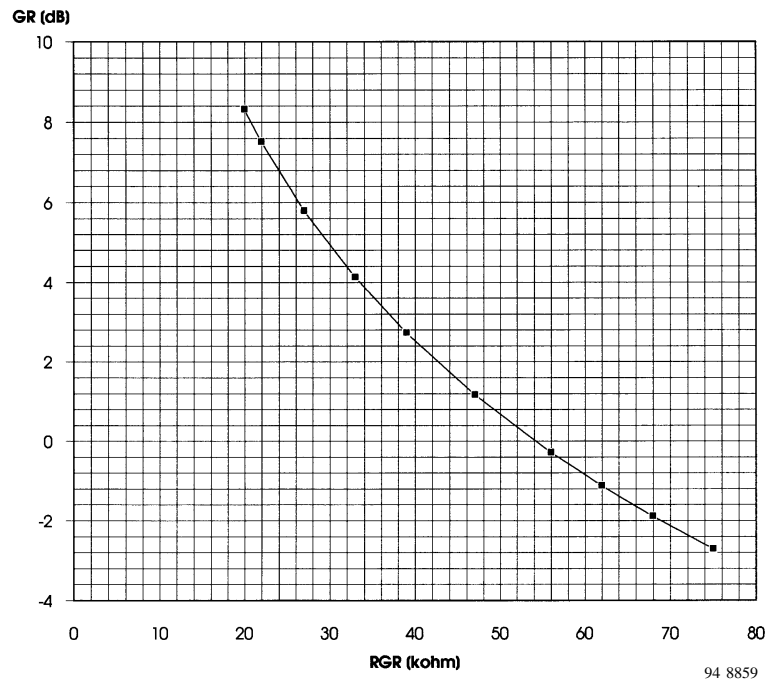

Figure 14. Typical adjustment range of receive gain (differential output)

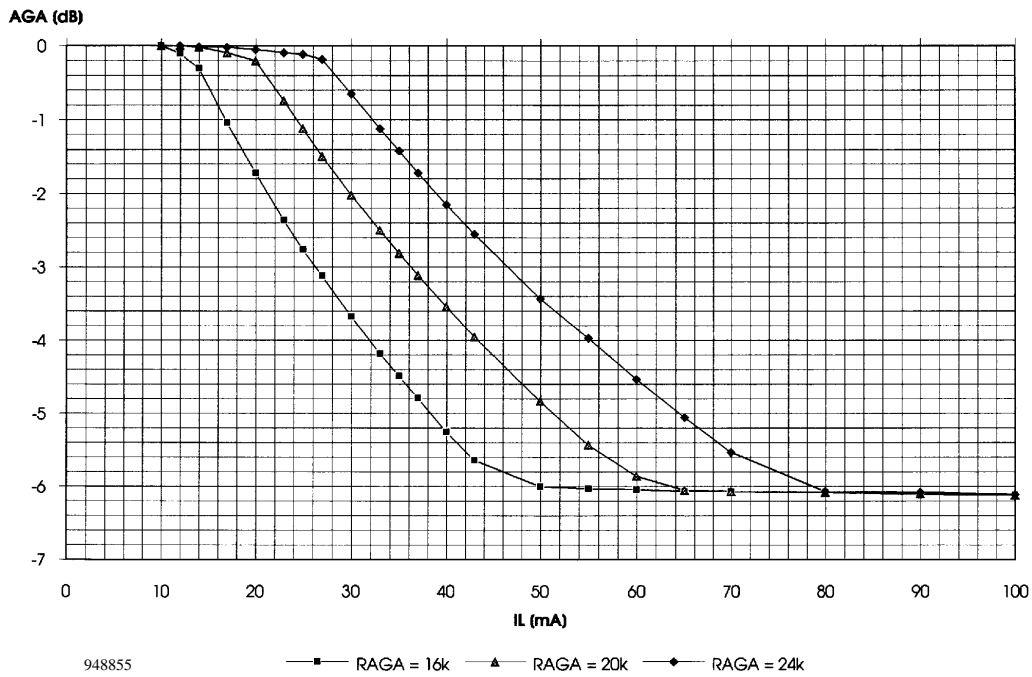

Figure 15. Typical AGA characteristic

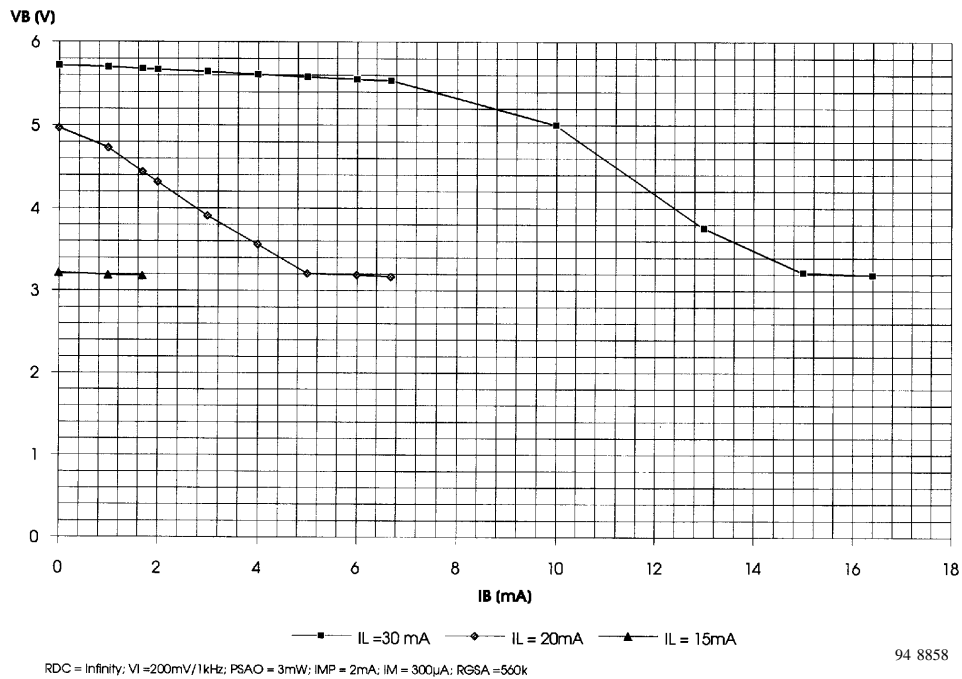

Figure 16. Typical load characteristic of V_B for a maximum (RDC = infinity) DC-characteristic and 3-mW loudspeaker output

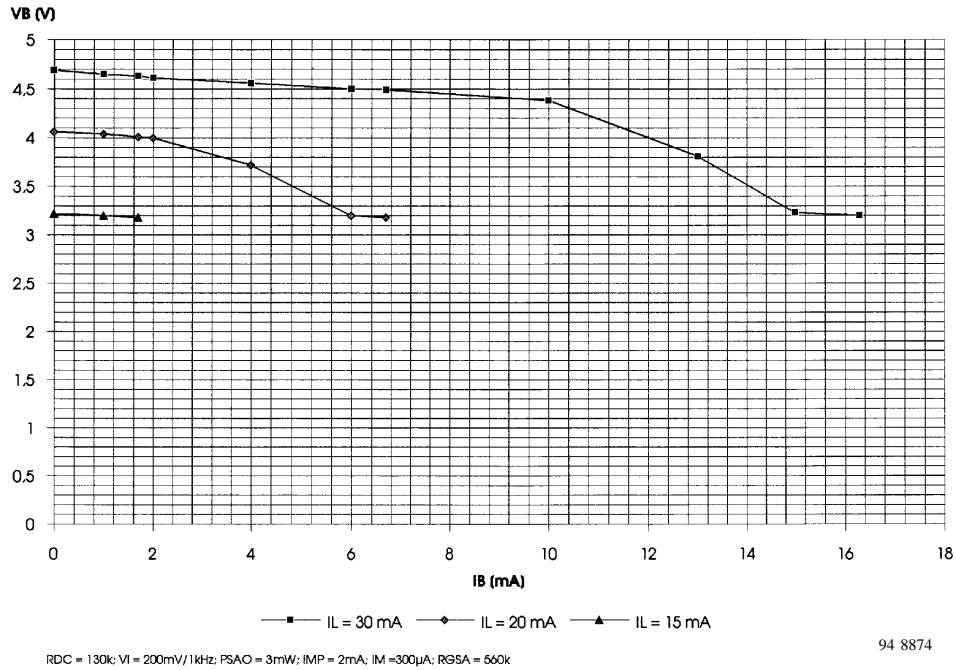

Figure 17. Typical load characteristic of V_B for a medium DC-characteristic ($RDC = 130\text{ k}\Omega$) and 3-mW loudspeaker output

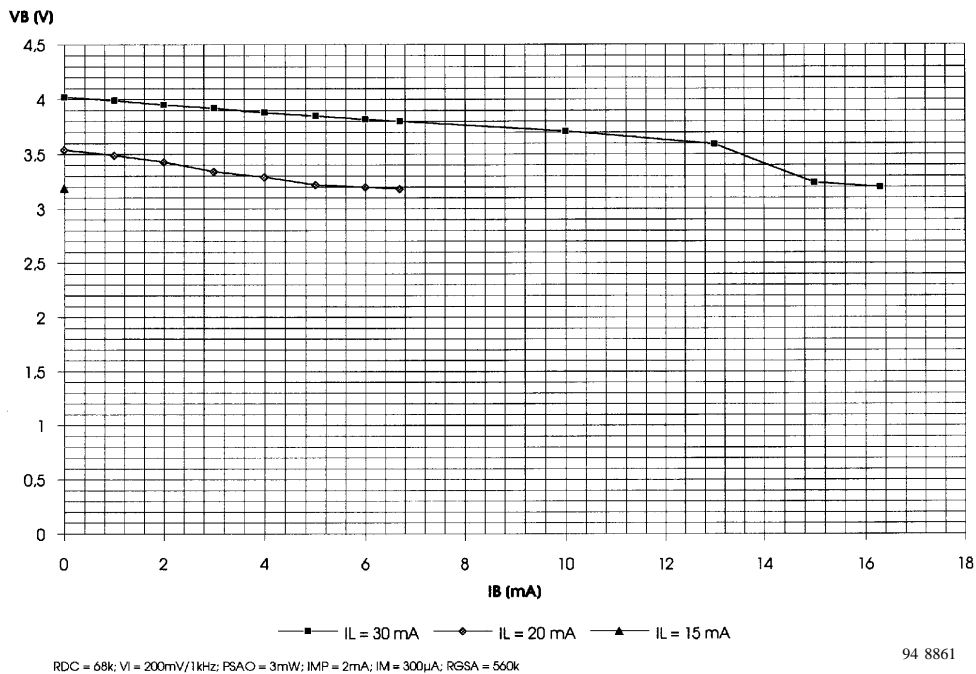
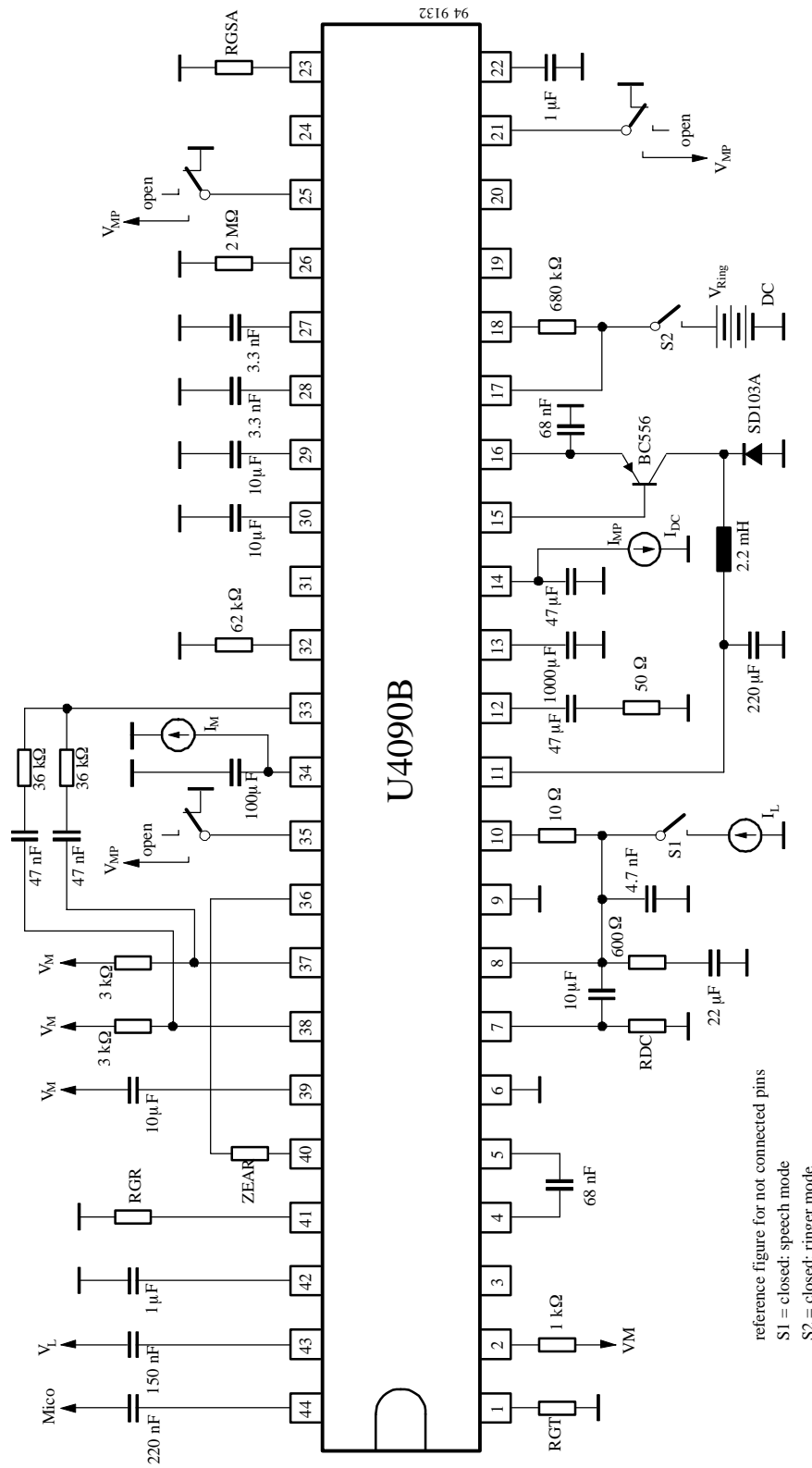
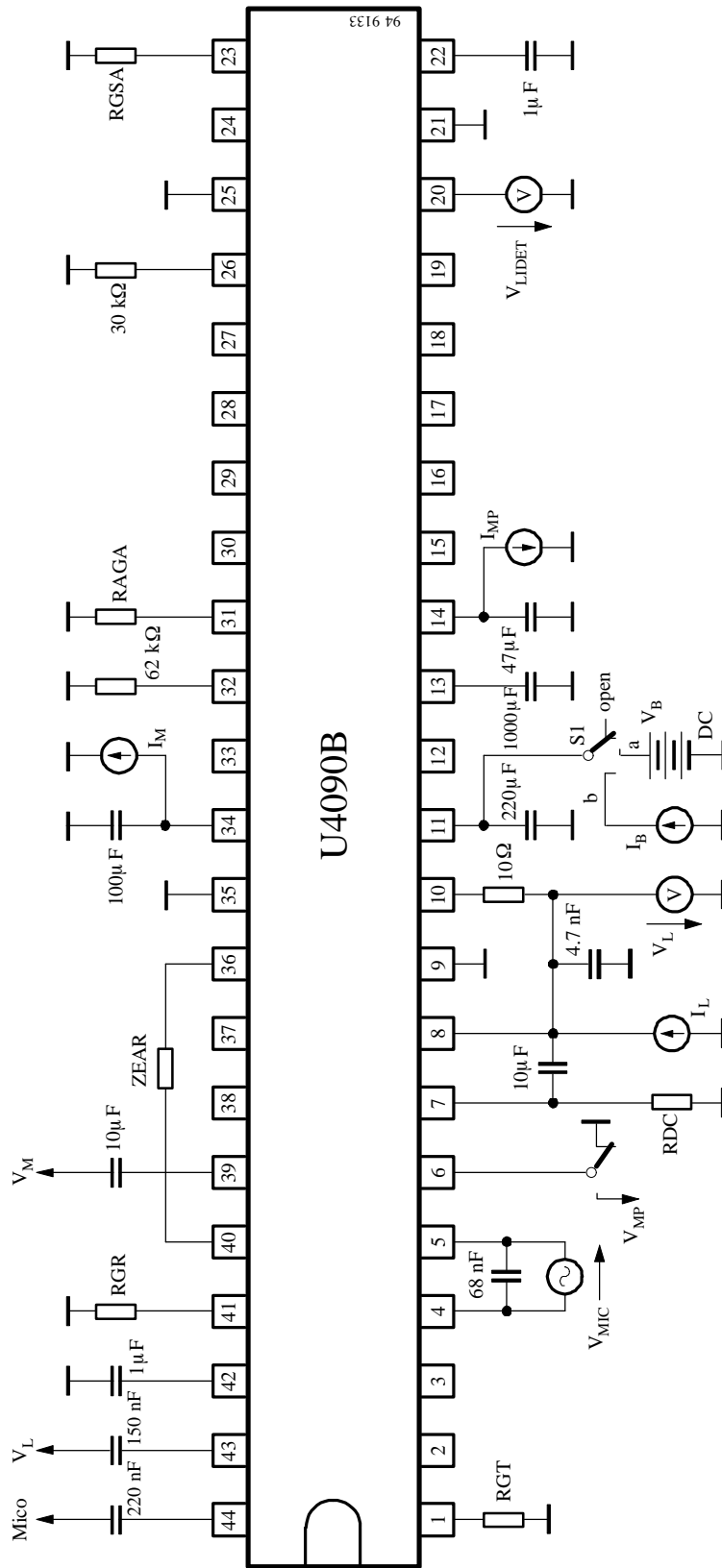

Figure 18. Typical load characteristic of V_B for a minimum DC-characteristic ($RDC = 68\text{ k}\Omega$) and 3-mW loudspeaker output



reference figure for not connected pins
 S1 = closed: speech mode
 S2 = closed: ringer mode

Figure 19. Basic test circuit



Line detection: S1a
VB (external supply): S1b
open pins should be connected as shown in figure 25

Figure 20. Test circuit for DC characteristics and line detection

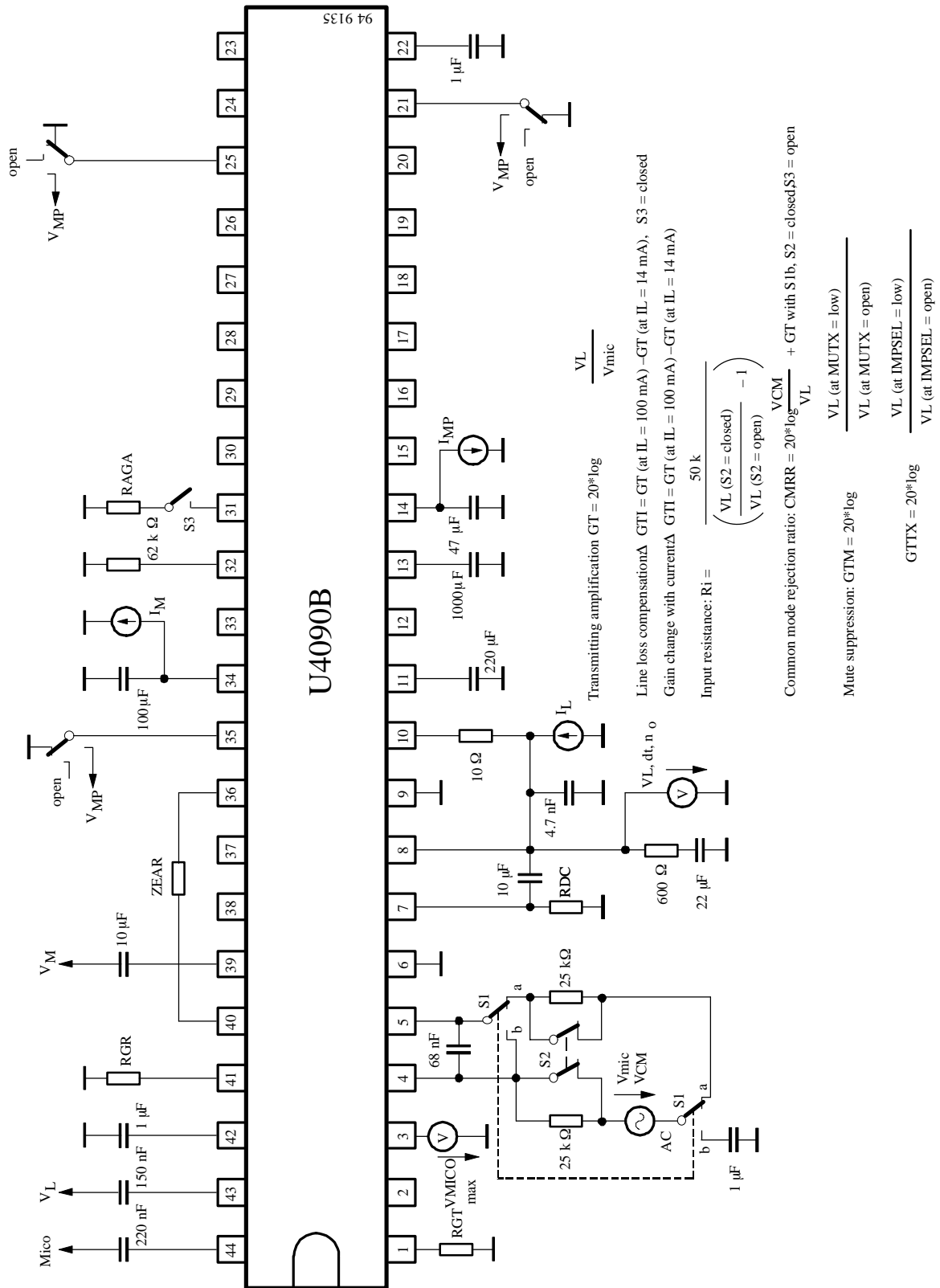

Figure 21. Test circuit for transmission amplifier

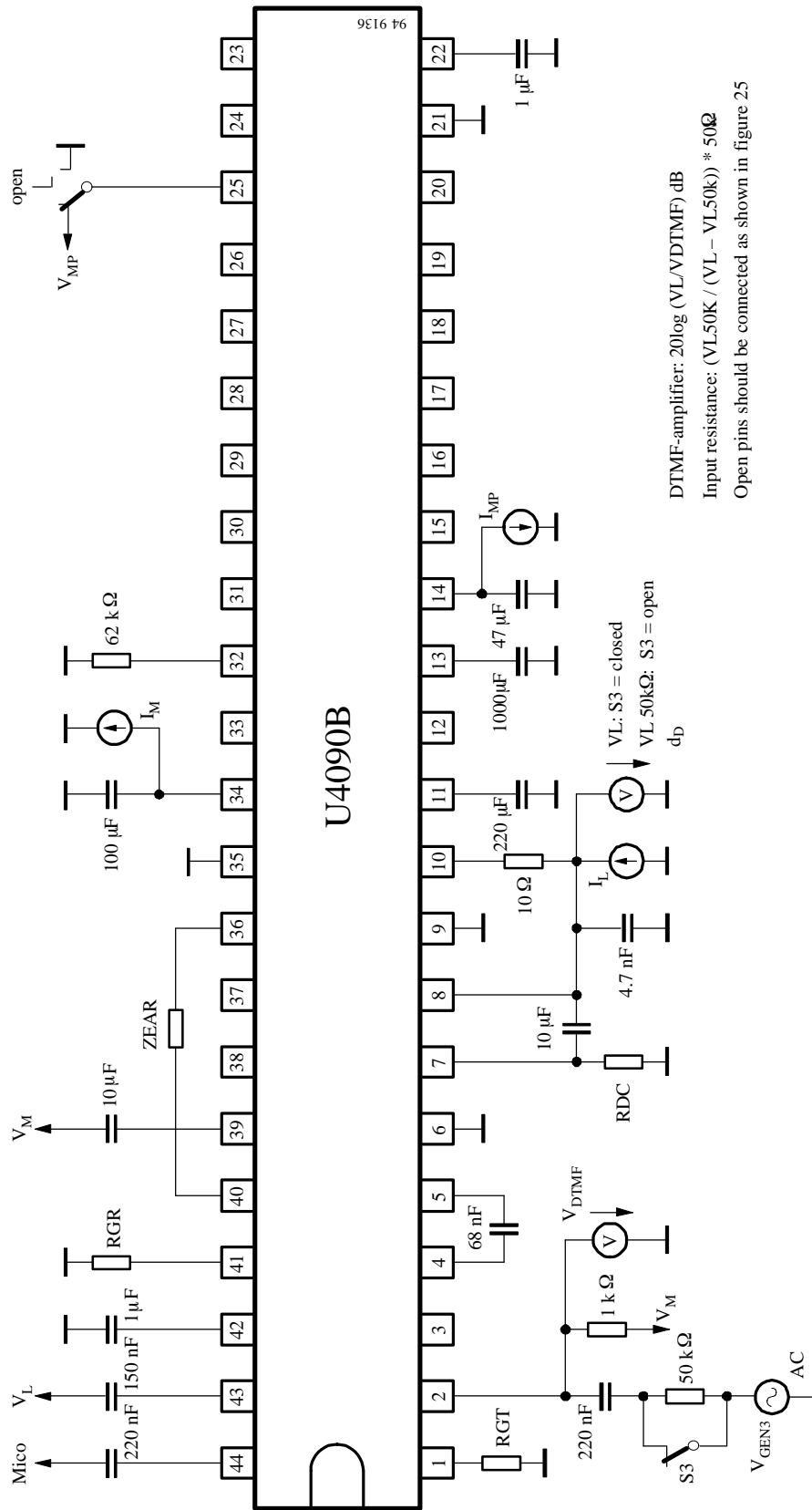

Figure 24. Test circuit for DTMF amplifier

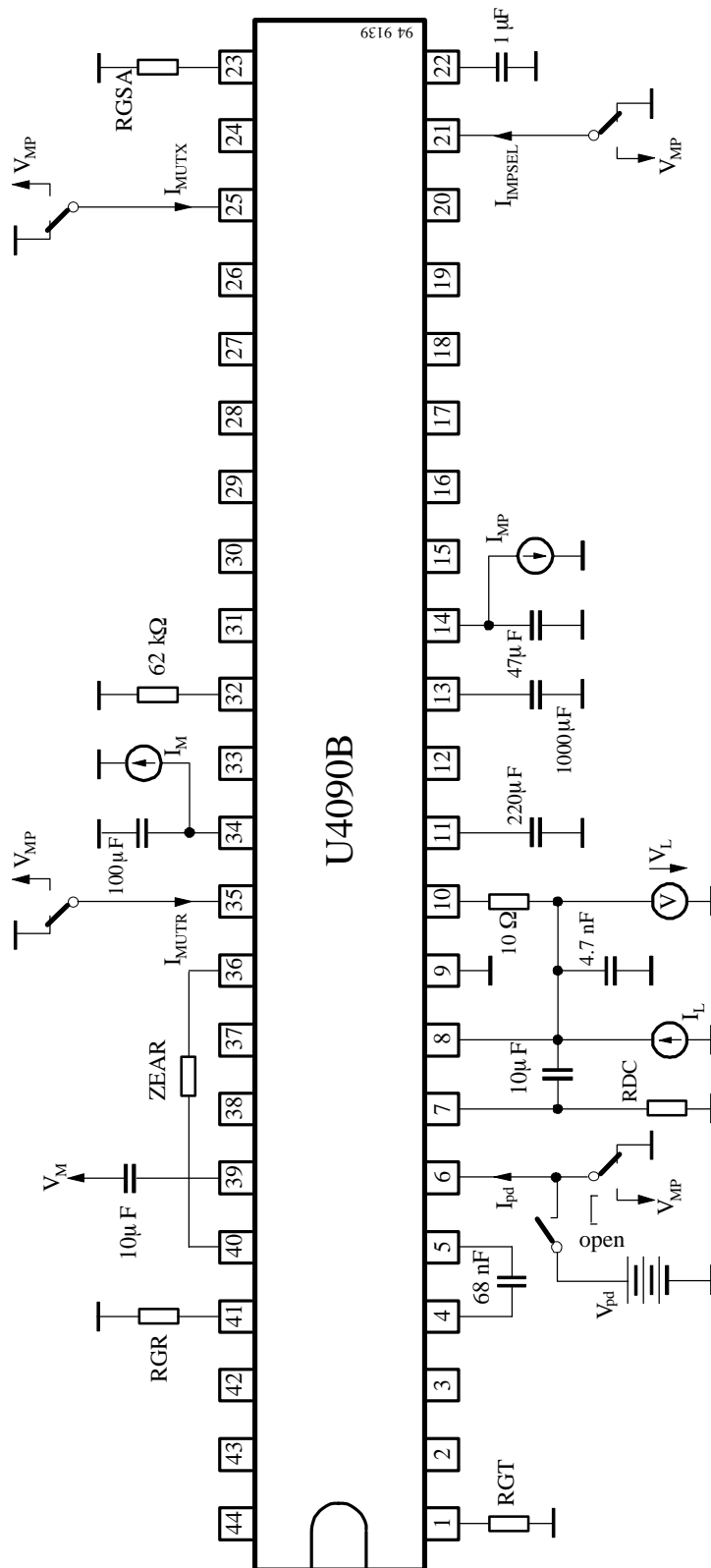

Figure 26. Test circuit for input characteristics of I/O-ports

Open pins should be connected as shown in figure 25

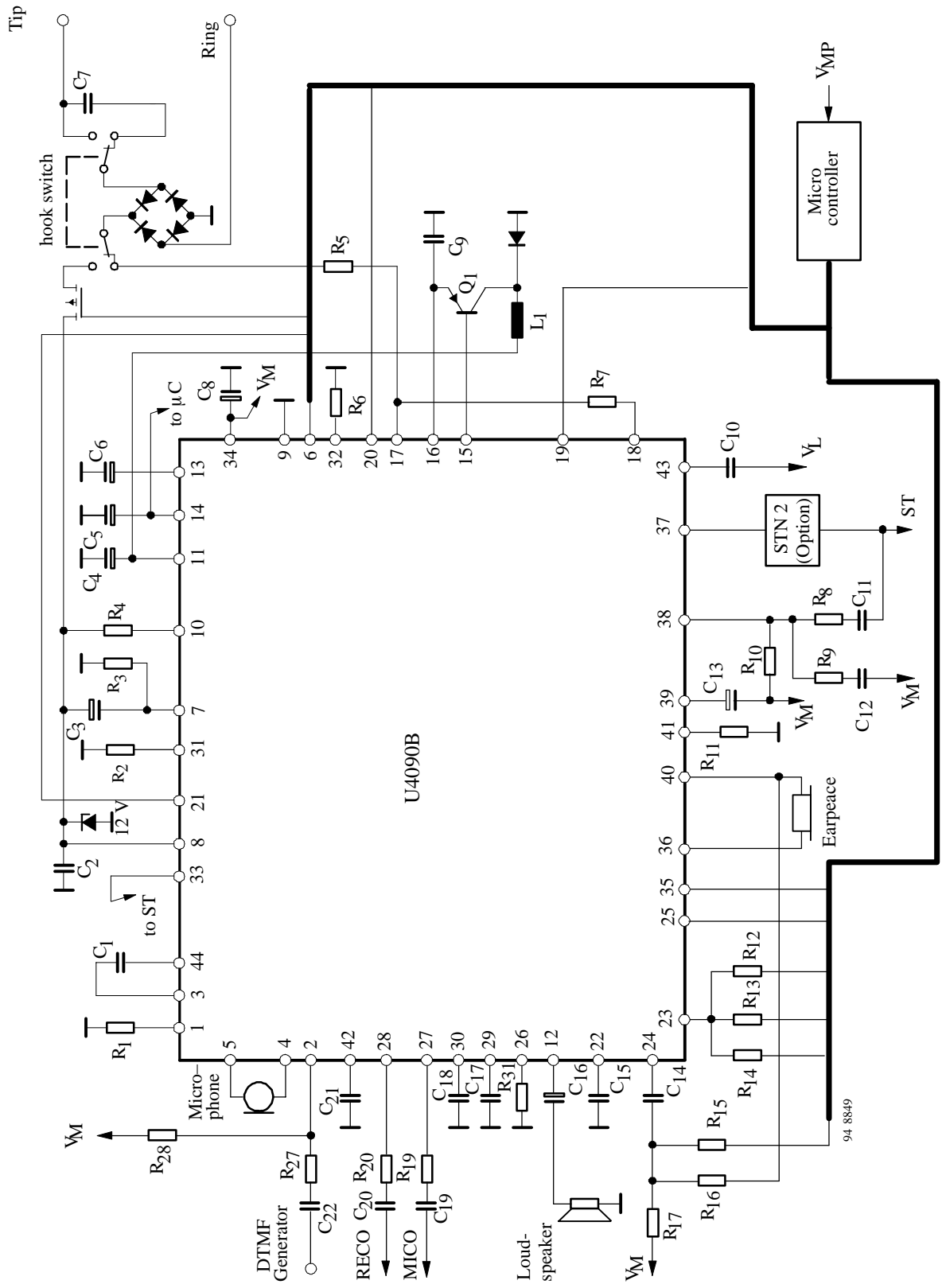

Figure 27. Application circuit for loudhearing

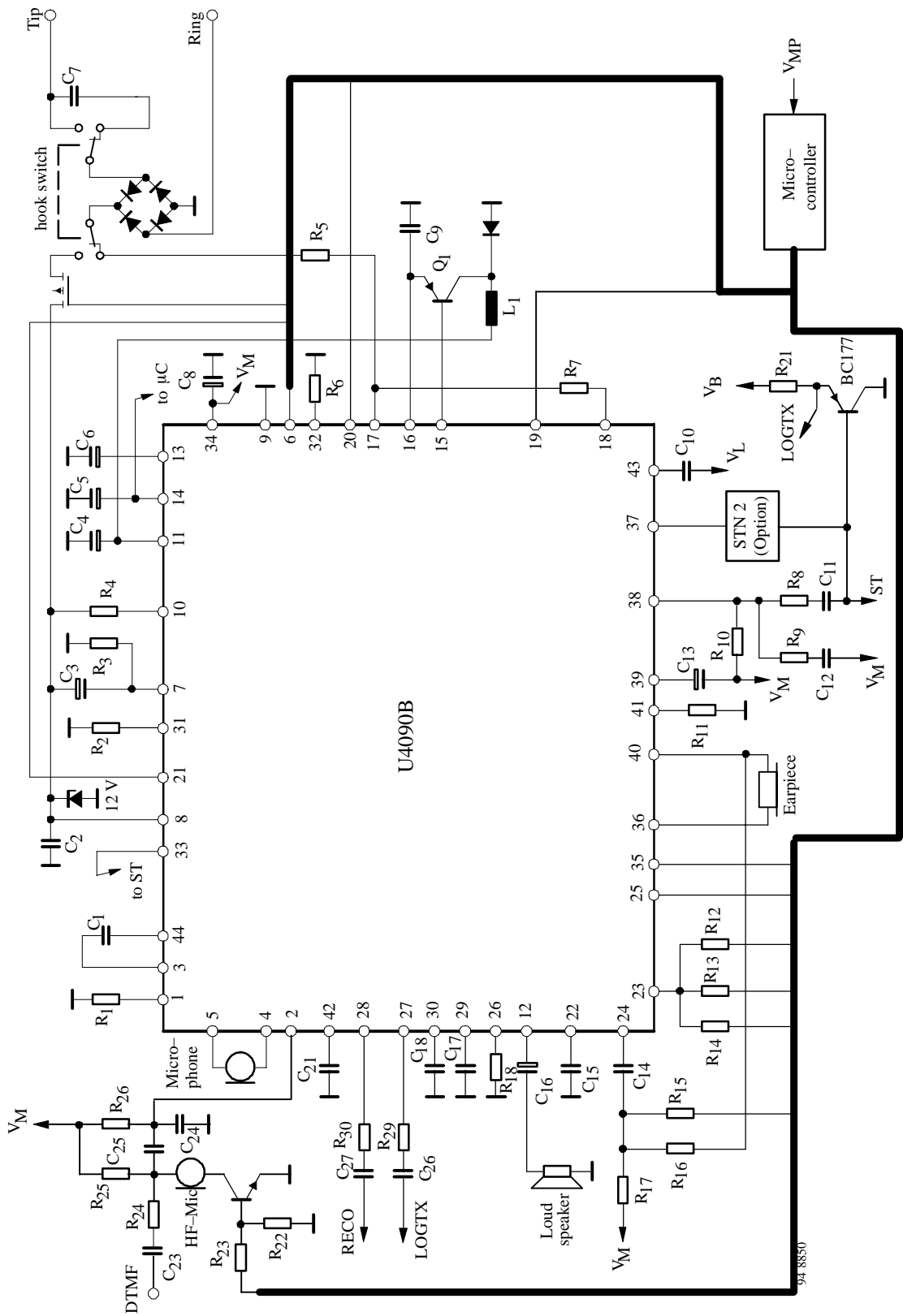

Figure 28. Application for hands-free operation

Table 7 Typical values of external components (figures 27 and 28)

Name	Value	Name	Value	Name	Value	Name	Value
C ₁	100 nF	C ₁₆	47 μF	R ₃	>68 kΩ	R ₁₈	30 kΩ
C ₂	4.7 nF	C ₁₇	10 μF	R ₄	10 kΩ	R ₁₉	6.8 kΩ
C ₃	10 μF	C ₁₈	10 μF	R ₅	1.5 kΩ	R ₂₀	6.8 kΩ
C ₄	220 μF	C ₁₉	68 nF	R ₆	62 kΩ	R ₂₁	15 kΩ
C ₅	47 μF	C ₂₀	68 nF	R ₇	680 kΩ	R ₂₂	330 kΩ
C ₆	470 μF	C ₂₁	1 μF	R ₈	22 kΩ	R ₂₃	220 kΩ
C ₇	820 nF	C ₂₂	100 nF	R ₉	330 kΩ	R ₂₄	68 kΩ
C ₈	100 μF	C ₂₃	6.8 nF	R ₁₀	3 kΩ	R ₂₅	2 kΩ
C ₉	100 nF	C ₂₄	10 nF	R ₁₁	62 kΩ	R ₂₆	3.3 kΩ
C ₁₀	150 nF	C ₂₅	100 nF	R ₁₂	30 kΩ	R ₂₇	18 kΩ
C ₁₁	86 nF	C ₂₆	470 nF	R ₁₃	62 kΩ	R ₂₈	2 kΩ
C ₁₂	33 nF	C ₂₇	33 nF	R ₁₄	120 kΩ	R ₂₉	1 kΩ
C ₁₃	10 μF	L ₁	2.2 mH	R ₁₅	47 kΩ	R ₃₀	12 kΩ
C ₁₄	100 nF	R ₁	27 kΩ	R ₁₆	1 kΩ	R ₃₁	56 kΩ
C ₁₅	1 μF	R ₂	20 kΩ	R ₁₇	1.2 kΩ		

Package Information

Package SSO44

Dimensions in mm

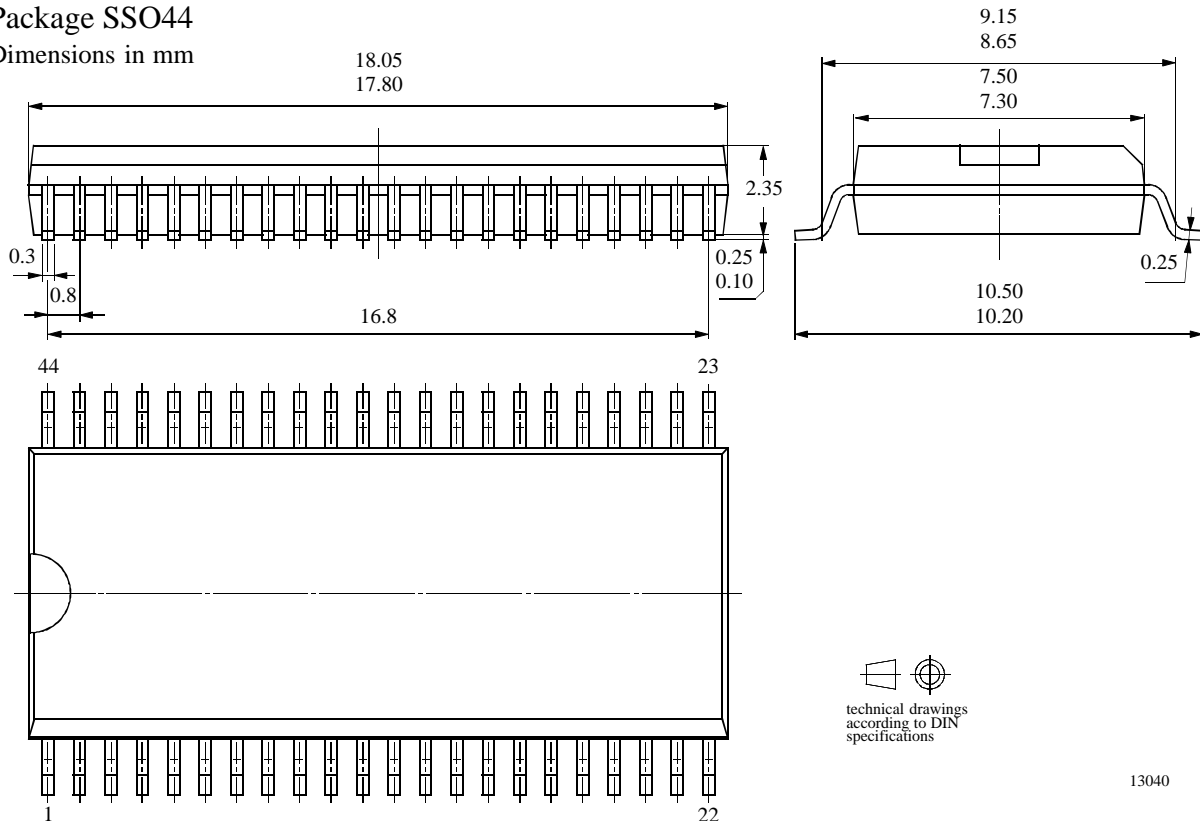

13040

Ozone Depleting Substances Policy Statement

It is the policy of **Atmel Germany GmbH** to

1. Meet all present and future national and international statutory requirements.
2. Regularly and continuously improve the performance of our products, processes, distribution and operating systems with respect to their impact on the health and safety of our employees and the public, as well as their impact on the environment.

It is particular concern to control or eliminate releases of those substances into the atmosphere which are known as ozone depleting substances (ODSs).

The Montreal Protocol (1987) and its London Amendments (1990) intend to severely restrict the use of ODSs and forbid their use within the next ten years. Various national and international initiatives are pressing for an earlier ban on these substances.

Atmel Germany GmbH has been able to use its policy of continuous improvements to eliminate the use of ODSs listed in the following documents.

1. Annex A, B and list of transitional substances of the Montreal Protocol and the London Amendments respectively
2. Class I and II ozone depleting substances in the Clean Air Act Amendments of 1990 by the Environmental Protection Agency (EPA) in the USA
3. Council Decision 88/540/EEC and 91/690/EEC Annex A, B and C (transitional substances) respectively.

Atmel Germany GmbH can certify that our semiconductors are not manufactured with ozone depleting substances and do not contain such substances.

We reserve the right to make changes to improve technical design and may do so without further notice.

Parameters can vary in different applications. All operating parameters must be validated for each customer application by the customer. Should the buyer use Atmel Wireless & Microcontrollers products for any unintended or unauthorized application, the buyer shall indemnify Atmel Wireless & Microcontrollers against all claims, costs, damages, and expenses, arising out of, directly or indirectly, any claim of personal damage, injury or death associated with such unintended or unauthorized use.

Data sheets can also be retrieved from the Internet: <http://www.atmel-wm.com>

Atmel Germany GmbH, P.O.B. 3535, D-74025 Heilbronn, Germany
Telephone: 49 (0)7131 67 2594, Fax number: 49 (0)7131 67 2423