



查询SM712.TG供应商

SEMTECH

捷多邦，专业PCB打样工厂，24小时加急出货 **SM712**

Asymmetrical TVS Diode for Extended Common-Mode RS-485

PROTECTION PRODUCTS

Description

The SM712 transient voltage suppressor (TVS) diode is designed for asymmetrical (12V to -7V) protection in multi-point data transmission standard RS-485 applications. The SM712 may be used to protect devices from transient voltages resulting from electrostatic discharge (ESD), electrical fast transients (EFT), and lightning.

The SM712 features 400 Watts ($t_p = 8/20\mu s$) of power handling capability to accommodate the higher transient voltage levels which may be expected in extended common mode applications. This provides higher equipment reliability and eliminates the "guess work" required when using zener diodes that are not rated to handle such transient conditions.

The SM712 replaces four discrete components by integrating two 12V and two 7V TVS diodes in a single package. The integrated design aids in reducing voltage over-shoot associated with trace inductance. The low clamping voltage of the SM712 minimizes the stress on the protected transceiver. The SOT23 package allows flexibility in the design of "crowded" circuit boards.

Features

- ◆ 400 watts peak pulse power ($t_p = 8/20\mu s$)
- ◆ Transient protection for asymmetrical data lines to **IEC 61000-4-2 (ESD) 15kV (air), 8kV (contact)**
IEC 61000-4-4 (EFT) 40A (t5/50ns)
IEC 61000-4-5 (Lightning) 12A (8/20μs)
- ◆ Protects two +12V to -7V lines
- ◆ Low capacitance
- ◆ Low clamping voltage
- ◆ Solid-state silicon avalanche technology

Mechanical Characteristics

- ◆ JEDEC SOT23 package
- ◆ Molding compound flammability rating: UL 94V-0
- ◆ Marking : 712
- ◆ Packaging : Tape and Reel per EIA 481

Applications

- ◆ Protection of RS-485 transceivers with extended common-mode range
- ◆ Security systems
- ◆ Automatic Teller Machines
- ◆ HFC systems
- ◆ Networks

Circuit Diagram

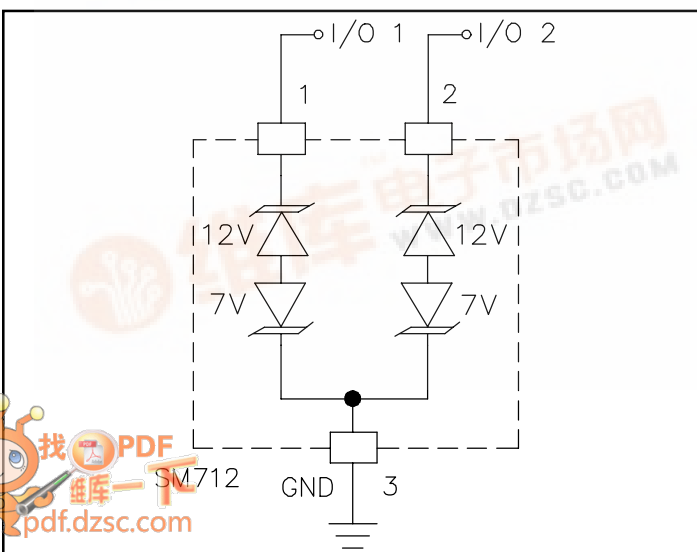

Schematic & PIN Configuration

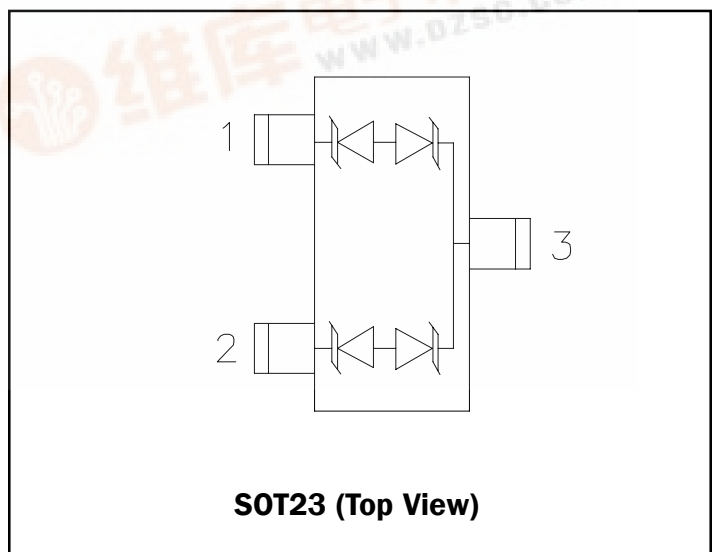

PROTECTION PRODUCTS
Absolute Maximum Rating

Rating	Symbol	Value	Units
Peak Pulse Power (tp = 8/20μs)	P _{pk}	400	Watts
Peak Pulse Current (tp = 8/20μs)	I _{pp}	17	A
Lead Soldering Temperature	T _L	260 (10 sec.)	°C
Operating Temperature	T _J	-55 to +125	°C
Storage Temperature	T _{STG}	-55 to +150	°C

Electrical Characteristics

SM712									
			Pins 1 to 3 and 2 to 3 (12V TVS)			Pins 3 to 1 and 3 to 2 (7V TVS)			
Parameter	Symbol	Conditions	MIN	TYP	MAX	MIN	TYP	MAX	Units
Reverse Stand-Off Voltage	V _{RWM}	Pin 3 to 1 or Pin 2 to 1			12			7	V
Reverse Breakdown Voltage	V _{BR}	I _{PT} = 1mA	13.3			7.5			V
Reverse Leakage Current	I _R	V _R = V _{RWM}			1			20	μA
Clamping Voltage	V _C	I _{pp} = 5A, tp = 8/20μs			20			10	V
Clamping Voltage	V _C	I _{pp} = 17A, tp = 8/20μs			26			12	V
Junction Capacitance	C _J	V _R = 0V, f = 1MHz			75			75	pF
		V _R = V _{RWM} , f = 1MHz		45			45		pF

PROTECTION PRODUCTS

Typical Characteristics

Non-Repetitive Peak Pulse Power vs. Pulse Time

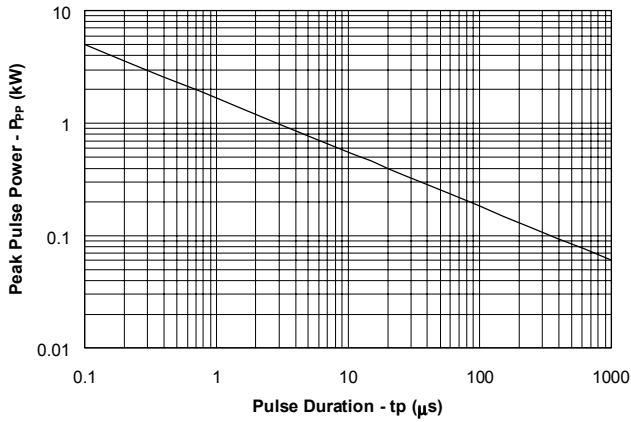

Power Derating Curve

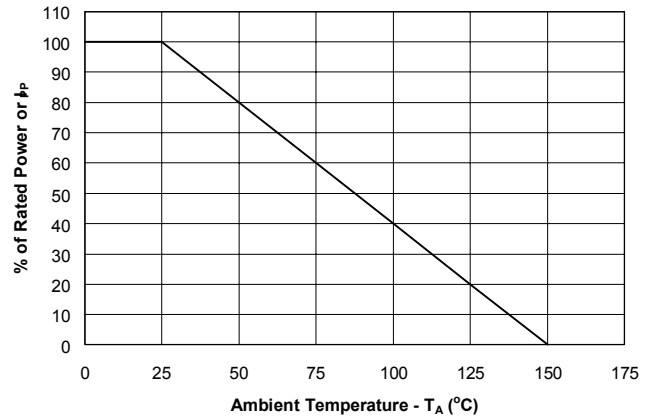

Pulse Waveform

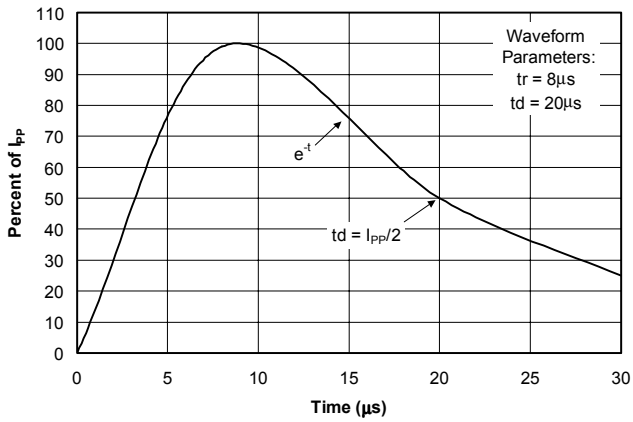

Clamping Voltage vs. Peak Pulse Current

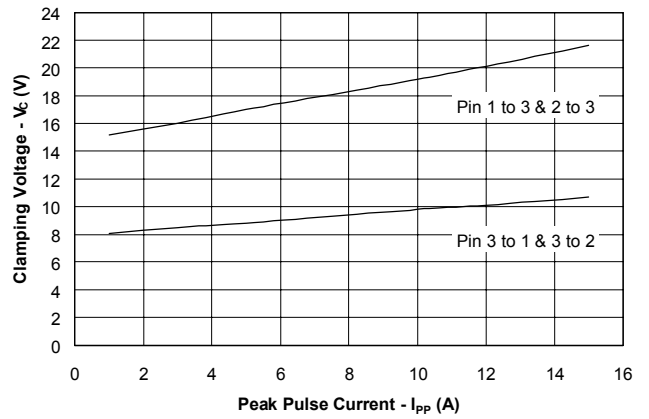

Capacitance vs. Reverse Voltage

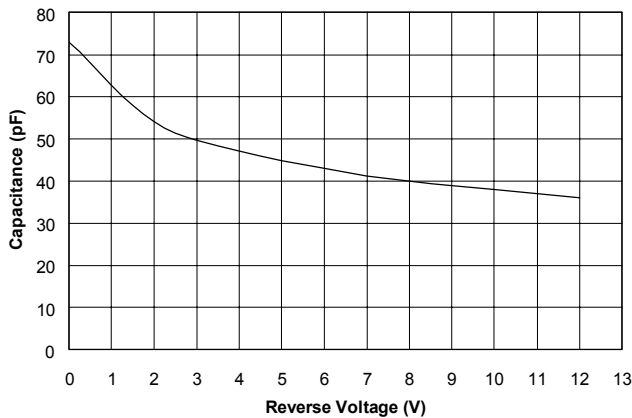

PROTECTION PRODUCTS

Applications Information

Device Connection for Protection of Two RS-485 Data Lines

EIA RS-485 specifies a $\pm 7V$ ground difference between devices on the bus. This permits the bus voltage to range from +12V (5V + 7V) to -7V (0 - 7V).

The SM712 is designed to protect two RS-485 data lines in extended common mode applications. The SM712 may be used to protect devices from transient voltages resulting from ESD, EFT, and lightning. The device is designed with asymmetrical operating voltages for optimum protection. The TVS diodes at pins 1 & 2 have a working voltage of 12 volts. These pins are connected to the differential data line pairs. The TVS diodes at pin 3 have a working voltage of 7 volts. Pin 3 is connected to ground. The internal TVS diodes of the SM712 will protect the transceiver input from positive transient voltage spikes greater than 12V and negative spikes greater than 7V.

A series current limiting resistor may be added in applications requiring enhanced surge immunity.

Circuit Board Layout Recommendations.

Good circuit board layout is critical for the suppression of fast rise-time transients such as ESD. The following guidelines are recommended:

- Place the SM712 near the input terminals or connectors to restrict electromagnetic coupling.
- Minimize the path length between the SM712 and the protected line. This minimizes voltage overshoot due to parasitic inductance of board traces.
- Use ground planes whenever possible.
- Long, single trace ground conductors should be avoided. The ground pin (Pin 3) should be connected directly to a ground plane on the circuit board for best results.
- Minimize all conductive loops including power and ground loops.
- Never run critical signals near board edges.

RS-485 Common Mode Voltages

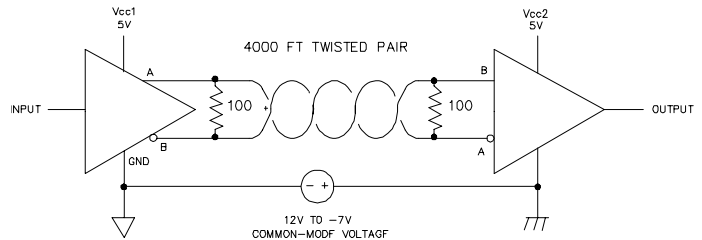

RS-485 Protection Circuit

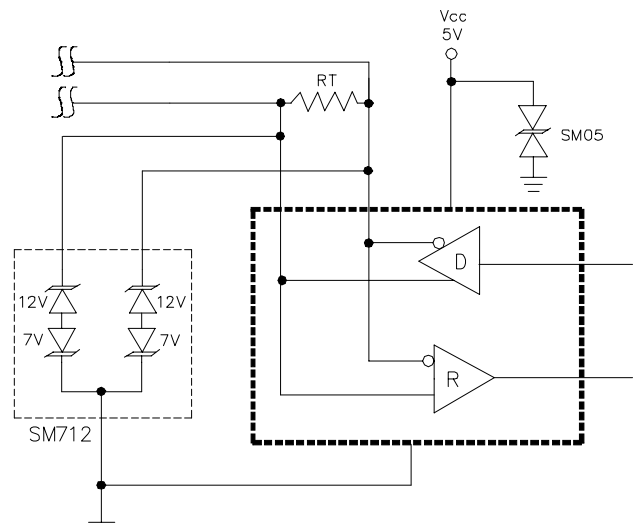

PROTECTION PRODUCTS

Outline Drawing - SOT23

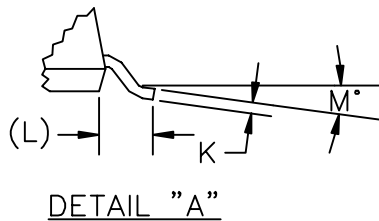
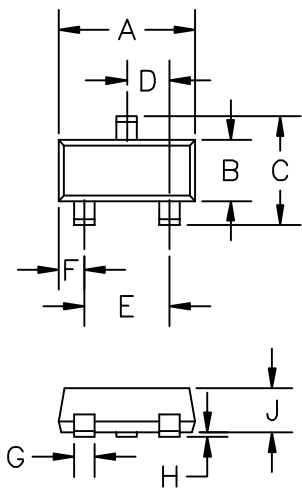

SEE DETAIL "A"

DIM ^N	DIMENSIONS [1]				NOTE
	INCHES		MM		
	MIN	MAX	MIN	MAX	
A	.110	.119	2.8	3.04	—
B	.047	.055	1.20	1.40	—
C	.083	.104	2.10	2.64	—
D	.035	.040	0.88	1.02	—
E	.070	.081	1.78	2.05	—
F	.017	.024	.44	.60	—
G	.014	.020	.37	.51	—
H	.0005	.004	.013	0.10	—
J	.034	.040	.87	1.02	—
K	.003	.007	.085	.180	—
L	—	.022	—	0.55	REF
M	0	8°	0	8°	—

Land Pattern - SOT23

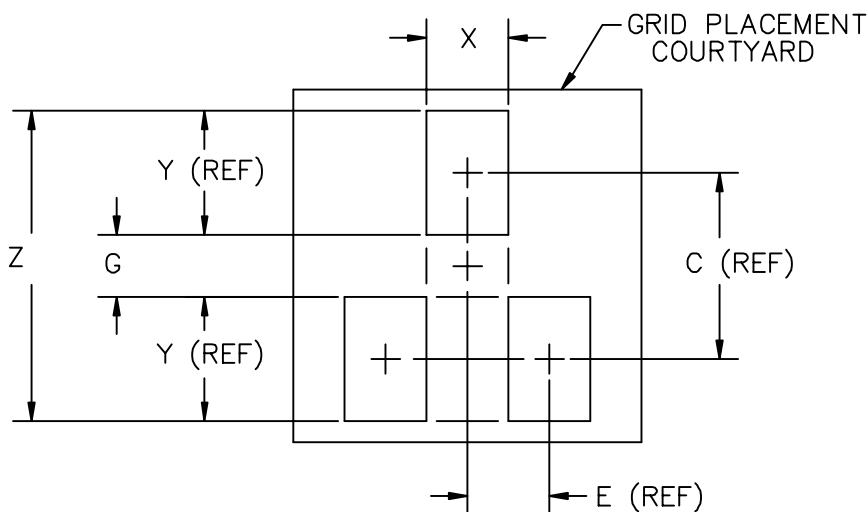

DIM ^N	DIMENSIONS				NOTE
	INCHES		MM		
	MIN	MAX	MIN	MAX	
C	—	.09	—	2.20	—
E	—	.04	—	.95	—
G	.03	.04	.80	1.00	—
X	.03	.04	.80	1.00	—
Y	—	.06	—	1.40	—
Z	.14	.15	3.40	3.60	—

Note 1 : Grid placement courtyard is 8 x 8 elements (4mm x 4mm) in accordance with the international grid detailed in IEC Publication 97.



SM712

PROTECTION PRODUCTS

Ordering Information

Part Number	Qty per Reel	Reel Size
SM712.TC	3,000	7 Inch
SM712.TG	10,000	13 Inch

Contact Information

Semtech Corporation
Protection Products Division
652 Mitchell Rd., Newbury Park, CA 91320
Phone: (805)498-2111 FAX (805)498-3804