

Low Input Voltage, Single Synchronous Buck Pulse-Width Modulation (PWM) Controller

The ISL6406/26 is an adjustable frequency, synchronous buck switching regulator optimized for generating lower voltages for the distributed DC-DC architectures. The ISL6406 offers an adjustable output voltage, while the ISL6426 provides a fixed 1.8V output.

Designed to drive N-Channel MOSFETs in synchronous buck topology, the ISL6406/26 integrates the control, output adjustment and protection functions into a single package.

The ISL6406/26 provides simple, single feedback loop, voltage-mode control with fast transient response. The output voltage can be precisely regulated to as low as 0.8V, with a maximum tolerance of $\pm 1.5\%$ over temperature and line voltage variations.

The error amplifier features a 15MHz gain-bandwidth product and 6V/ μ s slew rate which enables high converter bandwidth for fast transient performance.

Protection from overcurrent conditions is provided by monitoring the $r_{DS(ON)}$ of the upper MOSFET to inhibit PWM operation appropriately. This approach simplifies the implementation and improves efficiency by eliminating the need for a current sense resistor.

The wide programmable switching frequency range of 100kHz to 700kHz allows the use of small surface mount inductors and capacitors. The device also provides external frequency synchronization making it an ideal choice for DC-DC converter applications.

Ordering Information

PART NUMBER	TEMP. RANGE (°C)	PACKAGE	PKG. NO.
ISL6406CB	0 to 70	16 Ld SOIC	M16.15
ISL6406IB	-40 to 85	16 Ld SOIC	M16.15
ISL6406CR	0 to 70	16 Ld QFN	L16.5x5B
ISL6406IR	-40 to 85	16 Ld QFN	L16.5x5B
ISL6406CV	0 to 70	16 Ld TSSOP	M16.173
ISL6406IV	-40 to 85	16 Ld TSSOP	M16.173
ISL6426CB	0 to 70	16 Ld SOIC	M16.15
ISL6426IB	-40 to 85	16 Ld SOIC	M16.15
ISL6426CR	0 to 70	16 Ld QFN	L16.5x5B
ISL6426IR	-40 to 85	16 Ld QFN	L16.5x5B
ISL6426CV	0 to 70	16 Ld TSSOP	M16.173
ISL6426IV	-40 to 85	16 Ld TSSOP	M16.173

Features

- Operates from 3.3V Input
- 0.8V to V_{IN} Output Range
 - 0.8V Internal Reference
 - $\pm 1.5\%$ Over Load, Line Voltage and Temperature
- Simple Single-Loop Control Design
 - Voltage-Mode PWM Control
- Fast Transient Response
 - High-Bandwidth Error Amplifier
 - Full 0% to 100% Duty Cycle
- Lossless, Programmable Overcurrent Protection
 - Uses Upper MOSFET's $r_{DS(on)}$
- Programmable Switching Frequency 100–700kHz
- External Frequency Synchronization
- Two Device Options Available
 - ISL6406 Adjustable Output Voltage
 - ISL6426 Fixed 1.8V Output
- No External Current Sense Resistor Required
- Internal Soft-Start
- QFN Package:
 - Compliant to JEDEC PUB95 MO-220 QFN - Quad Flat No Leads - Product Outline
 - Near Chip Scale Package Footprint; Improves PCB Efficiency, Thinner in Profile

Applications

- DC-DC Converter Modules
- Broadband Customer Premise Equipment
- Distributed DC-DC 3.3V, 2.5V and 1.8V Power Architectures for DSP, Logic, and Memory
- Power Supplies for Microprocessors
 - PCs
 - Embedded Controllers
- Integrated Access Devices
- Memory Supplies
- Personal Computer Peripherals
- Industrial Power Supplies



ISL6406, ISL6426

Pinouts

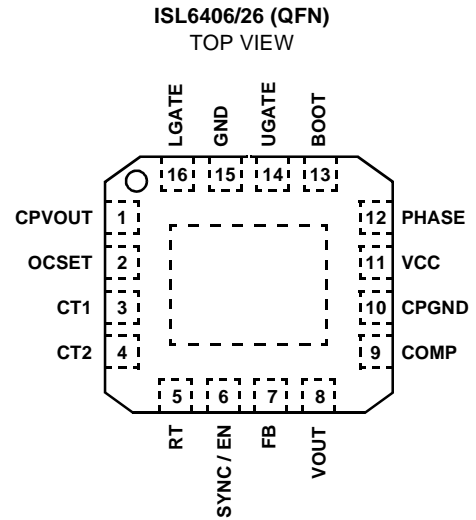
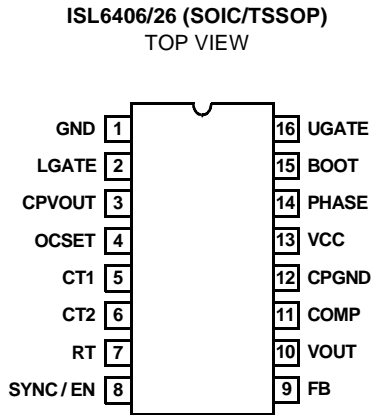

Functional Block Diagram

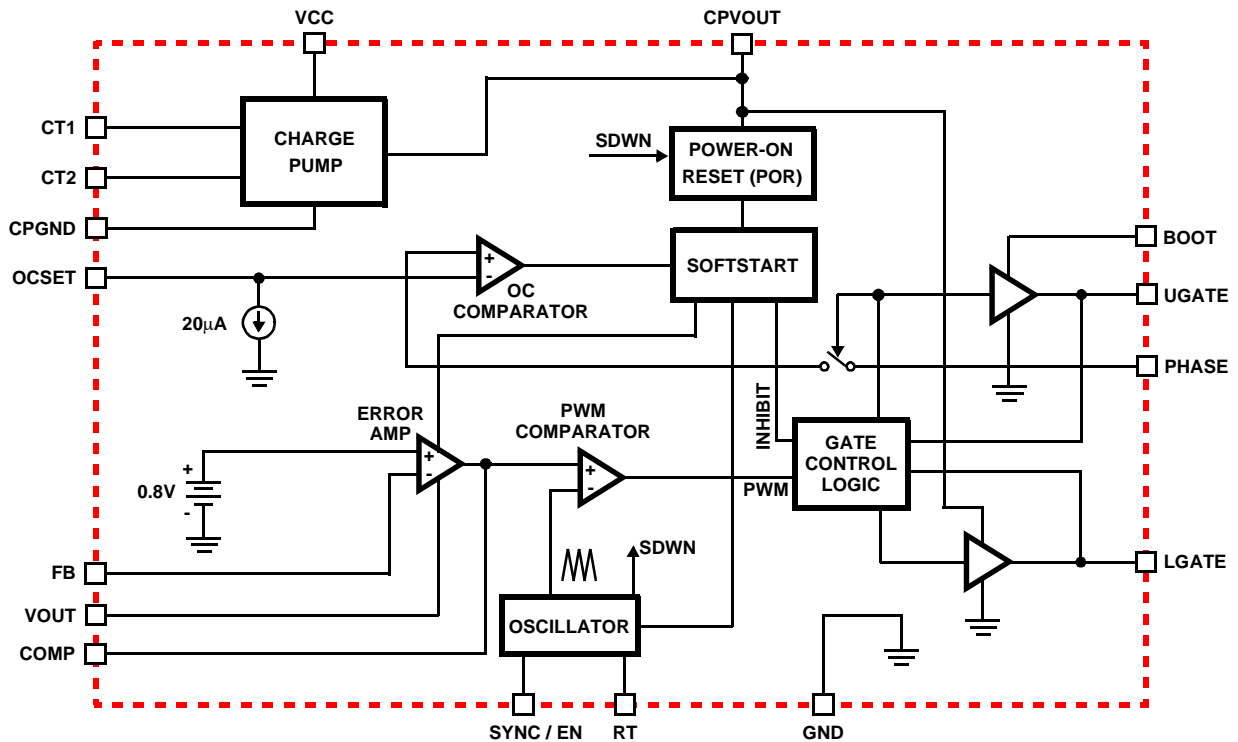

All Intersil products are manufactured, assembled and tested utilizing ISO9000 quality systems.
Intersil Corporation's quality certifications can be viewed at www.intersil.com/design/quality

Intersil products are sold by description only. Intersil Corporation reserves the right to make changes in circuit design and/or specifications at any time without notice. Accordingly, the reader is cautioned to verify that data sheets are current before placing orders. Information furnished by Intersil is believed to be accurate and reliable. However, no responsibility is assumed by Intersil or its subsidiaries for its use; nor for any infringements of patents or other rights of third parties which may result from its use. No license is granted by implication or otherwise under any patent or patent rights of Intersil or its subsidiaries.

For information regarding Intersil Corporation and its products, see www.intersil.com