

[查询PM7322供应商](#)

[捷多邦, 专业PCB打样工厂, 24小时加急出货](#)

APPLICATION NOTE

PMC PMC-Sierra, Inc.

PM7322 RCMP-800

ISSUE 1

3.3V SRAM INTERFACE FOR RCMP-800

PM7322

3.3V SRAM INTERFACE FOR RCMP-800

Issue 1: October 7, 1996

TABLE OF CONTENTS

REFERENCE ii

INTRODUCTION 1

CIRCUIT DESCRIPTION 1

SUMMARY 3

NOTES 4

REFERENCE

- [1] PMC-940904, "PM7322 RCMP-800 Datasheet", Issue 5, PMC-Sierra Inc.
- [2] App. Note 1, "Zero Delay Bus Switches", Pericom Databook.
- [3] AN-966, "Using the Bus Switch as a 5V to 3V Translator", National Semiconductor

INTRODUCTION

The choice of Synchronous SRAM's to be used with the RCMP-800 (which will be referred to as simply RCMP¹) is important from both a technical and cost perspective. Currently, 3.3V Synchronous SRAM's are becoming more common, as mainly driven by demand in the PC market. In general, 3.3V SRAM's dissipate lower power, and have lower costs due to higher levels of integration. However, the majority of these 3.3V SRAM's are not 5V I/O tolerant. In order for the 5V RCMP to take advantage of these 3.3V SRAM's, simple level-translation logic can be used to overcome this 5V tolerance problem.

This appnote illustrates how the RCMP can be interfaced to 3.3V Synchronous SRAM's, using very low-power, close to zero-delay bus switches.

CIRCUIT DESCRIPTION

Fig.1 shows 5V-to-3.3V interface between the 5V RCMP and 3.3V SRAM's. It illustrates how any signal, uni-directional or bi-directional, can be connected between the 5V circuitry (the RCMP) and the 3.3V circuitry (the SRAM). For the RCMP SRAM interface, the relevant signals are the address, data, control (address strobe, write strobe, output enable) and clock.

Fig. 1 5V-to-3.3V Level-Translation Interface

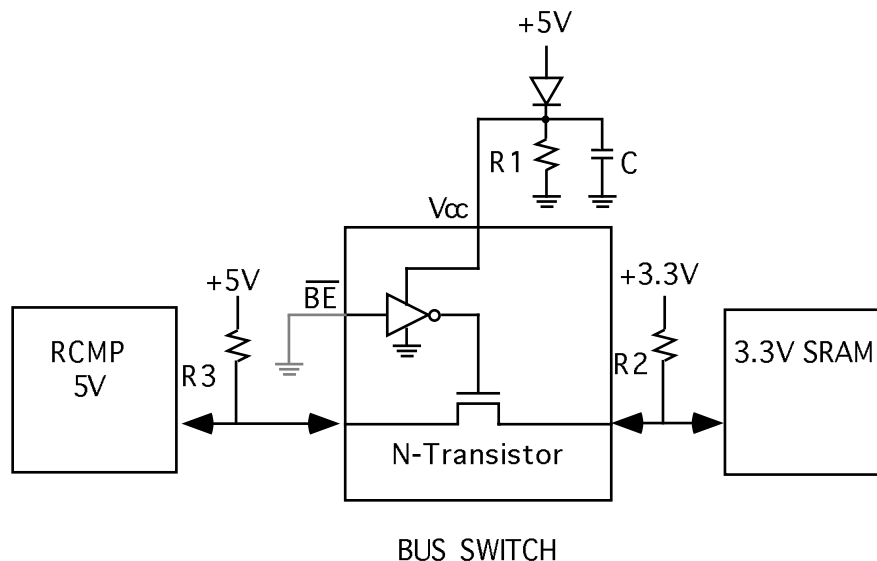

¹Note that this appnote applies equally to PM7323, the RCMP-200.

The bus switch shown is simply a N-transistor with its gate controlled by the byte-enable (BE, active-low) input. The byte-enable is tied low in this application, which causes the gate of the transistor to be high. The transistor will turn on if either the drain or the source is one threshold voltage (V_T) below the gate. The source and drain act as the I/O ports of this level translator. When the transistor is turned on, the switch becomes a very low series resistance, typically about 5 ohms, which in effect connects the input directly to the output. The switch acts as a level translator by clamping the signal level at the I/O's to at most one V_T below the V_{CC} . By changing the V_{CC} , the user can therefore control the maximum voltage seen at the I/O's. Since the switch becomes effectively only a resistor, there is close-to-zero delay (max. 250ps) incurred. Also, typical power dissipation is extremely low, about 0.1mA, or 0.2uA for low-power versions. The switch is inherently bidirectional since the transistor is symmetric.

As shown in Fig. 1, V_{CC} is limited to about 4.3V by the diode from the 5V supply. A diode that can maintain a constant voltage drop, such as the IN4001, would be suitable. R1 provides the forward biasing current for the diode, in order to maintain a constant voltage drop across the diode. A typical value for R1 is 2.2K ohm. The bypass capacitor, C, provides decoupling for the reduced V_{CC} . A typical value for C is 0.01uF. Also, optionally, R2 can be used to pull-up the signal on the 3.3V side, to ensure that the high voltage level will be close to 3.3V. Similarly, R3 can be used to pull-up the signal on the 5V side to give a 5V high voltage level. Typical value for R2 and R3 is 1K ohm.

Table 1 shows a list of vendors offering a variety of these bus switches². The most common version is the dual 5-bit bus switch, the 3384, which all four vendors offer. Pericom and Quality Semiconductor have the largest selection of bus switches, tailored for many applications. The parameters that distinguish these bus switches are: power dissipation, configuration, package, and on-resistance. In particular, there are 25-ohm on-resistance versions that provide series resistance to help reduce reflections, which can be applicable to clock signals. Also, the variety of packages allow the user to optimize the board area, or to maintain footprint compatibility with devices such as 74XXX245.

²All of the listed vendors have Internet web pages available.

Table 1 Bus Switch Vendors

| Vendor | Part Number | Configuration | ICCQ (Typ.) | Package |
|---|-------------|---------------|-------------|-------------------------|
| Cypress | CYBUS3384 | Dual 5-bit | 0.1mA | 24 DIP/SOIC/QSOP |
| | CYBUS3L384 | Dual 5-bit | 0.2uA | 24 DIP/SOIC/QSOP |
| National Semi. | 74LVX3L384 | Dual 5-bit | 0.2uA | 24 DIP/SOIC/QSOP |
| Pericom (25 ohm) (Flow-Through Pinout) | PI5C3384 | Dual 5-bit | 0.2uA | 24 DIP/SOIC/QSOP |
| | PI5C32384 | Dual 5-bit | 0.2uA | 24 DIP/SOIC/QSOP/TSSOP |
| | PI5C32X384 | Dual 10-bit | 0.2uA | 48 TSSOP |
| | PI5C3861 | Single 10-bit | 0.2uA | 24 SOIC/QSOP |
| | PI5C16861 | Dual 10-bit | 0.2uA | 48 SSOP/TSSOP |
| Quality Semi. (25 ohm) (Flow-Through Pinout) | QS3384 | Dual 5-bit | 1.5mA(max) | 24 PDIP/SOIC/QSOP/HQSOP |
| | QS3L384 | Dual 5-bit | 0.2uA | 24 PDIP/SOIC/QSOP |
| | QS32384 | Dual 5-bit | 1.5mA(max) | 24 PDIP/SOIC/QSOP/HQSOP |
| | QS32X384 | Dual 10-bit | 3mA(max) | 48 QVSOP |
| | QS3861 | Single 10-bit | 3uA | 24 SOIC/QSOP |

For the RCMP SRAM interface, the total number of signals that needs to be level-translated will be: 20 bits address, 45 bits of data, 3 control signals and a clock, which is equal to 69 bits. In this case, 3 of the dual 10-bit switches and 1 of the single 10-bit switches can be used to provide this interface.

SUMMARY

This appnote shows how the RCMP can be interfaced to 3.3V SRAM's using very simple bus switches. These switches incur almost zero delay, and dissipate very little power. Also, the board area needed can be minimized with the small packages available.

NOTES

Contact us for applications support:

FAX: (604) 415-6206

PHONE: (604) 415-6000

Email: apps@pmc-sierra.bc.ca

Website: <http://www.pmc-sierra.com>

Seller will have no obligation or liability in respect of defects or damage caused by unauthorized use, mis-use, accident, external cause, installation error, or normal wear and tear. There are no warranties, representations or guarantees of any kind, either express or implied by law or custom, regarding the product or its performance, including those regarding quality, merchant ability, fitness for purpose, condition, design, title, infringement of third-party rights, or conformance with sample. Seller shall not be responsible for any loss or damage of whatever nature resulting from the use of, or reliance upon, the information contained in this document. In no event will Seller be liable to Buyer or to any other party for loss of profits, loss of savings, or punitive, exemplary, incidental, consequential or special damages, even if Seller has knowledge of the possibility of such potential loss or damage and even if caused by Seller's negligence.

© 1996 PMC-Sierra, Inc.

PMC-961022P1

Issue date: October 7, 1996

Printed in Canada