

Ordering number : ENN7117A

Monolithic Digital IC



LB11983

3-Phase Sensorless Motor Driver for Fan Motor Driver for Refrigerator

Overview

The LB11983 is a 3-phase full-wave current linear sensorless motor driver. It is optimal for refrigerator fan motor drive.

Features

- current linear driving technique
- current limiter circuit
- Over saturation prevention circuit for output stage
- Provides coil back EMF FG output
- Thermal shutdown circuit
- Beat lock prevention circuit

Package Dimensions

unit: mm

3021C-DIP20

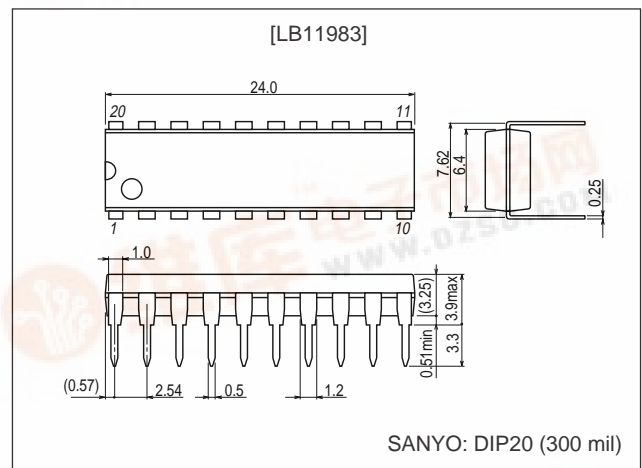

Specifications

Absolute Maximum Ratings at Ta = 25°C

Parameter	Symbol	Conditions	Ratings	Unit
Supply voltage	V_{CC} max		14.5	V
Output application voltage	V_O max		14.5	V
Input application voltage	V_I max		-0.3 to $V_{CC} + 0.3$	V
Output current	I_O max		1.0	A
Internal allowable loss	P_d max	Independent IC	1.0	W
Operating temperature	T_{opr}		-30 to +85	°C
Storage temperature	T_{stg}		-55 to +150	°C

Operating Conditions at Ta = 25°C

Parameter	Symbol	Conditions	Ratings	Unit
Supply voltage	V_{CC}		7 to 13.8	V

- Any and all SANYO products described or contained herein do not have specifications that can handle applications that require extremely high levels of reliability, such as life-support systems, aircraft's control systems, or other applications whose failure can be reasonably expected to result in serious physical and/or material damage. Consult with your SANYO representative nearest you before using any SANYO products described or contained herein in such applications.
- SANYO assumes no responsibility for equipment failures that result from using products at values that exceed, even momentarily, rated values (such as maximum ratings, operating condition ranges, or other parameters) listed in products specifications of any and all SANYO products described or contained herein.



LB11983

Electrical Characteristics at Ta = 25°C, VCC = 12.0 V

Parameter	Symbol	Conditions	Ratings			Unit
			min	typ	max	
Supply current	I _{CC}	V _C = V _{CC}		20	30	mA
Output saturation voltage 1	V _{Osat1}	I _O = 0.4 A, Source + Sink		1.4	2.0	V
Output saturation voltage 2	V _{Osat2}	I _O = 0.8 A, Source + Sink, R _F = 0 Ω		1.8	2.6	V
MCOM pin common-mode input voltage range	V _{IC}		0		V _{CC} - 2	V
PCOUT output current 1	IPCOU	Source side		-90		μA
PCOUT output current 2	IPCOD	Sink side		90		μA
VCOIN input current	IVCOIN	VCOIN = 5 V		0.1	0.2	μA
VCO minimum frequency	fVCOMIN	VCOIN = open		400		Hz
VCO maximum frequency	fVCOMAX	VCOIN = 5 V		18.5		kHz
C1, C2 source current ratio	RSOURCE	IC1SOURCE/IC2SOURCE	-12		+12	%
C1, C2 sink current ratio	RSINK	IC1SINK/IC2SINK	-12		+12	%
C1 source and sink current ratio	RC1	IC1SOURCE/IC1SINK	-35		+15	%
C2 source and sink current ratio	RC2	IC2SOURCE/IC2SINK	-35		+15	%
Counter FG output ON voltage	V _{OL}				0.4	V
Counter FG output OFF voltage	V _{OH}		4			V
Thermal shutdown operating temperature	TTSD	Design target value*	150	180	210	°C
Thermal shutdown hysteresis	ΔTTSD	Design target value*		15		°C

Note*: These items are design target values and are not tested.

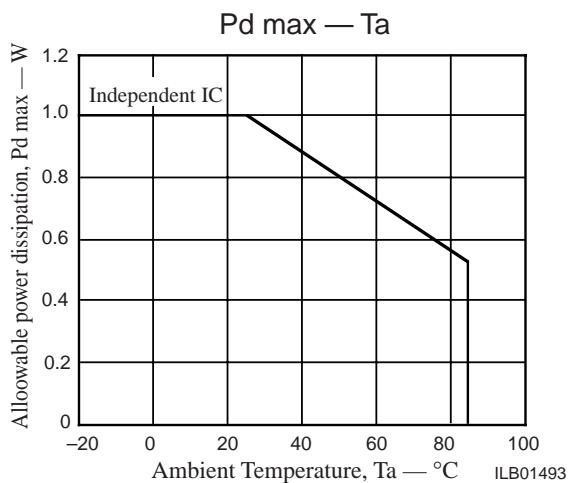

LB11983

Pin Arrangement

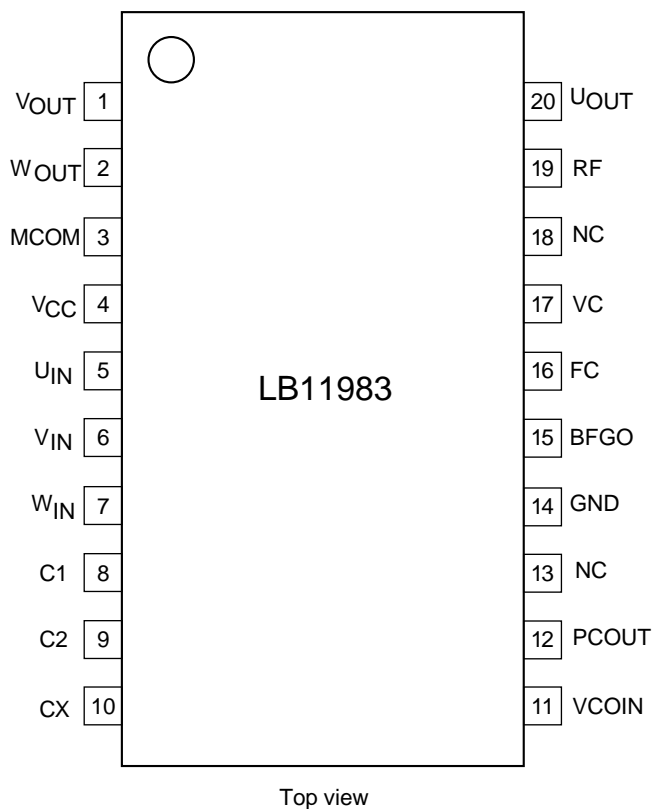

Pin Functions

Pin No.	Symbol	Pin voltage	Description	Equivalent circuit
20	U_{OUT}		Drum motor driver output pin.	
1	V_{OUT}			
2	W_{OUT}			
19	RF		Minimum potential of the drum motor driver output transistor. This voltage is detected for constant-current control. The current limiter is also activated upon detection of this potential.	
4	V_{CC}	8 to 13.8 V	Power supply pin	

Continued on next page.

LB11983

Continued from preceding page.

Pin No.	Symbol	Pin voltage	Description	Equivalent circuit
3	MCOM		Middle point input pin of motor coil. The coil waveform is detected with reference to this voltage.	
5	U_{IN}		Input pin of the coil waveform detection comparator. Connected to each phase output with a built-in resistor of 10 k Ω	
6	V_{IN}			
7	W_{IN}			
8	C1		Triangular wave generating capacitor connection pin. This triangular wave causes soft switching of coil output waveform.	
9	C2			
10	CX		The operating frequency range and minimum operating frequency are determined from the value of capacitor connected to this pin and GND in the VCO circuit.	
11	VCOIN		VCO circuit voltage input pin Inputs the PCOUT pin voltage through CR filtering.	

Continued on next page.

LB11983

Continued from preceding page.

Pin No.	Symbol	Pin voltage	Description	Equivalent circuit
12	PCOUT		VCO circuit PLL output pin.	
14	GND		GND for others than the output transistor.	
15	BFGO		FG output to detect motor reverse feeder voltage. (Composition of three phases)	
16	FC		Frequency characteristics compensation pin. Insertion of a capacitor between this pin and GND stops oscillation of the current control closed loop.	
17	VC		Speed control pin. The control is a constant-current control under current feedback from RF. Normally, this pin is connected to V _{CC} for use.	

Block Diagram (External constant may vary depending on the motor used.)

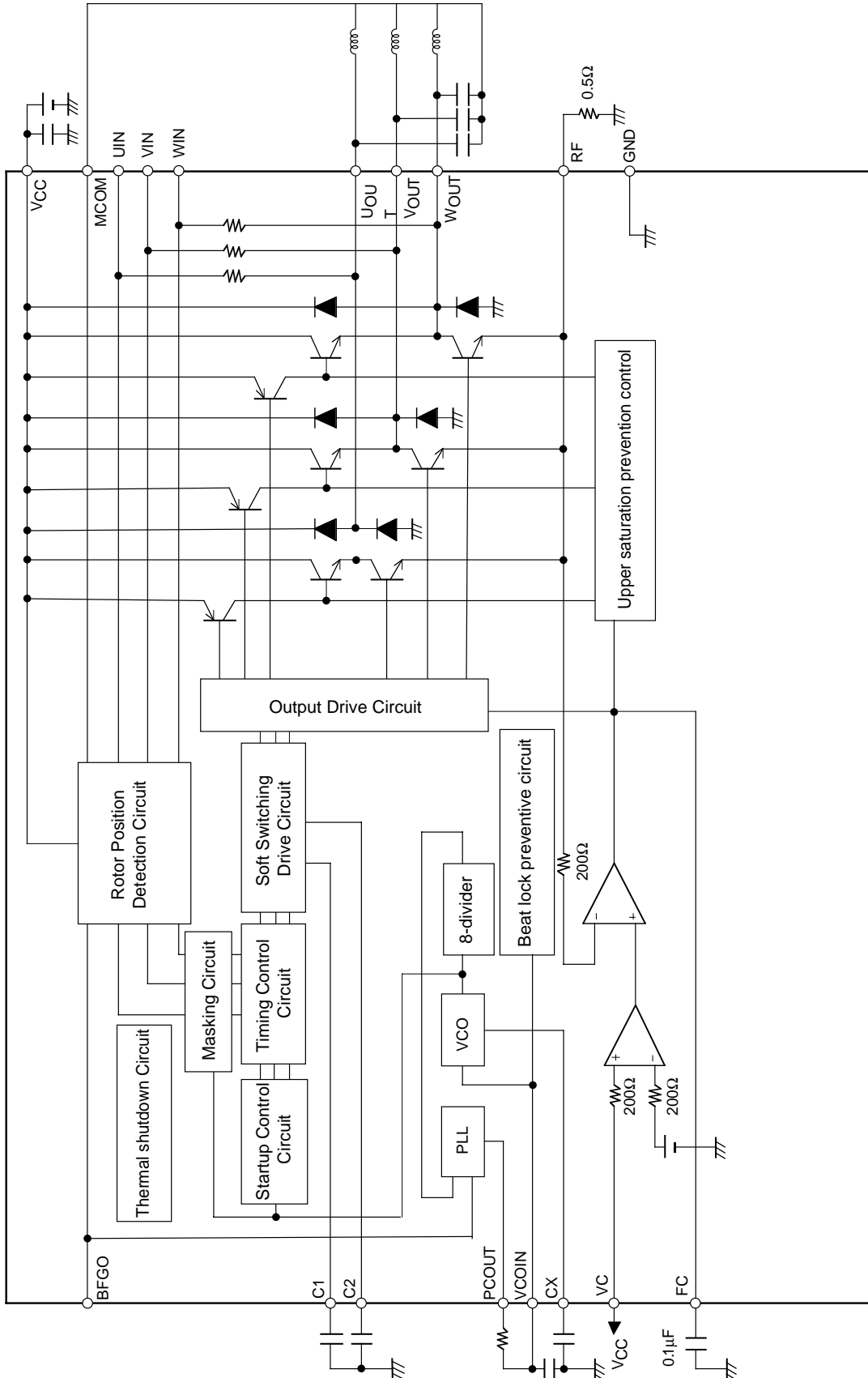

LB11983

Sample Application Circuit (Reference)

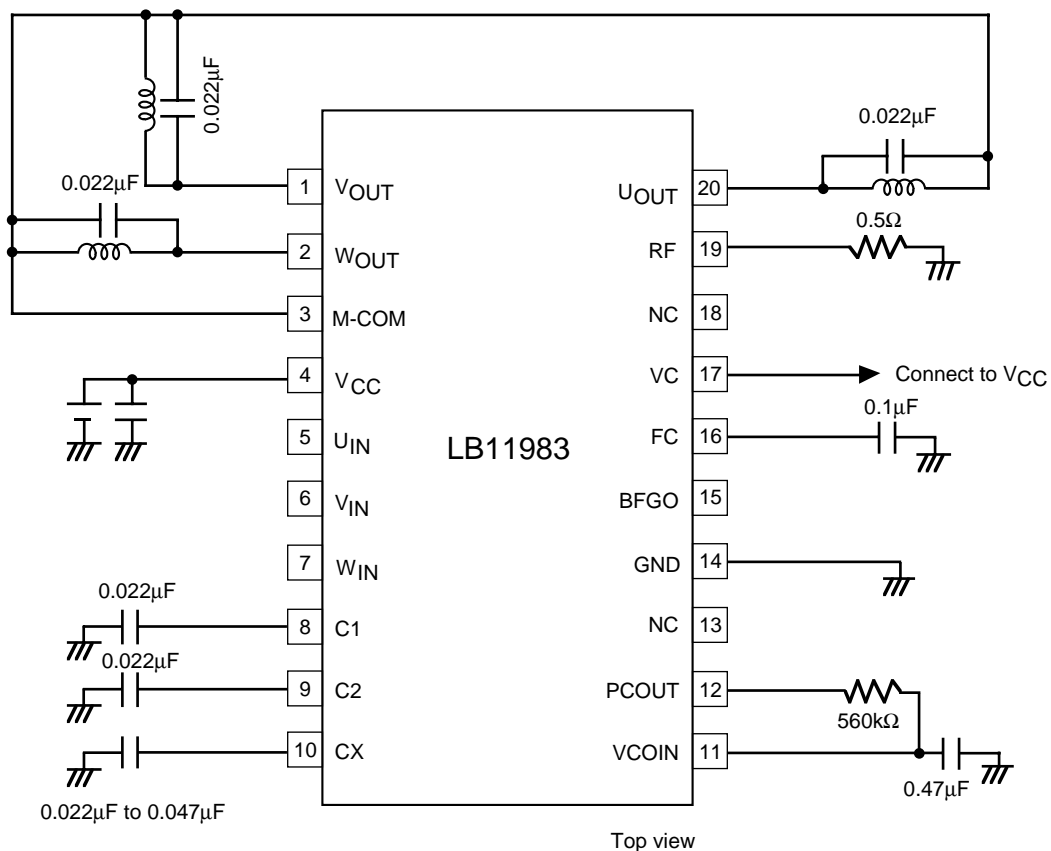

- Notes
1. Be sure to connect the VC pin to V_{CC} directly before use.
 2. For the constant of capacitor, etc., our value established through examination is given for reference. Adjust the value according to the motor to be used when considering this IC.
 3. If the output is not oscillated with the motor used, a capacitor inserted between output coil ends is not necessary.
 4. Pins 5 through 7 (U_{IN} , V_{IN} , and W_{IN}) are not to be used by a user. These are connected inside IC and should always be kept independent and open.
 5. NC pins (14 and 18) are not connected inside IC and can be used as relay pins.

- Specifications of any and all SANYO products described or contained herein stipulate the performance, characteristics, and functions of the described products in the independent state, and are not guarantees of the performance, characteristics, and functions of the described products as mounted in the customer's products or equipment. To verify symptoms and states that cannot be evaluated in an independent device, the customer should always evaluate and test devices mounted in the customer's products or equipment.
- SANYO Electric Co., Ltd. strives to supply high-quality high-reliability products. However, any and all semiconductor products fail with some probability. It is possible that these probabilistic failures could give rise to accidents or events that could endanger human lives, that could give rise to smoke or fire, or that could cause damage to other property. When designing equipment, adopt safety measures so that these kinds of accidents or events cannot occur. Such measures include but are not limited to protective circuits and error prevention circuits for safe design, redundant design, and structural design.
- In the event that any or all SANYO products (including technical data, services) described or contained herein are controlled under any of applicable local export control laws and regulations, such products must not be exported without obtaining the export license from the authorities concerned in accordance with the above law.
- No part of this publication may be reproduced or transmitted in any form or by any means, electronic or mechanical, including photocopying and recording, or any information storage or retrieval system, or otherwise, without the prior written permission of SANYO Electric Co., Ltd.
- Any and all information described or contained herein are subject to change without notice due to product/technology improvement, etc. When designing equipment, refer to the "Delivery Specification" for the SANYO product that you intend to use.
- Information (including circuit diagrams and circuit parameters) herein is for example only; it is not guaranteed for volume production. SANYO believes information herein is accurate and reliable, but no guarantees are made or implied regarding its use or any infringements of intellectual property rights or other rights of third parties.