

August 2000

# LM380

## 2.5W Audio Power Amplifier

### General Description

The LM380 is a power audio amplifier for consumer applications. In order to hold system cost to a minimum, gain is internally fixed at 34 dB. A unique input stage allows ground referenced input signals. The output automatically self-centers to one-half the supply voltage.

The output is short circuit proof with internal thermal limiting. The package outline is standard dual-in-line. The LM380N uses a copper lead frame. The center three pins on either side comprise a heat sink. This makes the device easy to use in standard PC layouts.

Uses include simple phonograph amplifiers, intercoms, line drivers, teaching machine outputs, alarms, ultrasonic drivers, TV sound systems, AM-FM radio, small servo drivers, power converters, etc.

A selected part for more power on higher supply voltages is available as the LM384. For more information see AN-69.

### Features

- Wide supply voltage range: 10V-22V
- Low quiescent power drain: 0.13W ( $V_S = 18V$ )
- Voltage gain fixed at 50
- High peak current capability: 1.3A
- Input referenced to GND
- High input impedance: 150k $\Omega$
- Low distortion
- Quiescent output voltage is at one-half of the supply voltage
- Standard dual-in-line package

### Connection Diagrams (Dual-In-Line Packages, Top View)

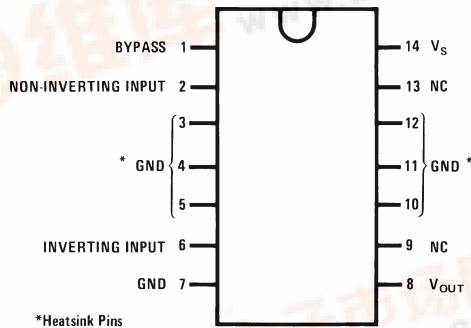

Order Number LM380N  
 See NS Package Number N14A

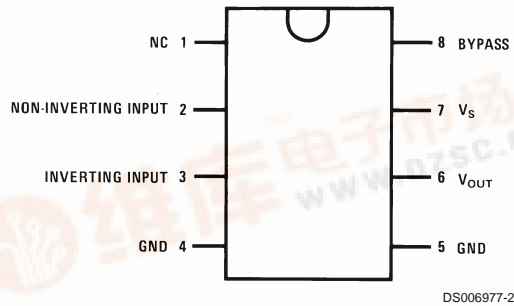

Order Number LM380N-8  
 See NS Package Number N08E



# Block and Schematic Diagrams

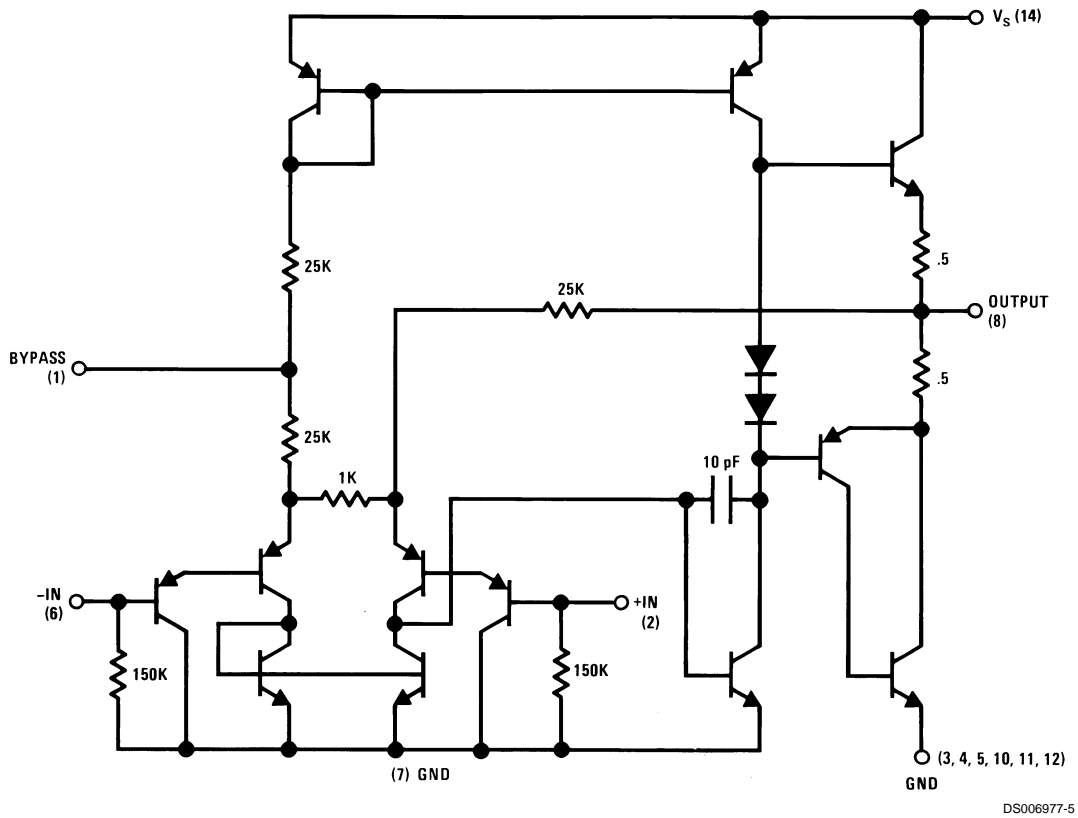
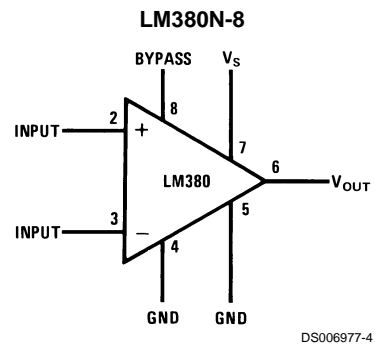
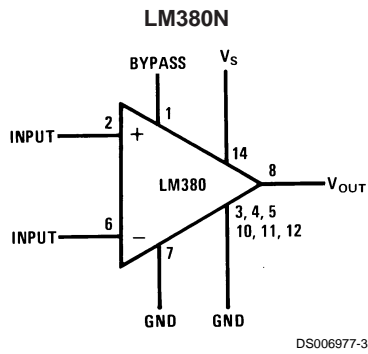

**Absolute Maximum Ratings** (Note 1)

If Military/Aerospace specified devices are required, please contact the National Semiconductor Sales Office/Distributors for availability and specifications.

Supply Voltage	22V
Peak Current	1.3A
Package Dissipation 14-Pin DIP (Note 7)	8.3W
Package Dissipation 8-Pin DIP (Note 7)	1.67W
Input Voltage	±0.5V
Storage Temperature	-65°C to +150°C

Operating Temperature	0°C to +70°C
Junction Temperature	+150°C
Lead Temperature (Soldering, 10 sec.)	+260°C
ESD rating to be determined	
Thermal Resistance	
$\theta_{JC}$ (14-Pin DIP)	30°C/W
$\theta_{JC}$ (8-Pin DIP)	37°C/W
$\theta_{JA}$ (14-Pin DIP)	79°C/W
$\theta_{JA}$ (8-Pin DIP)	107°C/W

**Electrical Characteristics** (Note 2)

Symbol	Parameter	Conditions	Min	Typ	Max	Units
$P_{OUT(RMS)}$	Output Power	$R_L = 8\Omega$ , THD = 3% (Notes 4, 5)	2.5			W
$A_V$	Gain		40	50	60	V/V
$V_{OUT}$	Output Voltage Swing	$R_L = 8\Omega$		14		$V_{p-p}$
$Z_{IN}$	Input Resistance			150k		$\Omega$
THD	Total Harmonic Distortion	(Notes 5, 6)		0.2		%
PSRR	Power Supply Rejection Ratio	(Note 3)		38		dB
$V_S$	Supply Voltage		10		22	V
BW	Bandwidth	$P_{OUT} = 2W$ , $R_L = 8\Omega$		100k		Hz
$I_Q$	Quiescent Supply Current			7	25	mA
$V_{OUTQ}$	Quiescent Output Voltage		8	9.0	10	V
$I_{BIAS}$	Bias Current	Inputs Floating		100		nA
$I_{SC}$	Short Circuit Current			1.3		A

**Note 1:** "Absolute Maximum Ratings" indicate limits beyond which damage to the device may occur. Operating Ratings indicate conditions for which the device is functional, but do not guarantee specific performance limits.

**Note 2:**  $V_S = 18V$  and  $T_A = 25^\circ C$  unless otherwise specified.

**Note 3:** Rejection ratio referred to the output with  $C_{BYPASS} = 5 \mu F$ .

**Note 4:** With device Pins 3, 4, 5, 10, 11, 12 soldered into a 1/16" epoxy glass board with 2 ounce copper foil with a minimum surface of 6 square inches.

**Note 5:**  $C_{BYPASS} = 0.47 \mu F$  on Pin 1.

**Note 6:** The maximum junction temperature of the LM380 is 150°C.

**Note 7:** The package is to be derated at 15°C/W junction to heat sink pins for 14-pin pkg; 75°C/W for 8-pin.

## Heat Sink Dimensions

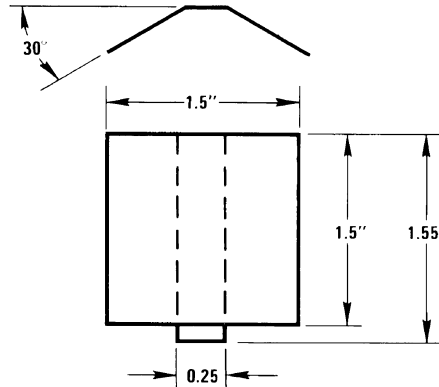

DS006977-6

Staver Heat Sink #V-7  
 Staver Company  
 41 Saxon Ave.  
 P.O. Drawer H  
 Bayshore, NY 11706  
 Tel: (516) 666-8000  
 Copper Wings  
 2 Required  
 Soldered to  
 Pins 3, 4, 5,  
 10, 11, 12  
 Thickness 0.04  
 Inches

## Typical Performance Characteristics

### Maximum Device Dissipation vs Ambient Temperature

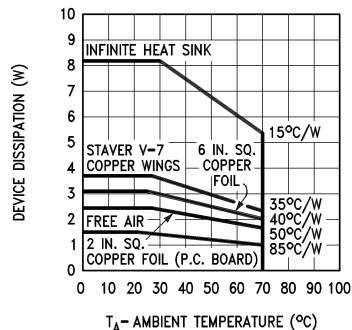

$T_A$  - AMBIENT TEMPERATURE ( $^{\circ}C$ )  
 Note: 2 oz. copper foil, single-sided PC board.  
 DS006977-12

### Device Dissipation vs Output Power — $4\Omega$ Load

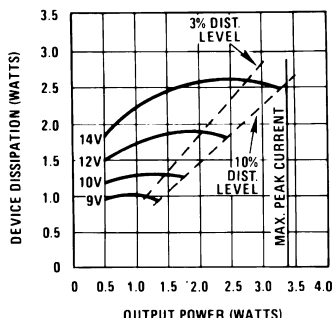

DS006977-13

### Device Dissipation vs Output Power — $8\Omega$ Load

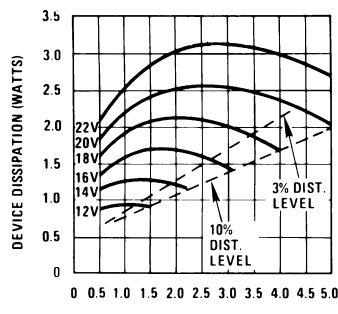

DS006977-14

### Device Dissipation vs Output Power — $16\Omega$ Load

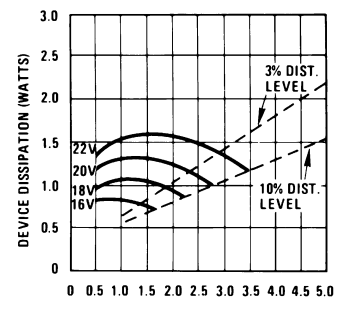

DS006977-15

## Typical Performance Characteristics (Continued)

**Power Supply Current vs Supply Voltage**

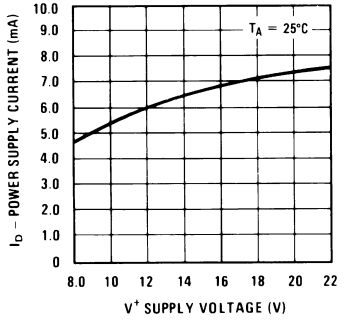

DS006977-16

**Total Harmonic Distortion vs Frequency**

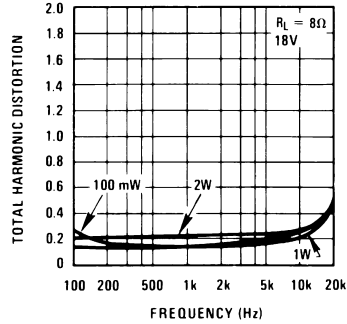

DS006977-17

**Output Voltage Gain and Phase vs Frequency**

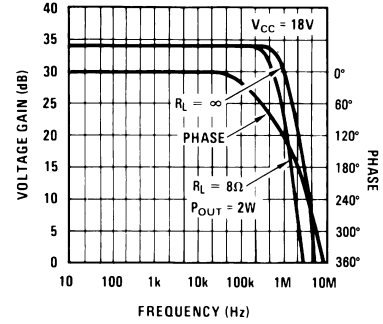

DS006977-18

**Total Harmonic Distortion vs Output Power**

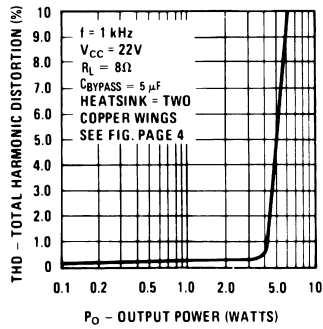

DS006977-19

**Device Dissipation vs Output Power**

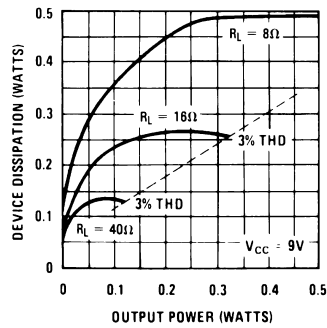

DS006977-20

**Supply Decoupling vs Frequency**

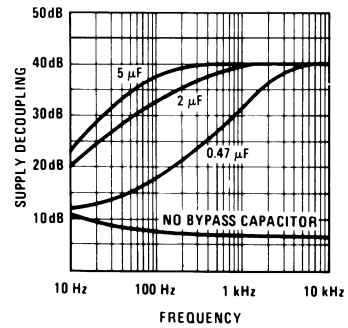

DS006977-21

## Typical Applications

**Phono Amplifier**

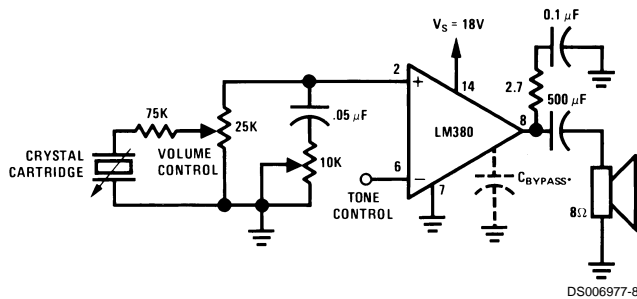

DS006977-8

# Typical Applications (Continued)

### Bridge Amplifier

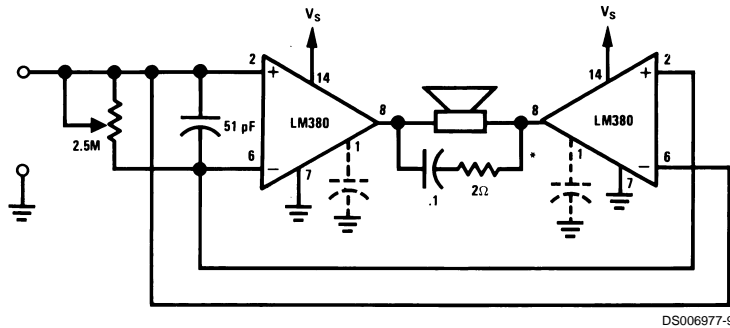

### Intercom

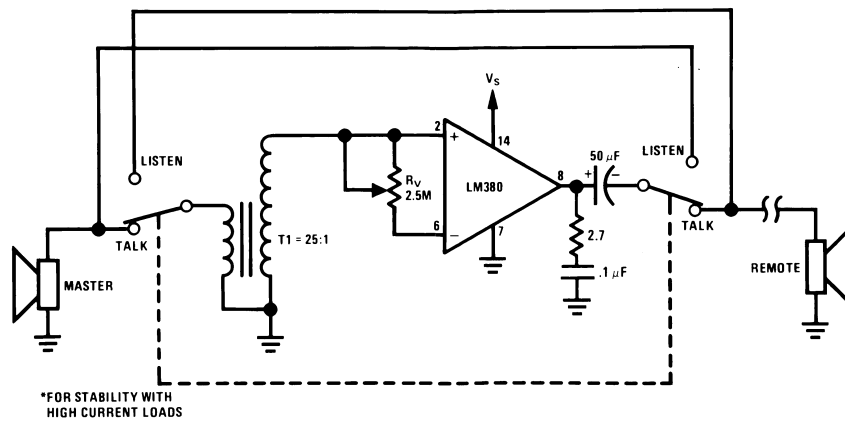

### Phase Shift Oscillator

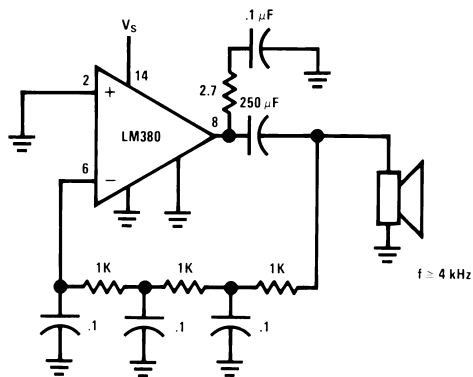

**Physical Dimensions** inches (millimeters) unless otherwise noted

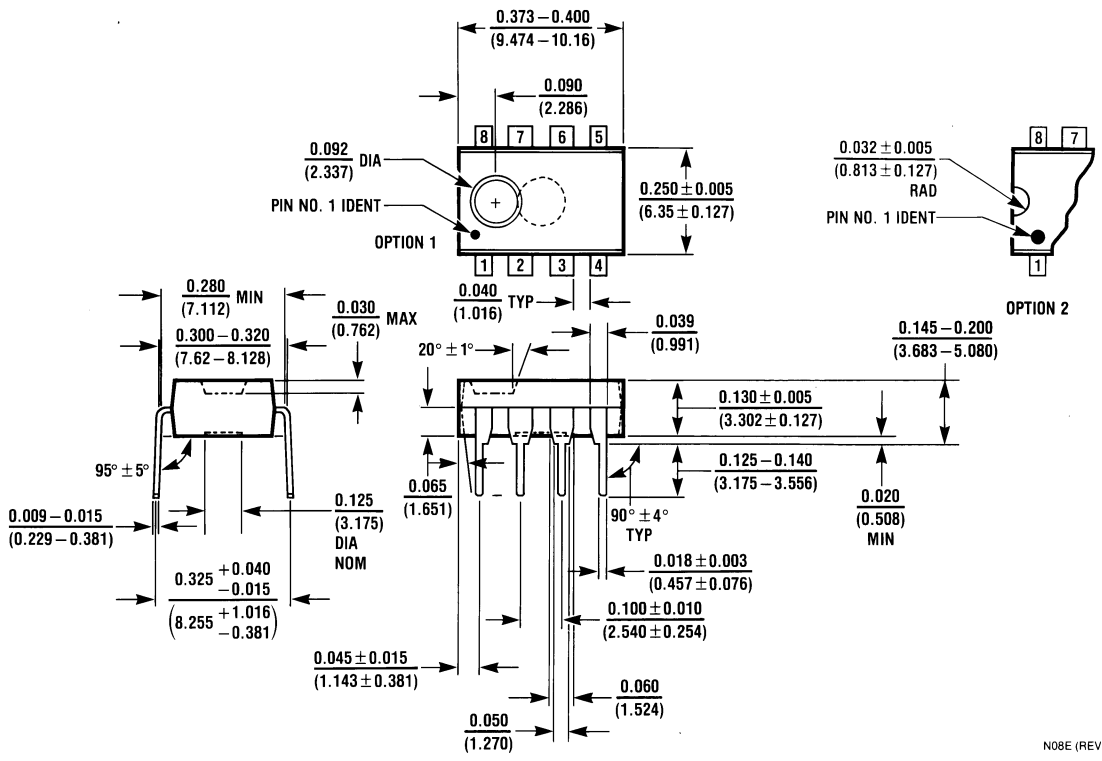

**Molded Dual-In-Line Package (N)**  
**Order Number LM380N-8**  
**NS Package Number N08E**

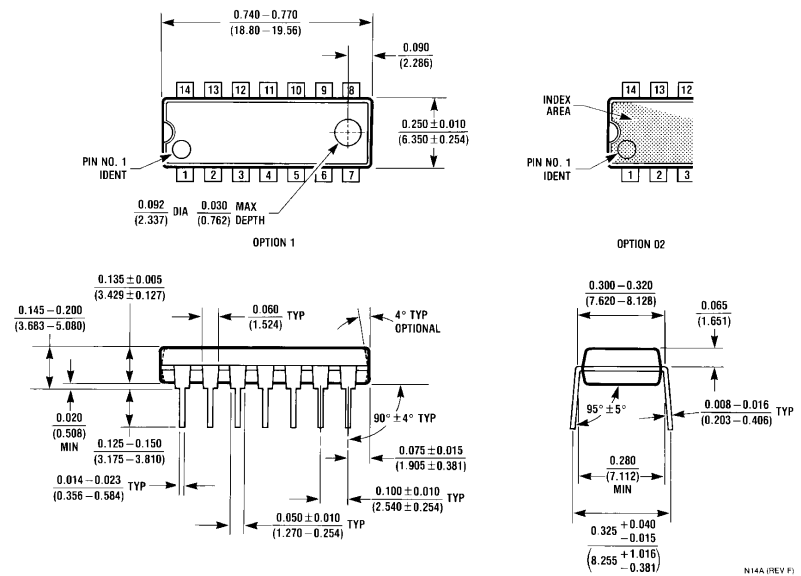

**Molded Dual-In-Line Package (N)**  
**Order Number LM380N**  
**NS Package Number N14A**

## Notes

### LIFE SUPPORT POLICY

NATIONAL'S PRODUCTS ARE NOT AUTHORIZED FOR USE AS CRITICAL COMPONENTS IN LIFE SUPPORT DEVICES OR SYSTEMS WITHOUT THE EXPRESS WRITTEN APPROVAL OF THE PRESIDENT AND GENERAL COUNSEL OF NATIONAL SEMICONDUCTOR CORPORATION. As used herein:

1. Life support devices or systems are devices or systems which, (a) are intended for surgical implant into the body, or (b) support or sustain life, and whose failure to perform when properly used in accordance with instructions for use provided in the labeling, can be reasonably expected to result in a significant injury to the user.
2. A critical component is any component of a life support device or system whose failure to perform can be reasonably expected to cause the failure of the life support device or system, or to affect its safety or effectiveness.



**National Semiconductor Corporation**

Americas  
Tel: 1-800-272-9959  
Fax: 1-800-737-7018  
Email: support@nsc.com

www.national.com

**National Semiconductor Europe**

Fax: +49 (0) 180-530 85 86  
Email: europe.support@nsc.com  
Deutsch Tel: +49 (0) 69 9508 6208  
English Tel: +44 (0) 870 24 0 2171  
Français Tel: +33 (0) 1 41 91 8790

**National Semiconductor Asia Pacific Customer Response Group**

Tel: 65-2544466  
Fax: 65-2504466  
Email: ap.support@nsc.com

**National Semiconductor Japan Ltd.**

Tel: 81-3-5639-7560  
Fax: 81-3-5639-7507