

MC145407

Advance Information

5 Volt Only Driver/Receiver

EIA-232-E and CCITT V.28

The MC145407 is a silicon-gate CMOS IC that combines three drivers and three receivers to fulfill the electrical specifications of EIA-232-E and CCITT V.28 while operating from a single + 5 V power supply. A voltage doubler and inverter convert the + 5 V to ± 10 V. This is accomplished through an on-board 20 kHz oscillator and four inexpensive external electrolytic capacitors. The three drivers and three receivers of the MC145407 are virtually identical to those of the MC145406. Therefore, for applications requiring more than three drivers and/or three receivers, an MC145406 can be powered from an MC145407, since the MC145407 charge pumps have been designed to guarantee ± 5 V at the output of up to six drivers. Thus, the MC145407 provides a high-performance, low-power, stand-alone solution or, with the MC145406, a + 5 V only, high-performance two-chip solution.

Drivers

- ± 7.5 V Output Swing
- 300 Ω Power-Off Impedance
- Output Current Limiting
- TTL and CMOS Compatible Inputs
- Slew Rate Range Limited from 4 V/ μ s to 30 V/ μ s

Receivers

- + 25 V Input Range
- 3 to 7 k Ω Input Impedance
- 0.8 V Hysteresis for Enhanced Noise Immunity

Charge Pumps

- + 5 V to ± 10 V Dual Charge Pump Architecture
- Supply Outputs Capable of Driving Three On-Chip Drivers and Three Drivers on the MC145406 Simultaneously
- Requires Four Inexpensive Electrolytic Capacitors
- On-Chip 20 kHz Oscillator

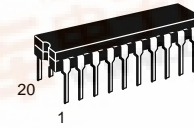

P SUFFIX
PLASTIC DIP
CASE 738

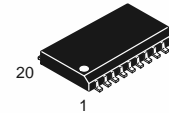

DW SUFFIX
SOG PACKAGE
CASE 751D

ORDERING INFORMATION

MC145407P	Plastic DIP
MC145407DW	SOG Package

PIN ASSIGNMENT

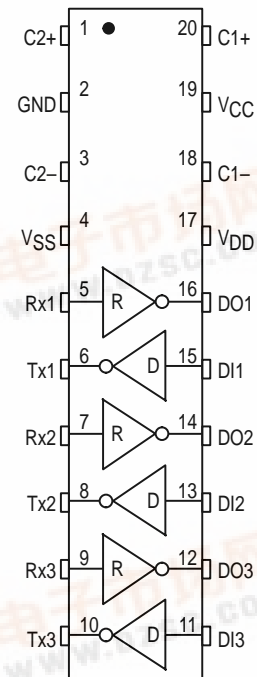

D = DRIVER
R = RECEIVER

FUNCTION DIAGRAM

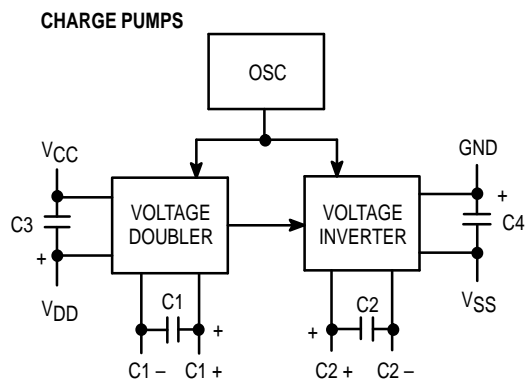

RECEIVER

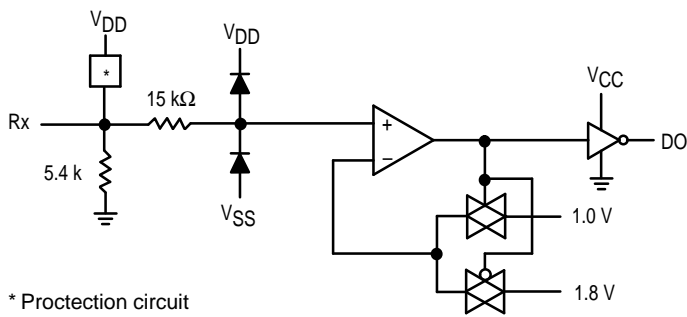

* Protection circuit

DRIVER

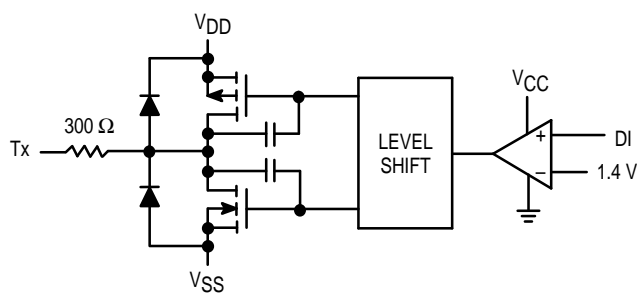

MAXIMUM RATINGS (Voltage polarities referenced to GND)

Rating	Symbol	Value	Unit
DC Supply Voltages	V_{CC}	- 0.5 to + 6.0	V
Input Voltage Range Rx1 – Rx3 Inputs DI1 – DI3 Inputs	V_{IR}	$V_{SS} - 15$ to $V_{DD} + 15$ - 0.5 to $(V_{CC} + 0.5)$	V
DC Current per Pin	I	± 100	mA
Power Dissipation	P_D	1	W
Operating Temperature Range	T_A	- 40 to + 85	°C
Storage Temperature Range	T_{stg}	- 85 to + 150	°C

This device contains protection circuitry to protect the inputs against damage due to high static voltages or electric fields; however, it is advised that normal precautions be taken to avoid application of any voltage higher than maximum rated voltages to this high impedance circuit. For proper operation, it is recommended that the voltages at the DI and DO pins be constrained to the range $GND \leq V_{DI} \leq V_{CC}$ and $GND \leq V_{DO} \leq V_{CC}$. Also, the voltage at the Rx pin should be constrained to $(V_{SS} - 15 V) \leq V_{Rx1} - Rx3 \leq (V_{DD} + 15 V)$, and Tx should be constrained to $V_{SS} \leq V_{Tx1} - Tx3 \leq V_{DD}$.

Unused inputs must always be tied to appropriate logic voltage level (e.g., GND or V_{CC} for DI, and GND for Rx).

DC ELECTRICAL CHARACTERISTICS (All polarities referenced to GND = 0 V; C1, C2, C3, C4 = 10 μ F; T_A = - 40 to + 85°C)

Parameter	Symbol	Min	Typ	Max	Unit	
DC Supply Voltage	V_{CC}	4.5	5	5.5	V	
Quiescent Supply Current (Outputs unloaded, inputs low)	I_{CC}	—	1.2	3.0	mA	
Output Voltage	$I_{load} = 0$ mA $I_{load} = 5$ mA $I_{load} = 10$ mA	V_{DD}	8.5	10	11	V
			7.5	9.5	—	
			6	9	—	
	V_{SS}	- 8.5	- 10	-11		
	$I_{load} = 0$ mA $I_{load} = 5$ mA $I_{load} = 10$ mA					

RECEIVER ELECTRICAL SPECIFICATIONS

(Voltage polarities referenced to GND = 0 V; $V_{CC} = + 5 V \pm 10\%$; C1, C2, C3, C4 = 10 μ F; T_A = - 40 to + 85°C)

Characteristic	Symbol	Min	Typ	Max	Unit
Input Turn-on Threshold $V_{DO1} - DO3 = V_{OL}$	Rx1 – Rx3 V_{on}	1.35	1.8	2.35	V
Input Turn-off Threshold $V_{DO1} - DO3 = V_{OH}$	Rx1 – Rx3 V_{off}	0.75	1.0	1.25	V
Input Threshold Hysteresis ($V_{on} - V_{off}$)	Rx1 – Rx3 V_{hys}	0.6	0.8	—	V
Input Resistance	Rx1 – Rx3 R_{in}	3.0	5.4	7.0	k Ω
High-Level Output Voltage $V_{Rx1} - Rx3 = - 3 V$ to - 25 V $I_{OH} = - 20 \mu A$ $I_{OH} = - 1 mA$	DO1 – DO3 V_{OH}	$V_{CC} - 0.1$ $V_{CC} - 0.7$	— 4.3	— —	V
Low-Level Output Voltage $V_{Rx1} - Rx3 = + 3 V$ to + 25 V $I_{OL} = + 20 \mu A$ $I_{OL} = + 1.6 mA$	DO1 – DO3 V_{OL}	— —	0.01 0.5	0.1 0.7	V

DRIVER ELECTRICAL SPECIFICATIONS

(Voltage polarities referenced to GND = 0 V: $V_{CC} = +5\text{ V} \pm 10\%$; C1, C2, C3, C4 = 10 μF ; $T_A = -40$ to $+85^\circ\text{C}$)

Characteristic	Symbol	Min	Typ	Max	Unit
Digital Input Voltage Logic 0 Logic 1	DI1 – DI3 V_{IL} V_{IH}	— 2.0	— —	0.8 —	V
Input Current $GND \leq V_{DI1} - DI3 \leq V_{CC}$	DI1 – DI3 I_{in}	—	—	± 1.0	μA
Output High Voltage $V_{DI1} - DI3 = \text{Logic 0}, R_L = 3.0\text{ k}\Omega$	Tx1 – Tx3 Tx1 – Tx6*	6 5	7.5 6.5	— —	V
Output Low Voltage $V_{DI1} - DI3 = \text{Logic 1}, R_L = 3.0\text{ k}\Omega$	Tx1 – Tx3 Tx1 – Tx6*	-6 -5	-7.5 -6.5	— —	V
Off Source Impedance (Figure 1)	Tx1 – Tx3 Z_{off}	300	—	—	Ω
Output Short-Circuit Current $V_{CC} = +5.5\text{ V}$	Tx1 – Tx3 Tx1 – Tx3 shorted to GND** Tx1 – Tx3 shorted to $\pm 15\text{ V}^{***}$	— —	— —	± 60 ± 100	mA

* Specifications for an MC145407 powering an MC145406 with three additional drivers/receivers.

** Specification is for one Tx output pin to be shorted at a time. Should all three driver outputs be shorted simultaneously, device power dissipation limits could be exceeded.

*** This condition could exceed package limitations.

SWITCHING CHARACTERISTICS ($V_{CC} = +5\text{ V} \pm 10\%$; C1, C2, C3, C4 = 10 μF ; $T_A = -40$ to $+85^\circ\text{C}$; See Figures 2 and 3)

Characteristic	Symbol	Min	Typ	Max	Unit
----------------	--------	-----	-----	-----	------

Drivers

Propagation Delay Time Low-to-High $R_L = 3\text{ k}\Omega, C_L = 50\text{ pF}$ or 2500 pF High-to-Low $R_L = 3\text{ k}\Omega, C_L = 50\text{ pF}$ or 2500 pF	Tx1 – Tx3 t_{PLH}	—	0.5	1	μs
	t_{PHL}	—	0.5	1	
Output Slew Rate Minimum Load: $R_L = 7\text{ k}\Omega, C_L = 0\text{ pF}$ Maximum Load: $R_L = 3\text{ k}\Omega, C_L = 2500\text{ pF}$	Tx1 – Tx3 SR	—	9.0	± 30	V/ μs
		4.0	—	—	

Receivers ($C_L = 50\text{ pF}$)

Propagation Delay Time Low-to-High High-to-Low	DO1 – DO3 t_{PLH}	—	—	1	μs
	t_{PHL}	—	—	1	
Output Rise Time	DO1 – DO3 t_r	—	250	400	ns
Output Fall Time	DO1 – DO3 t_f	—	40	100	ns

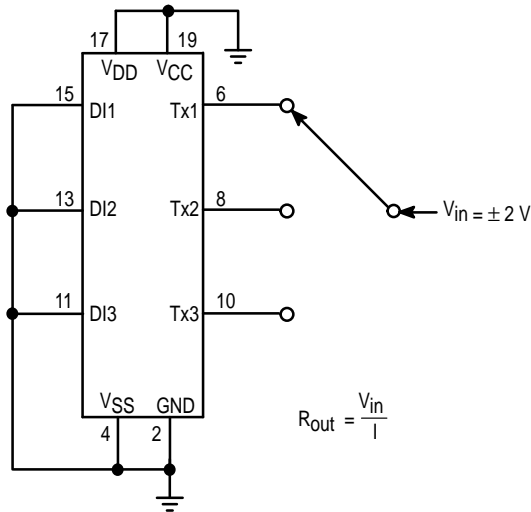

Figure 1. Power-Off Source Resistance

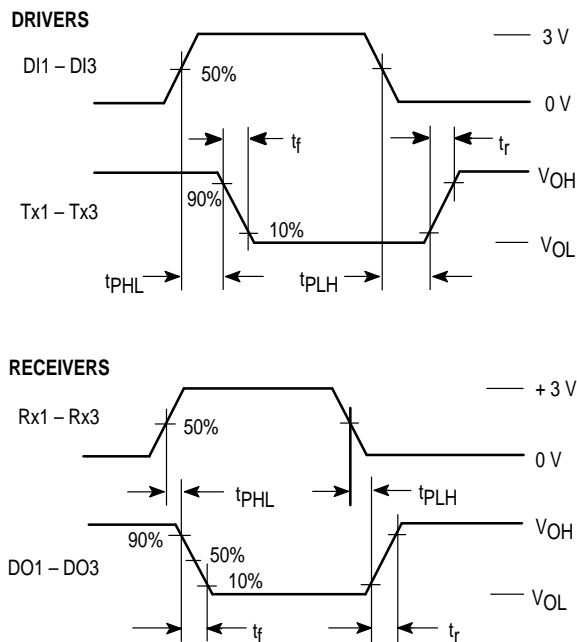

Figure 2. Switching Characteristics

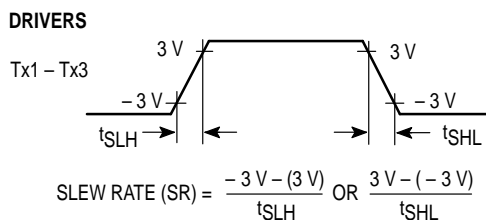

Figure 3. Slew Rate Characterization

PIN DESCRIPTIONS

VCC Digital Power Supply (Pin 19)

The digital supply pin, which is connected to the logic power supply. This pin should have a 0.33 μ F capacitor to ground.

GND Ground (Pin 2)

Ground return pin is typically connected to the signal ground pin of the EIA-232-E connector (Pin 7) as well as to the logic power supply ground.

VDD Positive Power Supply (Pin 17)

This is the positive output of the on-chip voltage doubler and the positive power supply input of the driver/receiver sections of the device. This pin requires an external storage capacitor to filter the 50% duty cycle voltage generated by the charge pump.

VSS Negative Power Supply (Pin 4)

This is the negative output of the on-chip voltage doubler/inverter and the negative power supply input of the driver/receiver sections of the device. This pin requires an external storage capacitor to filter the 50% duty cycle voltage generated by the charge pump.

C2+, C2-, C1-, C1+ Voltage Doubler and Inverter (Pins 1, 3, 18, 20)

These are the connections to the internal voltage doubler and inverter, which generate the VDD and VSS voltages.

Rx1, Rx2, Rx3 Receive Data Input (Pins 5, 7, 9)

These are the EIA-232-E receive signal inputs. A voltage between +3 and +25 V is decoded as a space and causes the corresponding DO pin to swing to ground (0 V). A voltage between -3 and -25 V is decoded as a mark, and causes the DO pin to swing up to VCC.

DO1, DO2, DO3 Data Output (Pins 16, 14, 12)

These are the receiver digital output pins, which swing from VCC to GND. Each output pin is capable of driving one LSTTL input load.

DI1, DI2, DI3 Data Input (Pins 15, 13, 11)

These are the high impedance digital input pins to the drivers. Input voltage levels on these pins must be between VCC and GND.

Tx1, Tx2, Tx3 Transmit Data Output (Pins 6, 8, 10)

These are the EIA-232-E transmit signal output pins, which swing toward VDD and VSS. A logic 1 at a DI input causes the corresponding Tx output to swing toward VSS. A logic 0 causes the output to swing toward VDD. The actual levels and slew rate achieved will depend on the output loading ($R_L \parallel C_L$).

APPLICATIONS INFORMATION

ESD CONSIDERATIONS

ESD protection on IC devices that have their pins accessible to the outside world is essential. High static voltages applied to the pins when someone touches them either directly or indirectly can cause damage to gate oxides and transistor junctions by coupling a portion of the energy from the I/O pin to the power supply busses of the IC. This coupling will usually occur through the internal ESD protection diodes. The key to protecting the IC is to shunt as much of the energy to ground as possible before it enters the IC. Figure 7 shows a technique which will clamp the ESD voltage at approximately + 15 V using the MMBZ15VDLT1. Any residual voltage which appears on the supply pins is shunted to ground through the 0.1 μF capacitors.

OPERATION WITH SMALLER VALUE CHARGE PUMP CAPS

The MC145407 is characterized in the electrical tables

using 10 μF charge pump caps to illustrate its capability in driving a companion MC145406 or MC145403. If there is no requirement to support a second interface device and/or the charge pump is not being used to power any other components, the MC145407 is capable of complying with EIA-232-E and V.28 with smaller value charge pump caps. Table 1 summarizes driver performance with both 2.2 μF and 1.0 μF charge pump caps.

Table 1. Typical Performance

Parameter	2.2 μF	1.0 μF
Tx V_{OH} @ 25°C	7.3	7.2
Tx V_{OH} @ 85°C	7.2	7.1
Tx V_{OL} @ 25°C	-6.5	-6.4
Tx V_{OL} @ 85°C	-6.1	-6.0
Tx Slew Rate @ 25°C	8.0 V/ μs	8.0 V/ μs
Tx Slew Rate @ 85°C	7.0 V/ μs	7.0 V/ μs

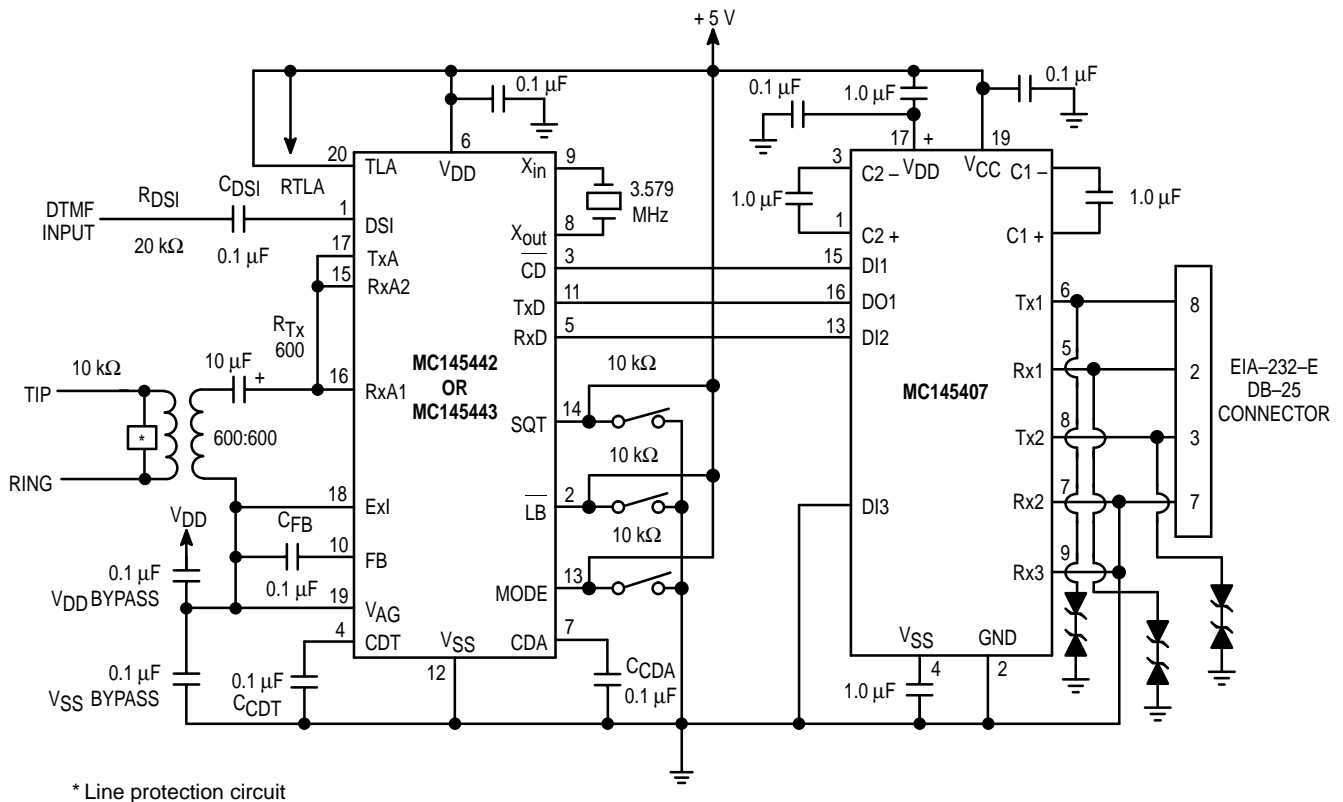

Figure 4. 5 V, 300 Baud Modem with EIA-232-E Interface

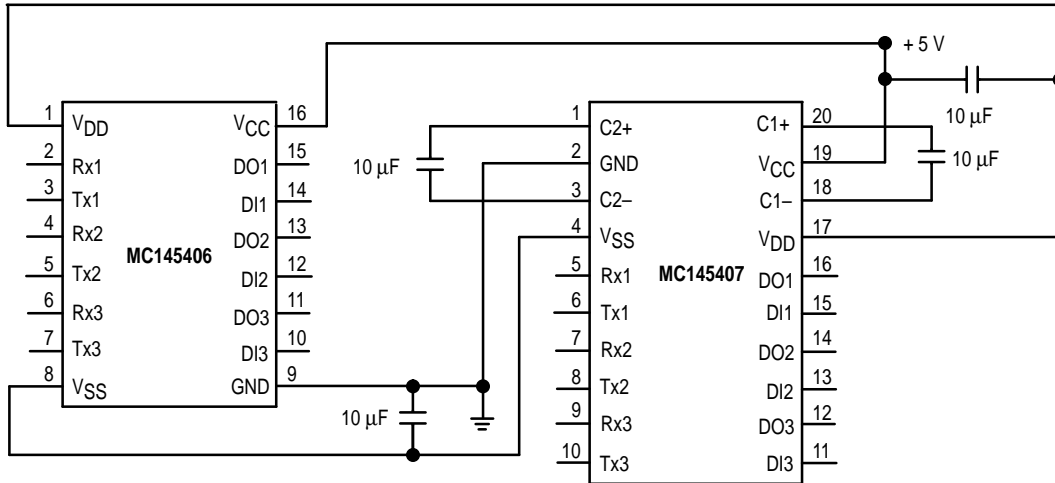

Figure 5. MC145406/MC145407 5 V Only Solution for up to Six EIA-232-E Drivers and Receivers

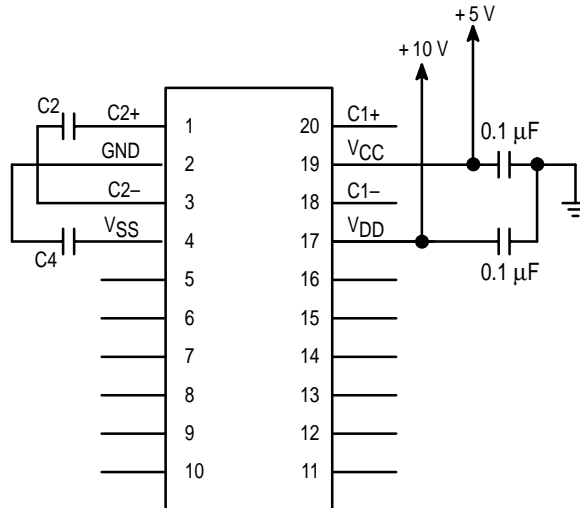

Figure 6. Two Supply Configuration (MC145407 Generates VSS Only)

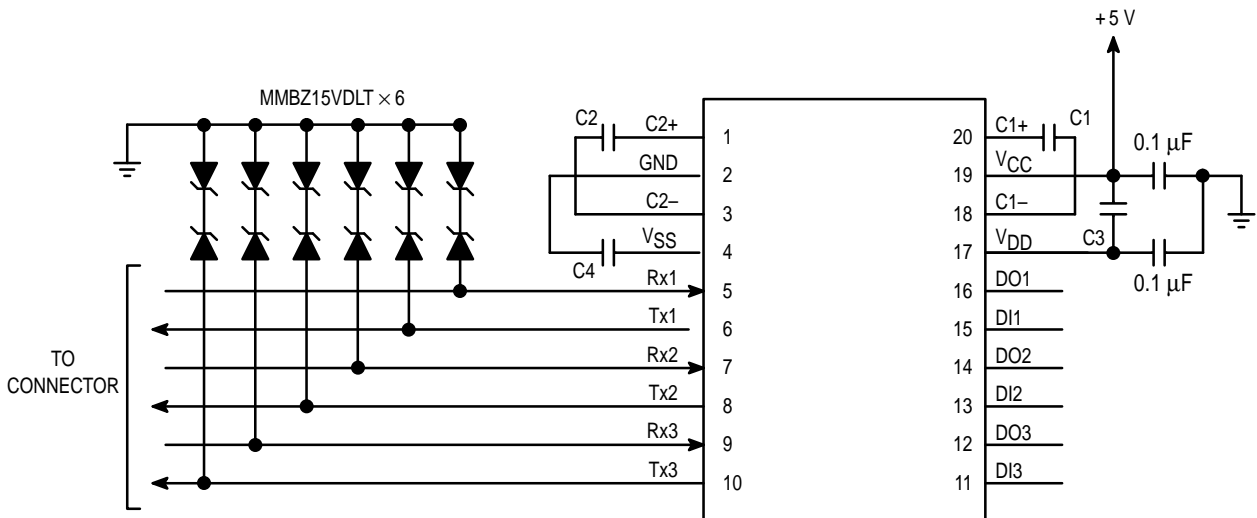
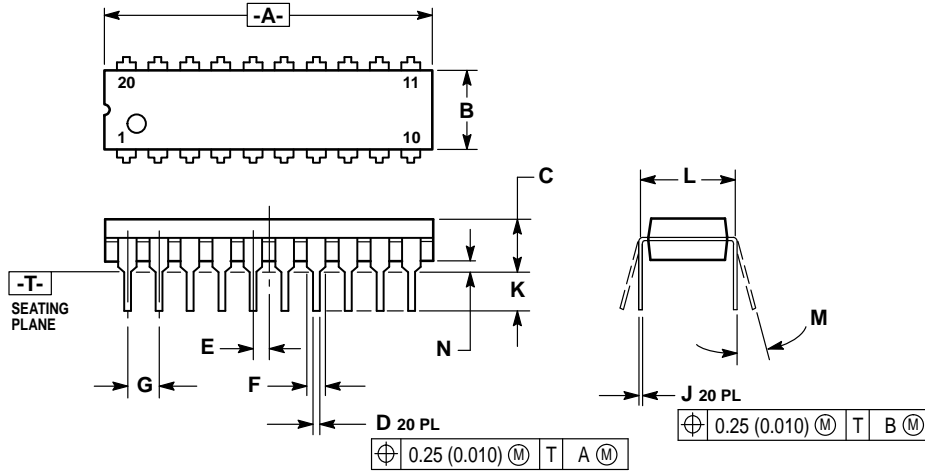

Figure 7. ESD Protection Scheme

PACKAGE DIMENSIONS

P SUFFIX PLASTIC DIP CASE 738-03



NOTES:

1. DIMENSIONING AND TOLERANCING PER ANSI Y14.5M, 1982.
2. CONTROLLING DIMENSION: INCH.
3. DIMENSION L TO CENTER OF LEAD WHEN FORMED PARALLEL.
4. DIMENSION B DOES NOT INCLUDE MOLD FLASH.

DIM	INCHES		MILLIMETERS	
	MIN	MAX	MIN	MAX
A	1.010	1.070	25.66	27.17
B	0.240	0.260	6.10	6.60
C	0.150	0.180	3.81	4.57
D	0.015	0.022	0.39	0.55
E	0.050 BSC		1.27 BSC	
F	0.050	0.070	1.27	1.77
G	0.100 BSC		2.54 BSC	
J	0.008	0.015	0.21	0.38
K	0.110	0.140	2.80	3.55
L	0.300 BSC		7.62 BSC	
M	0°	15°	0°	15°
N	0.020	0.040	0.51	1.01

DW SUFFIX SOG PACKAGE CASE 751D-04

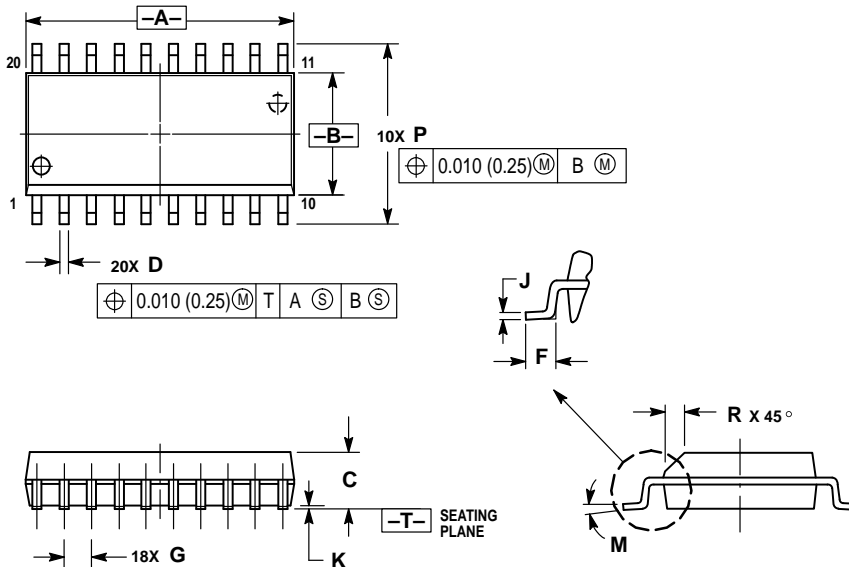

NOTES:

1. DIMENSIONING AND TOLERANCING PER ANSI Y14.5M, 1982.
2. CONTROLLING DIMENSION: MILLIMETER.
3. DIMENSIONS A AND B DO NOT INCLUDE MOLD PROTRUSION.
4. MAXIMUM MOLD PROTRUSION 0.150 (0.006) PER SIDE.
5. DIMENSION D DOES NOT INCLUDE DAMBAR PROTRUSION. ALLOWABLE DAMBAR PROTRUSION SHALL BE 0.13 (0.005) TOTAL IN EXCESS OF D DIMENSION AT MAXIMUM MATERIAL CONDITION.

DIM	MILLIMETERS		INCHES	
	MIN	MAX	MIN	MAX
A	12.65	12.95	0.499	0.510
B	7.40	7.60	0.292	0.299
C	2.35	2.65	0.093	0.104
D	0.35	0.49	0.014	0.019
F	0.50	0.90	0.020	0.035
G	1.27 BSC		0.050 BSC	
J	0.25	0.32	0.010	0.012
K	0.10	0.25	0.004	0.009
M	0°	7°	0°	7°
P	10.05	10.55	0.395	0.415
R	0.25	0.75	0.010	0.029

Motorola reserves the right to make changes without further notice to any products herein. Motorola makes no warranty, representation or guarantee regarding the suitability of its products for any particular purpose, nor does Motorola assume any liability arising out of the application or use of any product or circuit, and specifically disclaims any and all liability, including without limitation consequential or incidental damages. "Typical" parameters can and do vary in different applications. All operating parameters, including "Typicals" must be validated for each customer application by customer's technical experts. Motorola does not convey any license under its patent rights nor the rights of others. Motorola products are not designed, intended, or authorized for use as components in systems intended for surgical implant into the body, or other applications intended to support or sustain life, or for any other application in which the failure of the Motorola product could create a situation where personal injury or death may occur. Should Buyer purchase or use Motorola products for any such unintended or unauthorized application, Buyer shall indemnify and hold Motorola and its officers, employees, subsidiaries, affiliates, and distributors harmless against all claims, costs, damages, and expenses, and reasonable attorney fees arising out of, directly or indirectly, any claim of personal injury or death associated with such unintended or unauthorized use, even if such claim alleges that Motorola was negligent regarding the design or manufacture of the part. Motorola and  are registered trademarks of Motorola, Inc. Motorola, Inc. is an Equal Opportunity/Affirmative Action Employer.

How to reach us:

USA/EUROPE: Motorola Literature Distribution;
P.O. Box 20912; Phoenix, Arizona 85036. 1-800-441-2447

JAPAN: Nippon Motorola Ltd.; Tatsumi-SPD-JLDC, Toshikatsu Otsuki,
6F Seibu-Butsuryu-Center, 3-14-2 Tatsumi Koto-Ku, Tokyo 135, Japan. 03-3521-8315

HONG KONG: Motorola Semiconductors H.K. Ltd.; 8B Tai Ping Industrial Park,
151 Ting Kok Road, Tai Po, N.T., Hong Kong. 852-26629298