

Integrated Silicon Pressure Sensor for Manifold Absolute Pressure Applications

On-Chip Signal Conditioned, Temperature Compensated and Calibrated

**MPX4100A
MPXA4100A
SERIES**

**INTEGRATED
PRESSURE SENSOR
15 to 115 kPa (2.2 to 16.7 psi)
0.2 to 4.8 Volts Output**

The Motorola MPX4100A/MPXA4100A series Manifold Absolute Pressure (MAP) sensor for engine control is designed to sense absolute air pressure within the intake manifold. This measurement can be used to compute the amount of fuel required for each cylinder. The small form factor and high reliability of on-chip integration makes the Motorola MAP sensor a logical and economical choice for automotive system designers.

The MPX4100A/MPXA4100A series piezoresistive transducer is a state-of-the-art, monolithic, signal conditioned, silicon pressure sensor. This sensor combines advanced micromachining techniques, thin film metallization, and bipolar semiconductor processing to provide an accurate, high level analog output signal that is proportional to applied pressure.

Figure 1 shows a block diagram of the internal circuitry integrated on a pressure sensor chip.

Features

- 1.8% Maximum Error Over 0° to 85°C
- Specifically Designed for Intake Manifold Absolute Pressure Sensing in Engine Control Systems
- Temperature Compensated Over -40°C to +125°C
- Durable Epoxy Unibody Element or Thermoplastic (PPS) Surface Mount Package

Application Examples

- Manifold Sensing for Automotive Systems
- Ideally suited for Microprocessor or Microcontroller-Based Systems
- Also Ideal for Non-Automotive Applications

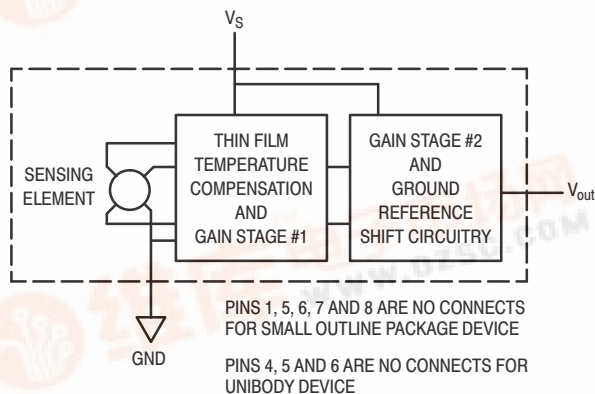
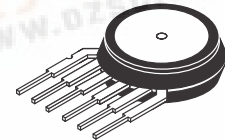
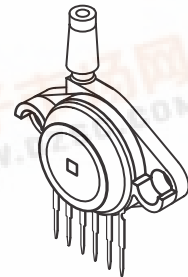

Figure 1. Fully Integrated Pressure Sensor Schematic

UNIBODY PACKAGE



MPX4100A
CASE 867



MPX4100AP
CASE 867B

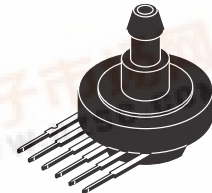

MPX4100AS
CASE 867E

SMALL OUTLINE PACKAGE

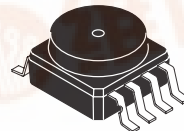

MPXA4100A6U
CASE 482

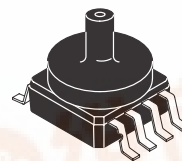

MPXA4100AC6U
CASE 482A

PIN NUMBER			
1	N/C	5	N/C
2	V _S	6	N/C
3	Gnd	7	N/C
4	V _{out}	8	N/C

NOTE: Pins 1, 5, 6, 7, and 8 are internal device connections. Do not connect to external circuitry or ground. Pin 1 is noted by the notch in the lead.

PIN NUMBER			
1	V _{out}	4	N/C
2	Gnd	5	N/C
3	V _S	6	N/C

NOTE: Pins 4, 5, and 6 are internal device connections. Do not connect to external circuitry or ground. Pin 1 is noted by the notch in the lead.



MPX4100A MPXA4100A SERIES

MAXIMUM RATINGS(NOTE)

Parametrics	Symbol	Value	Units
Maximum Pressure (P1 > P2)	P_{max}	400	kPa
Storage Temperature	T_{stg}	-40° to +125°	°C
Operating Temperature	T_A	-40° to +125°	°C

NOTE: Exposure beyond the specified limits may cause permanent damage or degradation to the device.

OPERATING CHARACTERISTICS ($V_S = 5.1$ Vdc, $T_A = 25^\circ\text{C}$ unless otherwise noted, P1 > P2. Decoupling circuit shown in Figure 3 required to meet electrical specifications.)

Characteristic	Symbol	Min	Typ	Max	Unit
Pressure Range ⁽¹⁾	P_{OP}	20	—	105	kPa
Supply Voltage ⁽²⁾	V_S	4.85	5.1	5.35	Vdc
Supply Current	I_o	—	7.0	10	mAdc
Minimum Pressure Offset ⁽³⁾ @ $V_S = 5.1$ Volts (0 to 85°C)	V_{off}	0.225	0.306	0.388	Vdc
Full Scale Output ⁽⁴⁾ @ $V_S = 5.1$ Volts (0 to 85°C)	V_{FSSO}	4.870	4.951	5.032	Vdc
Full Scale Span ⁽⁵⁾ @ $V_S = 5.1$ Volts (0 to 85°C)	V_{FSS}	—	4.59	—	Vdc
Accuracy ⁽⁶⁾ (0 to 85°C)	—	—	—	±1.8	% V_{FSS}
Sensitivity	V/P	—	54	—	mV/kPa
Response Time ⁽⁷⁾	t_R	—	1.0	—	ms
Output Source Current at Full Scale Output	I_{o+}	—	0.1	—	mAdc
Warm-Up Time ⁽⁸⁾	—	—	20	—	ms
Offset Stability ⁽⁹⁾	—	—	±0.5	—	% V_{FSS}

NOTES:

- 1.0 kPa (kiloPascal) equals 0.145 psi.
- Device is ratiometric within this specified excitation range.
- Offset (V_{off}) is defined as the output voltage at the minimum rated pressure.
- Full Scale Output (V_{FSSO}) is defined as the output voltage at the maximum or full rated pressure.
- Full Scale Span (V_{FSS}) is defined as the algebraic difference between the output voltage at full rated pressure and the output voltage at the minimum rated pressure.
- Accuracy (error budget) consists of the following:
 - Linearity: Output deviation from a straight line relationship with pressure over the specified pressure range.
 - Temperature Hysteresis: Output deviation at any temperature within the operating temperature range, after the temperature is cycled to and from the minimum or maximum operating temperature points, with zero differential pressure applied.
 - Pressure Hysteresis: Output deviation at any pressure within the specified range, when this pressure is cycled to and from the minimum or maximum rated pressure, at 25°C.
 - TcSpan: Output deviation over the temperature range of 0 to 85°C, relative to 25°C.
 - TcOffset: Output deviation with minimum rated pressure applied, over the temperature range of 0 to 85°C, relative to 25°C.
 - Variation from Nominal: The variation from nominal values, for Offset or Full Scale Span, as a percent of V_{FSS} , at 25°C.
- Response Time is defined as the time for the incremental change in the output to go from 10% to 90% of its final value when subjected to a specified step change in pressure.
- Warm-up Time is defined as the time required for the product to meet the specified output voltage after the Pressure has been stabilized.
- Offset Stability is the product's output deviation when subjected to 1000 hours of Pulsed Pressure, Temperature Cycling with Bias Test.

MECHANICAL CHARACTERISTICS

Characteristics	Typ	Unit
Weight, Basic Element (Case 867)	4.0	grams
Weight, Small Outline Package (Case 482)	1.5	grams

MPX4100A MPXA4100A SERIES

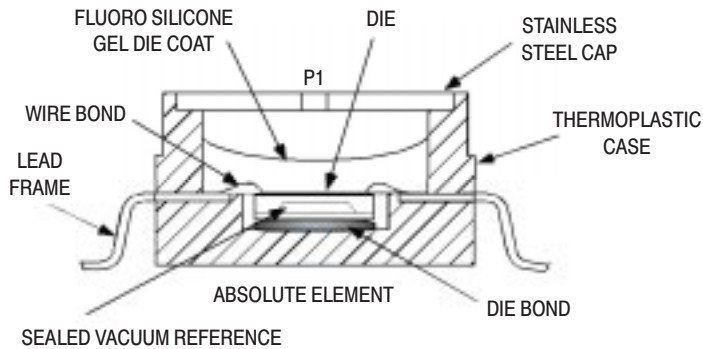
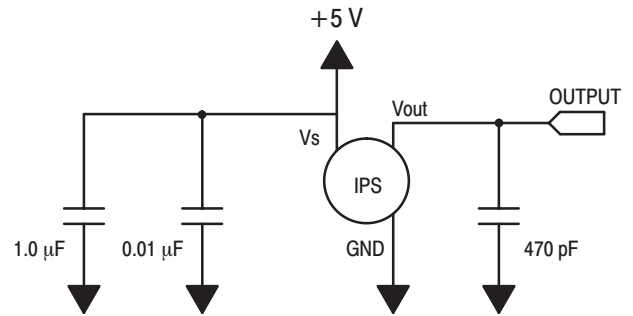

Figure 2. Cross Sectional Diagram SOP (not to scale)

Figure 2 illustrates the absolute sensing chip in the basic chip carrier (Case 482).



**Figure 3. Recommended power supply decoupling and output filtering.
For additional output filtering, please refer to Application Note AN1646.**

Figure 3 shows the recommended decoupling circuit for interfacing the output of the integrated sensor to the A/D input of a microprocessor or microcontroller. Proper decoupling of the power supply is recommended.

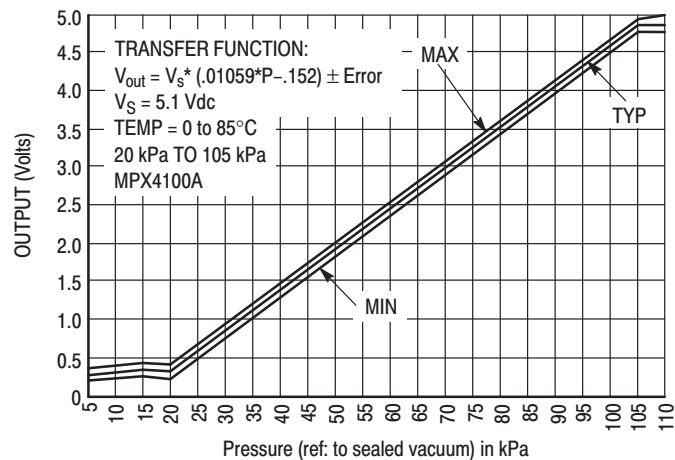

Figure 4. Output versus Absolute Pressure

Figure 4 shows the sensor output signal relative to pressure input. Typical, minimum, and maximum output curves are shown for operation over a temperature range of 0° to 85°C. The output will saturate outside of the specified pressure range.

A fluorosilicone gel isolates the die surface and wire bonds from the environment, while allowing the pressure signal to be transmitted to the sensor diaphragm. The

MPX4100A/MPXA4100A series pressure sensor operating characteristics, and internal reliability and qualification tests are based on use of dry air as the pressure media. Media, other than dry air, may have adverse effects on sensor performance and long-term reliability. Contact the factory for information regarding media compatibility in your application.

MPX4100A MPXA4100A SERIES

Transfer Function (MPX4100A, MPXA4100A)

Nominal Transfer Value: $V_{out} = V_S (P \times 0.01059 - 0.1518)$
 $\pm (\text{Pressure Error} \times \text{Temp. Factor} \times 0.01059 \times V_S)$
 $V_S = 5.1 \text{ V} \pm 0.25 \text{ Vdc}$

Temperature Error Band

MPX4100A, MPXA4100A Series

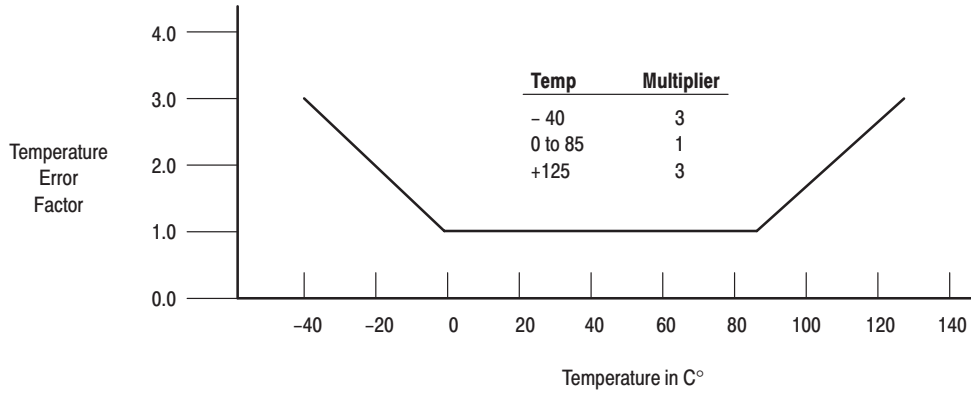

NOTE: The Temperature Multiplier is a linear response from 0°C to -40°C and from 85°C to 125°C.

Pressure Error Band

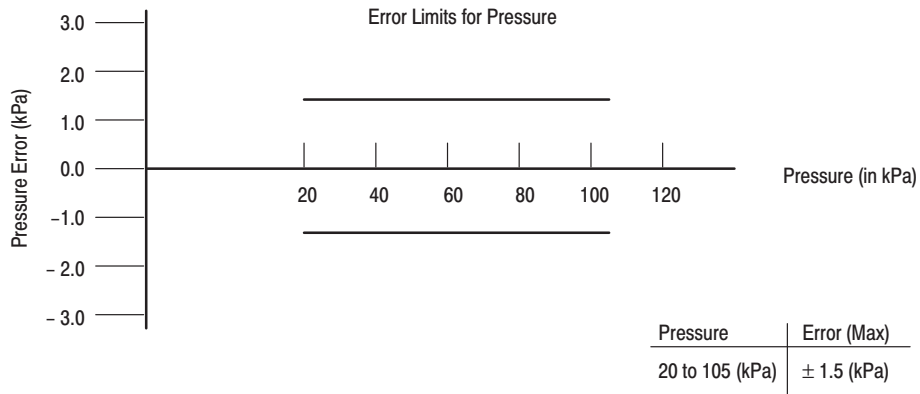

MPX4100A MPXA4100A SERIES

PRESSURE (P1)/VACUUM (P2) SIDE IDENTIFICATION TABLE

Motorola designates the two sides of the pressure sensor as the Pressure (P1) side and the Vacuum (P2) side. The Pressure (P1) side is the side containing fluorosilicone gel which protects the die from harsh media. The Motorola MPX

pressure sensor is designed to operate with positive differential pressure applied, $P1 > P2$.

The Pressure (P1) side may be identified by using the table below:

Part Number	Case Type	Pressure (P1) Side Identifier
MPX4100A	867	Stainless Steel Cap
MPX4100AP	867B	Side with Port Marking
MPX4100AS	867E	Side with Port Attached
MPXA4100A6U/T1	482	Stainless Steel Cap
MPXA4100AC6U	482A	Side with Port Attached

ORDERING INFORMATION — UNIBODY PACKAGE

Device Type	Options	Case Type	MPX Series	
			Order Number	Device Marking
Basic Element	Absolute, Element Only	867	MPX4100A	MPX4100A
Ported Elements	Absolute, Ported	867B	MPX4100AP	MPX4100AP
	Absolute, Stove Pipe Port	867E	MPX4100AS	MPX4100A

ORDERING INFORMATION — SMALL OUTLINE PACKAGE

Device Type	Options	Case No.	MPX Series Order No.	Packing Options	Marking
Basic Element	Absolute, Element Only	482	MPXA4100A6U	Rails	MPXA4100A
	Absolute, Element Only	482	MPXA4100A6T1	Tape and Reel	MPXA4100A
Ported Element	Absolute, Axial Port	482A	MPXA4100AC6U	Rails	MPXA4100A

MPX4100A MPXA4100A SERIES

INFORMATION FOR USING THE SMALL OUTLINE PACKAGE (CASE 482)

MINIMUM RECOMMENDED FOOTPRINT FOR SURFACE MOUNTED APPLICATIONS

Surface mount board layout is a critical portion of the total design. The footprint for the surface mount packages must be the correct size to ensure proper solder connection interface between the board and the package. With the correct

footprint, the packages will self align when subjected to a solder reflow process. It is always recommended to design boards with a solder mask layer to avoid bridging and shorting between solder pads.

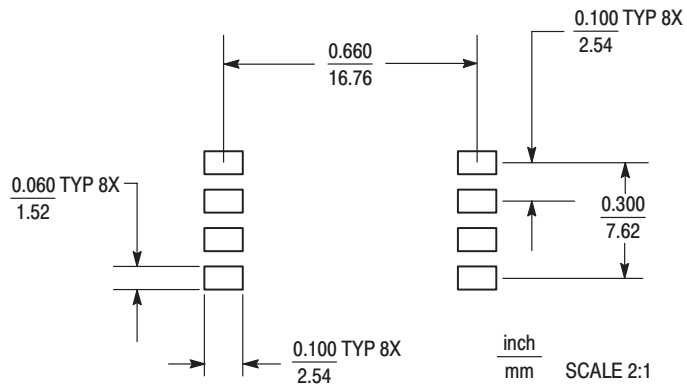
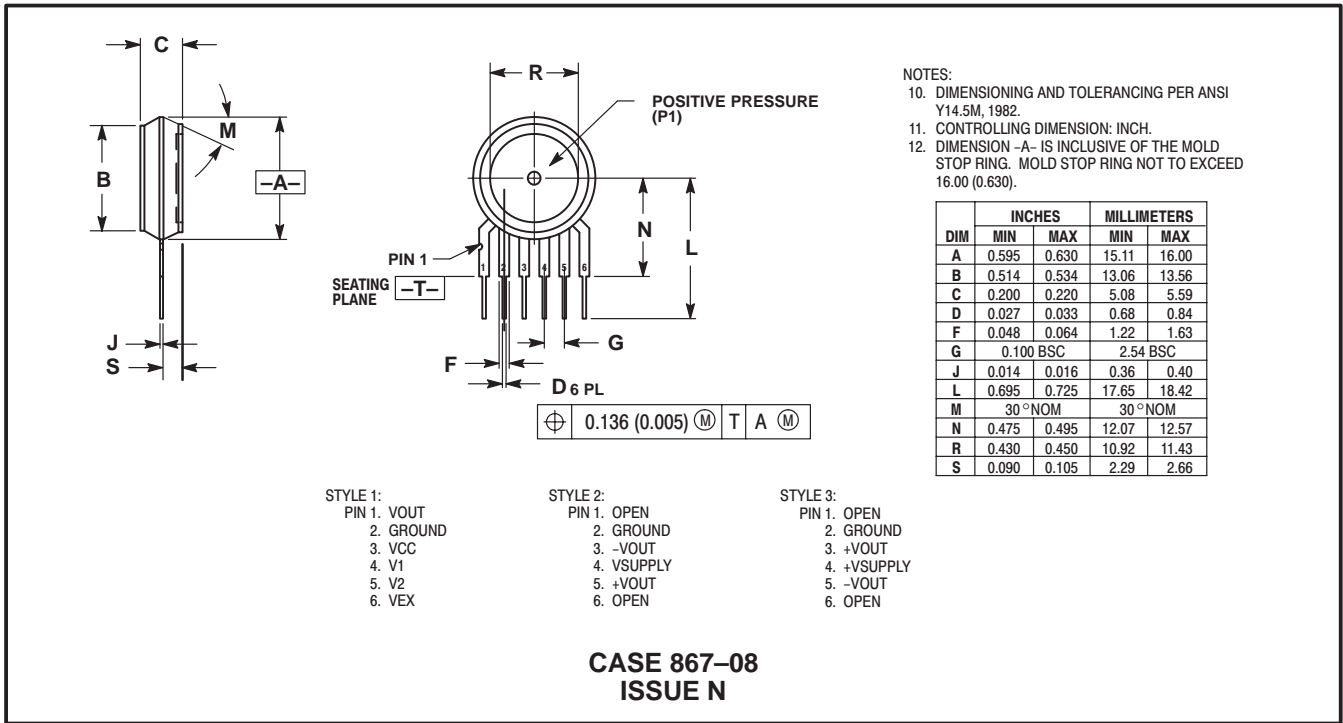

Figure 5. SOP Footprint (Case 482)

MPX4100A MPXA4100A SERIES

UNIBODY PACKAGE DIMENSIONS



BASIC ELEMENT

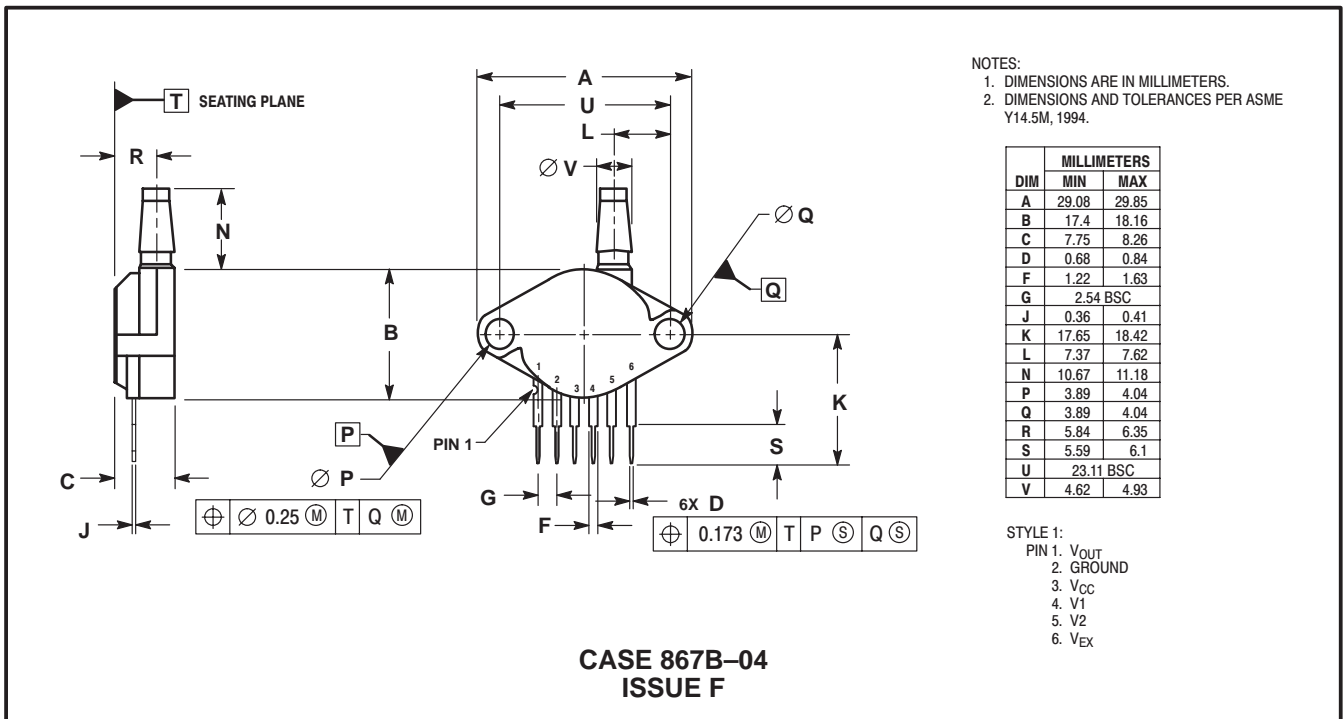

PRESSURE SIDE PORTED (AP, GP)

MPX4100A MPXA4100A SERIES

UNIBODY PACKAGE DIMENSIONS—CONTINUED

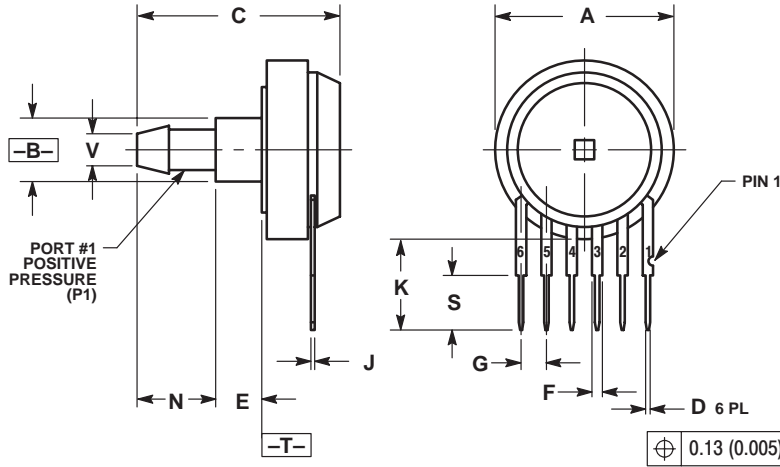

- NOTES:
 1. DIMENSIONING AND TOLERANCING PER ANSI Y14.5M, 1982.
 2. CONTROLLING DIMENSION: INCH.

DIM	INCHES		MILLIMETERS	
	MIN	MAX	MIN	MAX
A	0.690	0.720	17.53	18.28
B	0.245	0.255	6.22	6.48
C	0.780	0.820	19.81	20.82
D	0.027	0.033	0.69	0.84
E	0.178	0.186	4.52	4.72
F	0.048	0.064	1.22	1.63
G	0.100	BSC	2.54	BSC
J	0.014	0.016	0.36	0.41
K	0.345	0.375	8.76	9.53
N	0.300	0.310	7.62	7.87
S	0.220	0.240	5.59	6.10
V	0.182	0.194	4.62	4.93

- STYLE 1:
 PIN 1: V_{OUT}
 2. GROUND
 3. V_{CC}
 4. V₁
 5. V₂
 6. V_{EX}

**CASE 867E-03
 ISSUE D**

PRESSURE SIDE PORTED (AS, GS)

MPX4100A MPXA4100A SERIES

SMALL OUTLINE PACKAGE DIMENSIONS

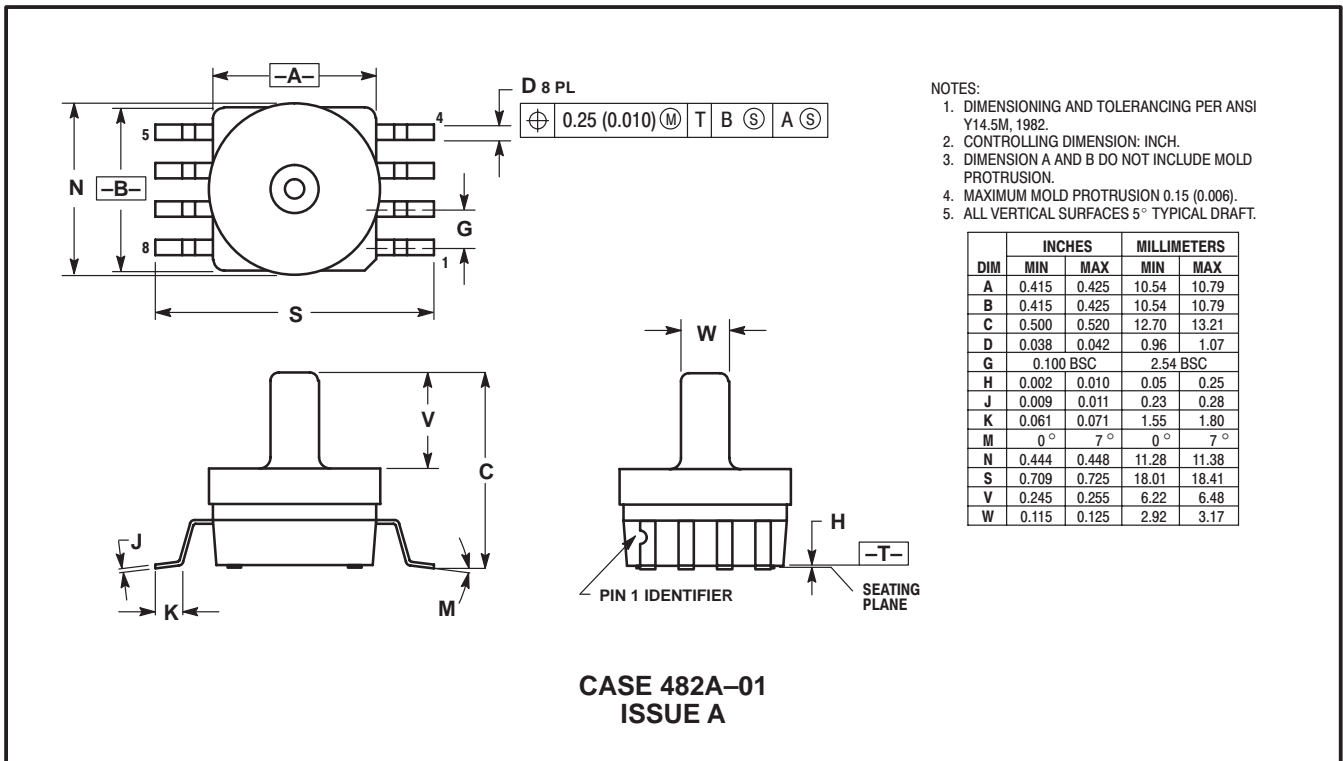
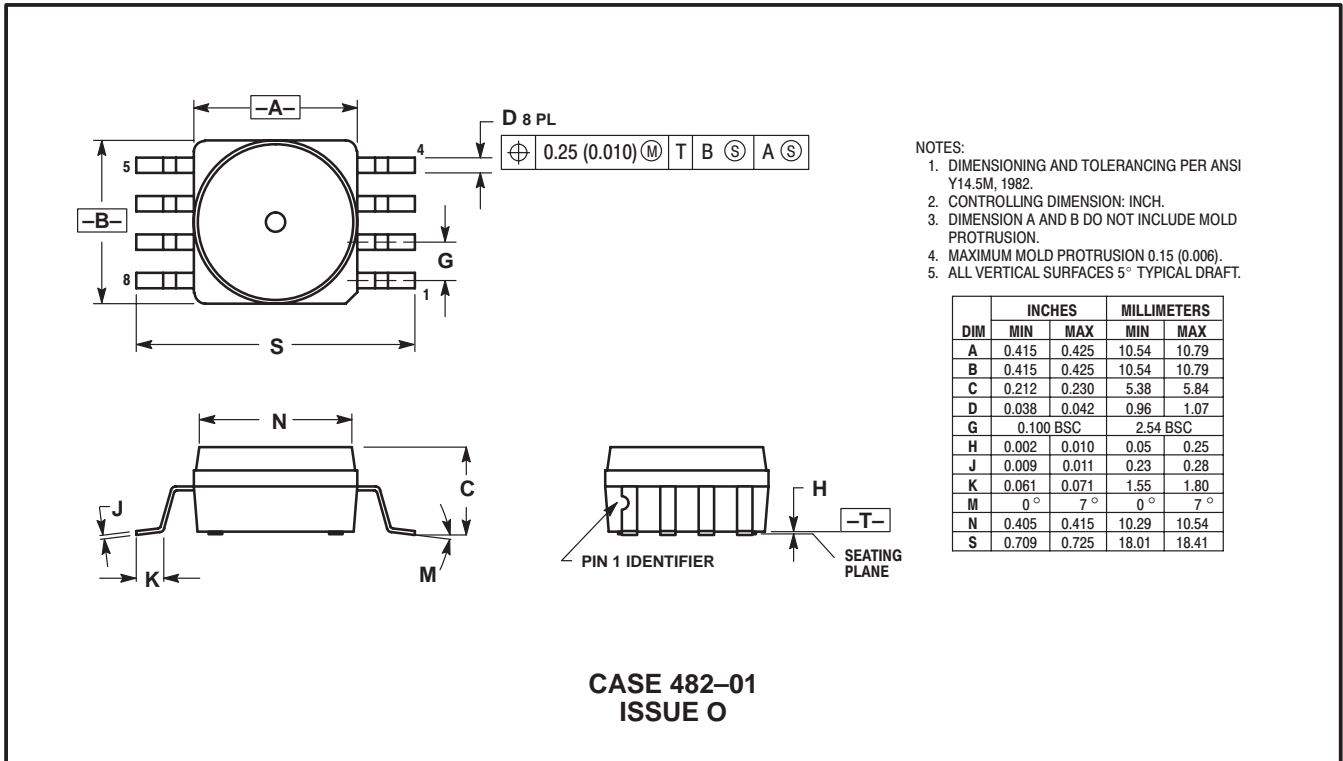

MPX4100A MPXA4100A SERIES

Motorola reserves the right to make changes without further notice to any products herein. Motorola makes no warranty, representation or guarantee regarding the suitability of its products for any particular purpose, nor does Motorola assume any liability arising out of the application or use of any product or circuit, and specifically disclaims any and all liability, including without limitation consequential or incidental damages. "Typical" parameters which may be provided in Motorola data sheets and/or specifications can and do vary in different applications and actual performance may vary over time. All operating parameters, including "Typicals" must be validated for each customer application by customer's technical experts. Motorola does not convey any license under its patent rights nor the rights of others. Motorola products are not designed, intended, or authorized for use as components in systems intended for surgical implant into the body, or other applications intended to support or sustain life, or for any other application in which the failure of the Motorola product could create a situation where personal injury or death may occur. Should Buyer purchase or use Motorola products for any such unintended or unauthorized application, Buyer shall indemnify and hold Motorola and its officers, employees, subsidiaries, affiliates, and distributors harmless against all claims, costs, damages, and expenses, and reasonable attorney fees arising out of, directly or indirectly, any claim of personal injury or death associated with such unintended or unauthorized use, even if such claim alleges that Motorola was negligent regarding the design or manufacture of the part. Motorola and  are registered trademarks of Motorola, Inc. Motorola, Inc. is an Equal Opportunity/Affirmative Action Employer.

How to reach us:

USA/EUROPE/Locations Not Listed: Motorola Literature Distribution;
P.O. Box 5405, Denver, Colorado 80217. 1-303-675-2140 or 1-800-441-2447

Technical Information Center: 1-800-521-6274

JAPAN: Motorola Japan Ltd.; SPS, Technical Information Center, 3-20-1,
Minami-Azabu, Minato-ku, Tokyo 106-8573 Japan. 81-3-3440-3569

ASIA/PACIFIC: Motorola Semiconductors H.K. Ltd.; Silicon Harbour Centre,
2, Dai King Street, Tai Po Industrial Estate, Tai Po, N.T., Hong Kong.
852-26668334

HOME PAGE: <http://www.motorola.com/semiconductors/>