



Digitally Controlled Programmable Gain Amplifier in SOT-23

March 2003

FEATURES

- 3-Bit Digital Gain Control (0, 1, 2, 4, 8, 16, 32 and 64V/V)
- 8-Pin TSOT-23 Package
- Rail-to-Rail Input Range
- Rail-to-Rail Output Swing
- Single or Dual Supply: 2.7V to 10.5V Total
- 13MHz Gain Bandwidth Product
- 13nV/√Hz Input Noise at Gain of 64
- 120dB Total System Dynamic Range
- Input Offset Voltage: 3mV (Gain = 1)
- Input Offset Voltage: 2mV (Gain = 8)

DESCRIPTION

The LTC[®]6910-2 is a low noise digitally programmable gain amplifier (PGA) that is easy to use and occupies very little PC board space. The gain is adjustable using a 3-bit digital input to select inverting gains of 0, 1, 2, 4, 8, 16, 32 and 64V/V.

The LTC6910-2 is an inverting amplifier with a rail-to-rail output. When operated with unity gain, the LTC6910-2 will also process rail-to-rail input signals. A half-supply reference generated internally at the AGND pin supports single power supply applications. Operating from single or split supplies from 2.7V to 10.5V, the LTC6910-2 is offered in an 8-lead TSOT-23 package.

For other gain options, see the LTC6910-1 and LTC6910-3.

LT, LTC and LT are registered trademarks of Linear Technology Corporation.

APPLICATIONS

- Data Acquisition Systems
- Dynamic Gain Changing
- Automatic Ranging Circuits
- Automatic Gain Control

TYPICAL APPLICATION

Single Supply Programmable Amplifier

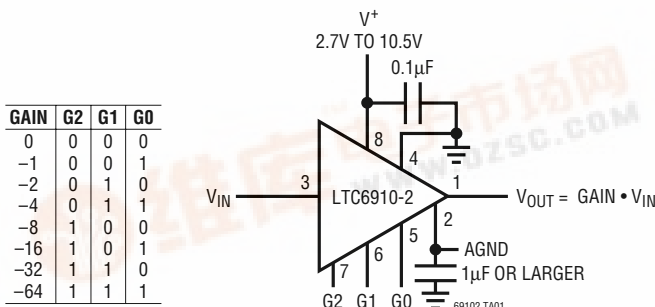

PIN 2 (AGND) PROVIDES BUILT-IN HALF-SUPPLY REFERENCE WITH INTERNAL RESISTANCE OF 5k. AGND CAN ALSO BE DRIVEN BY A SYSTEM ANALOG GROUND REFERENCE NEAR HALF SUPPLY

Frequency Response

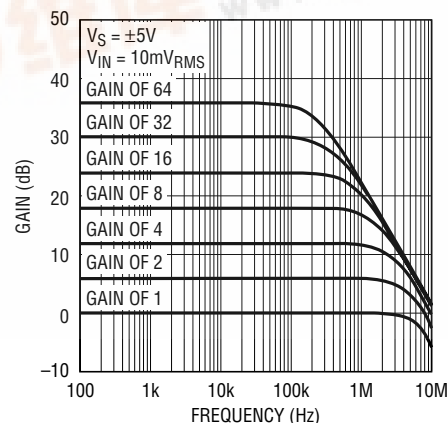

69102 TA02



LTC6910-2

ABSOLUTE MAXIMUM RATINGS

(Note 1)

Total Supply Voltage (V+ to V-)	11V
Input Current	±25mA
Operating Temperature Range (Note 2)	
LTC6910-2C	-40°C to 85°C
LTC6910-2I	-40°C to 85°C
Specified Temperature Range (Note 3)	
LTC6910-2C	-40°C to 85°C
LTC6910-2I	-40°C to 85°C
Storage Temperature Range	-65°C to 150°C
Lead Temperature (Soldering, 10 sec)	300°C

PACKAGE/ORDER INFORMATION

<p>TOP VIEW</p> <p>OUT 1 8 V+</p> <p>AGND 2 7 G2</p> <p>IN 3 6 G1</p> <p>V- 4 5 G0</p> <p>TS8 PACKAGE 8-LEAD PLASTIC TSOT-23 T_{JMAX} = 150°C, θ_{JA} = 230°C/W</p>	ORDER PART NUMBER
	LTC6910-2CTS8 LTC6910-2ITS8
	TS8 PART MARKING*
	LTACQ

*The temperature grades are identified by a label on the shipping container. Consult LTC Marketing for parts specified with wider operating temperature ranges or other gain ranges.

GAIN SETTINGS AND PROPERTIES

Table 1

DIGITAL INPUTS			NOMINAL VOLTAGE GAIN		NOMINAL LINEAR INPUT RANGE (V _{p-p}), R _L = 10k			NOMINAL INPUT IMPEDANCE (kΩ)
					Dual 5V Supply	Single 5V Supply	Single 3V Supply	
G2	G1	G0	Volts/Volt	(dB)				
0	0	0	0	-120	10	5	3	(Open)
0	0	1	-1	0	10	5	3	10
0	1	0	-2	6	5	2.5	1.5	5
0	1	1	-4	12	2.5	1.25	0.75	2.5
1	0	0	-8	18.06	1.25	0.625	0.375	1.25
1	0	1	-16	24.08	0.625	0.313	0.188	1.25
1	1	0	-32	30.1	0.313	0.156	0.094	1.25
1	1	1	-64	36.12	0.156	0.078	0.047	1.25

ELECTRICAL CHARACTERISTICS

The ● denotes the specifications that apply over the full operating temperature range, otherwise specifications are at T_A = 25°C. V_S = 5V, AGND = 2.5V, Gain = 1 (Digital Inputs 001), R_L = 10k to midsupply point, unless otherwise noted.

PARAMETER	CONDITIONS	MIN	TYP	MAX	UNITS
Voltage Gain (Note 4)	V _S = 2.7V, Gain = 1, R _L = 10k	● -0.06	0	0.08	dB
	V _S = 2.7V, Gain = 1, R _L = 500Ω	● -0.1	-0.02	0.06	dB
	V _S = 2.7V, Gain = 2, R _L = 10k	● 5.96	6.02	6.10	dB
	V _S = 2.7V, Gain = 4, R _L = 10k	● 11.9	12.02	12.12	dB
	V _S = 2.7V, Gain = 8, R _L = 10k	● 17.80	17.98	18.15	dB
	V _S = 2.7V, Gain = 8, R _L = 500Ω	● 17.65	17.95	18.15	dB
	V _S = 2.7V, Gain = 16, R _L = 10k	● 23.75	24	24.2	dB
	V _S = 2.7V, Gain = 32, R _L = 10k	● 29.7	30	30.2	dB
	V _S = 2.7V, Gain = 64, R _L = 10k	● 35.3	35.75	36.2	dB
	V _S = 2.7V, Gain = 64, R _L = 500Ω	● 34.2	35.30	36.2	dB

ELECTRICAL CHARACTERISTICS The ● denotes the specifications that apply over the full operating temperature range, otherwise specifications are at $T_A = 25^\circ\text{C}$. $V_S = 5\text{V}$, $\text{AGND} = 2.5\text{V}$, $\text{Gain} = 1$ (Digital Inputs 001), $R_L = 10\text{k}$ to midsupply point, unless otherwise noted.

PARAMETER	CONDITIONS		MIN	TYP	MAX	UNITS
Voltage Gain (Note 4)	$V_S = 5\text{V}$, Gain = 1, $R_L = 10\text{k}$	●	-0.06	0	0.08	dB
	$V_S = 5\text{V}$, Gain = 1, $R_L = 500\Omega$	●	-0.1	-0.01	0.08	dB
	$V_S = 5\text{V}$, Gain = 2, $R_L = 10\text{k}$	●	5.96	6.02	6.10	dB
	$V_S = 5\text{V}$, Gain = 4, $R_L = 10\text{k}$	●	11.85	12.02	12.15	dB
	$V_S = 5\text{V}$, Gain = 8, $R_L = 10\text{k}$	●	17.85	18.0	18.15	dB
	$V_S = 5\text{V}$, Gain = 8, $R_L = 500\Omega$	●	17.65	17.9	18.15	dB
	$V_S = 5\text{V}$, Gain = 16, $R_L = 10\text{k}$	●	23.85	24	24.15	dB
	$V_S = 5\text{V}$, Gain = 32, $R_L = 10\text{k}$	●	29.7	30	30.2	dB
	$V_S = 5\text{V}$, Gain = 64, $R_L = 10\text{k}$	●	35.6	35.9	36.2	dB
	$V_S = 5\text{V}$, Gain = 64, $R_L = 500\Omega$	●	34.8	35.5	36.0	dB
	$V_S = \pm 5\text{V}$, Gain = 1, $R_L = 10\text{k}$	●	-0.05	0	0.07	dB
	$V_S = \pm 5\text{V}$, Gain = 1, $R_L = 500\Omega$	●	-0.1	-0.01	0.08	dB
	$V_S = \pm 5\text{V}$, Gain = 2, $R_L = 10\text{k}$	●	5.96	6.02	6.10	dB
	$V_S = \pm 5\text{V}$, Gain = 4, $R_L = 10\text{k}$	●	11.9	12.02	12.15	dB
	$V_S = \pm 5\text{V}$, Gain = 8, $R_L = 10\text{k}$	●	17.85	18.00	18.15	dB
	$V_S = \pm 5\text{V}$, Gain = 8, $R_L = 500\Omega$	●	17.80	17.95	18.10	dB
	$V_S = \pm 5\text{V}$, Gain = 16, $R_L = 10\text{k}$	●	23.85	24	24.15	dB
	$V_S = \pm 5\text{V}$, Gain = 32, $R_L = 10\text{k}$	●	29.85	30	30.15	dB
	$V_S = \pm 5\text{V}$, Gain = 64, $R_L = 10\text{k}$	●	35.7	35.95	36.2	dB
	$V_S = \pm 5\text{V}$, Gain = 64, $R_L = 500\Omega$	●	35.2	35.80	36.2	dB
Signal Attenuation at Gain = 0 Setting	Gain = 0 (Digital Inputs 000), $f = 20\text{kHz}$	●		-122		dB
Total Supply Voltage		●	2.7		10.5	V
Supply Current	$V_S = 2.7\text{V}$, $V_{IN} = 1.35\text{V}$	●		2	3	mA
	$V_S = 5\text{V}$, $V_{IN} = 2.5\text{V}$	●		2.4	3.5	mA
	$V_S = \pm 5\text{V}$, $V_{IN} = 0\text{V}$, Pins 5, 6, 7 = -5V or 5V	●		3	4.5	mA
	$V_S = \pm 5\text{V}$, $V_{IN} = 0\text{V}$, Pins 5 = 4.5V, Pins 6, 7 = 0.5V (Note 5)	●		3.5	4.9	mA
Output Voltage Swing LOW (Note 6)	$V_S = 2.7\text{V}$, $R_L = 10\text{k}$ to Midsupply Point	●		12	30	mV
	$V_S = 2.7\text{V}$, $R_L = 500\Omega$ to Midsupply Point	●		50	100	mV
	$V_S = 5\text{V}$, $R_L = 10\text{k}$ to Midsupply Point	●		20	40	mV
	$V_S = 5\text{V}$, $R_L = 500\Omega$ to Midsupply Point	●		90	160	mV
	$V_S = \pm 5\text{V}$, $R_L = 10\text{k}$ to 0V	●		30	50	mV
	$V_S = \pm 5\text{V}$, $R_L = 500\Omega$ to 0V	●		180	250	mV
Output Voltage Swing HIGH (Note 6)	$V_S = 2.7\text{V}$, $R_L = 10\text{k}$ to Midsupply Point	●		10	20	mV
	$V_S = 2.7\text{V}$, $R_L = 500\Omega$ to Midsupply Point	●		50	80	mV
	$V_S = 5\text{V}$, $R_L = 10\text{k}$ to Midsupply Point	●		10	30	mV
	$V_S = 5\text{V}$, $R_L = 500\Omega$ to Midsupply Point	●		80	150	mV
	$V_S = \pm 5\text{V}$, $R_L = 10\text{k}$ to 0V	●		20	40	mV
	$V_S = \pm 5\text{V}$, $R_L = 500\Omega$ to 0V	●		180	250	mV
Output Short-Circuit Current (Note 7)	$V_S = 2.7\text{V}$			± 27		mA
	$V_S = \pm 5\text{V}$			± 35		mA
AGND Open-Circuit Voltage	$V_S = 5\text{V}$	●	2.45	2.5	2.55	V
AGND (Common Mode) Input Voltage Range (Note 8)	$V_S = 2.7\text{V}$	●	0.85		1.55	V
	$V_S = 5\text{V}$	●	0.7		3.60	V
	$V_S = \pm 5\text{V}$	●	-4.3		3.40	V

LTC6910-2

ELECTRICAL CHARACTERISTICS The ● denotes the specifications that apply over the full operating temperature range, otherwise specifications are at $T_A = 25^\circ\text{C}$. $V_S = 5\text{V}$, $V_{AGND} = 2.5\text{V}$, Gain = 1 (Digital Inputs 001), $R_L = 10\text{k}$ to midsupply point, unless otherwise noted.

PARAMETER	CONDITIONS		MIN	TYP	MAX	UNITS
AGND Rejection (i.e., Common Mode Rejection or CMRR)	$V_S = 2.7\text{V}$, $V_{AGND} = 1.1\text{V}$ to 1.6V $V_S = \pm 5\text{V}$, $V_{AGND} = -2.5$ to 2.5	●	55	80		dB
		●	55	75		dB
Power Supply Rejection Ratio (PSRR)	$V_S = 2.7\text{V}$ to $\pm 5\text{V}$	●	60	80		dB
Offset Voltage Magnitude (Referred to Input)	Gain = 1 Gain = 8	●		3	15	mV
		●		2	10	mV
DC Input Resistance (Note 9)	DC $V_{IN} = 0\text{V}$ Gain = 0 Gain = 1 Gain = 2 Gain = 4 Gain = 8, 16, 32, 64			>100		M Ω
		●		10		k Ω
		●		5		k Ω
		●		2.5		k Ω
		●		1.25		k Ω
DC Small-Signal Output Resistance	Gain = 0 Gain = 1 Gain = 2 Gain = 4 Gain = 8 Gain = 16 Gain = 32 Gain = 64			0.4		Ω
				0.7		Ω
				1		Ω
				1.6		Ω
				2.8		Ω
				5		Ω
				10		Ω
		20		Ω		
Gain-Bandwidth Product	Gain = 64, $f_{IN} = 200\text{kHz}$		9	13	16	MHz
		●	7		19	MHz
Slew Rate	$V_S = 5\text{V}$, $V_{OUT} = 2.8\text{V}_{P-P}$ $V_S = \pm 5\text{V}$, $V_{OUT} = 2.8\text{V}_{P-P}$			12		V/ μs
				16		V/ μs
Wideband Noise (Referred to Input)	f = 1kHz to 200kHz Gain = 0 Output Noise Gain = 1 Gain = 2 Gain = 4 Gain = 8 Gain = 16 Gain = 32 Gain = 64			3.7		μV_{RMS}
				10.3		μV_{RMS}
				7		μV_{RMS}
				5.3		μV_{RMS}
				4.4		μV_{RMS}
				4.2		μV_{RMS}
				4		μV_{RMS}
				3.6		μV_{RMS}
Voltage Noise Density (Referred to Input)	f = 50kHz Gain = 1 Gain = 2 Gain = 4 Gain = 8 Gain = 16 Gain = 32 Gain = 64			25		nV/ $\sqrt{\text{Hz}}$
				17		nV/ $\sqrt{\text{Hz}}$
				13		nV/ $\sqrt{\text{Hz}}$
				11		nV/ $\sqrt{\text{Hz}}$
				9.9		nV/ $\sqrt{\text{Hz}}$
				9.6		nV/ $\sqrt{\text{Hz}}$
				9.1		nV/ $\sqrt{\text{Hz}}$
Total Harmonic Distortion	Gain = 8, $f_{IN} = 10\text{kHz}$, $V_{OUT} = 1\text{V}_{RMS}$			-90		dB
				0.003		%
	Gain = 8, $f_{IN} = 100\text{kHz}$, $V_{OUT} = 1\text{V}_{RMS}$			-77		dB
				0.014		%

ELECTRICAL CHARACTERISTICS

The ● denotes the specifications that apply over the full operating temperature range, otherwise specifications are at $T_A = 25^\circ\text{C}$. $V_S = 5\text{V}$, $\text{AGND} = 2.5\text{V}$, $\text{Gain} = 1$ (Digital Inputs 001), $R_L = 10\text{k}$ to midsupply point, unless otherwise noted.

PARAMETER	CONDITIONS	MIN	TYP	MAX	UNITS
Digital Input "High" Voltage	$V_S = 2.7\text{V}$	● 2.43			V
	$V_S = 5\text{V}$	● 4.5			V
	$V_S = \pm 5\text{V}$	● 4.5			V
Digital Input "Low" Voltage	$V_S = 2.7\text{V}$	●		0.27	V
	$V_S = 5\text{V}$	●		0.5	V
	$V_S = \pm 5\text{V}$	●		0.5	V

Note 1: Absolute Maximum Ratings are those values beyond which the life of the device may be impaired.

Note 2: The LTC6910-2C and LTC6910-2I are guaranteed functional over the operating temperature range of -40°C to 85°C .

Note 3: The LTC6910-2C is guaranteed to meet specified performance from 0°C to 70°C . The LTC6910-2C is designed, characterized and expected to meet specified performance from -40°C to 85°C but is not tested or QA sampled at these temperatures. LTC6910-2I is guaranteed to meet specified performance from -40°C to 85°C .

Note 4: Gain is measured with a DC large-signal test using an output excursion between approximately -40% and 40% of half supply.

Note 5: Operating all three digital inputs at 0.5V causes supply current to increase typically 0.1mA from this specification.

Note 6: Output voltage swings are measured as differences between the output and the respective supply rail.

Note 7: Extended operation with output shorted may cause the junction temperature to exceed the 150°C limit and is not recommended.

Note 8: Open-loop gain of the internal op amp falls by approximately 15dB at the limits of the AGND voltage range.

Note 9: Input resistance can vary by approximately $\pm 30\%$.

PIN FUNCTIONS

OUT (Pin 1): Analog Output. This is the output of an internal operational amplifier and swings to near the power supply rails (V^+ and V^-) as specified in the Electrical Characteristics table. The internal op amp remains active at all times, including the zero gain setting (digital input 000). As with other amplifier circuits, loading the output as lightly as possible will minimize signal distortion and gain error. The Electrical Characteristics table shows performance at output currents up to 10mA . Currents above 10mA are possible but current-limiting circuitry will begin to affect amplifier performance at approximately 20mA . Long-term operation above 20mA output is not recommended. Do not exceed maximum junction temperature of 150°C . The output will drive capacitive loads up to 50pF . Capacitances higher than 50pF should be isolated by a series resistor to preserve AC stability.

AGND (Pin 2): Analog Ground. The AGND pin is at the midpoint of an internal resistive voltage divider, developing a potential halfway between the V^+ and V^- pins, with an equivalent series resistance to the pin of nominally $5\text{k}\Omega$ (Figure 3). AGND is also the noninverting input of the internal op amp, which makes it the ground reference voltage for the IN and OUT pins. Because of this, very

"clean" grounding is important, including an analog ground plane surrounding the package. For dual supply operation, this ground plane should be at zero volts and the AGND pin should connect directly to the ground plane (Figure 1). For single supply operation, in contrast, the V^- pin typically connects to system signal ground. The ground plane should then tie to V^- and the AGND pin should be AC-bypassed to the ground plane (Figure 2) by at least a $1\mu\text{F}$ high quality capacitor.

In noise-sensitive single-supply applications, it is important to AC-bypass the AGND pin. Otherwise wideband noise will enter the signal path from the internal voltage-divider resistors that set the DC voltage on AGND in single-supply applications. This noise can reduce SNR by 3dB at high gain settings. The resistors present a Thévenin equivalent of approximately 5k to the AGND pin. An external capacitor from AGND to the ground plane, whose impedance is well below 5k at frequencies of interest, will suppress this noise. A $1\mu\text{F}$ high quality capacitor is effective for frequencies down to 1kHz . Larger capacitors extend this suppression to proportionately lower frequencies. This issue does not arise in dual supply applications because AGND goes directly to ground.

PIN FUNCTIONS

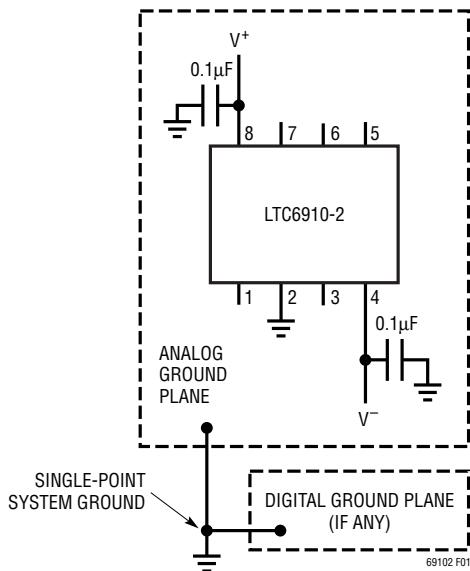

Figure 1. Dual Supply Ground Plane Connection

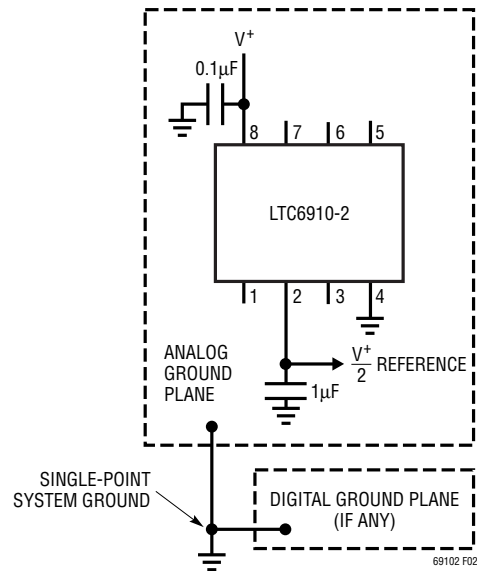

Figure 2. Single Supply Ground Plane Connection

IN (Pin 3): Analog Input. The input signal to the amplifier in the LTC6910-2 is the voltage difference between the IN and AGND pins. The IN pin connects internally to a digitally controlled resistance whose other end is a current summing point at the same potential as the AGND pin (Figure 3). At unity gain (digital input 001), the value of this input resistance is approximately 10kΩ and the IN voltage range is rail-to-rail (V^+ to V^-). At gain settings above unity (digital input 010 or higher), the input resistance falls, to nominally 1.25kΩ at gain settings of 8V/V or greater (digital input 100 or greater). Also, the linear input range falls in inverse proportion to gain. (The higher gains are designed to boost lower level signals with good noise performance.) In the “zero” gain state (digital input 000), analog switches disconnect the IN pin internally and this pin presents a very high input resistance. The input may vary from rail to rail in the “zero” gain setting but the output is insensitive to it and remains at the AGND potential. Table 1 summarizes the LTC6910-2’s behavior for all gain codes. Circuitry driving the IN pin must consider the LTC6910-2’s input resistance and the variation of this resistance when used at multiple gain settings. Signal sources with significant output resistance may introduce a gain error as the source’s output resistance and the LTC6910-2’s input resistance form a voltage divider. This is especially true at the higher gain settings where the input resistance is lowest.

In single supply voltage applications at elevated gain settings (digital input 010 or higher), it is important to remember that the LTC6910-2’s DC ground reference for both input and output is AGND, not V^- . With increasing gains, the LTC6910-2’s input voltage range for unclipped output is no longer rail-to-rail but shrinks toward AGND.

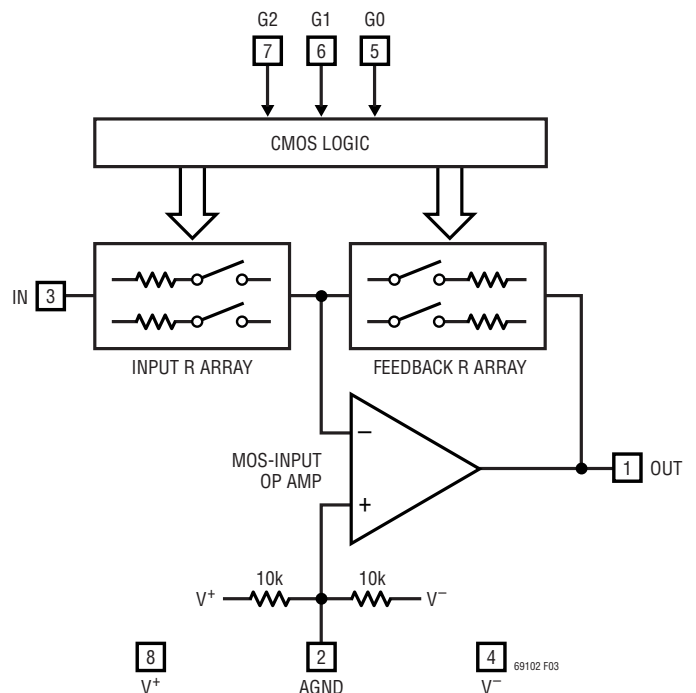

Figure 3. Block Diagram

PIN FUNCTIONS

The OUT pin also swings positive or negative with respect to AGND. At unity gain (digital input 001), both IN and OUT voltages can swing from rail to rail (Table 1).

V⁻, V⁺ (Pins 4, 8): Power Supply Pins. The V⁺ and V⁻ pins should be bypassed with 0.1 μ F capacitors to an adequate analog ground plane using the shortest possible wiring. Electrically clean supplies and a low impedance ground are important for the high dynamic range available from the LTC6910-2 (see further details under AGND). Low noise linear power supplies are recommended. Switching power supplies require special care to prevent switching noise coupling into the signal path, reducing dynamic range.

G0, G1, G2 (Pins 5, 6, 7): CMOS-Level Digital Gain-Control Inputs. G2 is the most significant bit (MSB). These pins control the voltage gain from IN to OUT pins. In the LTC6910-2, the voltage gain range is 0 to 64V/V in eight discrete values 0, 1, 2, 4, 8, 16, 32, 64, set respectively by digital inputs 000 through 111 (or in decimal form, 0 through 7). Digital input code 000 causes a “zero” gain with very low output noise. In this “zero” gain state the IN pin is disconnected internally, but the OUT pin remains active and forced by the internal op amp to the voltage present on the AGND pin. Note that the voltage gain is inverting: OUT and IN pins always swing on opposite sides of the AGND potential. The G pins are high impedance CMOS logic inputs and must be connected (they will float to unpredictable voltages if open circuited). Table 1 summarizes the effects of the G-pin code.

APPLICATIONS INFORMATION

Functional Description

The LTC6910-2 is a small outline, wideband inverting DC amplifier whose voltage gain is digitally programmable. It delivers a choice of eight voltage gains, controlled by the 3-bit digital inputs to the G pins, which accept CMOS logic levels. The gain code is always monotonic; an increase in the 3-bit binary number (G2 G1 G0) causes an increase in the gain. LTC6910-2's nominal gain magnitudes are 0, 1, 2, 4, 8, 16, 32 and 64Volts/Volt. At nonzero gains, the signal bandwidth varies roughly inversely with gain, so that the product of gain and bandwidth (to -3dB rolloff) is typically 13MHz. Gain control within the amplifier occurs by switching resistors from a matched array in or out of a closed-loop op amp circuit using MOS analog switches (Figure 3).

Digital Control

Logic levels for the LTC6910-2 digital gain control inputs (Pins 5, 6, 7) are nominally rail-to-rail CMOS. Logic 1 is V⁺, logic 0 is V⁻ or alternatively 0V when using \pm 5V supplies. The part is tested with the values listed in the Electrical Characteristics table (Digital Input “High” and “Low” Voltages), which are 10% and 90% of full excursion on the

inputs. That is, the tested logic levels are \pm 1.08V with \pm 1.35V supplies, \pm 2V with \pm 2.5V supplies (equivalently, 0.5V and 4.5V levels with 0V and 5V supply rails), and 0.5V and 4.5V logic levels at \pm 5V supplies.

Construction and Instrumentation Cautions

Electrically clean construction is important in applications seeking the full dynamic range of the LTC6910-2 amplifier. Short, direct wiring will minimize parasitic capacitance and inductance. High quality supply bypass capacitors of 0.1 μ F near the chip provide good decoupling from a clean, low inductance power source. But several cm of wire (i.e., a few microhenrys of inductance) from the power supplies, unless decoupled by substantial capacitance (\geq 10 μ F) near the chip, can cause a high-Q LC resonance in the hundreds of kHz in the chip's supplies or ground reference. This may impair circuit performance at those frequencies. A compact, carefully laid out printed circuit board with a good ground plane makes a significant difference in distortion minimizing. Finally, equipment to measure amplifier performance can itself introduce distortion or noise floors. Checking for these limits with a wire replacing the chip is a prudent routine procedure.

LTC6910-2

TYPICAL APPLICATION

Expanding an ADC's Dynamic Range

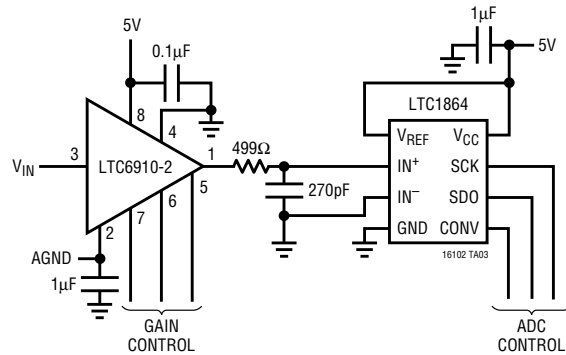

LTC6910-2 (IN TSOT-23 PACKAGE) COMPACTLY ADDS 36dB OF INPUT GAIN RANGE TO THE LTC1864 (IN MSOP 8-PIN PACKAGE). SINGLE 5V SUPPLY

PACKAGE DESCRIPTION

TS8 Package 8-Lead Plastic TSOT-23 (Reference LTC DWG # 05-08-1637)

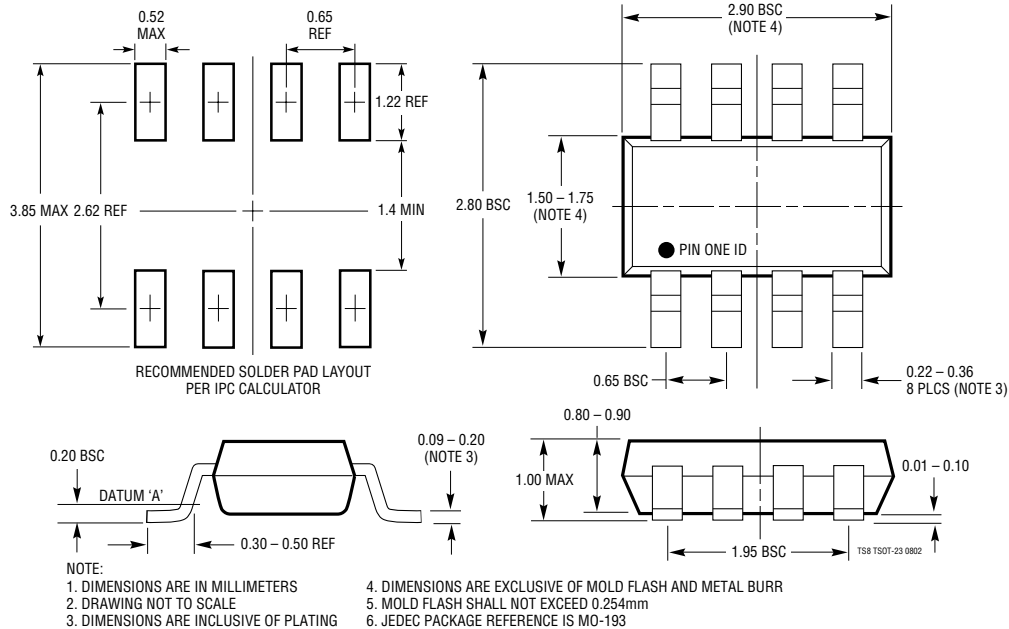

RELATED PARTS

PART NUMBER	DESCRIPTION	COMMENTS
LT [®] 1228	100MHz Gain Controlled Transconductance Amplifier	Differential Input, Continuous Analog Gain Control
LT1251/LT1256	40MHz Video Fader and Gain Controlled Amplifier	Two Input, One Output, Continuous Analog Gain Control
LTC1564	10kHz to 150kHz Digitally Controlled Filter and PGA	Continuous Time, Low Noise 8th Order Filter and 4-Bit PGA
LTC6910-1	Digitally Controlled PGA	SOT-23, Gains 0, 1, 2, 5, 10, 20, 50, 100V/V
LTC6910-3	Digitally Controlled PGA	SOT-23, Gains 0, 1, 2, 4, 3, 4, 5, 6, 7V/V