

TOSHIBA

TMP47P410A

CMOS 4-BIT MICROCONTROLLER

TMP47P410AN
TMP47P410AF

The 47P410A is the system evaluation LSI of 47C210A/410A with 32K bits one-time PROM. The 47P410A programs / verifies using an adapter socket to connect with PROM programmer, as it is in TMM2764AD. In addition, the 47P410A and the 47C210A/410A are pin compatible. The 47P400A operates as the same as the 47C210A/410A by programming to the internal PROM. The 47P410A can be used to evaluate 47C212A/412A.

PART No.	ROM	RAM	PACKAGE	ADAPTOR SOCKET
TMP47P410AN	OTP	256 × 4-bit	SDIP42-P-600-1.78	BM1118
TMP47P410AF	4096 × 8-bit		QFP44-P-1414-0.80D	BM1125

PIN ASSIGNMENT (TOPVIEW)

SDIP42-P-600-1.78

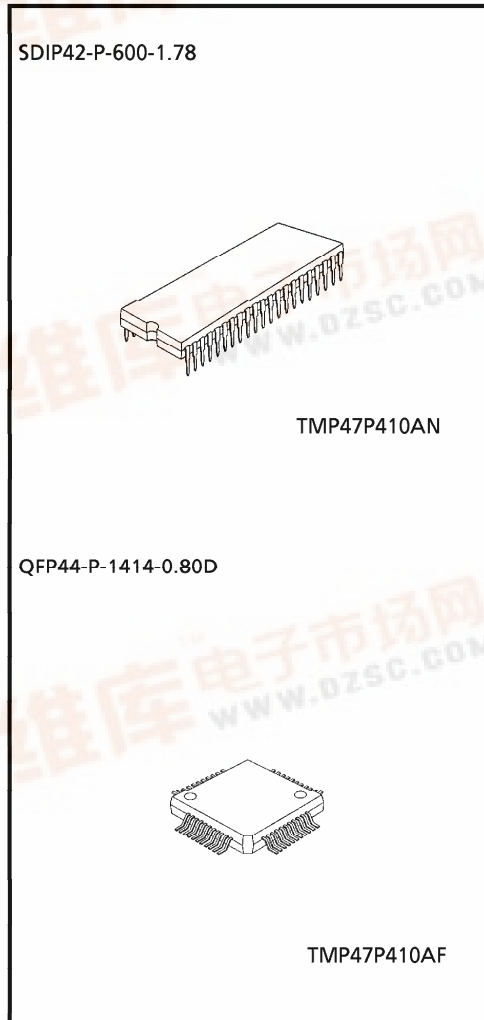
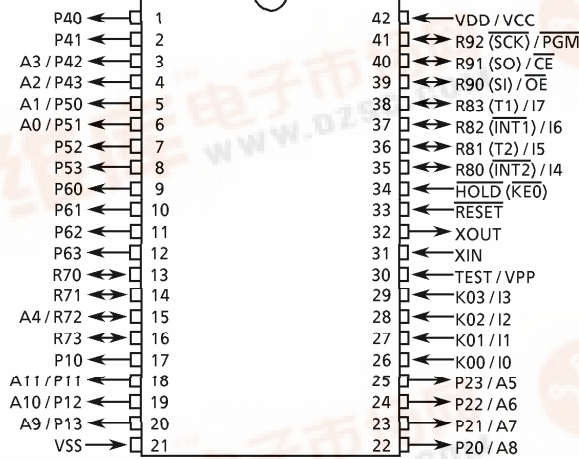

QFP44-P-1414-0.80D

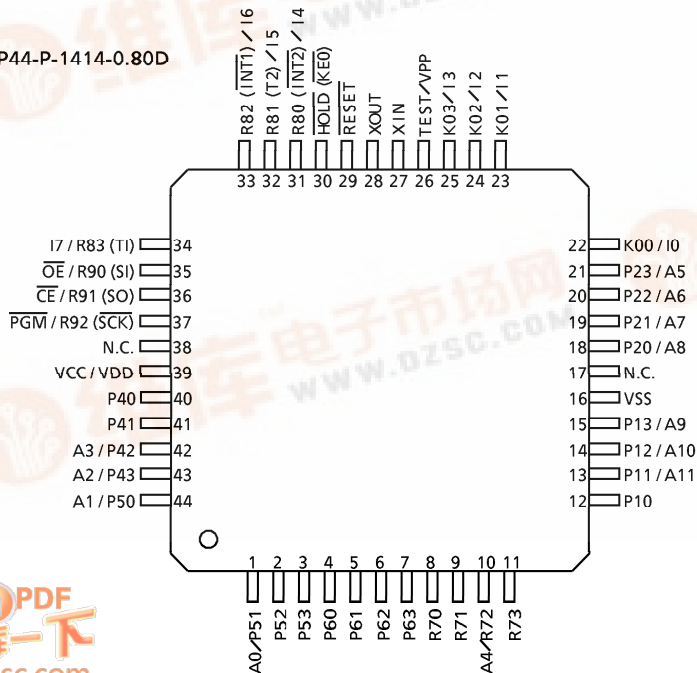

PIN FUNCTION

The 47P410A has MCU mode and PROM mode.

(1) MCU mode

The 47C410A and the 47P410A are pin compatible (TEST pin for out-going test. Be fixed to low level.).

(2) PROM mode

PIN NAME	INPUT / OUTPUT	FUNCTIONS	PIN NAME (MCU mode)
A11 to A9	INPUT	Address inputs	P11 to P13
A8 to A5			P20 to P23
A4			R72
A3 , A2			R42 , R43
A1 , A0			R50 , R51
I7 to I4	I/O	Data outputs (Inputs)	R83 to R80
I3 to I0			K03 to K00
$\overline{\text{PGM}}$	Input	Program control input	R92
$\overline{\text{CE}}$		Chip Enable input	R91
$\overline{\text{OE}}$		Output Enable input	R90
VPP	Power supply	+ 21 V / 5 V (Program supply voltage)	TEST
VCC		+ 5 V	VDD
VSS		0 V	VSS
P10	Output	Open or be fixed to Low Level.	
R41 , R40	I/O	Be fixed to Low Level	
R53 , R52			
R63 to R60			
R70, R71, R73			
$\overline{\text{RESET}}$	Input	PROM mode setting pin. Be fixed to low level.	
$\overline{\text{HOLD}}$	Input		
XIN	Input	Resonator connecting pin	
XOUT	output		

OPERATIONAL DESCRIPTION

The following is an explanation of hardware configuration and operation in relation to the 47P410A. The 47P410A is the same as the 47C210A/410A except that an OTP is used instead of a built-in mask ROM.

1. OPERATION mode

The 47P410A has an MCU mode and a PROM mode.

1.1 MCU mode

The MCU mode is set by fixing the TEST/VPP pin at the "L" level. Operation in the MCU mode is the same as for the 47C210A/410A, except that the TEST/VPP pin does not have built in pull-down resistor and cannot be used open.

1.1.1 Program Memory

The program storage area is the same as for the 47C210A/410A. Data conversion must be set in two locations when using the 47P410A to check 47C210A operation.

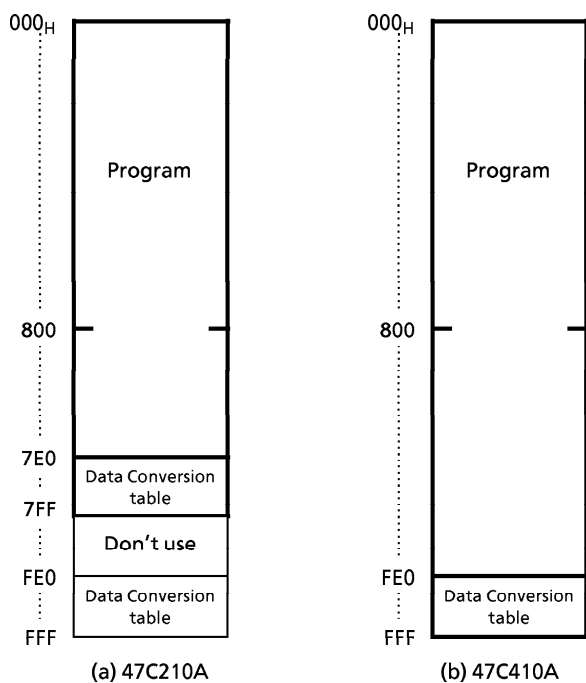

Figure 1-1. Program area (ROM)

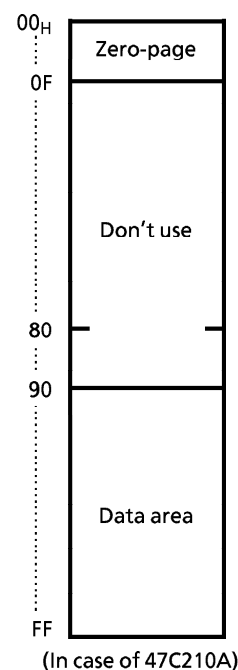

Figure 1-2. RAM addressing (RAM)

1.1.2 Data Memory

The 47P410A contains 256 × 4-bit (equivalent to 47C410A) data memory. When the 47P410A is used as evaluator of the 47C210A, programming should be performed assuming that the RAM is assigned to addresses 00 to 0FH and 90 to FFH as show in Figure 1-2 by considering the application software evaluation.

1.1.3 Input/Output Circuitry

- (1) Control pins
This is the same as for the 47C210A/410A except that there is no built-in pull-down resistance for the TEST pin.
- (2) I/O Ports
The input/output circuit of the 47P410A is the same as I/O code HA of the 47C210A/410A. External resistance, for example, is required when using as evaluator of other I/O codes (HB to HF), (Refer to Figure 1-3)

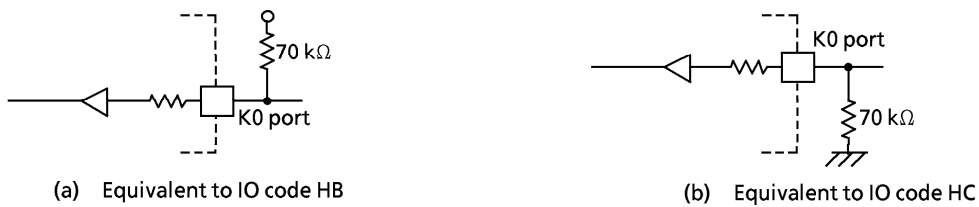

Figure 1-2. I/O code and external circuitry

※ In case using evaluator for 47C212A/412A
The 47P410A can be used as the 47C212A/47C412A evaluator by connecting an external resistor to ports P1, P2 and P4 through P6. Note that, since the 47C212A/412A have no R73 pins, "1" is read out when the input instruction is executed.

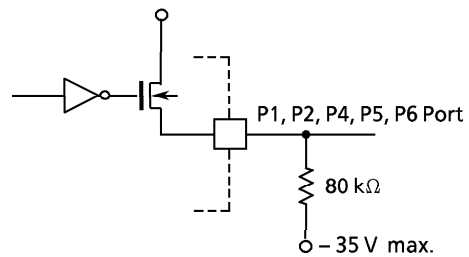
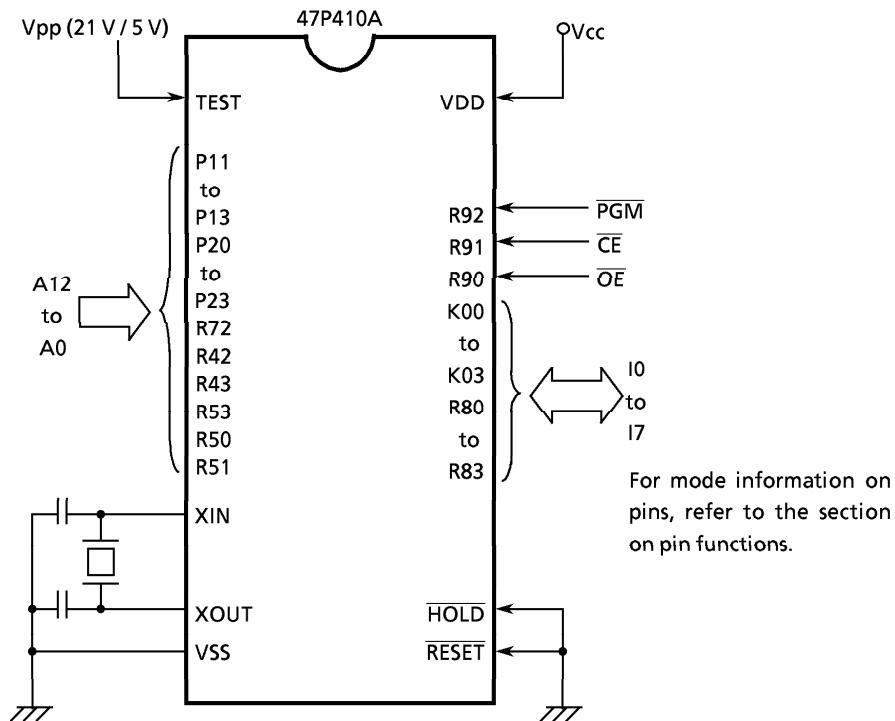

Figure 1-3. For the 47C212A/412A

1.2 PROM mode

The PROM mode is set by setting the $\overline{\text{RESET}}$ and $\overline{\text{HOLD}}$ pins to the "L" level. The PROM mode can be used as a general-purpose PROM writer for program writing and verification. (A high-speed program mode is used set the ROM type the same as for the TMM 2764D).



Note. When writing a program, set a ROM type to 2764 (programming voltage : 21V).
 Since the 47P410A has 4096 x 8 bit internal PROM (000 to FFF_H), set a stop address of a PROM writer to "FFF_H", or store the same data to the latter half addresses 1000 to 1FFF_H.

Figure 1-4. Setting for PROM mode

1.2.1 High Speed Programming Mode

The device is set up in the high speed programming mode when the programming voltage (21.0 V) is applied to the Vpp pin with Vcc = 6 V and $\overline{\text{PGM}} = V_{IH4}$. The programming is achieved by applying a single TTL low level 1 msec, pulse the $\overline{\text{PGM}}$ input after addresses and data are stable. Then the programmed data is verified by using Program Verify mode. If the programmed data is not correct, another program pulse of 1 msec is applied and then programmed data is verified. This should be repeated until the program operates correctly (max. 25 times) After correctly programming the selected address, one additional program pulse with pulse width 3 times that needed for programming is applied. When programming has been completed, the data in all addresses should be verified with Vcc = Vpp = 5 V.

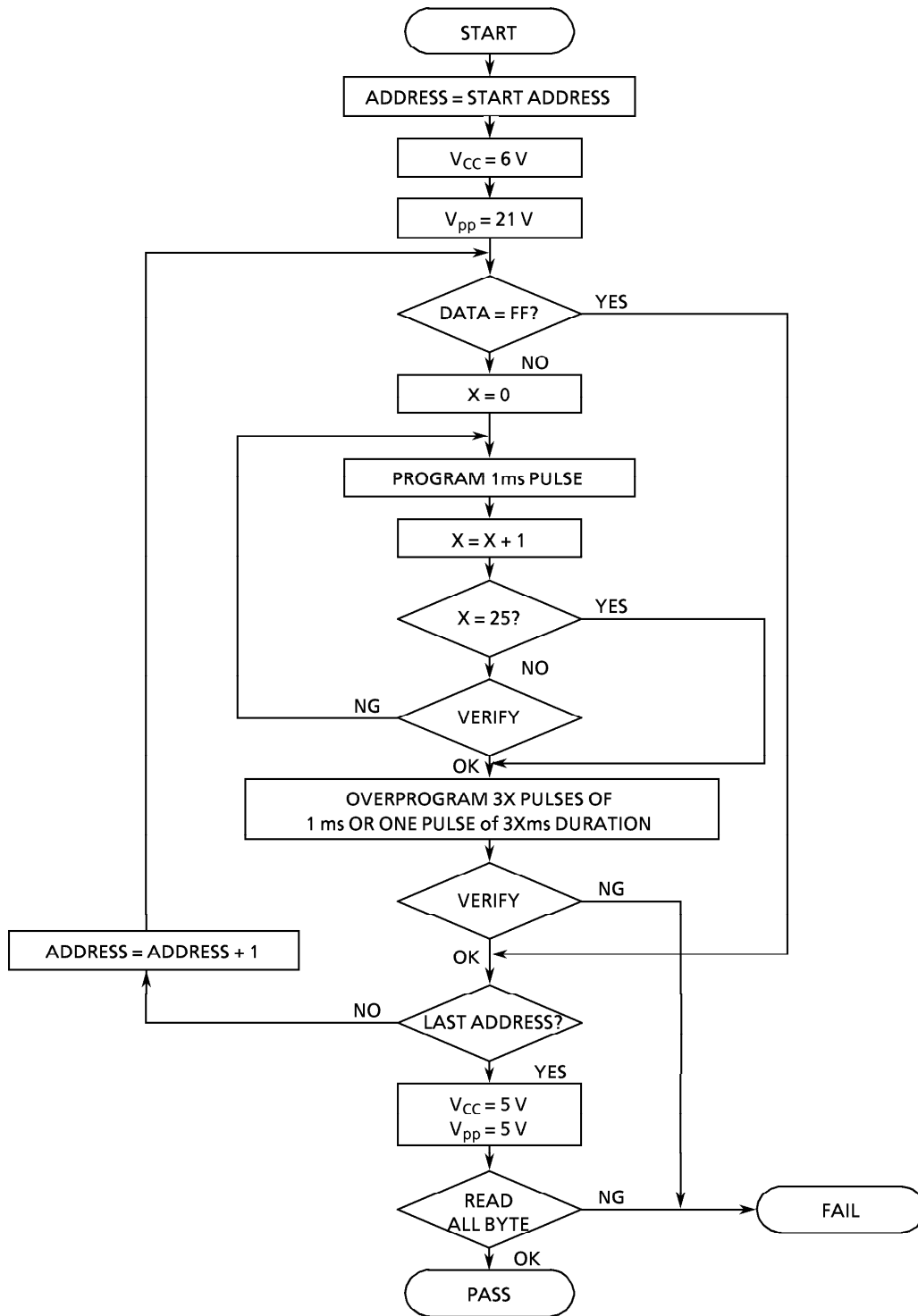

Figure1-5. Flow Chart

ELECTRICAL CHARACTERISTICS

ABSOLUTE MAXIMUM RATINGS

 $(V_{SS} = 0 \text{ V})$

PARAMETER	SYMBOL	PINS	RATING	UNIT
Supply Voltage	V_{DD}		- 0.3 to 7	V
Programming Voltage	V_{PP}	TEST / VPP pin	- 0.3 to 22.0	V
Input Voltage	V_{IN}		- 0.3 to $V_{DD} + 0.3$	V
Output Voltage	V_{OUT1}	Except sink open drain pin, but include R8	- 0.3 to $V_{DD} + 0.3$	V
	V_{OUT2}	Sink open drain pin except R8	- 0.3 to 10	
	V_{OUT3}	Source open dtain pin	- 35 to $V_{DD} + 0.3$	
Output Current (Per 1 pin)	I_{OUT1}	Ports P1, P2	- 2	mA
	I_{OUT2}	Ports P4, P5, P6	- 25	
	I_{OUT3}	Ports R7, R8, R9	3.5	
Output Current (Total)	ΣI_{OUT2}	Ports P4, P5, P6	- 100	mA
Power Dissipation	PD		600	mW
Soldering Temperature (time)	T_{sld}		260 (10 s)	°C
Storage Temperature	T_{stg}		- 55 to 125	°C
Operating Temperature	T_{opr}		- 30 to 70	°C

RECOMMENDED OPERATING CONDITIONS

 $(V_{SS} = 0 \text{ V}, T_{opr} = - 30 \text{ to } 70 \text{ }^\circ\text{C})$

PARAMETER	SYMBOL	PINS	CONDITIONS	Min.	Max.	UNIT
Supply Voltage	V_{DD}		In the Normal mode	4.5	6.0	V
			In the HOLD mode	2.0		
Input High Voltage	V_{IH1}	Except Hysteresis Input	$V_{DD} \geq 4.5 \text{ V}$	$V_{DD} \times 0.7$	V_{DD}	V
	V_{IH2}	Hysteresis Input		$V_{DD} \times 0.75$		
	V_{IH3}		$V_{DD} < 4.5 \text{ V}$	$V_{DD} \times 0.9$		
Input Low Voltage	V_{IL1}	Except Hysteresis Input	$V_{DD} \geq 4.5 \text{ V}$	0	$V_{DD} \times 0.3$	V
	V_{IL2}	Hysteresis Input			$V_{DD} \times 0.25$	
	V_{IL3}		$V_{DD} < 4.5 \text{ V}$		$V_{DD} \times 0.1$	
Clock Frequency	fc			0.4	4.2	MHz

Note. Input voltage V_{IH3} , V_{IL3} : in the HOLD mode

D.C. CHARACTERISTICS

(V_{SS} = 0 V, V_{DD} = 4.5 to 6.0 V, T_{opr} = -30 to 70 °C)

PARAMETER	SYMBOL	PINS	CONDITIONS	Min.	Typ.	Max.	UNIT
Hysteresis Voltage	V _{HS}	Hysteresis Input		—	0.7	—	V
Input Current	I _{IN1}	Port K0, TEST, RESET, HOLD	V _{DD} = 5.5 V,	—	—	± 2	μA
	I _{IN2}	Port R (open drain)	V _{IN} = 5.5 V / 0 V				
Input Resistance	R _{IN1}	Port K0 with pull-up/pull-down		30	70	150	kΩ
	R _{IN2}	RESET		100	220	450	
Output Leakage Current	I _{LO1}	Port R (open drain)	V _{DD} = 5.5 V, V _{OUT} = 5.5 V	—	—	2	μA
	I _{LO2}	Port P (open drain)	V _{DD} = 5.5 V, V _{OUT} = -32 V	—	—	-2	
Output High Voltage	V _{OH2}	Ports P1, P2	V _{DD} = 4.5 V, I _{OH} = -1.6 mA	2.4	—	—	V
	V _{OH3}	Ports P4, P5, P6	V _{DD} = 4.5 V, I _{OH} = -10 mA	2.4	—	—	
Output Low Voltage	V _{OL}	Ports R7, R8, R9	V _{DD} = 4.5 V, I _{OL} = 1.6 mA	—	—	0.4	V
Supply Current (in the Normal mode)	I _{DD}		V _{DD} = 5.5 V, f _c = 4 MHz	—	5	10	mA
Supply Current (in the HOLD mode)	I _{DDH}		V _{DD} = 5.5 V	—	0.5	10	μA

Note 1. Typ. values show those at T_{opr} = 25 °C, V_{DD} = 5 V.

Note 2. Input Current I_{IN1}: The current through resistor is not included, when the pull-up/pull-down resistor is contained.

Note 3. Supply Current : V_{IN} = 5.3 V / 0.2 V

The K0 port is opened when the pull-up/pull-down resistor is contained.

The voltage applied to the R port within the valid V_{IL} or V_{IH}.

A. C. CHARACTERISTICS

($V_{SS} = 0\text{ V}$, $V_{DD} = 4.5\text{ to }6.0\text{ V}$, $T_{opr} = -30\text{ to }70\text{ }^\circ\text{C}$)

PARAMETER	SYMBOL	CONDITIONS	Min.	Typ.	Max.	UNIT
Instruction Cycle Time	t_{cy}		1.9	—	20	μs
High level Clock pulse Width	t_{WCH}	External clock mode	80	—	—	ns
Low level Clock pulse Width	t_{WCL}					
A/D Sampling Time	t_{AIN}	$f_c = 4\text{ MHz}$	—	4	—	μs
Shift Data Hold Time	t_{SDH}		$0.5 t_{cy} - 300$	—	—	ns

Note. Shift Data Hold Time

External circuit for $\overline{\text{SCK}}$ pin and SO pin

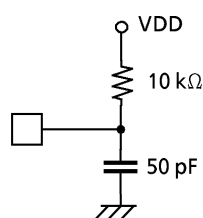

Serial port (completion of transmission)

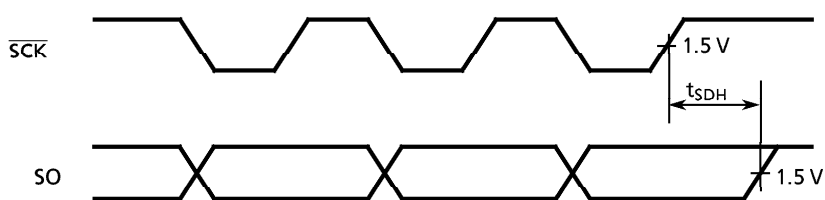

RECOMMENDED OSCILLATING CONDITIONS

($V_{SS} = 0\text{ V}$, $V_{DD} = 4.5\text{ to }6.0\text{ V}$, $T_{opr} = -30\text{ to }70\text{ }^\circ\text{C}$)

Recommended oscillating conditions of the 47P410A are equal to the 47C410A's.

DC/AC CHARACTERISTICS

($V_{SS} = 0\text{ V}$)

(1) Read Operation

PARAMETER	SYMBOL	CONDITION	Min.	Typ.	Max.	UNIT
Output Level High Voltage	V_{IH4}		$V_{CC} \times 0.8$	—	V_{CC}	V
Output Level Low Voltage	V_{IL4}		0	—	$V_{CC} \times 0.1$	V
Supply Voltage	V_{CC}		4.75	—	6.0	V
Programming Voltage	V_{PP}					
Address Access Time	t_{ACC}	$V_{CC} = 5.0 \pm 0.25\text{ V}$	—	—	350	ns

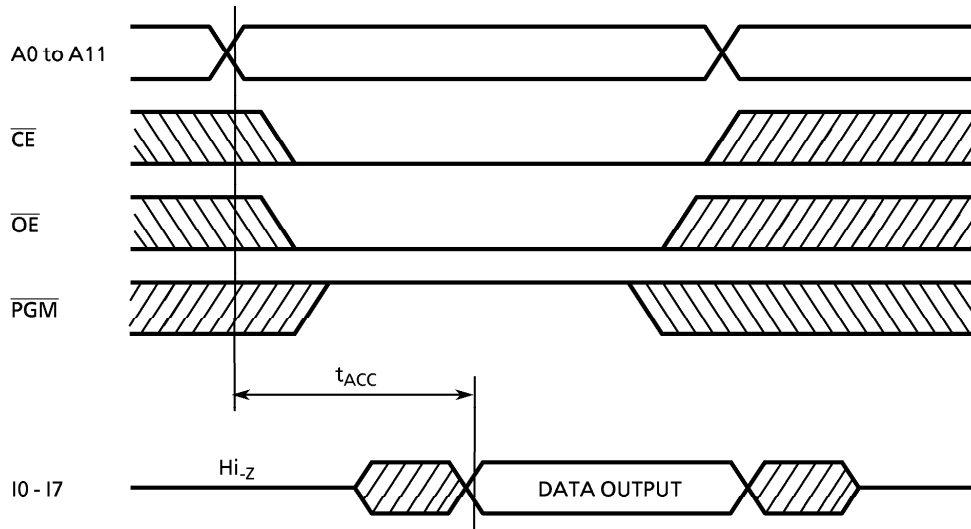

(2) High Speed Programming Operation

PARAMETER	SYMBOL	CONDITION	Min.	Typ.	Max.	UNIT
Input High Voltage	V_{IH4}		$V_{CC} \times 0.8$	-	V_{CC}	V
Input Low Voltage	V_{IL4}		0	-	$V_{CC} \times 0.1$	V
Supply Voltage	V_{CC}		4.75	-	6.0	V
V_{PP} Power Supply Voltage	V_{PP}		20.5	21.0	21.5	V
Programming Pulse Width	t_{PW}	$V_{CC} = 6.0 \pm 0.25$ V	0.95	1.0	1.05	ms

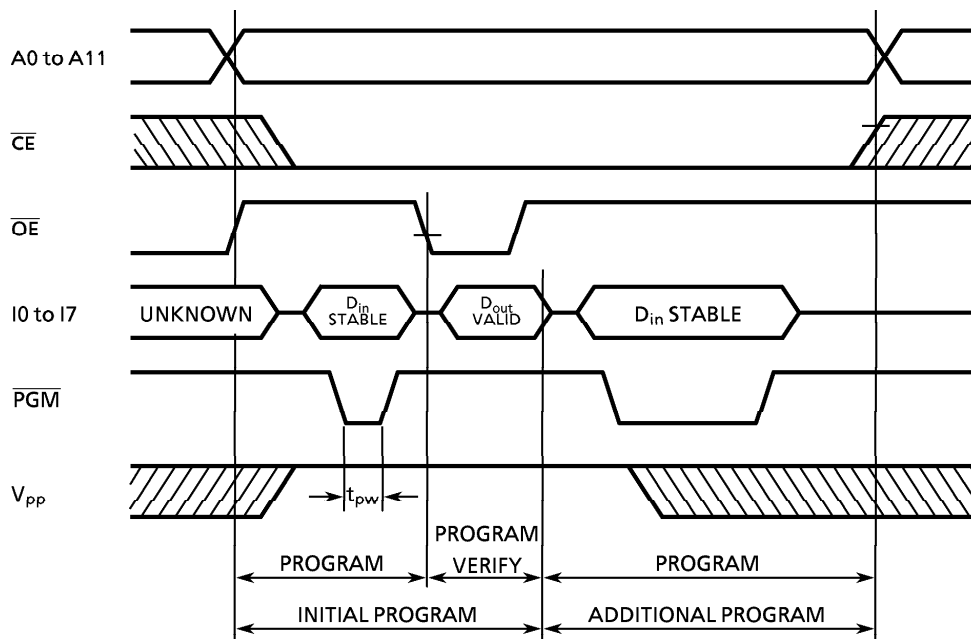

※ Difference compared with the TMP47C210A/410A
 The 47P410A is different from the 47C210A/410A with respect to the following spec points.

ABSOLUTE MAXIMUM RATINGS (V_{SS} = 0 V)

PARAMETER	SYMBOL	PINS		RATING	UNIT
		TMP47C210A/410A	TMP47P410A		
Output Voltage	V _{OUT1}	Except sink open drain pin	Except sink open drain pin, but include R8	- 0.3 to V _{DD} + 0.3	V
	V _{OUT2}	Sink open drain pin	The sink open drain pin except R8		

D. C. CHARACTERISTICS (V_{SS} = 0 V, T_{opr} = - 30 to 70 °C)

PARAMETER	SYMBOL	CONDITIONS	TMP47C210A/410A			TMP47P410A			UNIT
			Min.	Typ.	Max.	Min.	Typ.	Max.	
Supply Current	I _{DD}	In the Normal mode	—	3	6	—	5	10	mA

Note. Be fixed low level at MCU mode because of TEST pin does not have pull-down resistor.

TYPICAL CHARACTERISTICS

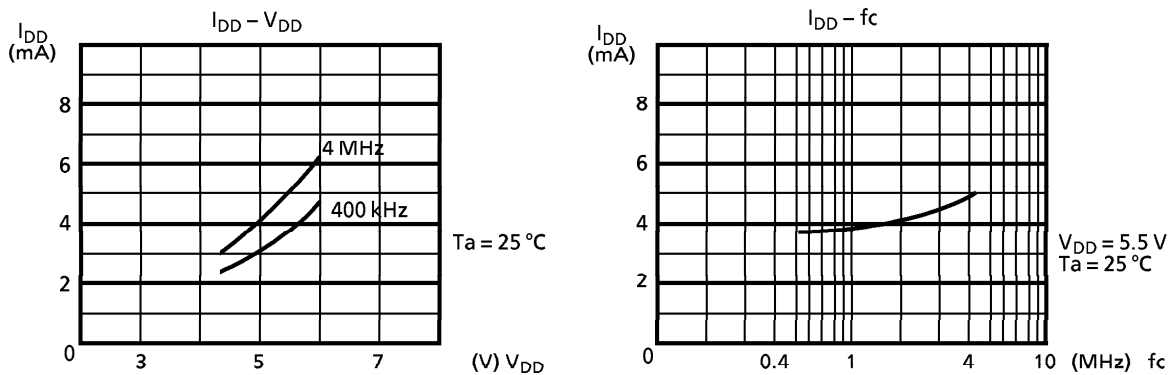

Note. When writing a program, set a ROM type to 2764 (programming voltage : 21V)
 Since the 47P410A has 4096 × 8 bit internal PROM (000 to FFF_H), set a stop address of a PROM writer to "FFF_H", or store the same data or "FF_H" to the latter half addresses 1000 to 1FFF_H.