

DATA SHEET

P83C562; P80C562 8-bit microcontroller

Product specification
File under Integrated Circuits, IC20

1997 Apr 16

8-bit microcontroller**P83C562; P80C562**

CONTENTS	13	SERIAL I/O
1	14	INTERRUPT SYSTEM
FEATURES	14.1	Interrupt Vectors
2	14.2	Interrupt priority
GENERAL DESCRIPTION	14.3	Interrupt Enable and Priority Registers
3	14.3.1	Interrupt Enable Register 0 (IEN0)
ORDERING INFORMATION	14.3.2	Interrupt Enable register 1 (IEN1)
4	14.3.3	Interrupt priority register 0 (IP0)
BLOCK DIAGRAM	14.3.4	Interrupt Priority Register 1 (IP1)
5	15	REDUCED POWER MODES
FUNCTIONAL DIAGRAM	15.1	Idle and Power-down operation
6	15.1.1	Idle mode
PINNING INFORMATION	15.1.2	Power-down mode
6.1	15.2	Power Control Register (PCON)
Pinning	16	OSCILLATOR CIRCUITRY
6.2	17	RESET CIRCUITRY
Pin description	17.1	Power-on-reset
7	18	INSTRUCTION SET
FUNCTIONAL DESCRIPTION	19	LIMITING VALUES
8	20	DC CHARACTERISTICS
MEMORY ORGANIZATION	21	AC CHARACTERISTICS
8.1	22	PACKAGE OUTLINES
Program Memory	23	SOLDERING
8.2	23.1	Introduction
Addressing	23.2	Reflow soldering
9	23.3	Wave soldering
I/O FACILITIES	23.4	Repairing soldered joints
10	24	DEFINITIONS
PULSE WIDTH MODULATED OUTPUTS	25	LIFE SUPPORT APPLICATIONS
10.1		
Prescaler Frequency Control Register (PWMP)		
10.2		
Pulse Width Register 0 (PWM0)		
10.3		
Pulse Width Register 1 (PWM1)		
11		
ANALOG-TO-DIGITAL CONVERTER (ADC)		
11.1		
Analog input pins		
11.2		
ADC Control Register (ADCON)		
12		
TIMER/ COUNTERS		
12.1		
Timer 0 and Timer 1		
12.2		
Timer T2 Capture and Compare Logic		
12.2.1		
T2 Control Register (TM2CON)		
12.2.2		
Capture Control Register (CTCON)		
12.2.3		
Interrupt Flag Register (TM2IR)		
12.2.4		
Set Enable Register (STE)		
12.2.5		
Reset/Toggle Enable register (RTE)		
12.3		
Watchdog Timer (T3)		

8-bit microcontroller

P83C562; P80C562

1 FEATURES

- 80C51 Central Processing Unit
- 8 kbytes ROM, expandable externally to 64 kbytes
- 256 bytes RAM, expandable externally to 64 kbytes
- Two standard 16-bit timer/counters
- An additional 16-bit timer/counter coupled to four capture registers and three compare registers
- An 8-bit ADC with 8 multiplexed analog inputs
- Two 8-bit resolution, Pulse Width Modulated outputs
- Five 8-bit I/O ports plus one 8-bit input port shared with analog inputs
- Full-duplex UART compatible with the standard 80C51
- On-chip Watchdog Timer
- Oscillator frequency: 3.5 to 16 MHz.

2 GENERAL DESCRIPTION

The P80C562/P83C562 (hereafter generally referred to as P8xC562) single-chip 8-bit microcontroller is manufactured in an advanced CMOS process and is a derivative of the 80C51 microcontroller family.

The P8xC562 has the same instruction set as the 80C51. Two versions of the derivative exist:

- With 8 kbytes mask-programmable ROM
- ROMless version of the P8xC562.

3 ORDERING INFORMATION

TYPE NUMBER	PACKAGE			FREQUENCY RANGE (MHz)	TEMPERATURE RANGE (°C)
	NAME	DESCRIPTION	VERSION		
P80CE562EHA ⁽¹⁾	PLCC68	plastic leaded chip carrier; 68 leads	SOT188-2	3.5 to 16	-40 to +125
P80C562EBA ⁽¹⁾					0 to +70
P80C562EFA ⁽¹⁾					-40 to +85
P83C562EHA/nnn ⁽²⁾					-40 to +125
P83C562EBA/nnn ⁽²⁾					0 to +70
P83C562EFA/nnn ⁽²⁾					-40 to +85

Notes

1. ROMless type.
2. ROM coded type; nnn denotes the ROM code number.

This I/O intensive device provides architectural enhancements to function as a controller in the field of automotive electronics, specifically engine management and gear box control.

The P8xC562 contains a non-volatile 8 kbyte read only program memory, a volatile 256 byte read/write data memory, six 8-bit I/O ports, two 16-bit timer/event counters (identical to the timers of the 80C51), an additional 16-bit timer coupled to capture and compare latches, a fourteen-source, two-priority-level, nested interrupt structure, an 8-input ADC, a dual DAC with pulse width modulated outputs, a serial interface (UART), a Watchdog Timer and on-chip oscillator and timing circuits. For systems that require extra capability, the P8xC562 can be expanded using standard TTL compatible memories and logic.

The device also functions as an arithmetic processor having facilities for both binary and BCD arithmetic plus bit-handling capabilities. The instruction set consists of over 100 instructions: 49 one-byte, 45 two-byte and 17 three-byte. With a 16 MHz crystal, 58% of the instructions are executed in 0.75 μ s and 40% in 1.5 μ s. Multiply and divide instructions require 3 μ s.

8-bit microcontroller

P83C562; P80C562

4 BLOCK DIAGRAM

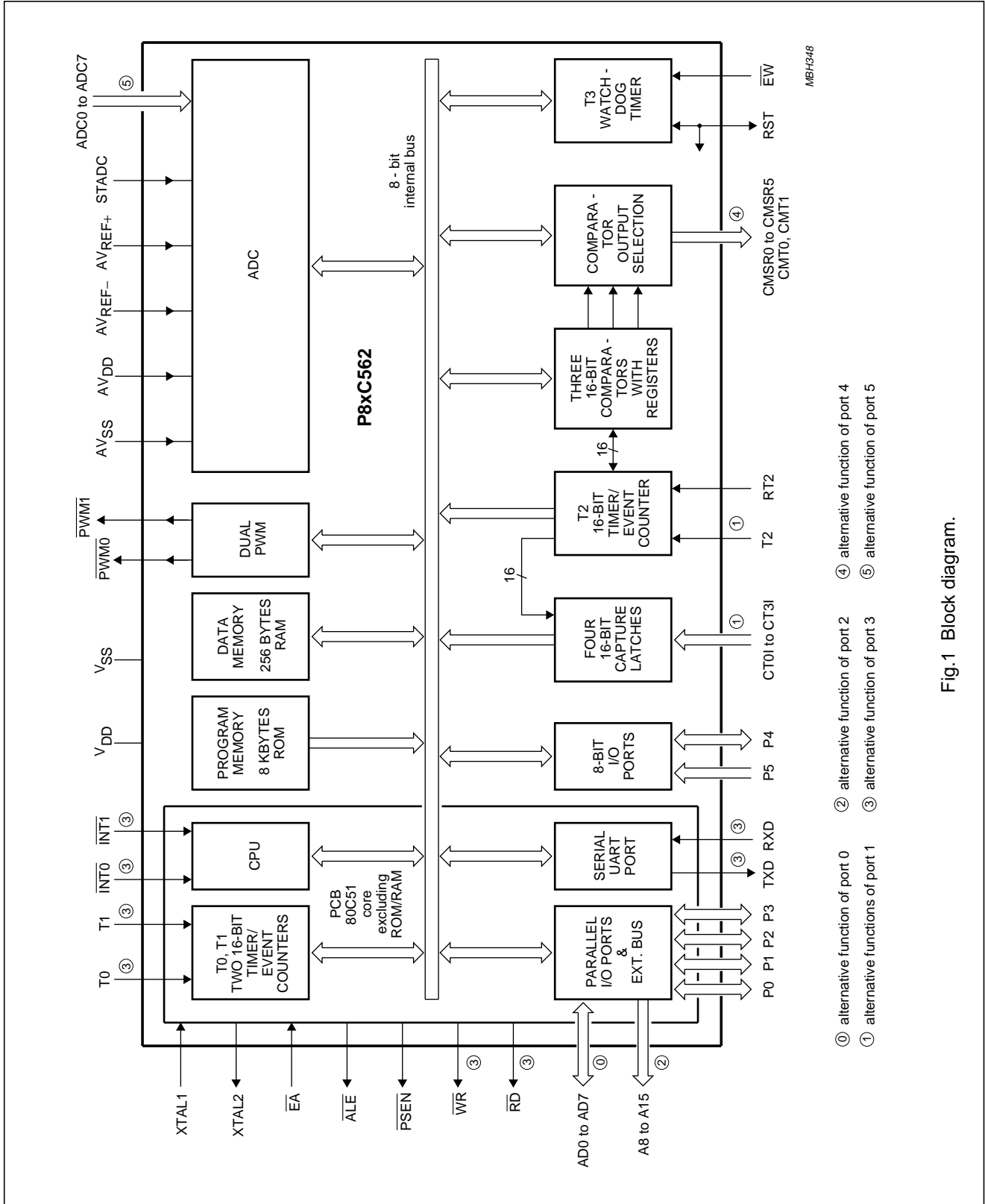

Fig.1 Block diagram.

8-bit microcontroller

P83C562; P80C562

5 FUNCTIONAL DIAGRAM

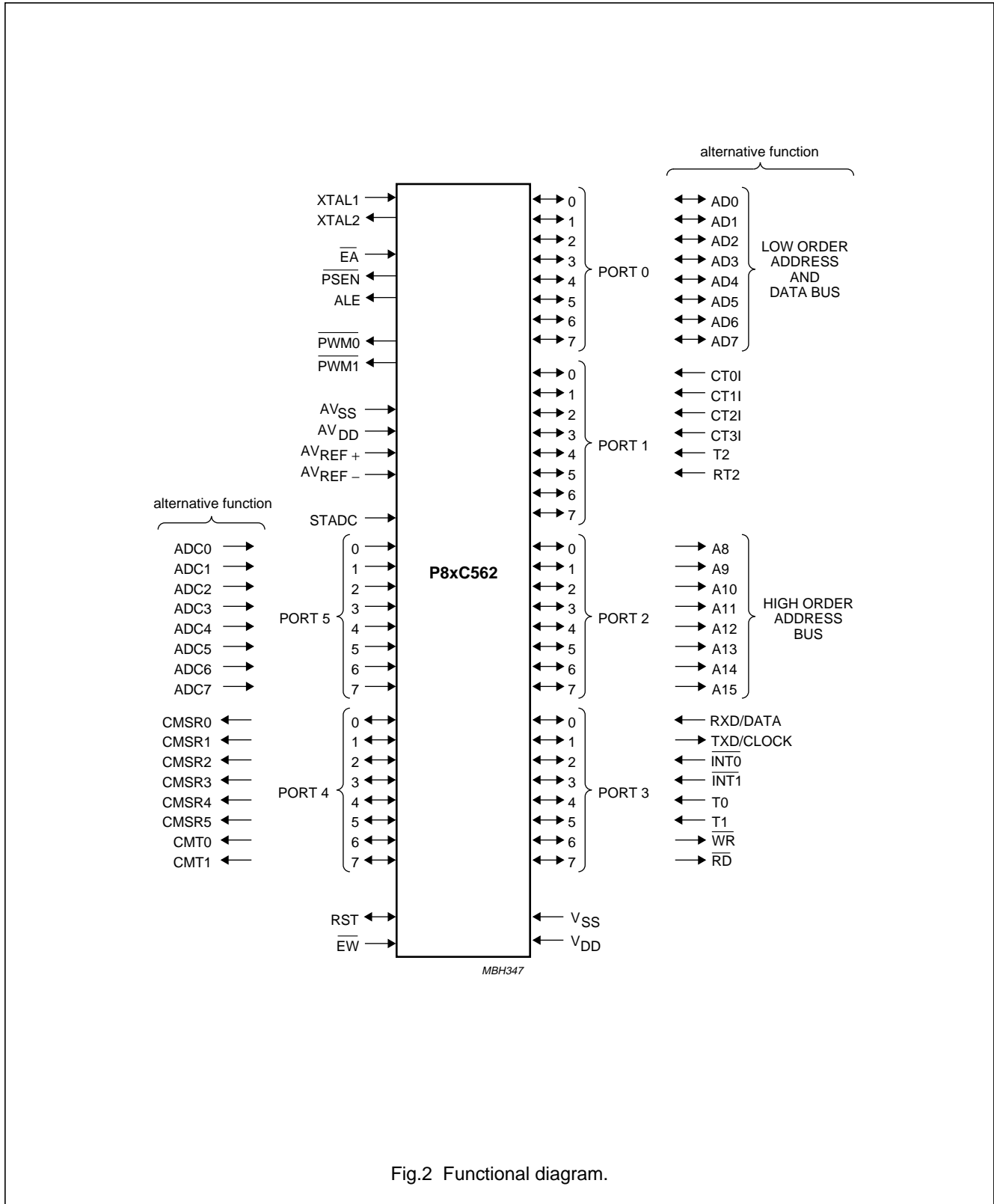

Fig.2 Functional diagram.

8-bit microcontroller

P83C562; P80C562

6 PINNING INFORMATION

6.1 Pinning

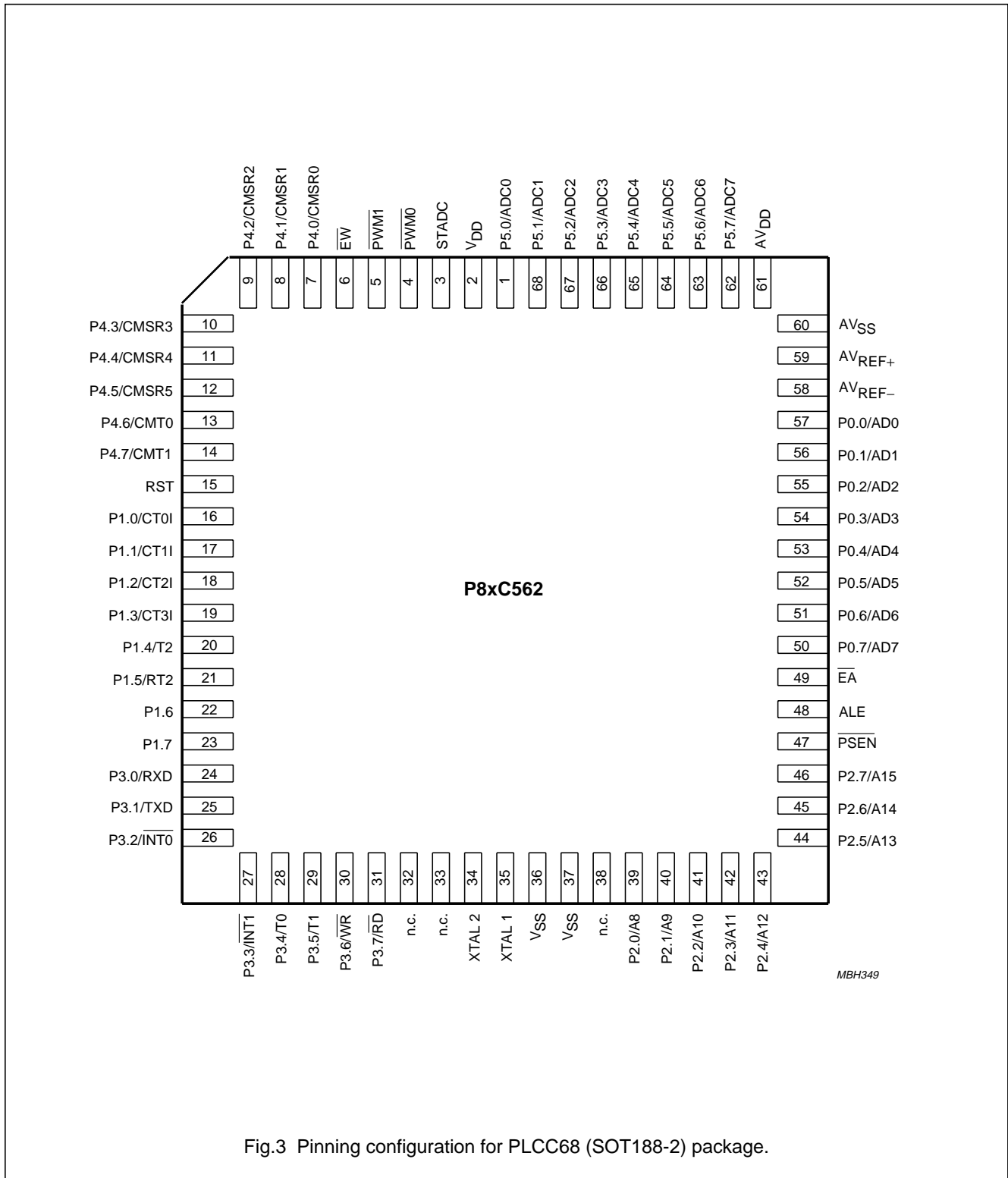

Fig.3 Pinning configuration for PLCC68 (SOT188-2) package.

8-bit microcontroller

P83C562; P80C562

6.2 Pin description

Table 1 PLCC68 (SOT188-2)

To avoid latch-up at Power-on, the voltage at any pin at any time must lie within the range $V_{DD} + 0.5\text{ V}$ to $V_{SS} - 0.5\text{ V}$.

SYMBOL	PIN	DESCRIPTION
V_{DD}	2	Power supply , digital part (+5 V). Power supply pins during normal operation and power reduction modes.
STADC	3	Start ADC operation : Input starting analog-to-digital conversion (ADC operation can also be started by software). This pin must not float.
$\overline{\text{PWM0}}$	4	Pulse Width Modulation output 0 .
$\overline{\text{PWM1}}$	5	Pulse Width Modulation output 1 .
$\overline{\text{EW}}$	6	Enable Watchdog Timer : enable for Watchdog Timer and disable Power-down mode. This pin must not float.
P4.0/CMSR0 to P4.5/CMSR5	7 to 12	P4.0 to P4.5 : 8-bit quasi-bidirectional I/O port lines; CMSR0 to CMSR5 : Compare and Set/Reset outputs for Timer T2.
P4.6/CMT0	13	P4.6 to P4.7 : 8-bit quasi-bidirectional I/O port lines; CMT0 to CMT1 : Compare and toggle outputs for Timer T2.
P4.7/CMT1	14	
RST	15	Reset : Input to reset the P8x562; also generated when the Watchdog Timer overflows.
P1.0/CT0I to P1.3/CT3I	16 to 19	P1.0 to P1.3 : 8-bit quasi-bidirectional I/O port lines; CT0I to CT3I : Capture timer inputs for Timer 2.
P1.4/T2	20	P1.4 : 8-bit quasi-bidirectional I/O port line; T2 : T2 event input (rising edge triggered).
P1.5/RT2	21	P1.5 : 8-bit quasi-bidirectional I/O port line; RT2 : T2 timer reset input (rising edge triggered)
P1.6 to P1.7	22 to 23	P1.6 to P1.7 : 8-bit quasi-bidirectional I/O port lines, open-drain.
P3.0/RXD	24	P3.0 : 8-bit quasi-bidirectional I/O port line; RXD : Serial input port.
P3.1/TXD	25	P3.1 : 8-bit quasi-bidirectional I/O port line; TXD : Serial output port.
P3.2/ $\overline{\text{INT0}}$	26	P3.2 : 8-bit quasi-bidirectional I/O port line; INT0 : External interrupt input 0.
P3.3/ $\overline{\text{INT1}}$	27	P3.3 : 8-bit quasi-bidirectional I/O port line; INT1 : External interrupt input 1.
P3.4/T0	28	P3.4 : 8-bit quasi-bidirectional I/O port line; T0 : Timer 0 external input.
P3.5/T1	29	P3.5 : 8-bit quasi-bidirectional I/O port line; T1 : Timer 1 external input.
P3.6/ $\overline{\text{WR}}$	30	P3.6 : 8-bit quasi-bidirectional I/O port line; WR : External Data Memory Write strobe.
P3.7/ $\overline{\text{RD}}$	31	P3.7 : 8-bit quasi-bidirectional I/O port line; RD : External Data Memory Read strobe.
n.c.	32, 33	Not connected.
XTAL2	34	Crystal Oscillator Output : output of the inverting amplifier that forms the oscillator. Left open-circuit when an external oscillator clock is used.

8-bit microcontroller

P83C562; P80C562

SYMBOL	PIN	DESCRIPTION
XTAL1	35	Crystal Oscillator Input: input to the inverting amplifier that forms the oscillator, and input to the internal clock generator. Receives the external oscillator clock signal when an external oscillator is used.
V _{SS}	36, 37	Digital ground pins.
n.c.	38	Not connected.
P2.0/A08 to P2.7/A15	39 to 46	P2.0 to P2.7: 8-bit quasi-bidirectional I/O port lines; A08 to A15: High-order address byte for external memory.
PSEN	47	Program Store Enable: read strobe to the external program memory via Port 0 and 2. Is activated twice each machine cycle during fetches from external program memory. When executing out of external program memory two activations of PSEN are skipped during each access to external data memory. PSEN is not activated (remains HIGH) during no fetches from external program memory. PSEN can sink/source 8 LSTTL inputs and can drive CMOS inputs without external pull-ups.
ALE	48	Address Latch Enable: latches the low byte of the address during access of external memory in normal operation. It is activated every six oscillator periods except during an external data memory access. ALE can sink/source 8 LSTTL inputs and can drive CMOS inputs without an external pull-up. To prohibit the toggling of the ALE pin (RFI noise reduction) the RFI bit in the Power Control Register must be set by software.
\overline{EA}	49	External Access: if, during RESET, \overline{EA} is HIGH the CPU executes out of the internal program memory provided the program Counter is less than 8192. If, during RESET, \overline{EA} is LOW the CPU executes out of external program memory via Port 0 and Port 2. \overline{EA} is not allowed to float. \overline{EA} is latched during RESET and don't care after RESET.
P0.7/AD7 to P0.0/AD0	50 to 57	P0.7 to P0.0: 8-bit open drain bidirectional I/O port lines; AD7 to AD0: Multiplexed Low-order address and Data bus for external memory.
AV _{REF-}	58	Low-end of ADC (analog-to-digital conversion) reference resistor.
AV _{REF+}	59	High-end of ADC (analog-to-digital conversion) reference resistor.
AV _{SS}	60	Ground , analog part. For ADC receiver and reference voltage.
AV _{DD}	61	Power supply , analog part (+5 V). For ADC receiver and reference voltage.
P5.7/ADC7 to P5.0/ADC0	62 to 68, 1	P5.7 to P5.0: 8-bit input port lines; ADC7 to ADC0: eight analog ADC inputs

8-bit microcontroller

P83C562; P80C562

7 FUNCTIONAL DESCRIPTION

The P8xC562 is a stand-alone high-performance microcontroller designed for use in real-time applications such as instrumentation, industrial control and specific automotive control applications.

In addition to the 80C51 standard functions, the device provides a number of dedicated hardware functions for these applications.

The P8xC562 is a control-oriented CPU with on-chip program and data memory. It can be extended with external program memory up to 64 kbytes. It can also access up to 64 kbytes of external data memory. For systems requiring extra capability, the P8xC562 can be expanded using standard memories and peripherals.

The P8xC562 has two software selectable modes of reduced activity for further power reduction – Idle and Power-down. The Idle mode freezes the CPU while allowing the RAM, timers, serial ports and interrupt system to continue functioning. The Power-down mode saves the RAM contents but freezes the oscillator causing all other chip functions to be inoperative.

8 MEMORY ORGANIZATION

The Central Processing Unit (CPU) manipulates operands in three memory spaces; these are the 64 kbyte external data memory, 256 byte internal data memory and the 64 kbyte internal and external program memory. The internal data memory is divided into 3 sections: the lower 128 bytes of RAM, the upper 128 bytes of RAM and the 128 byte Special Function Register memory (see Fig.4). Figure 5 shows the Special Function Registers memory map. Internal RAM locations 0 to 127 are directly and indirectly addressable. Internal RAM locations 128 to 155 are only indirectly addressable. The Special Function Register locations 128 to 255 are only directly addressable.

The internal data RAM contains four register banks (each with eight registers), 128 addressable bits, a scratch pad area and the stack. The stack depth is limited by the available internal data RAM and its location is determined by the 8-bit Stack Pointer. All registers except the Program Counter and the four 8-register banks reside in the Special Function Register address space. These memory mapped registers include arithmetic registers, pointers, I/O ports, interrupt system registers, ADC and PWM registers, timers and serial port registers. There are 120 addressable bit locations in the SFR address space.

The P8xC562 contains 256 bytes of internal data RAM and 52 Special Function Registers. It provides a non-paged program memory address space to accommodate relocatable code. Conditional branches are performed relative to the Program Counter.

The register-indirect jump permits branching relative to a 16-bit base register with an offset provided by an 8-bit index register. 16-bit jumps and calls permit branching to any location in the contiguous 64 kbyte program memory address space.

8.1 Program Memory

The program memory address space of the P83C562 consists of internal and external memory. The P83C562 has 8 kbytes of program memory on-chip. The program memory can be externally expanded up to 64 kbytes. If the \overline{EA} pin is held HIGH, the P83C562 executes out of the internal program memory unless the address exceeds 1FFFH then locations 2000H through to 0FFFFH are fetched from the external program memory. If the \overline{EA} pin is held LOW, the P83C562 fetches all instructions from the external memory. Figure 4 illustrates the program memory address space.

By setting a mask programmable security bit (i.e. user dependent) the ROM content is protected i.e. it cannot be read at any time by any test mode or by any instruction in the external program memory space. The MOVC instructions are the only ones which have access to program code in the internal or external program memory. The \overline{EA} input is latched during reset and is 'don't care' after reset. This implementation prevents from reading internal program code by switching from the external program memory to internal program memory during MOVC instruction or an instruction that handles immediate data. Table 2 lists the access to internal and external program memory by the MOVC instructions when the security bit has been set to a logic 1. If the security bit has been set to a logic 0 there are no restrictions for the MOVC instructions.

Table 2 Memory access by the MOVC instruction

MOVC INSTRUCTION	PROGRAM MEMORY ACCESS	
	INTERNAL	EXTERNAL
MOVC in internal program memory	YES	YES
MOVC in external program memory	NO	YES

8-bit microcontroller

P83C562; P80C562

8.2 Addressing

The P8xC562 has five methods for addressing source operands:

- Register
- Direct
- Register-Indirect
- Immediate
- Base-Register plus Index-Register-Indirect.

The first three methods can be used for addressing destination operands. Most instructions have a 'destination/source' field that specifies the data type, addressing methods and operands involved. For operations other than MOVs, the destination operand is also a source operand.

Access to memory addressing is as follows:

- Registers in one of the four 8-register banks through Register, Direct or Register-Indirect

- 256 bytes of internal data RAM through Direct or Register-Indirect. Bytes 0 to 127 may be addressed directly/indirectly. Bytes 128 to 155 share their address locations with the SFR registers and so may only be addressed indirectly as data RAM
- Special Function Registers through Direct at address locations 128 to 255
- External data memory through Register-Indirect
- Program memory look-up tables through Base-Register plus Index-Register-Indirect.

The P8xC562 is classified as an 8-bit device since the internal ROM, RAM, Special Function Registers, Arithmetic Logic Unit and external data bus are all 8-bits wide. It performs operations on bit, nibble, byte and double-byte data types.

Facilities are available for byte transfer, logic and integer arithmetic operations. Data transfer, logic and conditional branch operations can be performed directly on Boolean variables to provide excellent bit handling.

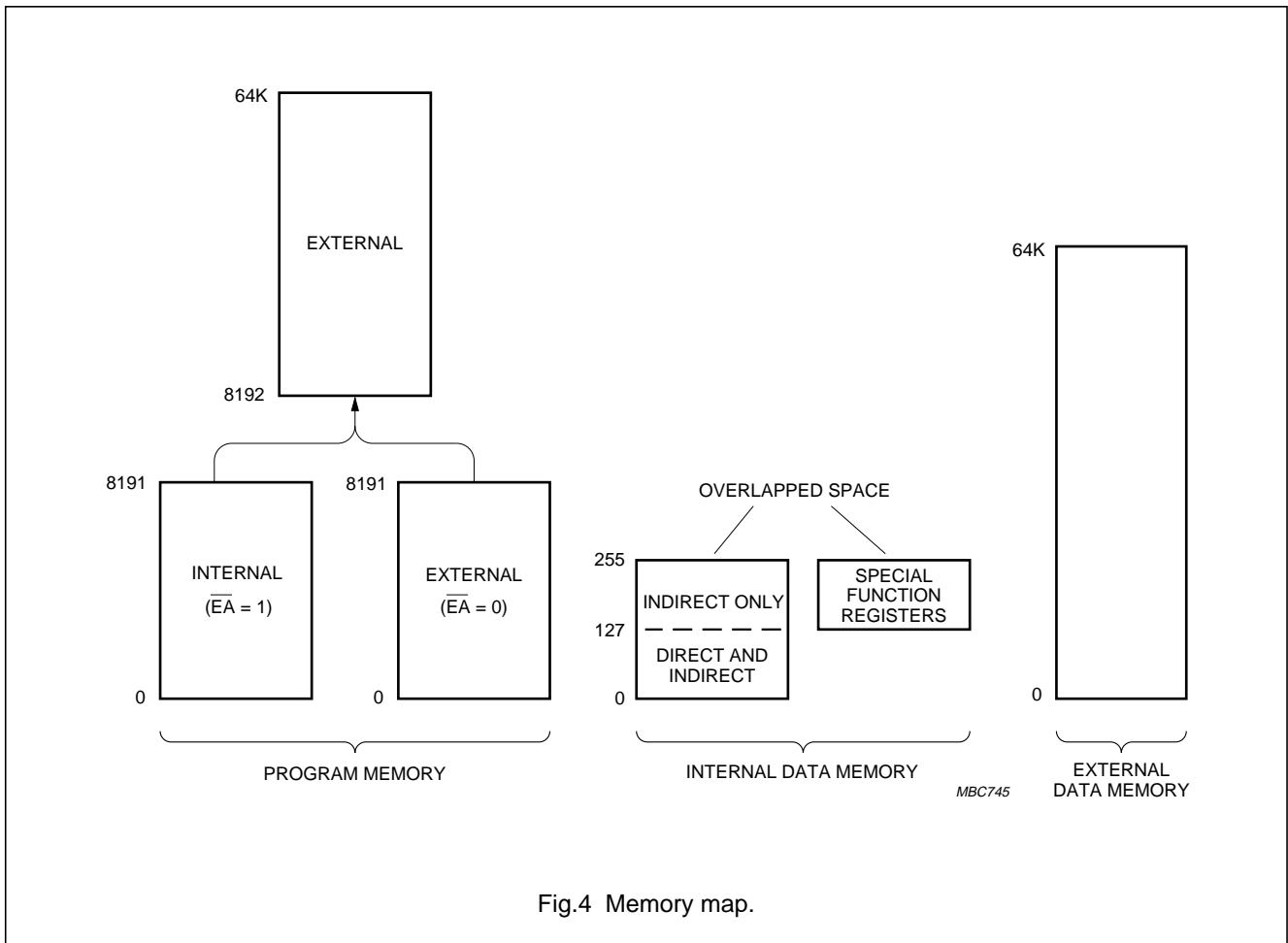

Fig.4 Memory map.

8-bit microcontroller

P83C562; P80C562

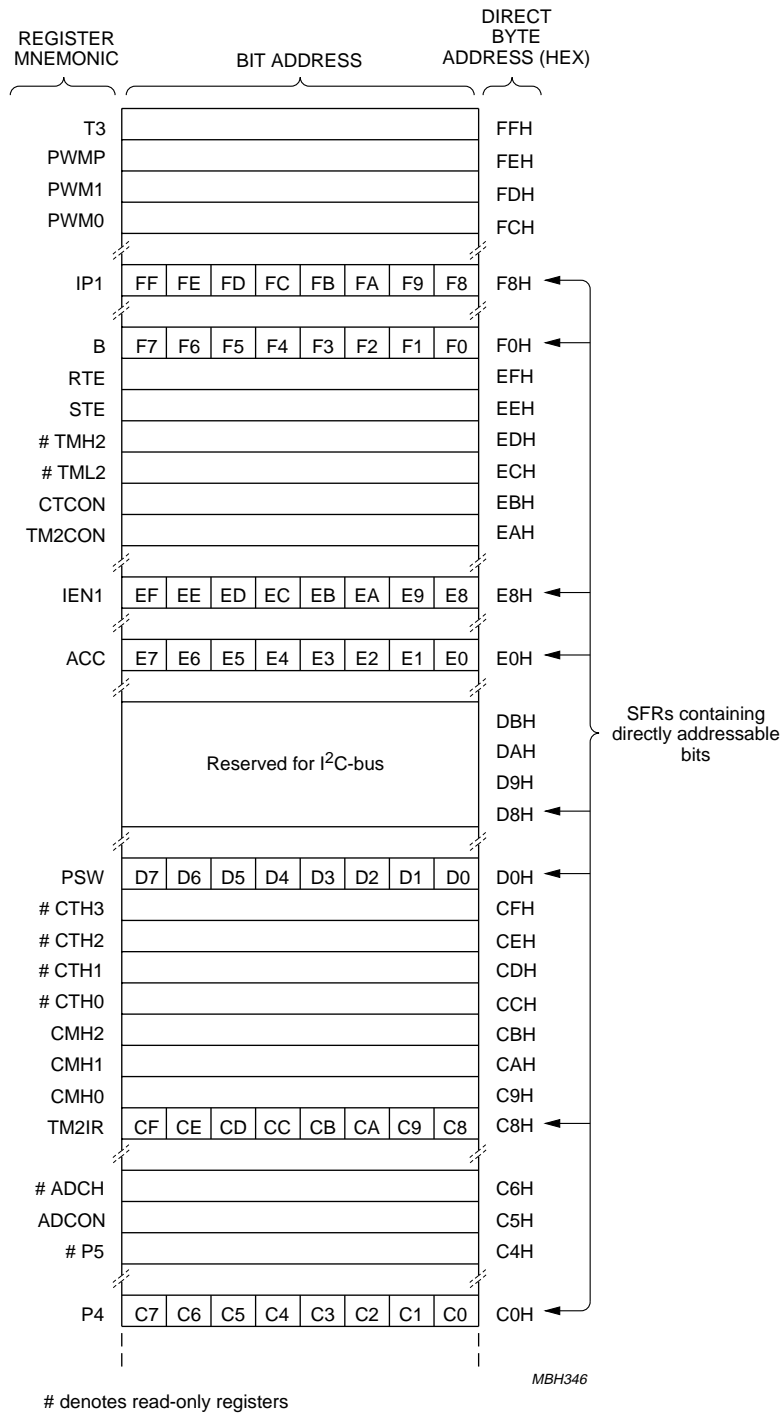

Fig.5 Special Function Register memory map.

8-bit microcontroller

P83C562; P80C562

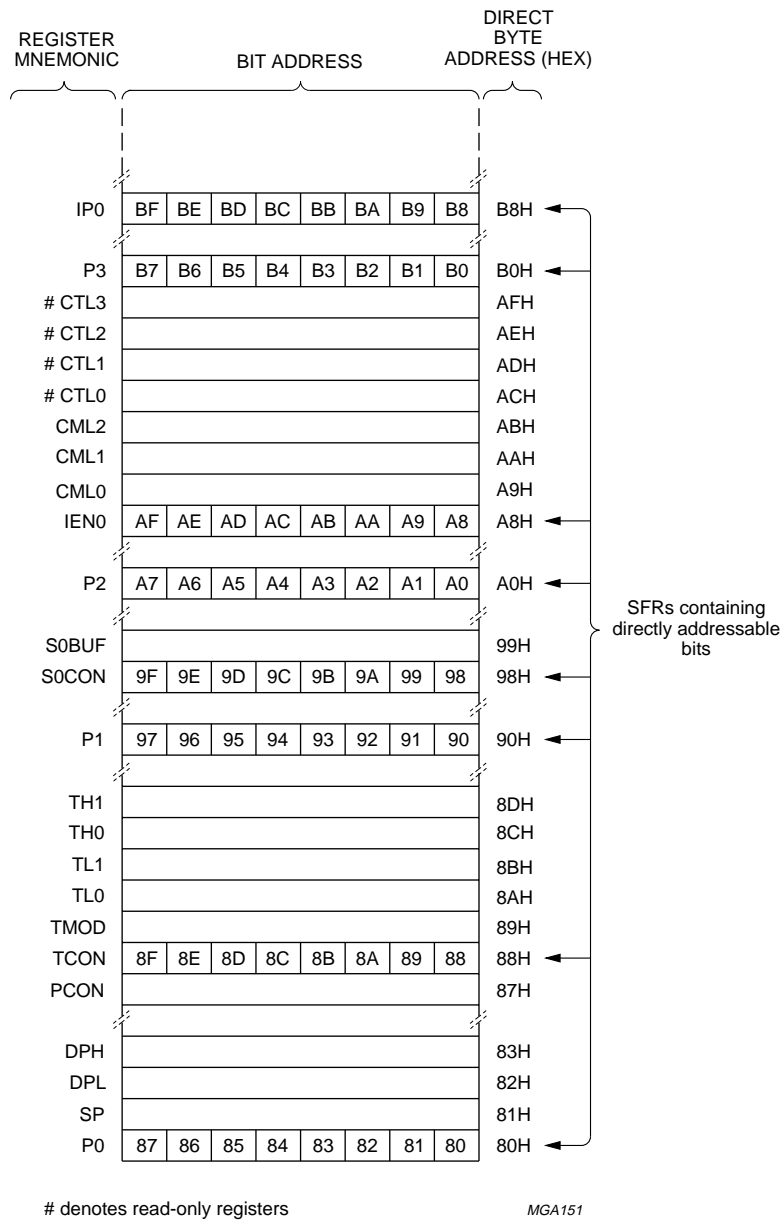

Fig.6 Special Function Register memory map (continued).

8-bit microcontroller

P83C562; P80C562

9 I/O FACILITIES

The P8xC562 has six 8-bit ports. Ports 0 to 3 are the same as in the 80C51, with the exception of the additional functions of Port 1. The parallel I/O function of Port 4 is equal to that of Ports 1, 2 and 3. Port 5 has a parallel input port function, but has no function as an output port.

Ports 0 to 5 perform the following alternative functions:

Port 0 Provides the multiplexed low-order address and data bus used for expanding the P8xC562 with standard memories and peripherals.

Port 1 is used for a number of special functions:

- 4 capture inputs (or external interrupt request inputs if capture information is not utilized)
- External counter input
- External counter reset input.

Port 2 Provides the high-order address bus when expanding the P8xC562 with external program memory and/or external data memory.

Port 3 Pins can be configured individually to provide:

- External interrupt request inputs
- Counter inputs
- Serial port receiver input and transmitter output
- Control signals to READ and WRITE external data memory.

Port 4 Can be configured to provide signals indicating a match between timer counter T2 and its compare registers.

Port 5 May be used in conjunction with the ADC interface. Unused analog inputs can be used as digital inputs. As Port 5 lines may be used as inputs to the ADC, these digital inputs have an inherent hysteresis to prevent the input logic from drawing too much current from the power lines when driven by analog signals. Channel-to-channel crosstalk should be taken into consideration when both digital and analog signals are simultaneously input to Port 5 (see Chapter 20).

All ports are bidirectional with the exception of Port 5 which is an input port. Alternative function bits which are not used may be used as normal bidirectional I/O pins.

The generation or use of a Port 1, Port 3 or Port 4 pin as an alternative function is carried out automatically by the P8xC562 provided the associated Special Function Register bit is set HIGH.

In addition to the standard 8-bit ports, the I/O facilities of the P8xC562 also include a number of special I/O lines.

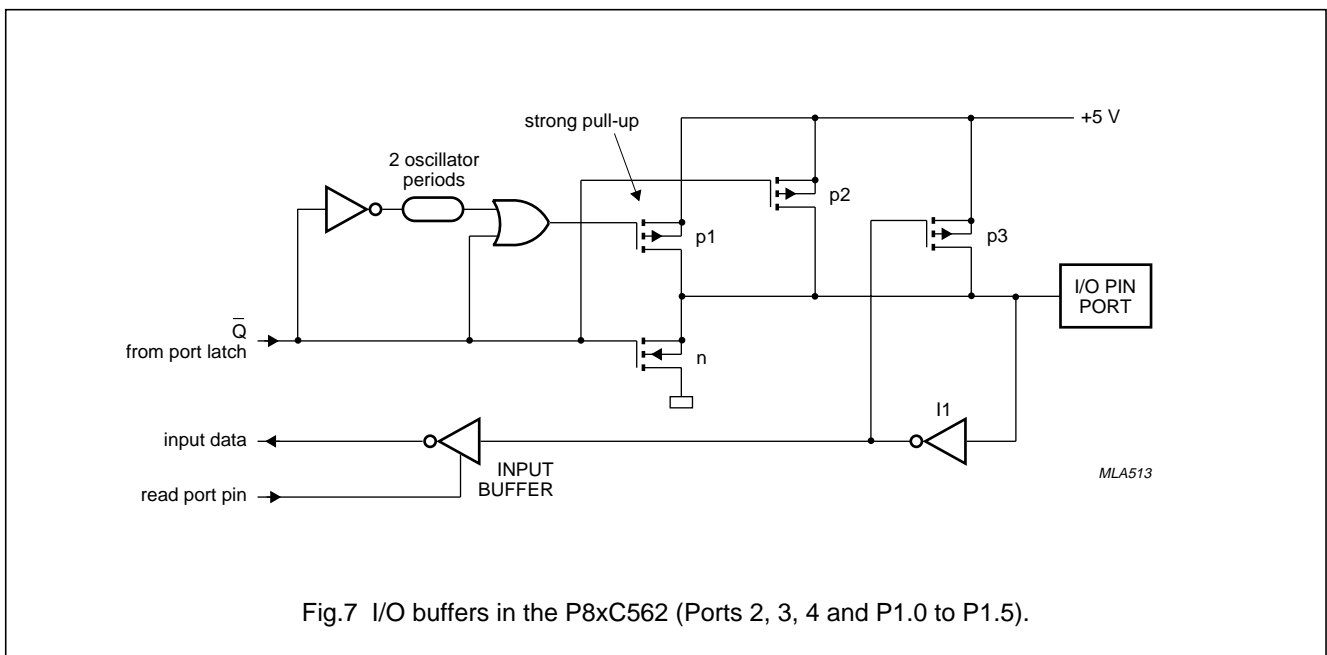

Fig.7 I/O buffers in the P8xC562 (Ports 2, 3, 4 and P1.0 to P1.5).

8-bit microcontroller

P83C562; P80C562

10 PULSE WIDTH MODULATED OUTPUTS

Two pulse width modulated output channels are provided with the P8x562. These channels output pulses of programmable length and interval. The repetition frequency is defined by an 8-bit prescaler PWMP which generates the clock for the counter. Both the prescaler and counter are common to both PWM channels. The 8-bit counter counts modulo 255 i.e. from 0 to 254 inclusive. The value of the 8-bit counter is compared to the contents of two registers: PWM0 and PWM1.

Provided the contents of either of these registers is greater than the counter value, the output of PWM0 or PWM1 is set LOW. If the contents of these registers are equal to, or less than the counter value, the output will be HIGH. The pulse width ratio is therefore defined by the contents of the registers PWM0 and PWM1.

The pulse width ratio is in the range of 0 to 255/255 and may be programmed in increments of 1/255.

The repetition frequency f_{PWM} , at the PWMn outputs is

$$f_{PWM} = \frac{f_{osc}}{2 \times (1 + PWMP) \times 255}$$

When using an oscillator frequency of 16 MHz for example, the above formula would give a repetition frequency range of 123 Hz to 31.4 kHz.

By loading the PWM registers with either 00H or FFH, the PWM outputs can be retained at a constant HIGH or LOW level respectively. When loading FFH to the PWM registers, the 8-bit counter will never actually reach this value. Both PWMn output pins are driven by push-pull drivers, and are not shared with any other function.

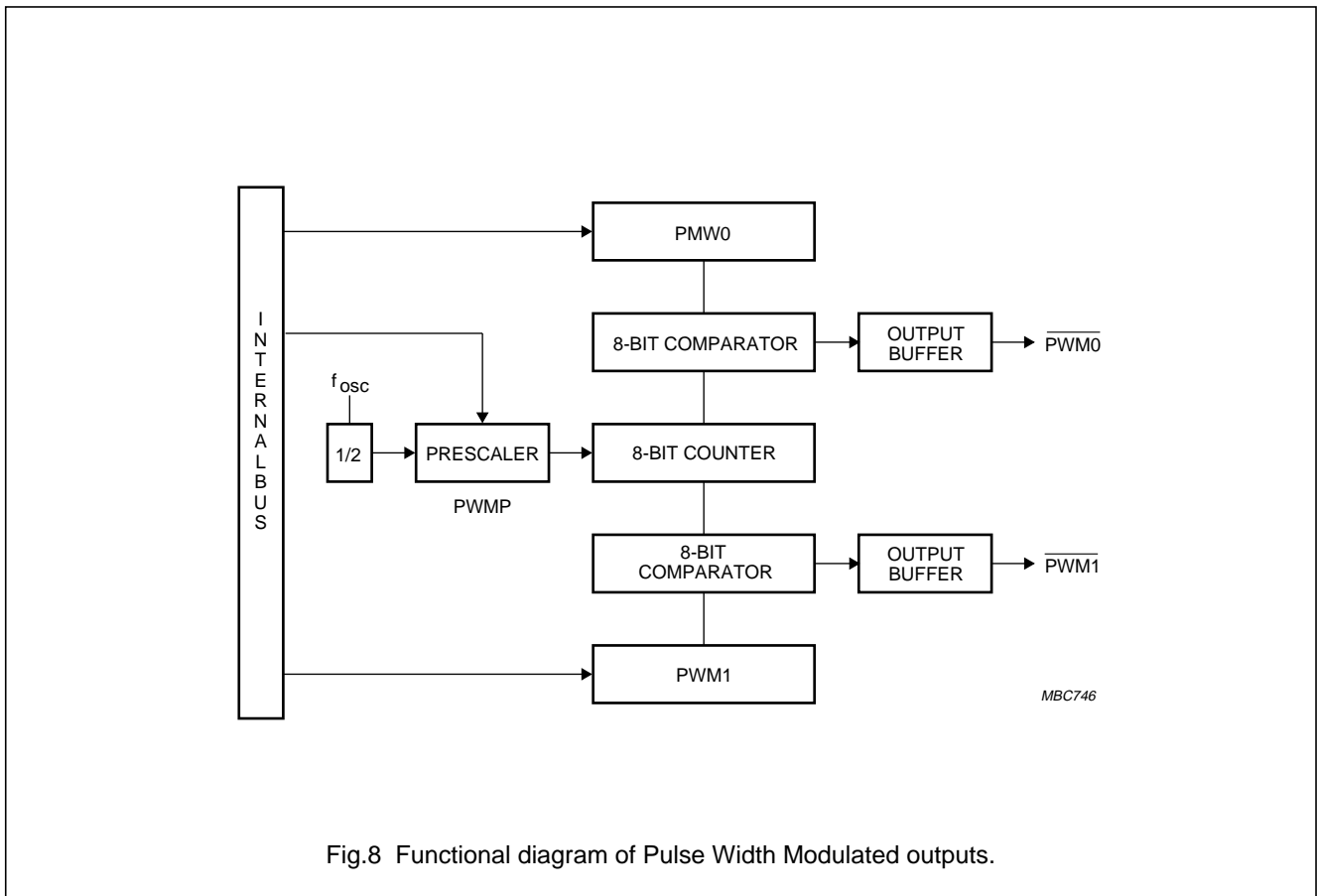

Fig.8 Functional diagram of Pulse Width Modulated outputs.

8-bit microcontroller

P83C562; P80C562

10.1 Prescaler Frequency Control Register (PWMP)**Table 3** Prescaler Frequency Control Register (SFR address FEH)

7	6	5	4	3	2	1	0
PWMP.7	PWMP.6	PWMP.5	PWMP.4	PWMP.3	PWMP.2	PWMP.1	PWMP.0

Table 4 Description of PWMP bits

BIT	SYMBOL	DESCRIPTION
7 to 0	PWMP.7 to PWMP.0	Prescaler division factor. The prescaler division factor = (PWMP) + 1.

10.2 Pulse Width Register 0 (PWM0)**Table 5** Pulse Width Register 0 (SFR address FCH)

7	6	5	4	3	2	1	0
PWM0.7	PWM0.6	PWM0.5	PWM0.4	PWM0.3	PWM0.2	PWM0.1	PWM0.0

Table 6 Description of PWM0 bits

BIT	SYMBOL	DESCRIPTION
7 to 0	PWM0.7 to PWM0.0	Pulse width ratio. LOW/HIGH ratio of $\overline{\text{PWMn}}$ signals = $\frac{(\text{PWMn})}{255 - (\text{PWMn})}$

10.3 Pulse Width Register 1 (PWM1)**Table 7** Pulse Width Register 1 (SFR address FDH)

7	6	5	4	3	2	1	0
PWM1.7	PWM1.6	PWM1.5	PWM1.4	PWM1.3	PWM1.2	PWM1.1	PWM1.0

Table 8 Description of PWM1 bits

BIT	SYMBOL	DESCRIPTION
7 to 0	PWM1.7 to PWM1.0	Pulse width ratio. LOW/HIGH ratio of $\overline{\text{PWMn}}$ signals = $\frac{(\text{PWMn})}{255 - (\text{PWMn})}$

8-bit microcontroller

P83C562; P80C562

11 ANALOG-TO-DIGITAL CONVERTER (ADC)

The completion of the 8-bit ADC conversion is flagged by ADCI in the ADCON register and the result is stored in Special Function Register ADCH.

An ADC conversion in progress is unaffected by an external or software ADC start. The result of a completed conversion remains unaffected provided ADCI = 1. While ADCS = 1 or ADCI = 1, a new ADC start will be blocked and consequently lost.

An ADC conversion already in progress is aborted when the Idle or Power-down mode is entered. The result of a completed conversion (ADCI = 1) remains unaffected when entering the Idle mode.

If ADCI is cleared by software and ADCS is set at the same time, a new analog-to-digital conversion with the same channel number, may be started. However, it is recommended to reset ADCI before ADCS is set.

11.1 Analog input pins

The analog input circuitry consists of an 8-input analog multiplexer and an ADC with 8-bit resolution. The analog reference voltage and analog power supplies are connected via separate input pins. The conversion takes 24 machine cycles i.e. 18 μ s at an oscillator frequency of 16 MHz.

The ADC is controlled using the ADC Control Register (ADCON). Input channels are selected by the analog multiplexer, using bits AADR.0 to AADR.2 in ADCON.

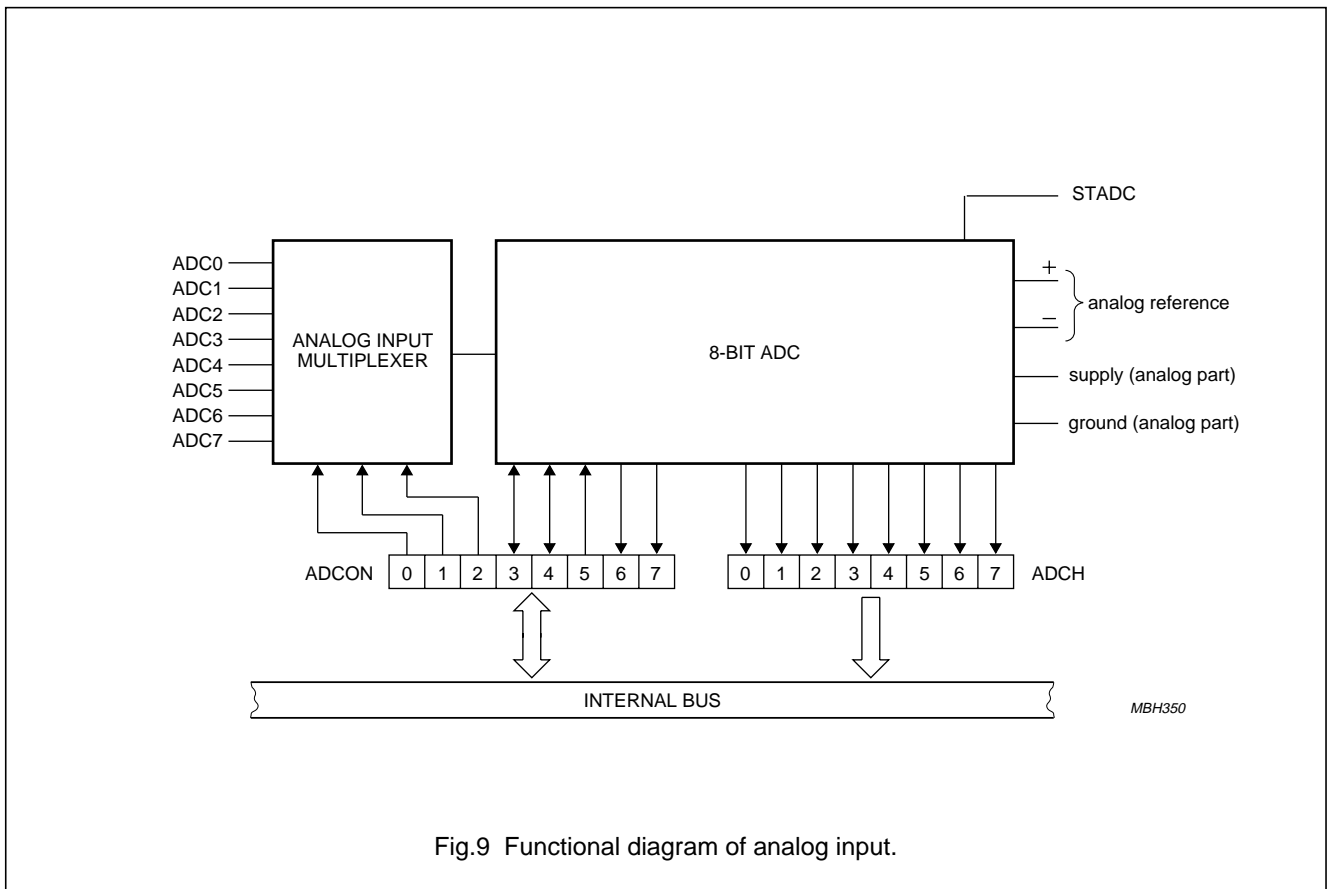

Fig.9 Functional diagram of analog input.

8-bit microcontroller

P83C562; P80C562

11.2 ADC Control Register (ADCON)

Table 9 ADC Control Register (SFR address C5H)

7	6	5	4	3	2	1	0
–	–	ADEX	ADCI	ADCS	AADR2	AADR1	AADR0

Table 10 Description of ADCON bits

BIT	SYMBOL	DESCRIPTION
7	–	These two bits are reserved.
6	–	
5	ADEX	Enable external start: start of conversion by STADC. If ADEX = 0, then conversion can not be started externally by STADC (only by software by setting ADCS). If ADEX = 1, then conversion can be started externally by a rising edge on STADC or by software.
4	ADCI	ADC interrupt flag: this flag is set when an analog-to-digital conversion result is ready to be read. An interrupt is invoked if it is enabled. The flag must be cleared by the interrupt service routine. While this flag is set, the ADC cannot start a new conversion. ADCI cannot be set by software.
3	ADCS	ADC start and status: setting this bit starts an ADC conversion. It may be set by software or by the external signal STADC. The ADC logic ensures that this signal is HIGH while the ADC is busy. On completion of the conversion, ADCS is reset immediately after the interrupt flag has been set. ADCS can not be reset by software nor can a new conversion be started if either ADCS or ADCI is HIGH.
2	AADR.2	Analog input select: these three bits are used to select one of the eight analog inputs of Port 5, for conversion. A selection can only be made when ADCI and ADCS are both LOW. AADR2 is the most significant bit (e.g. 100 selects the ADC4 analog input channel).
1	AADR.1	
0	AADR.0	

Table 11 Function of ADCI and ADCS bits

ADCI	ADCS	OPERATION
0	0	ADC not busy, a conversion can be started.
0	1	ADC busy, start of a new conversion is blocked.
1	0	Conversion completed; start of a new conversion is blocked.
1	1	Intermediate status for a maximum of one machine cycle before conversion is completed.

8-bit microcontroller

P83C562; P80C562

12 TIMER/ COUNTERS

The P8xC562 contains:

- Three 16-bit timer/event counters: Timer 0, Timer 1 and Timer 2
- One 8-bit Watchdog Timer.

12.1 Timer 0 and Timer 1

Timer 0 and Timer 1 may be programmed to carry out the following operations:

- Measure time intervals and pulse durations
- Count events
- Generate interrupt requests.

Timer 0 and Timer 1 can also be programmed independently to operate in three modes:

Mode 0 8-bit timer or 8-bit counter each with divide-by-32 prescaler

Mode 1 16-bit time-interval or event counter

Mode 2 8-bit time-interval or event counter with automatic reload upon overflow.

Timer 0 can be programmed to operate in an additional mode as follows:

Mode 3 one 8-bit time-interval or event counter and one 8-bit time-interval counter.

When Timer 0 is in Mode 3, Timer 1 can be programmed to operate in Modes 0, 1 or 2 but cannot set an interrupt request flag or generate an interrupt. However, the overflow from Timer 1 can be used to pulse the serial port transmission-rate generator.

The frequency handling range of these counters with a 16 MHz crystal is as follows:

- In the timer function, the timer is incremented at a frequency of 1.33 MHz; a division by 12 of the oscillator frequency
- 0 Hz to an upper limit of 0.66 MHz when programmed for external inputs.

Both internal and external inputs can be gated to the counter by a second external source for directly measuring pulse durations.

The counters are started and stopped under software control. Each one sets its interrupt request flag when it overflows from all logic 1s to all logic 0s (or automatic reload value), with the exception of Mode 3 as previously described.

12.2 Timer T2 Capture and Compare Logic

Timer T2 is a 16-bit timer/counter which has, coupled to it, capture and compare facilities. The operational diagram is shown in Fig.10.

The 16-bit timer/counter is clocked via a prescaler with a programmable division factor of 1, 2, 4 or 8. The input of the prescaler is clocked with $\frac{1}{12}$ of the oscillator frequency, or with positive edges on the T2 input, or it is switched to the off position. The prescaler is cleared if its division factor or its input source is changed, or if the timer/counter is reset. T2 is readable on-the-fly, but possesses no extra read latches; this means that software precautions have to be taken against misinterpretation on overflow from least to most significant byte during a read. T2 is not loadable and is reset by the RST signal or at the positive edge of the input signal RT2, if enabled. In the Idle mode the timer/counter and prescaler are reset and halted.

T2 is connected to four 16-bit Capture Registers: CT0, CT1, CT2 and CT3. These registers are loaded with the contents of T2 and an interrupt is requested upon receipt of the input signals CT0I, CT1I, CT2I or CT3I. These input signals are shared with Port 1. Using the Capture Register (CTCON), these inputs may invoke capture and interrupt request on a positive or negative edge or on both edges. If neither a positive nor a negative edge is selected for a capture input, no capture or interrupt request can be generated by this input.

The contents of the Compare Registers CM0, CM1 and CM2 are continually compared with the counter value of Timer 2. When a match is found an interrupt may be invoked. Using the match signal of CM0, the controller sets bits 0 to 5 of Port 4, if the corresponding bits of the Set Enable Register are logic 1s.

Considering a match with CM1, if the corresponding bits of the Reset/toggle Enable Register (RTE) are logic 1, then the controller will use the match signal to reset bits 0 to 5 of Port 4. Bits 6 and 7 of Port 4 may be toggled by the signal that indicates a match of Timer T2 and CM2 if the corresponding bits of RTE are logic 1. CM0, CM1 and CM2 are reset by the RST signal.

Port 4 can be read and written by software without affecting the toggle, set and reset signals. At byte overflow of the least significant byte, or at a 16-bit overflow of the timer/counter, an interrupt sharing the same interrupt vector is requested. Either one or both of these overflows can be programmed to request an interrupt.

All interrupt flags must be reset by software.

8-bit microcontroller

P83C562; P80C562

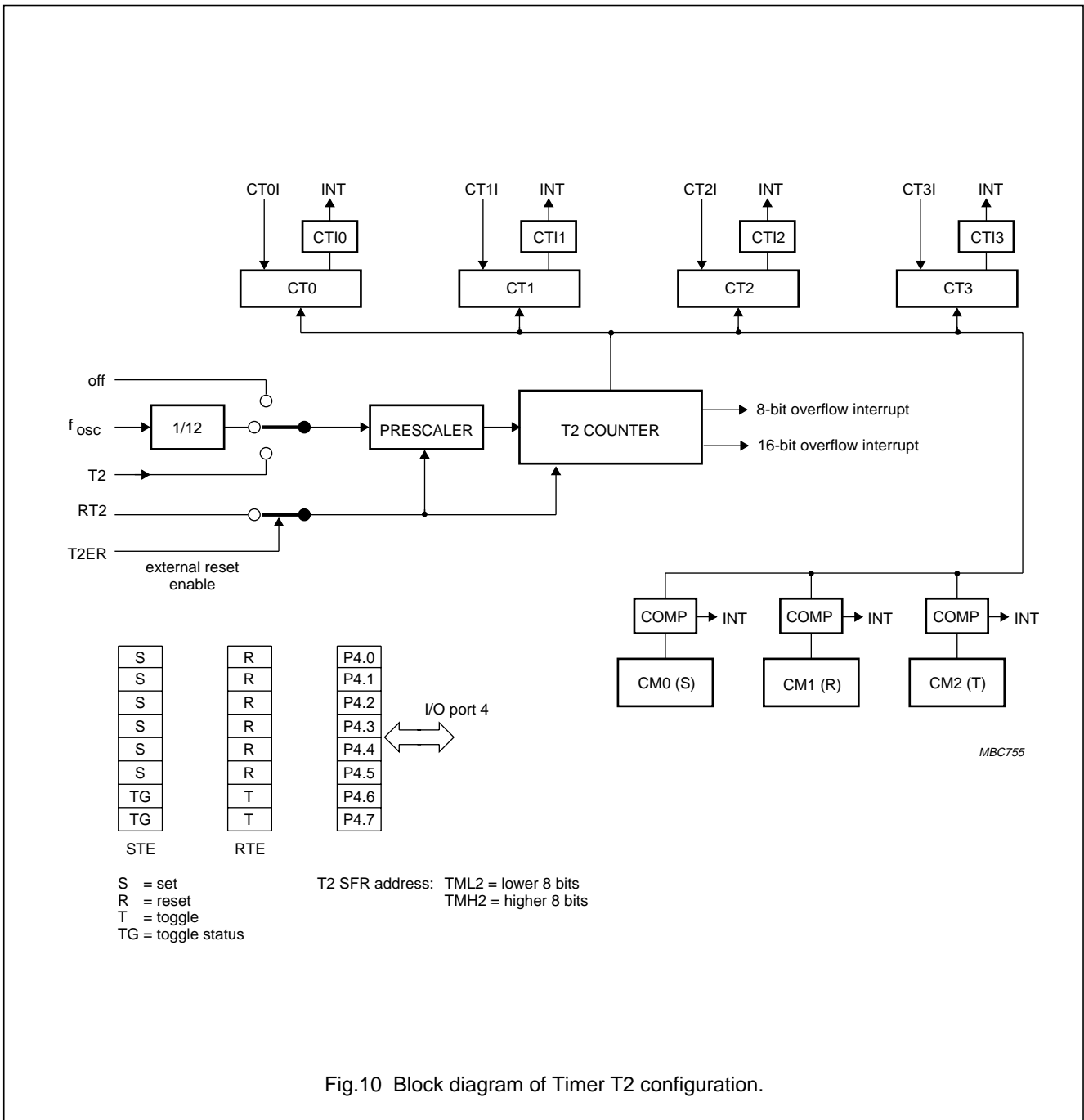

Fig.10 Block diagram of Timer T2 configuration.

8-bit microcontroller

P83C562; P80C562

12.2.1 T2 CONTROL REGISTER (TM2CON)

Table 12 T2 Control Register (SFR address EAH)

7	6	5	4	3	2	1	0
T2IS1	T2IS0	T2ER	T2B0	T2P1	T2P0	T2MS1	T2MS0

Table 13 Description of TM2CON bits

BIT	SYMBOL	DESCRIPTION
7	T2IS1	Timer 2 16-bit overflow interrupt select.
6	T2IS0	Timer 2 byte overflow interrupt select.
5	T2ER	Timer 2 external reset enable.
4	T2B0	Timer 2 byte overflow interrupt flag.
3	T2P1	Timer 2 prescaler select (see Table 14).
2	T2P0	
1	T2MS1	Timer 2 mode select (see Table 15).
0	T2MS0	

Table 14 Timer 2 prescaler select

T2P1	T2P0	T2 CLOCK
0	0	Clock source
0	1	$\frac{1}{2}$ clock source
1	0	$\frac{1}{4}$ clock source
1	1	$\frac{1}{8}$ clock source

Table 15 Timer 2 mode select

T2MS1	T2MS0	MODE
0	0	Timer T2 is halted
0	1	T2 clock source = $\frac{1}{12} \times f_{osc}$
1	0	Test mode; do not use
1	1	T2 clock source = pin T2

8-bit microcontroller

P83C562; P80C562

12.2.2 CAPTURE CONTROL REGISTER (CTCON)

Table 16 Capture Control Register (SFR address EBH)

7	6	5	4	3	2	1	0
CTN3	CTP3	CTN2	CTP2	CTN1	CTP1	CTN0	CTP0

Table 17 Description of CTCON bits

BIT	SYMBOL	DESCRIPTION
7	CTN3	Interrupt triggered on negative edge of CT3I.
6	CTP3	Interrupt triggered on positive edge of CT3I.
5	CTN2	Interrupt triggered on negative edge of CT2I.
4	CTP2	Interrupt triggered on positive edge of CT2I.
3	CTN1	Interrupt triggered on negative edge of CT1I.
2	CTP1	Interrupt triggered on positive edge of CT1I.
1	CTN0	Interrupt triggered on negative edge of CT0I.
0	CTP0	Interrupt triggered on positive edge of CT0I.

12.2.3 INTERRUPT FLAG REGISTER (TM2IR)

Table 18 Interrupt Flag Register (SFR address C8H)

7	6	5	4	3	2	1	0
T2OV	CMI2	CMI1	CMI0	CTI3	CTI2	CTI1	CTI0

Table 19 Description of TM2IR bits (see notes 1 and 2)

BIT	SYMBOL	DESCRIPTION
7	T2OV	T2: 16-bit overflow interrupt flag.
6	CMI2	CM2: interrupt flag.
5	CMI1	CM1: interrupt flag.
4	CMI0	CM0: interrupt flag.
3	CTI3	CT3: interrupt flag.
2	CTI2	CT2: interrupt flag.
1	CTI1	CT1: interrupt flag.
0	CTI0	CT0: interrupt flag.

Notes

1. Interrupt Enable Register 1 (IEN1) is used to enable/disable Timer 2 interrupts.
2. Interrupt Priority Register 1 (IP1) is used to determine the Timer 2 interrupt priority.

8-bit microcontroller

P83C562; P80C562

12.2.4 SET ENABLE REGISTER (STE)

Table 20 Set Enable Register (SFR address EEH)

7	6	5	4	3	2	1	0
TG47	TG46	SP45	SP44	SP43	SP42	SP41	SP40

Table 21 Description of STE bits (see notes 1 and 2)

BIT	SYMBOL	DESCRIPTION
7	TG47	If HIGH then P4.7 is reset on the next toggle, if LOW P4.7 is set on the next toggle.
6	TG46	If HIGH then P4.6 is reset on the next toggle, if LOW P4.6 is set on the next toggle.
5	SP45	If HIGH the P4.5 is set on a match of CM0 and T2.
4	SP44	If HIGH the P4.4 is set on a match of CM0 and T2.
3	SP43	If HIGH the P4.3 is set on a match of CM0 and T2.
2	SP42	If HIGH the P4.2 is set on a match of CM0 and T2.
1	SP41	If HIGH the P4.1 is set on a match of CM0 and T2.
0	SP40	If HIGH the P4.0 is set on a match of CM0 and T2.

Notes

1. If STE.n is LOW then P4.n is not affected by a match of CM0 and T2 (n = 0 to 5).
2. STE.6 and STE.7 are read only.

12.2.5 RESET/TOGGLE ENABLE REGISTER (RTE)

Table 22 Reset/toggle enable register (SFR address EFH)

7	6	5	4	3	2	1	0
TP47	TP46	RP45	RP44	RP43	RP42	RP41	RP40

Table 23 Description of RTE bits (note 1)

BIT	SYMBOL	DESCRIPTION
7	TP47	If HIGH then P4.7 toggles on a match of CM2 and T2.
6	TP46	If HIGH then P4.6 toggles on a match of CM2 and T2.
5	RP45	If HIGH then P4.5 is reset on a match of CM1 and T2.
4	RP44	If HIGH then P4.4 is reset on a match of CM1 and T2.
3	RP43	If HIGH then P4.3 is reset on a match of CM1 and T2.
2	RP42	If HIGH then P4.2 is reset on a match of CM1 and T2.
1	RP41	If HIGH then P4.1 is reset on a match of CM1 and T2.
0	RP40	If HIGH then P4.0 is reset on a match of CM1 and T2.

Note

1. If RTE.n is LOW then P4.n is not affected by a match of CM1 and T2 or CM2 and T2. For more information, refer to the 8051-based "8-bit Microcontrollers Data Handbook IC20".

8-bit microcontroller

P83C562; P80C562

12.3 Watchdog Timer (T3)

In addition to Timer T2 and the standard timers, a Watchdog Timer is also available, consisting of an 11-bit prescaler and a 8-bit timer. The functional diagram of the Watchdog Timer is shown in Fig.11. The timer is incremented every t seconds,

$$\text{where: } t = \frac{12 \times 2048}{f_{\text{OSC}}}$$

When a timer overflow occurs, the microcontroller is reset and a reset output pulse is generated at the RST pin.

To prevent a system reset the timer must be reloaded in time by the application software. If the processor suffers a hardware/ software malfunction, the software will fail to reload the timer. This failure will produce a reset upon overflow thus preventing the processor running out of control.

The Watchdog Timer can only be reloaded if the condition flag WLE in the Power Control Register has been previously set by software. At the moment the counter is loaded the condition flag is automatically cleared.

The timer interval between the timer's reloading and occurrence of a reset, is dependent upon the reloaded value. For example, this may range from 2 ms to 0.5 s when using an oscillator frequency of 12 MHz. In the Idle state the Watchdog Timer and reset circuitry remain active.

The Watchdog Timer is controlled by the Enable Watchdog pin ($\bar{E}W$). A logic 0 enables the Watchdog Timer and disables the Power-down mode. A logic 1 disables the Watchdog Timer and enables the Power-down mode.

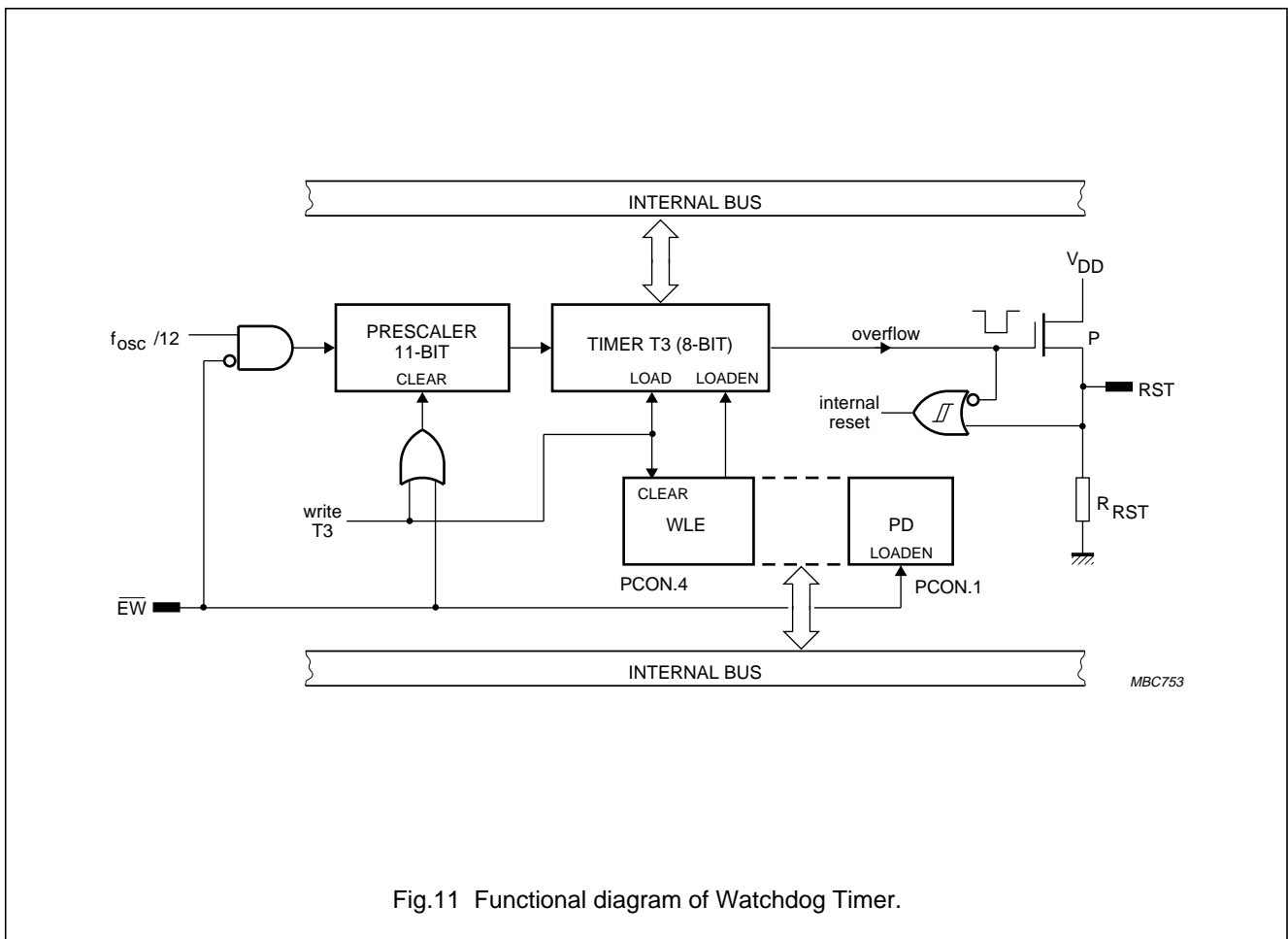

Fig.11 Functional diagram of Watchdog Timer.

8-bit microcontroller

P83C562; P80C562

13 SERIAL I/O

The P8x562 is equipped with a full duplex UART port and is identical to the serial port of the 80C51 (see 'Single-chip 8-bit Microcontrollers User Manual' .

14 INTERRUPT SYSTEM

External events and the real-time driven on-chip peripherals require service by the CPU asynchronously to the execution of any particular section of code. To tie the asynchronous activities of these functions to normal program execution a multiple-source, two-priority-level, nested interrupt system is provided. The interrupt system is shown in Fig.12. Interrupt response latency is from 2.25 μ s to 6 μ s when using a 16 MHz crystal.

The P8x562 acknowledges interrupt requests from 14 sources as follows:

- $\overline{\text{INT0}}$ and $\overline{\text{INT1}}$: externally via pins P3.2/ $\overline{\text{INT0}}$ and P3.3/ $\overline{\text{INT1}}$ respectively
- Timer 0 and Timer 1: from the two internal counters
- Timer T2 (8 separate interrupts): 4 capture interrupts, 3 compare interrupts and an overflow interrupt. If the Capture Register remains unused and its contents are 'don't care', then the corresponding input pin CTnI may be used as a positive and/or negative edge triggered external interrupt.
- ADC conversion completed interrupt
- UART serial I/O port interrupt.

Each interrupt vectors to a separate location in program memory for its service routine. Each source can be individually enabled or disabled by a corresponding bit in the IEN0 or IEN1 registers, in addition each interrupt may be programmed to a high or low priority level using the corresponding bit in the IP0 or IP1 registers. All enabled sources can be globally disabled or enabled. Both external interrupts can be programmed to be level-activated or transition-activated; an active LOW level allows 'wire-ORing' of several interrupt sources to the input pin.

14.1 Interrupt Vectors

Table 24 gives the vector address in Program Memory where the appropriate interrupt service routine is located.

Table 24 Interrupt vectors

SOURCE	SYMBOL	VECTOR
External 0	X0	0003H
Timer 0 overflow	T0	000BH
External 1	X1	0013H
Timer 1 overflow	T1	001BH
Serial I/O 0 (UART)	S0	0023H
T2 capture 0	CT0	0033H
T2 capture 1	CT1	003BH
T2 capture 2	CT2	0043H
T2 capture 3	CT3	004BH
ADC completion	ADC	0053H
T2 compare 0	CM0	005BH
T2 compare 1	CM1	0063H
T2 compare 2	CM2	006BH
T2 overflow	T2	0073H

14.2 Interrupt priority

Each interrupt source can be either high priority or low priority. If both priorities are requested simultaneously, the processor will branch to the high priority vector. If there are simultaneous requests from sources of the same priority, then interrupts will be serviced in the following order:

X0, ADC, T0, CT0, CM0, X1, CT1, CM1, T1, CT2, CM2, S0, CT3, T2.

A low priority interrupt routine can only be interrupted by a high priority interrupt. A high priority interrupt routine can not be interrupted.

8-bit microcontroller

P83C562; P80C562

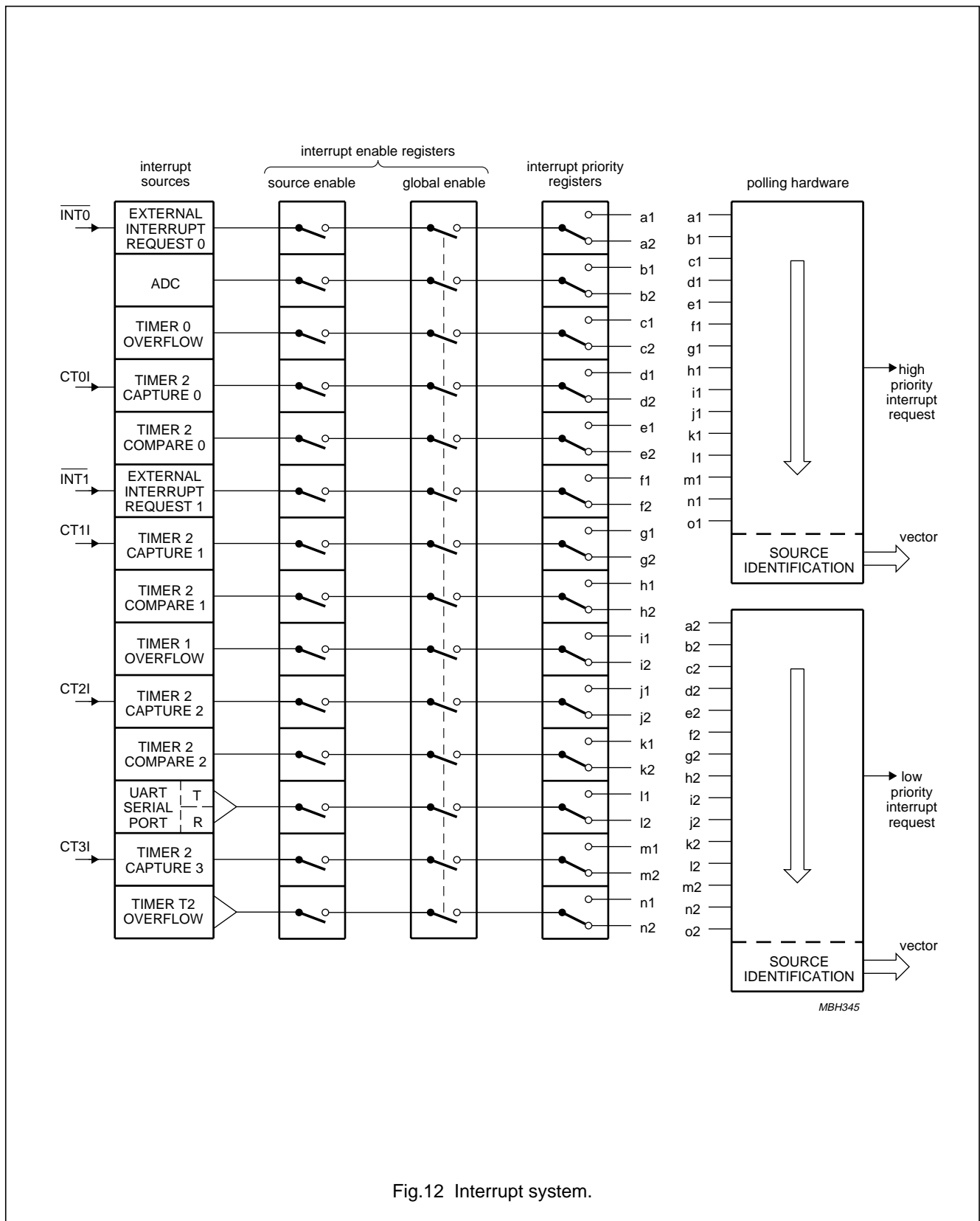

Fig.12 Interrupt system.

8-bit microcontroller

P83C562; P80C562

14.3 Interrupt Enable and Priority Registers

14.3.1 INTERRUPT ENABLE REGISTER 0 (IEN0)

Table 25 Interrupt Enable Register 0 (SFR address A8H)

7	6	5	4	3	2	1	0
EA	EAD	–	ES0	ET1	EX1	ET0	EX0

Table 26 Description of IEN0 bits (note 1)

BIT	SYMBOL	DESCRIPTION
7	EA	General enable/disable control. If EA = 0, then no interrupt is enabled. If EA =1, then any individually enabled interrupt will be accepted.
6	EAD	Enable ADC interrupt.
5	–	Reserved.
4	ES0	Enable SIO (UART) interrupt.
3	ET1	Enable Timer 1 interrupt.
2	EX1	Enable External interrupt.
1	ET0	Enable Timer 0 interrupt.
0	EX0	Enable External 0 interrupt.

Note

- Logic 0 = interrupt disabled; Logic 1 = interrupt enabled.

14.3.2 INTERRUPT ENABLE REGISTER 1 (IEN1)

Table 27 Interrupt Enable Register 1 (SFR address E8H)

7	6	5	4	3	2	1	0
ET2	ECM2	ECM1	ECM0	ECT3	ECT2	ECT1	ECT0

Table 28 Description of IEN1 bits (note 1)

BIT	SYMBOL	DESCRIPTION
7	ET2	Enable T2 overflow interrupt(s).
6	ECM2	Enable T2 comparator 2 interrupt.
5	ECM1	Enable T2 comparator 1 interrupt.
4	ECM0	Enable T2 comparator 0 interrupt.
3	ECT3	Enable T2 capture register 3 interrupt.
2	ECT1	Enable T2 capture register 2 interrupt.
1	ECT1	Enable T2 capture register 1 interrupt.
0	ECT0	Enable T2 capture register 0 interrupt.

Note

- Logic 0 = interrupt disabled; Logic 1 = interrupt enabled.

8-bit microcontroller

P83C562; P80C562

14.3.3 INTERRUPT PRIORITY REGISTER 0 (IP0)

Table 29 Interrupt Priority Register 0 (SFR address B8H)

7	6	5	4	3	2	1	0
–	PAD	–	PS0	PT1	PX1	PT0	PX0

Table 30 Description of IP0 bits (note 1)

BIT	SYMBOL	DESCRIPTION
7	–	Reserved.
6	PAD	ADC interrupt priority level.
5	–	Reserved.
4	PS0	SIO0 (UART) interrupt priority level.
3	PT1	Timer 1 interrupt priority level.
2	PX1	External interrupt 1 priority level.
1	PT0	Timer 0 interrupt priority level.
0	PX0	External interrupt 0 priority level.

Note

1. A logic 0 = low priority; a logic 1 = high priority.

14.3.4 INTERRUPT PRIORITY REGISTER 1 (IP1)

Table 31 Interrupt Priority Register 1 (SFR address F8H)

7	6	5	4	3	2	1	0
PT2	PCM2	PCM1	PCM0	PCT3	PCT2	PCT1	PCT0

Table 32 Description of IP1 bits (note 1)

BIT	SYMBOL	DESCRIPTION
7	PT2	T2 overflow interrupt(s) priority level.
6	PCM2	T2 comparator 2 interrupt priority interrupt level.
5	PCM1	T2 comparator 1 interrupt priority interrupt level.
4	PCM0	T2 comparator 0 interrupt priority interrupt level.
3	PCT3	T2 capture register 3 priority interrupt level.
2	PCT2	T2 capture register 2 priority interrupt level.
1	PCT1	T2 capture register 1 priority interrupt level.
0	PCT0	T2 capture register 0 priority interrupt level.

Note

1. A logic 0 = low priority; a logic 1 = high priority.

8-bit microcontroller

P83C562; P80C562

15 REDUCED POWER MODES**15.1 Idle and Power-down operation**

Idle mode operation permits the interrupt, serial ports and timer blocks to continue to function while the CPU is halted. The Idle and Power-down clock configuration is shown in Fig.13. The following functions are switched off when the processor enters the Idle mode.

- Timer T2 - stopped and reset
- PWM0 and PWM1 - reset, output HIGH
- ADC - aborted if in progress.

The following functions remain active during Idle mode. These functions may generate an interrupt or reset and thus end the Idle mode.

- Timer 0, Timer 1
- Timer T3
- SIO
- External Interrupt.

The Power-down operation freezes the oscillator. The Power-down mode can only be activated by setting the PD bit in the PCON register. The PD bit can only be set if the \overline{EW} input is HIGH.

15.1.1 IDLE MODE

The instruction that sets PCON.0 is the last instruction executed in the normal operating mode before Idle mode is activated. Once in the Idle mode, the CPU status is preserved in its entirety: the Stack Pointer, Program Counter, Program Status Word, Accumulator, RAM and all other registers maintain their data during Idle mode. The status of the external pins during Idle mode is shown in Table 33.

There are two ways to terminate the Idle mode:

- Activation of any enabled interrupt will cause PCON.0 to be cleared by hardware terminating the Idle mode.

The interrupt is serviced, and following the return from interrupt instruction RETI, the next instruction to be executed will be the one which follows the instruction that wrote a logic 1 to PCON.0. The flag bits GF0 and GF1 may be used to determine whether the interrupt was received during normal execution or during the Idle mode. For example, the instruction that writes to PCON.0 can also set or clear one or both flag bits. When Idle mode is terminated by an interrupt, the service routine can examine the status of the flag bits.

- The second way of terminating the Idle mode is with an external hardware reset, or an internal reset caused by an overflow of the Watchdog Timer (T3). Since the oscillator is still running, the hardware reset is required to be active for two machine cycles (24 oscillator periods but at least 2 μ s) to complete the reset operation.

15.1.2 POWER-DOWN MODE

The instruction that sets PCON.1 is the last executed prior to going into the Power-down mode. Once in Power-down mode, the oscillator is stopped. Only the contents of the on-chip RAM are preserved. The Special Function Registers are not saved. A hardware reset is the only way of exiting the Power-down mode.

In the Power-down mode, V_{DD} may be reduced to minimize circuit power consumption. The supply voltage must not be reduced until the Power-down mode is entered, and must be restored before the hardware reset is applied which will free the oscillator. Reset should not be released until the oscillator has restarted and stabilized.

The status of the external pins during Power-down mode is shown in Table 33. If the Power-down mode is activated while in external program memory, the port data that is held in the Special Function Register P2 is restored to Port 2. If the data is a logic 1, the port pin is held HIGH during the Power-down mode by the strong pull-up transistor p1 (see Fig.7).

Table 33 Status of external pins during Idle and Power-down modes

MODE	MEMORY	ALE	\overline{PSEN}	PORT 0	PORT 1	PORT 2	PORT 3	PORT 4	$\overline{PWM0}$
Idle	internal	1	1	port data	port data	port data	port data	port data	1
	external	1	1	floating	port data	port data	port data	port data	1
Power-down	internal	0	0	port data	port data	port data	port data	port data	1
	external	0	0	floating	port data	port data	port data	port data	1

8-bit microcontroller

P83C562; P80C562

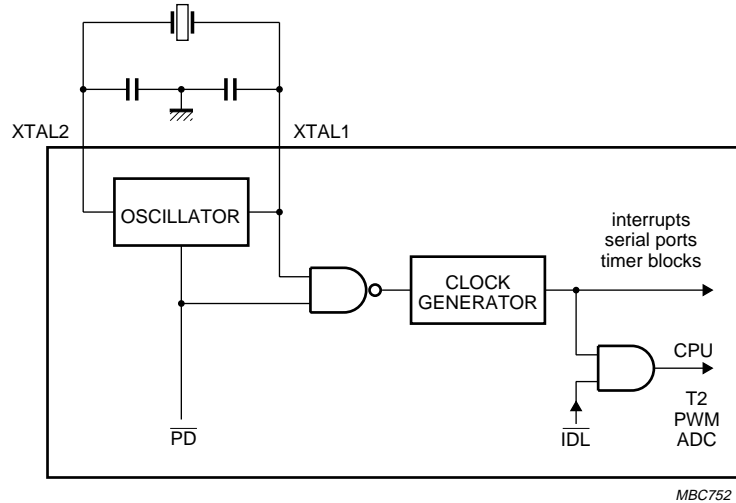

Fig.13 Internal Idle and Power-down clock configuration.

15.2 Power Control Register (PCON)

The reduced power modes are activated by software using this register. PCON is not bit addressable.

Table 34 Power Control Register (SFR address 87H)

7	6	5	4	3	2	1	0
SMOD	–	RFI	WLE	GF1	GF0	PD	IDL

Table 35 Description of PCON bits (note 1)

BIT	SYMBOL	DESCRIPTION
7	SMOD	Double Baud rate. When set to logic 1 the baud rate is doubled when the serial port SIO0 is being used in modes 1, 2 or 3.
6	–	Reserved.
5	RFI	Reduced radio frequency interference. When set to logic 1, the toggling of the ALE pin is prohibited; this bit is cleared on RESET (see Table 1).
4	WLE	Watchdog Load Enable. This flag must be set by software prior to loading the Watchdog Timer. It is cleared when the timer is loaded.
3	GF1	General-purpose flag bits.
2	GF0	
1	PD	Power-down bit. Setting this bit activates the Power-down mode. It can only be set if input \overline{EW} is HIGH.
0	IDL	Idle mode. Setting this bit activates the Idle mode.

Note

1. If logic 1s are written to PD and IDL at the same time, PD takes precedence. The reset value of PCON is (0X000000).

8-bit microcontroller

P83C562; P80C562

16 OSCILLATOR CIRCUITRY

The oscillator circuitry of the P8x562 is a single-stage inverting amplifier in a Pierce oscillator configuration. The circuitry between XTAL1 and XTAL2 is basically an inverter biased to the transfer point. Either a crystal or ceramic resonator can be used as the feedback element to complete the oscillator circuitry. Both are operated in parallel resonance. XTAL1 (pin 35) is the high gain amplifier input, and XTAL2 (pin 34) is the output (see Fig.14). To drive the P8x562 externally, XTAL1 is driven from an external source and XTAL2 left open-circuit (see Fig.15).

17 RESET CIRCUITRY

The reset circuitry for the P8x562 is connected to the reset pin RST. A Schmitt trigger is used at the input for noise rejection. The output of the Schmitt trigger is sampled by the reset circuitry every machine cycle. The on-chip Reset circuit is shown in Fig.16.

A reset is accomplished by holding the RST pin HIGH for at least two machine cycles (24 oscillator periods but at least 2 μ s). The CPU responds by executing an internal reset. During reset both ALE and PSEN output a HIGH level. In order to perform a correct reset, this level must not be affected by external elements.

Also with the P8x562, the RST line can be pulled HIGH internally by a pull-up transistor activated by the Watchdog Timer (T3). The length of the output pulse from the Watchdog Timer is 3 machine cycles. A pulse of such short duration is necessary in order to recover from a processor or system fault as fast as possible.

It can be seen that the short reset pulse from T3 cannot discharge the Power-on reset capacitor (see Fig.17). Consequently, when the Watchdog Timer is also used to reset external devices this capacitor arrangement should not be connected to the RST pin, and an extra circuit should be used to perform the Power-on-reset operation. It should be remembered that a T3 overflow, if enabled, will force a reset condition to the P8x562 by an internal connection, whether the output RST is tied LOW or not.

The internal reset is executed during the second cycle in which RST is HIGH and is repeated every cycle until RST goes LOW. The internal RAM is not affected by reset. When V_{DD} is turned on, the RAM content is indeterminate. An internal reset leaves the internal registers as shown in Table 36.

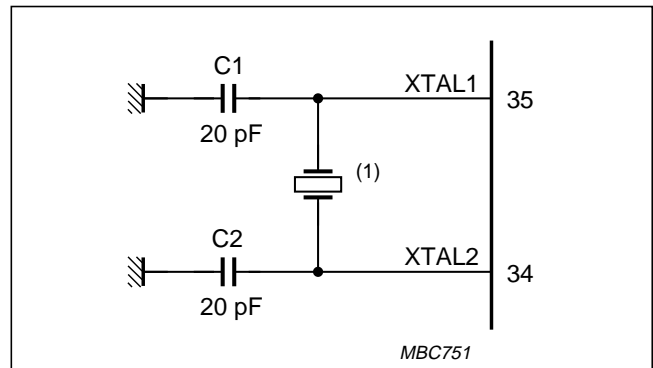

1) Use fundamental crystals only.

Fig.14 P8x562P8x562 oscillator circuit.

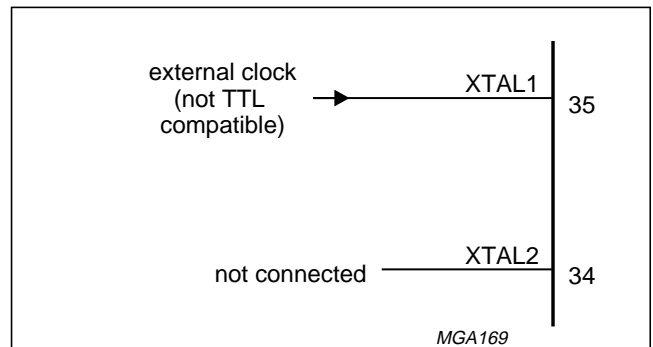

Fig.15 Driving the P8x562 from an external source.

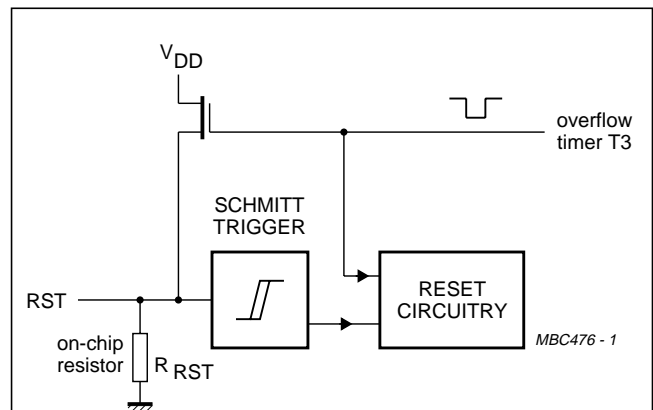

Fig.16 On-chip reset configuration.

8-bit microcontroller

P83C562; P80C562

Table 36 State of internal registers after an internal reset
X = undefined state.

REGISTER	7	6	5	4	3	2	1	0
ACC	0	0	0	0	0	0	0	0
ADCON	X	X	0	0	0	0	0	0
ADCH	X	X	X	X	X	X	X	X
B	0	0	0	0	0	0	0	0
CML0 to CML2	0	0	0	0	0	0	0	0
CMH0 to CMH2	0	0	0	0	0	0	0	0
CTCON	0	0	0	0	0	0	0	0
CTL0 to CTL3	X	X	X	X	X	X	X	X
CTH0 to CTH3	X	X	X	X	X	X	X	X
DPL	0	0	0	0	0	0	0	0
DPH	0	0	0	0	0	0	0	0
IEN0	0	0	0	0	0	0	0	0
IEN1	0	0	0	0	0	0	0	0
IP0	X	0	0	0	0	0	0	0
IP1	0	0	0	0	0	0	0	0
PCH	0	0	0	0	0	0	0	0
PCL	0	0	0	0	0	0	0	0
PCON	0	X	0	0	0	0	0	0
PSW	0	0	0	0	0	0	0	0
PWM0	0	0	0	0	0	0	0	0
PWM1	0	0	0	0	0	0	0	0
PWMP	0	0	0	0	0	0	0	0
P0 to P4	1	1	1	1	1	1	1	1
P5	X	X	X	X	X	X	X	X
RTE	0	0	0	0	0	0	0	0
SBUF	X	X	X	X	X	X	X	X
SCON	0	0	0	0	0	0	0	0
SP	0	0	0	0	0	1	1	1
STE	1	1	0	0	0	0	0	0
TCON	0	0	0	0	0	0	0	0
TH0, TH1	0	0	0	0	0	0	0	0
TMH2	0	0	0	0	0	0	0	0
TL0, TL1	0	0	0	0	0	0	0	0
TML2	0	0	0	0	0	0	0	0
TMOD	0	0	0	0	0	0	0	0
TM2CON	0	0	0	0	0	0	0	0
TM2IR	0	0	0	0	0	0	0	0
T3	0	0	0	0	0	0	0	0

17.1 Power-on-reset

When V_{DD} is turned on, and provided its rise-time does not exceed 10 ms, an automatic reset can be obtained by connecting the RST pin to V_{DD} via a 2.2 μ F capacitor. When the power is switched on, the voltage on the RST pin, is equal to V_{DD} minus the capacitor voltage, and decreases from V_{DD} as the capacitor charges through the internal resistor (R_{RST}) to ground. The larger the capacitor, the more slowly V_{RST} decreases. V_{RST} must remain above the lower threshold of the Schmitt trigger long enough to effect a complete reset. The time required is the oscillator start-up time, plus 2 machine cycles. The port pins will be in a random state until the oscillator has started and the internal reset algorithm has written logic 1s to the port pins. The Power-on-reset circuitry is shown in Fig.17.

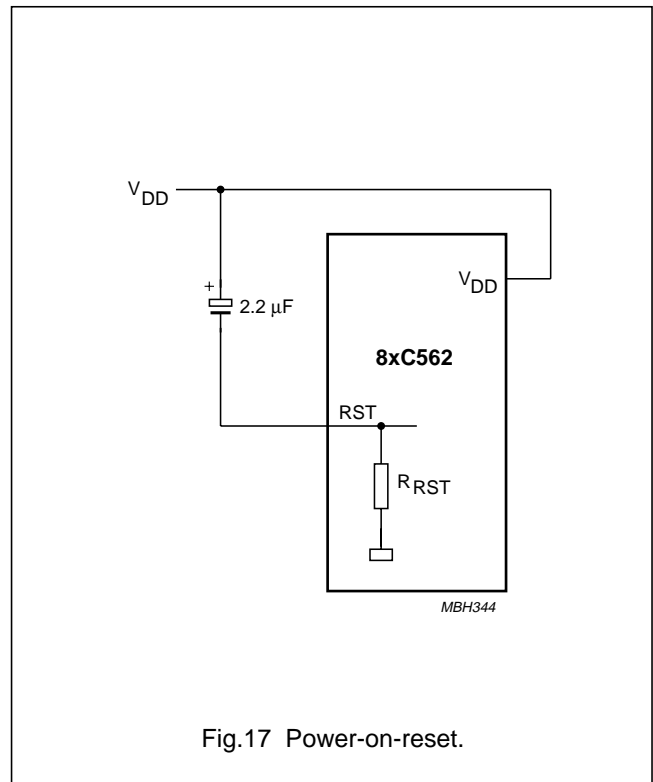

Fig.17 Power-on-reset.

8-bit microcontroller

P83C562; P80C562

18 INSTRUCTION SET

The P8x562 uses the powerful instruction set of the 80C51. Additional Special Function Registers are incorporated to control the on-chip peripherals. The instruction set consists of 49 single-byte, 45 two-byte and 17 three-byte instructions. When using a 16 MHz oscillator, 64 instructions execute in 0.75 μ s and 45 instructions execute in 1.5 μ s. Multiply and divide instructions execute in 3 μ s.

Tables 37 to 41 describe the Instruction set; Table 42 explains the Data addressing modes and the Hexadecimal opcodes.

Table 37 Instruction set descriptions: Arithmetic operations

MNEMONIC	DESCRIPTION	BYTES	CYCLES	OPCODE (HEX)
Arithmetic operations				
ADD A,Rr	Add register to A	1	1	2*
ADD A,direct	Add direct byte to A	2	1	25
ADD A,@Ri	Add indirect RAM to A	1	1	26, 27
ADD A,#data	Add immediate data to A	2	1	24
ADDC A,Rr	Add register to A with carry flag	1	1	3*
ADDC A,direct	Add direct byte to A with carry flag	2	1	35
ADDC A,@Ri	Add indirect RAM to A with carry flag	1	1	36, 37
ADDC A,#data	Add immediate data to A with carry flag	2	1	34
SUBB A,Rr	Subtract register from A with borrow	1	1	9*
SUBB A,direct	Subtract direct byte from A with borrow	2	1	95
SUBB A,@Ri	Subtract indirect RAM from A with borrow	1	1	96, 97
SUBB A,#data	Subtract immediate data from A with borrow	2	1	94
INC A	Increment A	1	1	04
INC Rr	Increment register	1	1	0*
INC direct	Increment direct byte	2	1	05
INC @Ri	Increment indirect RAM	1	1	06, 07
DEC A	Decrement A	1	1	14
DEC Rr	Decrement register	1	1	1*
DEC direct	Decrement direct byte	2	1	15
DEC @Ri	Decrement indirect RAM	1	1	16, 17
INC DPTR	Increment data pointer	1	2	A3
MUL AB	Multiply A & B	1	4	A4
DIV AB	Divide A by B	1	4	84
DA A	Decimal adjust A	1	1	D4

8-bit microcontroller

P83C562; P80C562

Table 38 Instruction set description: Logic operations

MNEMONIC	DESCRIPTION	BYTES	CYCLES	OPCODE (HEX)
Logic operations				
ANL A,Rr	AND register to A	1	1	5*
ANL A,direct	AND direct byte to A	2	1	55
ANL A,@Ri	AND indirect RAM to A	1	1	56, 57
ANL A,#data	AND immediate data to A	2	1	54
ANL direct,A	AND A to direct byte	2	1	52
ANL direct,#data	AND immediate data to direct byte	3	2	53
ORL A,Rr	OR register to A	1	1	4*
ORL A,direct	OR direct byte to A	2	1	45
ORL A,@Ri	OR indirect RAM to A	1	1	46, 47
ORL A,#data	OR immediate data to A	2	1	44
ORL direct,A	OR A to direct byte	2	1	42
ORL direct,#data	OR immediate data to direct byte	3	2	43
XRL A,Rr	Exclusive-OR register to A	1	1	6*
XRL A,direct	Exclusive-OR direct byte to A	2	1	65
XRL A,@Ri	Exclusive-OR indirect RAM to A	1	1	66, 67
XRL A,#data	Exclusive-OR immediate data to A	2	1	64
XRL direct,A	Exclusive-OR A to direct byte	2	1	62
XRL direct,#data	Exclusive-OR immediate data to direct byte	3	2	63
CLR A	Clear A	1	1	E4
CPL A	Complement A	1	1	F4
RL A	Rotate A left	1	1	23
RLC A	Rotate A left through the carry flag	1	1	33
RR A	Rotate A right	1	1	03
RRC A	Rotate A right through the carry flag	1	1	13
SWAP A	Swap nibbles within A	1	1	C4

8-bit microcontroller

P83C562; P80C562

Table 39 Instruction set description: Data transfer

MNEMONIC	DESCRIPTION	BYTES	CYCLES	OPCODE (HEX)
Data transfer				
MOV A,Rr	Move register to A	1	1	E*
MOV A,direct	Move direct byte to A	2	1	E5
MOV A,@Ri	Move indirect RAM to A	1	1	E6, E7
MOV A,#data	Move immediate data to A	2	1	74
MOV Rr,A	Move A to register	1	1	F*
MOV Rr,direct	Move direct byte to register	2	2	A*
MOV Rr,#data	Move immediate data to register	2	1	7*
MOV direct,A	Move A to direct byte	2	1	F5
MOV direct,Rr	Move register to direct byte	2	2	8*
MOV direct,direct	Move direct byte to direct byte	3	2	85
MOV direct,@Ri	Move indirect RAM to direct byte	2	2	86, 87
MOV direct,#data	Move immediate data to direct byte	3	2	75
MOV @Ri,A	Move A to indirect RAM	1	1	F6, F7
MOV @Ri,direct	Move direct byte to indirect RAM	2	2	A6, A7
MOV @Ri,#data	Move immediate data to indirect RAM	2	1	76, 77
MOV DPTR,#data16	Load data pointer with a 16-bit constant	3	2	90
MOVC A,@A+DPTR	Move code byte relative to DPTR to A	1	2	93
MOVC A,@A+PC	Move code byte relative to PC to A	1	2	83
MOVX A,@Ri	Move external RAM (8-bit address) to A	1	2	E2, E3
MOVX A,@DPTR	Move external RAM (16-bit address) to A	1	2	E0
MOVX @Ri,A	Move A to external RAM (8-bit address)	1	2	F2, F3
MOVX @DPTR,A	Move A to external RAM (16-bit address)	1	2	F0
PUSH direct	Push direct byte onto stack	2	2	C0
POP direct	Pop direct byte from stack	2	2	D0
XCH A,Rr	Exchange register with A	1	1	C*
XCH A,direct	Exchange direct byte with A	2	1	C5
XCH A,@Ri	Exchange indirect RAM with A	1	1	C6, C7
XCHD A,@Ri	Exchange LOW-order nibble indirect RAM with A	1	1	D6, D7

8-bit microcontroller

P83C562; P80C562

Table 40 Instruction set description: Program and machine control

MNEMONIC	DESCRIPTION	BYTES	CYCLES	OPCODE (HEX)
Program and machine control				
ACALL addr11	Absolute subroutine call	2	2	•1
LCALL addr16	Long subroutine call	3	2	12
RET	Return from subroutine	1	2	22
RETI	Return from interrupt	1	2	32
AJMP addr11	Absolute jump	2	2	♦1
LJMP addr16	Long jump	3	2	02
SJMP rel	Short jump (relative address)	2	2	80
JMP @A+DPTR	Jump indirect relative to the DPTR	1	2	73
JZ rel	Jump if A is zero	2	2	60
JNZ rel	Jump if A is not zero	2	2	70
JC rel	Jump if carry flag is set	2	2	40
JNC rel	Jump if carry flag is not set	2	2	50
JB bit,rel	Jump if direct bit is set	3	2	20
JNB bit,rel	Jump if direct bit is not set	3	2	30
JBC bit,rel	Jump if direct bit is set and clear bit	3	2	10
CJNE A,direct,rel	Compare direct to A and jump if not equal	3	2	B5
CJNE A,#data,rel	Compare immediate to A and jump if not equal	3	2	B4
CJNE Rr,#data,rel	Compare immediate to reg. and jump if not equal	3	2	B*
CJNE @Ri,#data,rel	Compare immediate to ind. and jump if not equal	3	2	B6, B7
DJNZ Rr,rel	Decrement register and jump if not zero	2	2	D*
DJNZ direct,rel	Decrement direct and jump if not zero	3	2	D5
NOP	No operation	1	1	00

8-bit microcontroller

P83C562; P80C562

Table 41 Instruction set description: Boolean variable manipulation

MNEMONIC		DESCRIPTION	BYTES	CYCLES	OPCODE (HEX)
Boolean variable manipulation					
CLR	C	Clear carry flag	1	1	C3
CLR	bit	Clear direct bit	2	1	C2
SETB	C	Set carry flag	1	1	D3
SETB	bit	Set direct bit	2	1	D2
CPL	C	Complement carry flag	1	1	B3
CPL	bit	Complement direct bit	2	1	B2
ANL	C,bit	AND direct bit to carry flag	2	2	82
ANL	C,/bit	AND complement of direct bit to carry flag	2	2	B0
ORL	C,bit	OR direct bit to carry flag	2	2	72
ORL	C,/bit	OR complement of direct bit to carry flag	2	2	A0
MOV	C,bit	Move direct bit to carry flag	2	1	A2
MOV	bit,C	Move carry flag to direct bit	2	2	92

Table 42 Description of the mnemonics in the instruction set

MNEMONIC	DESCRIPTION
Data addressing modes	
Rr	Working register R0-R7.
direct	128 internal RAM locations and any special function register (SFR).
@Ri	Indirect internal RAM location addressed by register R0 or R1 of the actual register bank.
#data	8-bit constant included in instruction.
#data 16	16-bit constant included as bytes 2 and 3 of instruction.
bit	direct addressed bit in internal RAM or SFR.
addr16	16-bit destination address. Used by LCALL and LJMP. The branch will be anywhere within the 64 kbytes program memory address space.
addr11	11-bit destination address. Used by ACALL and AJMP. The branch will be within the same 2 kbytes page of program memory as the first byte of the following instruction.
rel	Signed (two's complement) 8-bit offset byte. Used by SJMP and all conditional jumps. Range is -128 to +127 bytes relative to first byte of the following instruction.
Hexadecimal opcode cross-reference	
*	8, 9, A, B, C, D, E, F.
•	1, 3, 5, 7, 9, B, D, F.
♦	0, 2, 4, 6, 8, A, C, E.

8-bit microcontroller

P83C562; P80C562

Table 43 Instruction map

↓	First hexadecimal character of opcode			← Second hexadecimal character of opcode			→									
	0	1	2	3	4	5	6	7	8	9	A	B	C	D	E	F
0	NOP	AJMP addr11	LJMP addr16	RR A	INC A	INC direct	INC @Ri 0	1	0	1	2	3	4	5	6	7
1	JBC bit,rel	ACALL addr11	LCALL addr16	RRC A	DEC A	DEC direct	DEC @Ri 0	1	0	1	2	3	4	5	6	7
2	JB bit,rel	AJMP addr11	RET	RL A	ADD A,#data	ADD A,direct	ADD A,@Ri 0	1	0	1	2	3	4	5	6	7
3	JNB bit,rel	ACALL addr11	RETI	RLC A	ADDC A,#data	ADDC A,direct	ADDC A,@Ri 0	1	0	1	2	3	4	5	6	7
4	JC rel	AJMP addr11	ORL direct,A	ORL direct,#data	ORL A,#data	ORL A,direct	ORL A,@Ri 0	1	0	1	2	3	4	5	6	7
5	JNC rel	ACALL addr11	ANL direct,A	ANL direct,#data	ANL A,#data	ANL A,direct	ANL A,@Ri 0	1	0	1	2	3	4	5	6	7
6	JZ rel	AJMP addr11	XRL direct,A	XRL direct,#data	XRL A,#data	XRL A,direct	XRL A,@Ri 0	1	0	1	2	3	4	5	6	7
7	JNZ rel	ACALL addr11	ORL C,bit	JMP @A+DPTR	MOV A,#data	MOV direct,#data	MOV @Ri,#data 0	1	0	1	2	3	4	5	6	7
8	SJMP rel	AJMP addr11	ANL C,bit	MOVC A,@A+PC	DIV AB	MOV direct,direct	MOV direct,@Ri 0	1	0	1	2	3	4	5	6	7
9	MOV DTPR,#data16	ACALL addr11	MOV bit,C	MOVC A,@A+DPTR	SUBB A,#data	SUBB A,direct	SUBB A,@Ri 0	1	0	1	2	3	4	5	6	7
A	ORL C,/bit	AJMP addr11	MOV bit,C	INC DPTR	MUL AB		MOV @Ri,direct 0	1	0	1	2	3	4	5	6	7
B	ANL C,/bit	ACALL addr11	CPL bit	CPL C	CJNE A,#data,rel	CJNE A,direct,rel	CJNE @Ri,#data,rel 0	1	0	1	2	3	4	5	6	7
C	PUSH direct	AJMP addr11	CLR bit	CLR C	SWAP A	XCH A,direct	XCH A,@Ri 0	1	0	1	2	3	4	5	6	7
D	POP direct	ACALL addr11	SETB bit	SETB C	DA A	DJNZ direct,rel	XCHD A,@Ri 0	1	0	1	2	3	4	5	6	7
E	MOVX A,@DTPR	AJMP addr11	MOVX A,@Ri 0	MOVX A,@Ri 1	CLR A	MOV A,direct ⁽¹⁾	MOV A,@Ri 0	1	0	1	2	3	4	5	6	7
F	MOVX @DTPR,A	ACALL addr11	MOVX @Ri,A 0	MOVX @Ri,A 1	CPL A	MOV direct,A	MOV @Ri,A 0	1	0	1	2	3	4	5	6	7

Note

1. MOV A, ACC is not a valid instruction.

8-bit microcontroller

P83C562; P80C562

19 LIMITING VALUES

In accordance with the Absolute Maximum Rating System (IEC 134).

SYMBOL	PARAMETER	MIN.	MAX.	UNIT
V_I	input voltage on any pin with respect to ground (V_{SS})	-0.5	+6.5	V
I_I, I_O	input, output DC current on any single I/O pin	-	5.0	mA
P_{tot}	total power dissipation	-	1.0	W
T_{stg}	storage temperature range	-65	+150	°C
T_{amb}	operating ambient temperature range			
	P8xC562EBx	0	+70	°C
	P8xC562EFx	-40	+85	°C
	P8xC562EHx	-40	+125	°C

20 DC CHARACTERISTICS

$V_{DD} = 5\text{ V} \pm 10\%$; $V_{SS} = 0\text{ V}$; all voltages with respect to V_{SS} unless otherwise specified; $f_{OSC} = 16\text{ MHz}$.

$T_{amb} = -40\text{ to }+85\text{ °C}$ for the **P8xC562EFx**.

SYMBOL	PARAMETER	CONDITIONS	MIN.	MAX.	UNIT
Supply (digital part)					
V_{DD}	supply voltage P8xC562Exx		4.5	5.5	V
I_{DD}	operating supply current P8xC562Exx	note 1	-	40	mA
$I_{DD(ID)}$	supply current Idle mode P8xC562Exx	note 2	-	9	mA
$I_{DD(PD)}$	supply current Power-down mode	note 3			
	P8X562EBx	$2\text{ V} < V_{DD(PD)} < V_{DD(max)}$	-	50	μA
	P8X562EFx	$2\text{ V} < V_{DD(PD)} < V_{DD(max)}$	-	50	μA
	P8X562EHx	$2\text{ V} < V_{DD(PD)} < V_{DD(max)}$	-	150	μA
Inputs					
V_{IL}	LOW level input voltage (except \overline{EA})		-0.5	$0.2V_{DD} - 0.1$	V
V_{IL1}	LOW level input voltage (\overline{EA})		-0.5	$0.2V_{DD} - 0.3$	V
V_{IH}	HIGH level input voltage (except RST, XTAL1)		$0.2V_{DD} + 0.9$	$V_{DD} + 0.5$	V
V_{IH1}	HIGH level input voltage (RST and XTAL1)		$0.7V_{DD}$	$V_{DD} + 0.5$	V
I_{IL}	input current logic 0 Ports 1, 2, 3 and 4; (except P1.6/SCL, P1.7/SDA)	$V_I = 0.45\text{ V}$	-	-50	μA
I_{TL}	input current HIGH-to-LOW transition (Ports 1, 2, 3 and 4)	$V_I = 2.0\text{ V}$	-	-650	μA
I_{LI1}	input leakage current (Port 0, \overline{EA} , STADC, \overline{EW})	$0.45\text{ V} < V_I < V_{DD}$	-	± 10	μA
I_{LI3}	input leakage current (Port 5)	$0.45\text{ V} < V_I < V_{DD}$	-	± 1	μA

8-bit microcontroller

P83C562; P80C562

SYMBOL	PARAMETER	CONDITIONS	MIN.	MAX.	UNIT
Outputs					
V _{OL}	LOW level output voltage (Ports 1, 2, 3 and 4)	I _{OL} = 1.6 mA; note 4	–	0.45	V
V _{OL1}	LOW level output voltage (Port 0, ALE, PSEN, PWM0, PWM1)	I _{OL} = 3.2 mA; note 4	–	0.45	V
V _{OH}	HIGH level output voltage Ports 1, 2, 3 and 4	I _{OH} = –60 µA	2.4	–	V
		I _{OH} = –25 µA	0.75V _{DD}	–	V
		I _{OH} = –10 µA	0.9V _{DD}	–	V
V _{OH1}	HIGH level output voltage Port 0 in external bus mode, ALE, PSEN, PWM0, PWM1; note 5	I _{OH} = –800 µA	2.4	–	V
		I _{OH} = –300 µA	0.75V _{DD}	–	V
		I _{OH} = –80 µA	0.9V _{DD}	–	V
V _{OH2}	HIGH level output voltage (RST)	I _{OH} = –400 µA	2.4	–	V
		I _{OH} = –120 µA	0.8V _{DD}	–	V
R _{RST}	RST pull-down resistor		50	150	kΩ
C _{I/O}	capacitance of I/O buffer	test frequency = 1 MHz; T _{amb} = 25 °C	–	10	pF
Supply (analog part)					
V _{DDA}	supply voltage P8X562Exx	V _{DDA} = V _{DD} ±0.2 V	4.5	5.5	V
I _{DDA}	supply current operating	Port 5 = 0 to V _{DDA}		1.2	mA
I _{DDA(ID)}	supply current Idle mode P8X562EBx P8X562EFx P8X562EHx		–	50	µA
			–	50	µA
			–	100	µA
I _{DDA(PD)}	supply current Power-down mode P8X562EBx P8X562EFx P8X562EHx	2 V < V _{DDA(PD)} < V _{DDA(max)}	–	50	µA
			–	50	µA
			–	100	µA

8-bit microcontroller

P83C562; P80C562

SYMBOL	PARAMETER	CONDITIONS	MIN.	MAX.	UNIT
Analog inputs					
V_{IN}	analog input voltage		$AV_{SS} - 0.2$	$AV_{DD} + 0.2$	V
V_{REF+}	reference voltage (+)		–	$AV_{DD} + 0.2$	V
V_{REF-}	reference voltage (–)		$AV_{SS} - 0.2$	–	V
R_{REF}	resistance between V_{REF+} and V_{REF-}		5	25	k Ω
C_{IA}	analog input capacitance		–	15	pF
t_{ADS}	sampling time		–	$6t_{CY}$	μ s
t_{ADC}	conversion time (including sample time)		–	$24t_{CY}$	μ s
DL_e	differential non-linearity	notes 7 and 11	–	± 1	LSB
IL_e	integral non-linearity	notes 6 and 8	–	± 1	LSB
OS_e	offset error	notes 6 and 10	–	± 1	LSB
G_e	gain error	notes 6 and 9	–	± 0.4	%
M_{ctc}	channel-to-channel matching		–	± 1	LSB
C_t	crosstalk between P5 inputs	0 to 100 kHz	–	–60	dB

Notes to the DC characteristics

- The operating supply current is measured with all output pins disconnected; XTAL1 driven with $t_r = t_f = 10$ ns; $V_{IL} = V_{SS} + 0.5$ V; $V_{IH} = V_{DD} - 0.5$ V; XTAL2 not connected; $\overline{EA} = RST = Port\ 0 = \overline{EW} = V_{DD}$; $STADC = V_{SS}$.
- The Idle mode supply current is measured with all output pins disconnected; XTAL1 driven with $t_r = t_f = 10$ ns; $V_{IL} = V_{SS} + 0.5$ V; $V_{IH} = V_{DD} - 0.5$ V; XTAL2 not connected; $\overline{EA} = Port\ 0 = \overline{EW} = V_{DD}$; $RST = STADC = V_{SS}$.
- The Power-down current is measured with all output pins disconnected; XTAL2 not connected; $\overline{EA} = Port\ 0 = \overline{EW} = V_{DD}$; $RST = STADC = XTAL1 = V_{SS}$.
- Capacitive loading on Ports 0 and 2 may cause spurious noise pulses to be superimposed on the low level output voltage of ALE and Ports 1, 3 and 4. The noise is due to external bus capacitance discharging into the Port 0 and Port 2 pins when these pins make HIGH-to-LOW transitions during bus operations. In the most adverse condition (capacitive loading > 100 pF), the noise pulse on the ALE line may exceed 0.8 V. In such events it may be required to qualify ALE with a Schmitt trigger, or use an address latch with a Schmitt trigger strobe input.
- Capacitive loading on Ports 0 and 2 may cause the high level output voltage on ALE and \overline{PSEN} to momentarily fall below to $0.9V_{DD}$ specification when the address bits are stabilizing.
- $V_{REF+} = 5.12$ V; $V_{REF-} = 0$ V; $V_{DDA} = 5.0$ V.
- The differential non-linearity (DL_e) is the difference between the actual step width and the ideal step width.
- The integral non-linearity (IL_e) is the peak difference between the centre of the steps of the actual and the ideal transfer curve after appropriate adjustment of gain and offset error.
- The gain error (G_e) is the relative difference in percent between the straight line fitting the actual transfer curve after removing offset error, and the straight line which fits the ideal transfer curve. Gain error is constant at every point on the transfer curve.
- The offset error (OS_e) is the absolute difference between the straight line which fits the actual transfer curve after removing gain error, and a straight line which fits the ideal transfer curve. The offset error is constant at every point of the actual transfer curve.
- $V_{REF-} = 0$ V; $V_{DDA} = 5$ V; $V_{REF+} = 5.12$ V. The ADC is monotonic with no missing codes. Measurement by continuously increasing V_{IN} from –20 mV to 5.12 V in increments of 2 mV.

8-bit microcontroller

P83C562; P80C562

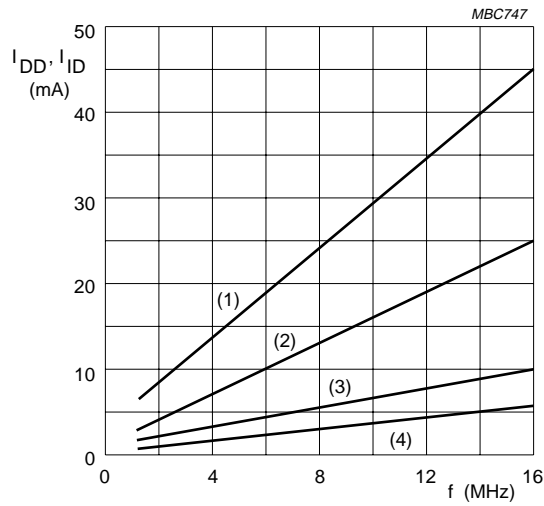

- (1) $I_{DD(max)}$ operating mode; $V_{DD} = 5.5$ V.
 - (2) $I_{DD(max)}$ operating mode; $V_{DD} = 4.5$ V.
 - (3) $I_{ID(max)}$ Idle mode; $V_{DD} = 5.5$ V.
 - (4) $I_{ID(max)}$ Idle mode; $V_{DD} = 4.5$ V.
- These values are valid within the specified frequency range.

Fig.18 Supply current (I_{DD} , I_{ID}) as a function of frequency at XTAL1 (f_{osc}).

8-bit microcontroller

P83C562; P80C562

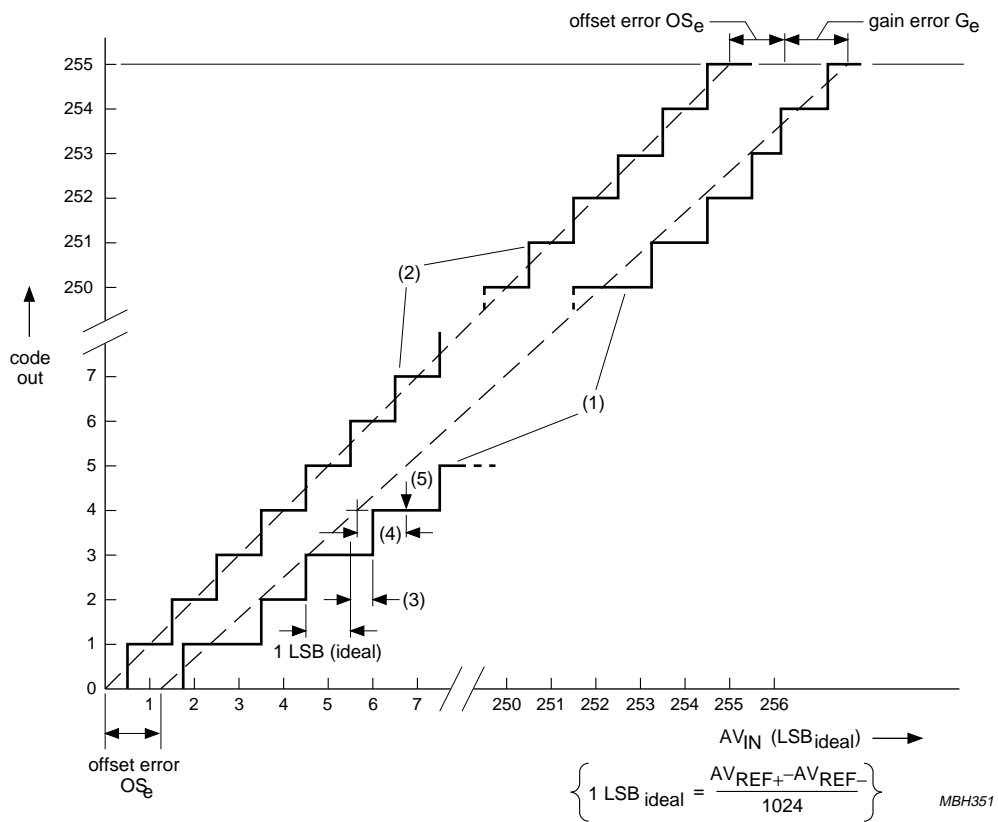

- (1) Example of an actual transfer curve.
- (2) The ideal transfer curve.
- (3) Differential non-linearity (DL_e).
- (4) Integral non-linearity (IL_e).
- (5) Centre of a step of the actual transfer curve.

Fig.19 ADC conversion characteristic.

8-bit microcontroller

P83C562; P80C562

21 AC CHARACTERISTICS

Parameters are valid over operating temperature range and operating supply voltage range unless otherwise specified. $C_L = 100$ pF for Port 0, ALE and \overline{PSEN} ; $C_L = 80$ pF for all other outputs unless specified. See Figs 23 to 25.

SYMBOL	PARAMETER	$f_{osc} = 16$ MHz		$f_{osc} = \text{VARIABLE}$		UNIT
		MIN.	MAX.	MIN.	MAX.	
Program memory						
t_{LL}	ALE pulse duration	85	–	$2t_{CLK} - 40$	–	ns
t_{AL}	address set-up time to ALE	8	–	$t_{CLK} - 55$	–	ns
t_{LA}	address hold time after ALE	28	–	$t_{CLK} - 35$	–	ns
t_{LIV}	time from ALE to valid instruction input	–	150	–	$4t_{CLK} - 100$	ns
t_{LC}	time from ALE to control pulse \overline{PSEN}	23	–	$t_{CLK} - 40$	–	ns
t_{CC}	control pulse duration \overline{PSEN}	143	–	$3t_{CLK} - 45$	–	ns
t_{CIV}	time from \overline{PSEN} to valid instruction input	–	83	–	$3t_{CLK} - 105$	ns
t_{CI}	input instruction hold time after \overline{PSEN}	0	–	0	–	ns
t_{CIF}	input instruction float delay after \overline{PSEN}	–	38	–	$t_{CLK} - 25$	ns
t_{AIV}	address to valid instruction input	–	208	–	$5t_{CLK} - 105$	ns
t_{AFC}	address float delay after \overline{PSEN}	–	10	–	10	ns
External data memory						
t_{RR}	RD pulse duration	275	–	$6t_{CLK} - 100$	–	ns
t_{WW}	WR pulse duration	275	–	$6t_{CLK} - 100$	–	ns
t_{AL}	address set-up time to ALE	8	–	$t_{CLK} - 55$	–	ns
t_{LA}	address hold time after ALE	28	–	$t_{CLK} - 35$	–	ns
t_{RD}	RD to valid data input	–	148	–	$5t_{CLK} - 165$	ns
t_{DR}	data hold time after \overline{RD}	0	–	0	–	ns
t_{DFR}	data float delay after \overline{RD}	–	55	–	$2t_{CLK} - 70$	ns
t_{LD}	time from ALE to valid data input	–	350	–	$8t_{CLK} - 150$	ns
t_{AD}	address to valid data input	–	398	–	$9t_{CLK} - 165$	ns
t_{LW}	time from ALE to \overline{RD} or \overline{WR}	138	238	$3t_{CLK} - 50$	$3t_{CLK} + 50$	ns
t_{AW}	time from address to \overline{RD} or \overline{WR}	120	–	$4t_{CLK} - 130$	–	ns
t_{WHLH}	time from \overline{RD} or \overline{WR} HIGH to ALE HIGH	23	103	$t_{CLK} - 40$	$t_{CLK} + 40$	ns
t_{DWX}	data valid to \overline{WR} transition	3	–	$t_{CLK} - 60$	–	ns
t_{DW}	data set-up time before \overline{WR}	288	–	$7t_{CLK} - 150$	–	ns
t_{WD}	data hold time after \overline{WR}	13	–	$t_{CLK} - 50$	–	ns
t_{AFR}	address float delay after \overline{RD}	–	0	–	0	ns

Note

- $t_{CLK} = 1/f_{osc} =$ one oscillator clock period. If $f_{osc} = 16$ MHz then $t_{CLK} = 62.5$ ns.

8-bit microcontroller

P83C562; P80C562

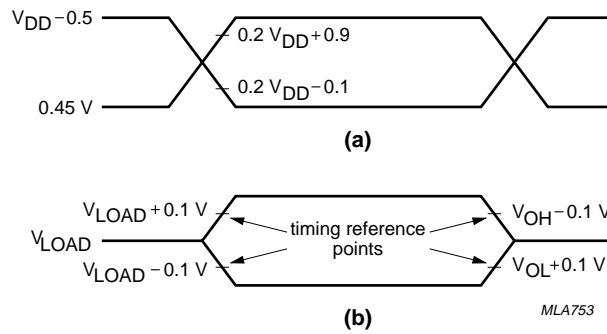

AC inputs during testing are driven at $V_{DD} - 0.5$ V for a logic 1, and 0.45 V for a logic 0.

Timing measurements are made at $V_{IH(min)}$ for a logic 1, and $V_{IL(max)}$ for a logic 0. See Fig.25 (a).

For timing purposes a port pin is no longer floating when a 100 mV change from load voltage occurs. A port pin begins to float when a 100 mV change from the loaded V_{OH}/V_{OL} level occurs. $I_{OL}/I_{OH} \geq \pm 20$ mA (for testing purposes only). See Fig.25 (b).

Fig.20 AC inputs test conditions.

8-bit microcontroller

P83C562; P80C562

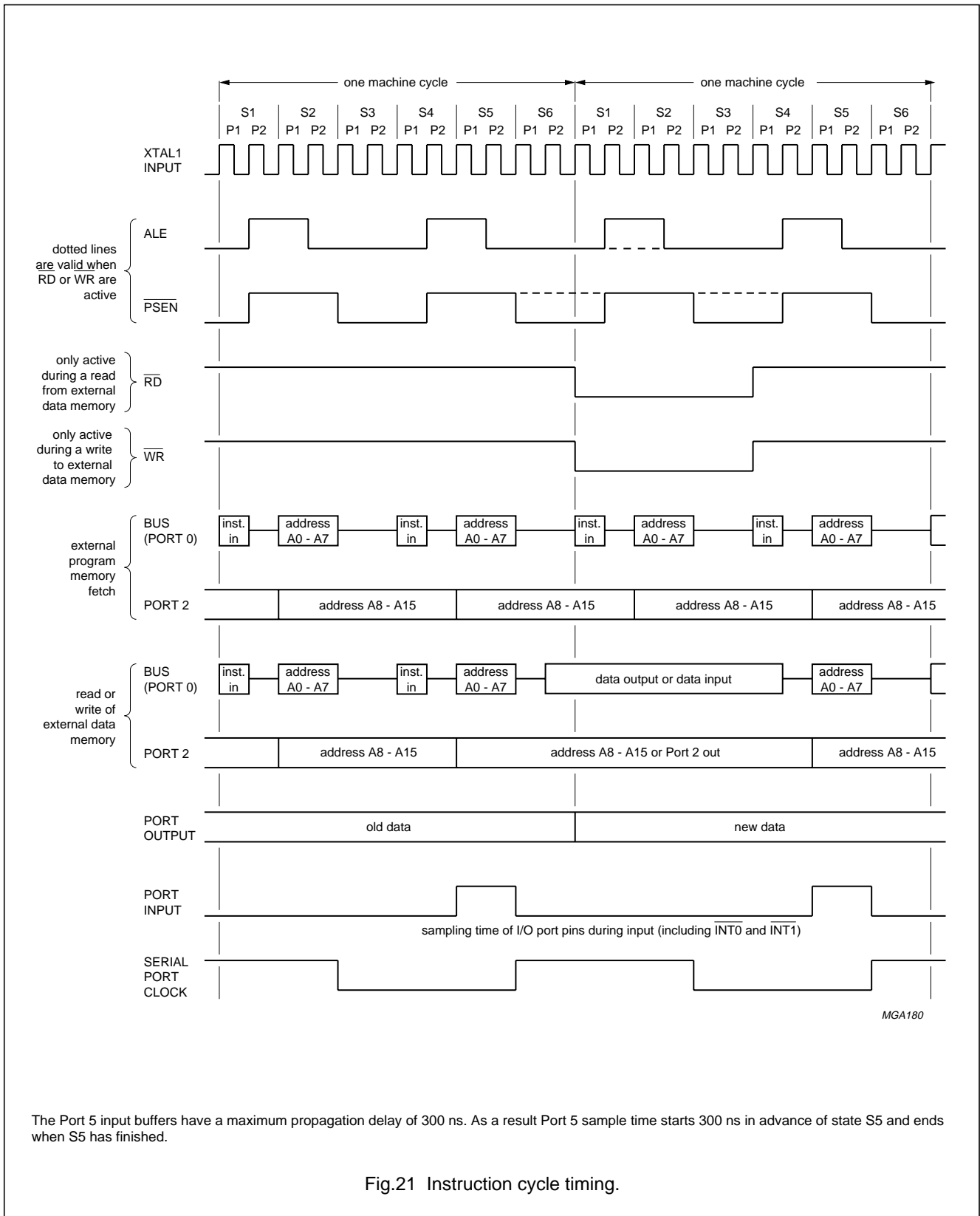

The Port 5 input buffers have a maximum propagation delay of 300 ns. As a result Port 5 sample time starts 300 ns in advance of state S5 and ends when S5 has finished.

Fig.21 Instruction cycle timing.

8-bit microcontroller

P83C562; P80C562

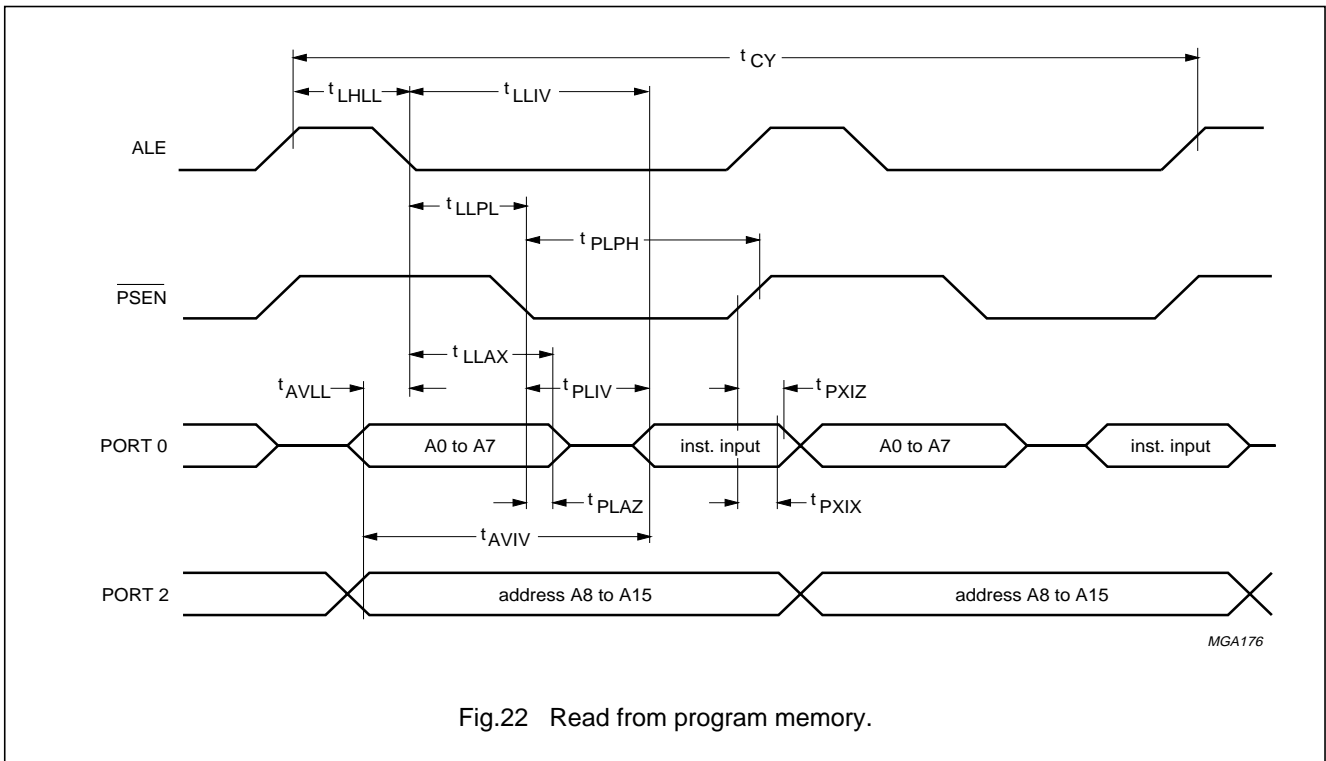

Fig.22 Read from program memory.

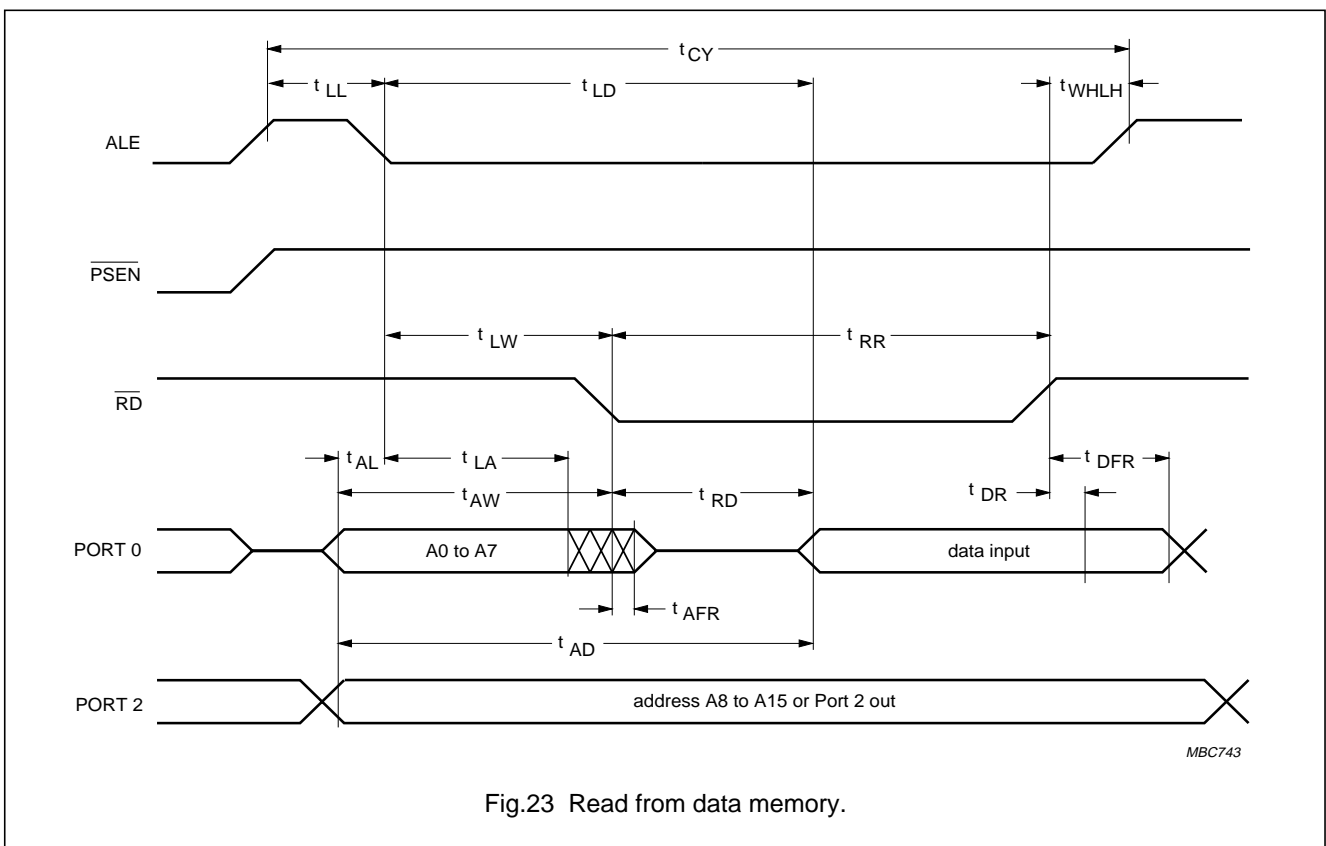

Fig.23 Read from data memory.

8-bit microcontroller

P83C562; P80C562

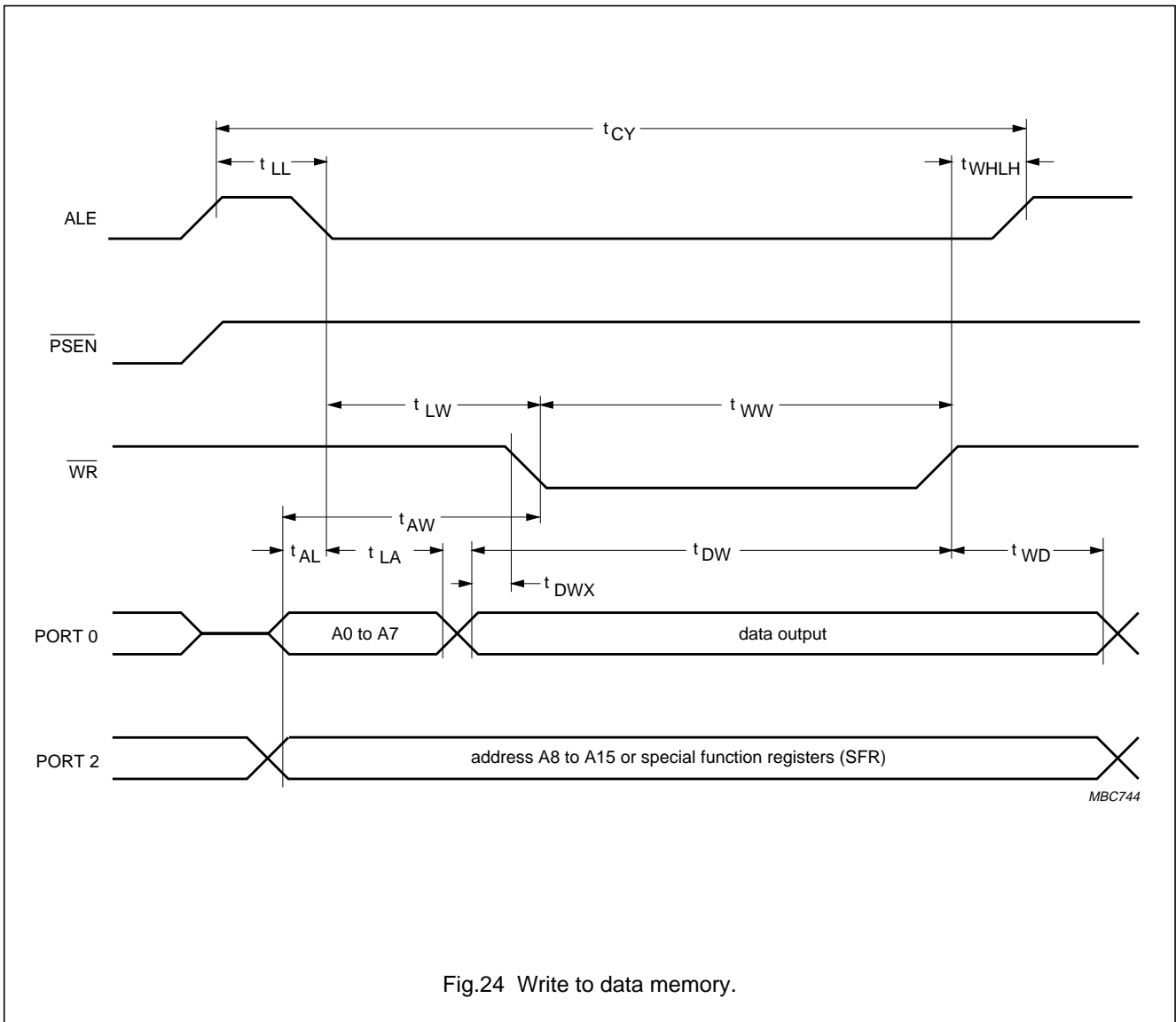

Fig.24 Write to data memory.

8-bit microcontroller

P83C562; P80C562

Table 44 External clock drive XTAL1

Test conditions: operating temperature and supply voltage ranges; load capacitance = 80 pF.

SYMBOL	PARAMETER	MIN.	MAX.	UNIT
t_{CLK}	clock period	62.5	285.7	ns
t_{HIGH}	HIGH time	20	–	ns
t_{LOW}	LOW time	20	–	ns
t_r	rise time	–	20	ns
t_f	fall time	–	20	ns
t_{CY}	cycle time (12 t_{CLK})	0.75	3.43	μ s

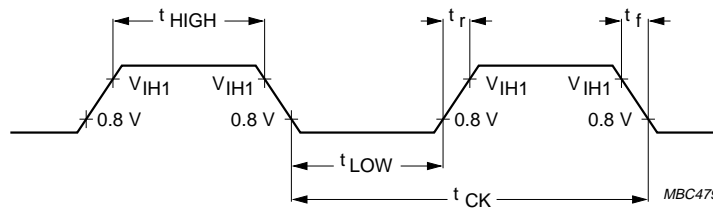

Fig.25 External clock drive XTAL.

Table 45 Serial timing - shift register mode using 16 MHz oscillator

SYMBOL	PARAMETER	16 MHz OSC		VARIABLE OSCILLATOR		UNIT
		MIN.	MAX.	MIN.	MAX.	
t_{XLXL}	serial port clock cycle time	0.75	–	$12t_{CLK}$	–	μ s
t_{QVXH}	output data set-up to clock rising edge	492	–	$10t_{CLK} - 133$	–	ns
t_{XHGX}	output data hold after clock rising edge	8.0	–	$2t_{CLK} - 117$	–	ns
t_{XHDX}	input data hold after clock rising edge	0	–	0	–	ns
t_{XHDV}	clock rising edge to input data valid	–	492	–	$10t_{CLK} - 133$	ns

8-bit microcontroller

P83C562; P80C562

22 PACKAGE OUTLINE

PLCC68: plastic leaded chip carrier; 68 leads

SOT188-2

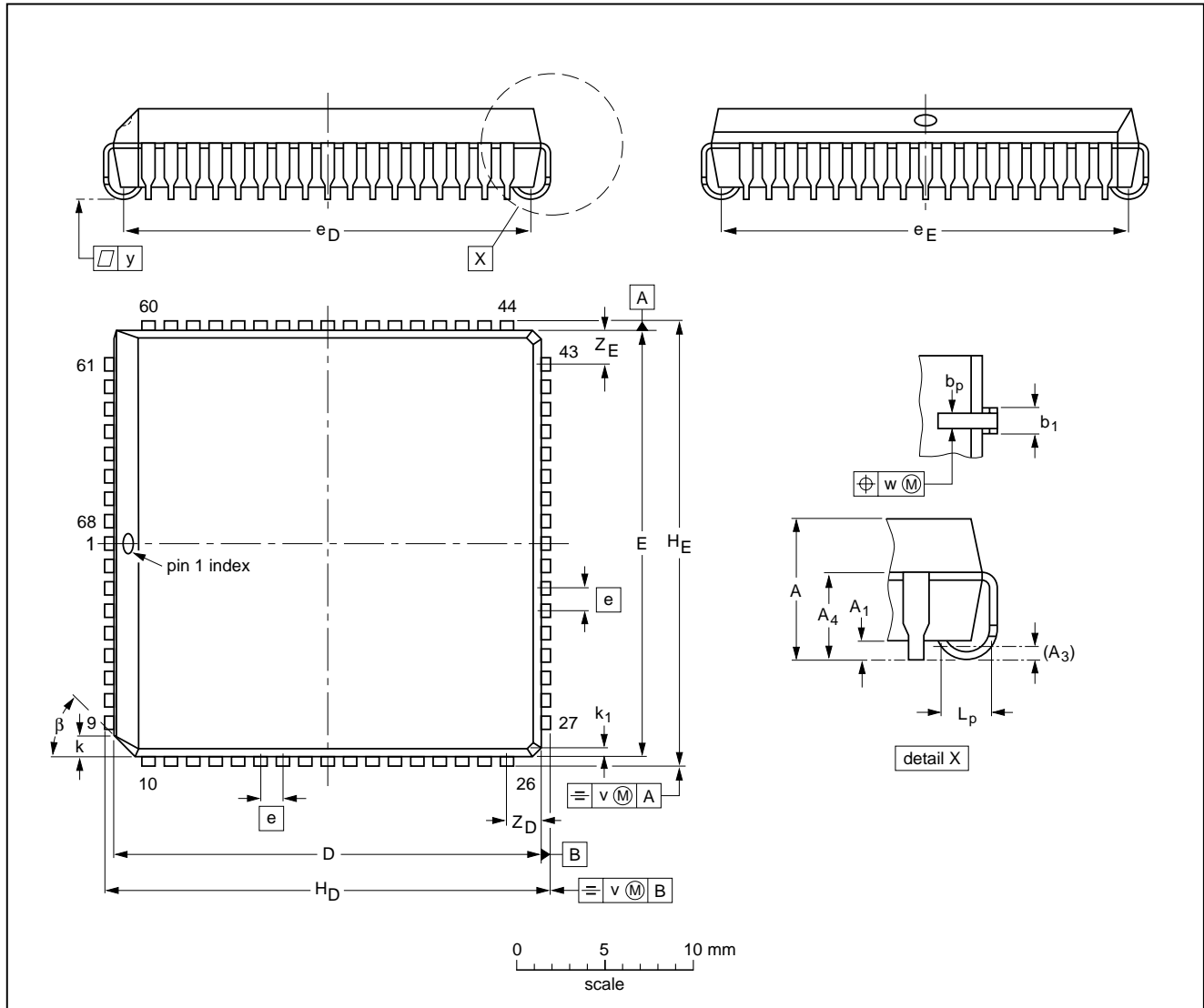

DIMENSIONS (millimetre dimensions are derived from the original inch dimensions)

UNIT	A	A ₁ min.	A ₃	A ₄ max.	b _p	b ₁	D ⁽¹⁾	E ⁽¹⁾	e	e _D	e _E	H _D	H _E	k	k ₁ max.	L _p	v	w	y	Z _D ⁽¹⁾ max.	Z _E ⁽¹⁾ max.	β
mm	4.57 4.19	0.51	0.25	3.30	0.53 0.33	0.81 0.66	24.33 24.13	24.33 24.13	1.27	23.62 22.61	23.62 22.61	25.27 25.02	25.27 25.02	1.22 1.07	0.51	1.44 1.02	0.18	0.18	0.10	2.16	2.16	45°
inches	0.180 0.165	0.020	0.01	0.13	0.021 0.013	0.032 0.026	0.958 0.950	0.958 0.950	0.05	0.930 0.890	0.930 0.890	0.995 0.985	0.995 0.985	0.048 0.042	0.020	0.057 0.040	0.007	0.007	0.004	0.085	0.085	

Note
1. Plastic or metal protrusions of 0.01 inches maximum per side are not included.

OUTLINE VERSION	REFERENCES				EUROPEAN PROJECTION	ISSUE DATE
	IEC	JEDEC	EIAJ			
SOT188-2	112E10	MO-047AC				92-11-17 95-03-11

8-bit microcontroller

P83C562; P80C562

23 SOLDERING

23.1 Introduction

There is no soldering method that is ideal for all IC packages. Wave soldering is often preferred when through-hole and surface mounted components are mixed on one printed-circuit board. However, wave soldering is not always suitable for surface mounted ICs, or for printed-circuits with high population densities. In these situations reflow soldering is often used.

This text gives a very brief insight to a complex technology. A more in-depth account of soldering ICs can be found in our *"IC Package Databook"* (order code 9398 652 90011).

23.2 Reflow soldering

Reflow soldering techniques are suitable for all PLCC packages.

The choice of heating method may be influenced by larger PLCC packages (44 leads, or more). If infrared or vapour phase heating is used and the large packages are not absolutely dry (less than 0.1% moisture content by weight), vaporization of the small amount of moisture in them can cause cracking of the plastic body. For more information, refer to the Drypack chapter in our *"Quality Reference Handbook"* (order code 9397 750 00192).

Reflow soldering requires solder paste (a suspension of fine solder particles, flux and binding agent) to be applied to the printed-circuit board by screen printing, stencilling or pressure-syringe dispensing before package placement.

Several techniques exist for reflowing; for example, thermal conduction by heated belt. Dwell times vary between 50 and 300 seconds depending on heating method. Typical reflow temperatures range from 215 to 250 °C.

Preheating is necessary to dry the paste and evaporate the binding agent. Preheating duration: 45 minutes at 45 °C.

23.3 Wave soldering

Wave soldering techniques can be used for all PLCC packages if the following conditions are observed:

- A double-wave (a turbulent wave with high upward pressure followed by a smooth laminar wave) soldering technique should be used.
- The longitudinal axis of the package footprint must be parallel to the solder flow.
- The package footprint must incorporate solder thieves at the downstream corners.

During placement and before soldering, the package must be fixed with a droplet of adhesive. The adhesive can be applied by screen printing, pin transfer or syringe dispensing. The package can be soldered after the adhesive is cured.

Maximum permissible solder temperature is 260 °C, and maximum duration of package immersion in solder is 10 seconds, if cooled to less than 150 °C within 6 seconds. Typical dwell time is 4 seconds at 250 °C.

A mildly-activated flux will eliminate the need for removal of corrosive residues in most applications.

23.4 Repairing soldered joints

Fix the component by first soldering two diagonally-opposite end leads. Use only a low voltage soldering iron (less than 24 V) applied to the flat part of the lead. Contact time must be limited to 10 seconds at up to 300 °C. When using a dedicated tool, all other leads can be soldered in one operation within 2 to 5 seconds between 270 and 320 °C.

8-bit microcontroller

P83C562; P80C562

24 DEFINITIONS

Data sheet status	
Objective specification	This data sheet contains target or goal specifications for product development.
Preliminary specification	This data sheet contains preliminary data; supplementary data may be published later.
Product specification	This data sheet contains final product specifications.
Limiting values	
Limiting values given are in accordance with the Absolute Maximum Rating System (IEC 134). Stress above one or more of the limiting values may cause permanent damage to the device. These are stress ratings only and operation of the device at these or at any other conditions above those given in the Characteristics sections of this specification is not implied. Exposure to limiting values for extended periods may affect device reliability.	
Application information	
Where application information is given, it is advisory and does not form part of the specification.	

25 LIFE SUPPORT APPLICATIONS

These products are not designed for use in life support appliances, devices, or systems where malfunction of these products can reasonably be expected to result in personal injury. Philips customers using or selling these products for use in such applications do so at their own risk and agree to fully indemnify Philips for any damages resulting from such improper use or sale.

Philips Semiconductors – a worldwide company

Argentina: see South America

Australia: 34 Waterloo Road, NORTH RYDE, NSW 2113,
Tel. +61 2 9805 4455, Fax. +61 2 9805 4466

Austria: Computerstr. 6, A-1101 WIEN, P.O. Box 213,
Tel. +43 1 60 101, Fax. +43 1 60 101 1210

Belarus: Hotel Minsk Business Center, Bld. 3, r. 1211, Volodarski Str. 6,
220050 MINSK, Tel. +375 172 200 733, Fax. +375 172 200 773

Belgium: see The Netherlands

Brazil: see South America

Bulgaria: Philips Bulgaria Ltd., Energoproject, 15th floor,
51 James Bourchier Blvd., 1407 SOFIA,
Tel. +359 2 689 211, Fax. +359 2 689 102

Canada: PHILIPS SEMICONDUCTORS/COMPONENTS,
Tel. +1 800 234 7381

China/Hong Kong: 501 Hong Kong Industrial Technology Centre,
72 Tat Chee Avenue, Kowloon Tong, HONG KONG,
Tel. +852 2319 7888, Fax. +852 2319 7700

Colombia: see South America

Czech Republic: see Austria

Denmark: Prags Boulevard 80, PB 1919, DK-2300 COPENHAGEN S,
Tel. +45 32 88 2636, Fax. +45 31 57 0044

Finland: Sinikalliontie 3, FIN-02630 ESPOO,
Tel. +358 9 615800, Fax. +358 9 61580920

France: 4 Rue du Port-aux-Vins, BP317, 92156 SURESNES Cedex,
Tel. +33 1 40 99 6161, Fax. +33 1 40 99 6427

Germany: Hammerbrookstraße 69, D-20097 HAMBURG,
Tel. +49 40 23 53 60, Fax. +49 40 23 536 300

Greece: No. 15, 25th March Street, GR 17778 TAVROS/ATHENS,
Tel. +30 1 4894 339/239, Fax. +30 1 4814 240

Hungary: see Austria

India: Philips INDIA Ltd, Shivsagar Estate, A Block, Dr. Annie Besant Rd.
Worli, MUMBAI 400 018, Tel. +91 22 4938 541, Fax. +91 22 4938 722

Indonesia: see Singapore

Ireland: Newstead, Clonskeagh, DUBLIN 14,
Tel. +353 1 7640 000, Fax. +353 1 7640 200

Israel: RAPAC Electronics, 7 Kehilat Saloniki St, PO Box 18053,
TEL AVIV 61180, Tel. +972 3 645 0444, Fax. +972 3 649 1007

Italy: PHILIPS SEMICONDUCTORS, Piazza IV Novembre 3,
20124 MILANO, Tel. +39 2 6752 2531, Fax. +39 2 6752 2557

Japan: Philips Bldg 13-37, Kohnan 2-chome, Minato-ku, TOKYO 108,
Tel. +81 3 3740 5130, Fax. +81 3 3740 5077

Korea: Philips House, 260-199 Itaewon-dong, Yongsan-ku, SEOUL,
Tel. +82 2 709 1412, Fax. +82 2 709 1415

Malaysia: No. 76 Jalan Universiti, 46200 PETALING JAYA, SELANGOR,
Tel. +60 3 750 5214, Fax. +60 3 757 4880

Mexico: 5900 Gateway East, Suite 200, EL PASO, TEXAS 79905,
Tel. +9-5 800 234 7381

Middle East: see Italy

Netherlands: Postbus 90050, 5600 PB EINDHOVEN, Bldg. VB,
Tel. +31 40 27 82785, Fax. +31 40 27 88399

New Zealand: 2 Wagener Place, C.P.O. Box 1041, AUCKLAND,
Tel. +64 9 849 4160, Fax. +64 9 849 7811

Norway: Box 1, Manglerud 0612, OSLO,
Tel. +47 22 74 8000, Fax. +47 22 74 8341

Philippines: Philips Semiconductors Philippines Inc.,
106 Valero St. Salcedo Village, P.O. Box 2108 MCC, MAKATI,
Metro MANILA, Tel. +63 2 816 6380, Fax. +63 2 817 3474

Poland: Ul. Lukiska 10, PL 04-123 WARSZAWA,
Tel. +48 22 612 2831, Fax. +48 22 612 2327

Portugal: see Spain

Romania: see Italy

Russia: Philips Russia, Ul. Usatcheva 35A, 119048 MOSCOW,
Tel. +7 095 755 6918, Fax. +7 095 755 6919

Singapore: Lorong 1, Toa Payoh, SINGAPORE 1231,
Tel. +65 350 2538, Fax. +65 251 6500

Slovakia: see Austria

Slovenia: see Italy

South Africa: S.A. PHILIPS Pty Ltd., 195-215 Main Road Martindale,
2092 JOHANNESBURG, P.O. Box 7430 Johannesburg 2000,
Tel. +27 11 470 5911, Fax. +27 11 470 5494

South America: Rua do Rocio 220, 5th floor, Suite 51,
04552-903 São Paulo, SÃO PAULO - SP, Brazil,
Tel. +55 11 821 2333, Fax. +55 11 829 1849

Spain: Balmes 22, 08007 BARCELONA,
Tel. +34 3 301 6312, Fax. +34 3 301 4107

Sweden: Kottbygatan 7, Akalla, S-16485 STOCKHOLM,
Tel. +46 8 632 2000, Fax. +46 8 632 2745

Switzerland: Allmendstrasse 140, CH-8027 ZÜRICH,
Tel. +41 1 488 2686, Fax. +41 1 481 7730

Taiwan: Philips Semiconductors, 6F, No. 96, Chien Kuo N. Rd., Sec. 1,
TAIPEI, Taiwan Tel. +886 2 2134 2865, Fax. +886 2 2134 2874

Thailand: PHILIPS ELECTRONICS (THAILAND) Ltd.,
209/2 Sanpavuth-Bangna Road Prakanong, BANGKOK 10260,
Tel. +66 2 745 4090, Fax. +66 2 398 0793

Turkey: Talatpasa Cad. No. 5, 80640 GÜLTEPE/ISTANBUL,
Tel. +90 212 279 2770, Fax. +90 212 282 6707

Ukraine: PHILIPS UKRAINE, 4 Patrice Lumumba str., Building B, Floor 7,
252042 KIEV, Tel. +380 44 264 2776, Fax. +380 44 268 0461

United Kingdom: Philips Semiconductors Ltd., 276 Bath Road, Hayes,
MIDDLESEX UB3 5BX, Tel. +44 181 730 5000, Fax. +44 181 754 8421

United States: 811 East Arques Avenue, SUNNYVALE, CA 94088-3409,
Tel. +1 800 234 7381

Uruguay: see South America

Vietnam: see Singapore

Yugoslavia: PHILIPS, Trg N. Pasica 5/v, 11000 BEOGRAD,
Tel. +381 11 625 344, Fax. +381 11 635 777

For all other countries apply to: Philips Semiconductors, Marketing & Sales Communications,
Building BE-p, P.O. Box 218, 5600 MD EINDHOVEN, The Netherlands, Fax. +31 40 27 24825

Internet: <http://www.semiconductors.philips.com>

© Philips Electronics N.V. 1997

SCA54

All rights are reserved. Reproduction in whole or in part is prohibited without the prior written consent of the copyright owner.

The information presented in this document does not form part of any quotation or contract, is believed to be accurate and reliable and may be changed without notice. No liability will be accepted by the publisher for any consequence of its use. Publication thereof does not convey nor imply any license under patent- or other industrial or intellectual property rights.

Printed in The Netherlands

457047/1200/01/pp52

Date of release: 1997 Apr 08

Document order number: 9397 750 02133

Let's make things better.

**Philips
Semiconductors**



PHILIPS