

# DATA SHEET

For a complete data sheet, please also download:

- The IC04 LOCMOS HE4000B Logic Family Specifications HEF, HEC
- The IC04 LOCMOS HE4000B Logic Package Outlines/Information HEF, HEC

## **HEF4077B**

### **gates**

### **Quadruple exclusive-NOR gate**

Product specification  
File under Integrated Circuits, IC04

January 1995

# Quadruple exclusive-NOR gate

# HEF4077B gates

### DESCRIPTION

The HEF4077B provides the exclusive-NOR function. The outputs are fully buffered for best performance.

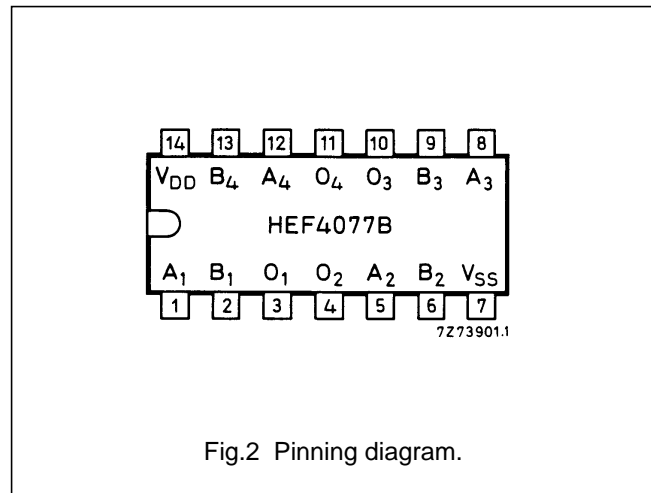
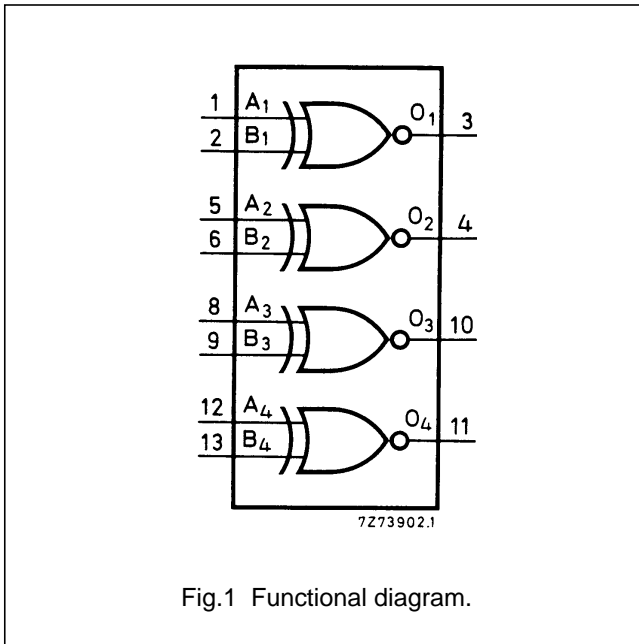

- HEF4077BP(N): 14-lead DIL; plastic (SOT27-1)
- HEF4077BD(F): 14-lead DIL; ceramic (cerdip) (SOT73)
- HEF4077BT(D): 14-lead SO; plastic (SOT108-1)
- ( ): Package Designator North America

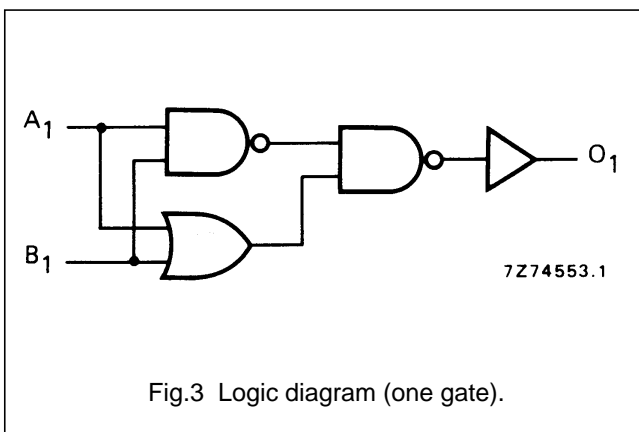

### TRUTH TABLE

A <sub>n</sub>	B <sub>n</sub>	O <sub>n</sub>
L	L	H
L	H	L
H	L	L
H	H	H

### Note

1. H = HIGH state (the more positive voltage)  
L = LOW state (the less positive voltage)

### FAMILY DATA, I<sub>DD</sub> LIMITS category GATES

See Family Specifications

# Quadruple exclusive-NOR gate

## HEF4077B gates

### AC CHARACTERISTICS

$V_{SS} = 0$  V;  $T_{amb} = 25$  °C;  $C_L = 50$  pF; input transition times  $\leq 20$  ns

	$V_{DD}$ V	SYMBOL	TYP. MAX.			TYPICAL EXTRAPOLATION FORMULA	
Propagation delays $A_n, B_n \rightarrow O_n$ HIGH to LOW	5	$t_{PHL}$	75	150	ns	$48 \text{ ns} + (0,55 \text{ ns/pF}) C_L$	
	10		35	70	ns	$24 \text{ ns} + (0,23 \text{ ns/pF}) C_L$	
	15		30	55	ns	$22 \text{ ns} + (0,16 \text{ ns/pF}) C_L$	
	LOW to HIGH	5	$t_{PLH}$	70	145	ns	$43 \text{ ns} + (0,55 \text{ ns/pF}) C_L$
		10		30	60	ns	$19 \text{ ns} + (0,23 \text{ ns/pF}) C_L$
		15		25	50	ns	$17 \text{ ns} + (0,16 \text{ ns/pF}) C_L$
Output transition times HIGH to LOW	5	$t_{THL}$	60	120	ns	$10 \text{ ns} + (1,0 \text{ ns/pF}) C_L$	
	10		30	60	ns	$9 \text{ ns} + (0,42 \text{ ns/pF}) C_L$	
	15		20	40	ns	$6 \text{ ns} + (0,28 \text{ ns/pF}) C_L$	
	LOW to HIGH	5	$t_{TLH}$	60	120	ns	$10 \text{ ns} + (1,0 \text{ ns/pF}) C_L$
		10		30	60	ns	$9 \text{ ns} + (0,42 \text{ ns/pF}) C_L$
		15		20	40	ns	$6 \text{ ns} + (0,28 \text{ ns/pF}) C_L$

	$V_{DD}$ V	TYPICAL FORMULA FOR P( $\mu$ W)	
Dynamic power dissipation per package (P)	5	$850 f_i + \sum (f_o C_L) \times V_{DD}^2$	where $f_i$ = input freq. (MHz) $f_o$ = output freq. (MHz) $C_L$ = load capacitance (pF) $\sum (f_o C_L)$ = sum of outputs $V_{DD}$ = supply voltage (V)
	10	$4\,500 f_i + \sum (f_o C_L) \times V_{DD}^2$	
	15	$14\,700 f_i + \sum (f_o C_L) \times V_{DD}^2$	