

DATA SHEET

For a complete data sheet, please also download:

- The IC06 74HC/HCT/HCU/HCMOS Logic Family Specifications
- The IC06 74HC/HCT/HCU/HCMOS Logic Package Information
- The IC06 74HC/HCT/HCU/HCMOS Logic Package Outlines

74HC7014

Hex non-inverting precision
Schmitt-trigger

Product specification
Supersedes data of September 1993
File under Integrated Circuits, IC06

1998 Jul 08

Hex non-inverting precision Schmitt-trigger

74HC7014

FEATURES

- Operating voltage 3 to 6 V
- Output capability: standard
- category: SSI

APPLICATIONS

- Wave and pulse shapers for highly noisy environments

DESCRIPTION

The 74HC7014 is a high-speed Si-gate CMOS device. It is specified in compliance with JEDEC standard no. 7A.

The 74HC7014 provides six precision Schmitt-triggers with non-inverting buffers. It is capable of transforming slowly changing input signals into sharply defined, jitter-free output signals. The precisely defined trigger levels are lying in a window between $0.55 \times V_{CC}$ and $0.65 \times V_{CC}$. This makes the circuit suitable to operate in a highly noisy environment. Input shorts are allowed to -1.5 V and 16 V without disturbing other channels.

FUNCTION TABLE

INPUT	OUTPUT
nA	nY
L	L
H	H

Note

1. H = HIGH voltage level
L = LOW voltage level

QUICK REFERENCE DATA

GND = 0 V; $T_{amb} = 25$ °C; $t_r = t_f = 6$ ns

SYMBOL	PARAMETER	CONDITIONS	TYPICAL	UNIT
V_{T+}	positive going threshold	$C_L = 50$ pF; $V_{CC} = 5$ V	3.1	V
V_{T-}	negative going threshold		2.9	V
C_I	input capacitance		3.5	pF
C_{PD}	power dissipation capacitance per gate	notes 1 and 2	9	pF
I_{CC}	DC supply current		3.0	mA

Notes to the quick reference data

1. C_{PD} is used to determine the dynamic power dissipation (P_D in μ W):

$$P_D = C_{PD} \times V_{CC}^2 \times f_i + \sum (C_L \times V_{CC}^2 \times f_o)$$
 where:
 - f_i = input frequency in MHz.
 - f_o = output frequency in MHz.
 - C_L = output load capacitance in pF.
 - V_{CC} = supply voltage in V.
 - $\sum (C_L \times V_{CC}^2 \times f_o)$ = sum of outputs.
2. For HC the condition is $V_I = \text{GND to } V_{CC}$.

ORDERING INFORMATION

TYPE NUMBER	PACKAGE			
	PINS	PIN POSITION	MATERIAL	CODE
74HC7014N	14	DIP	plastic	SOT27-1
74HC7014D	14	SO	plastic	SOT108-1

Hex non-inverting precision Schmitt-trigger

74HC7014

PINNING

PIN NO.	SYMBOL	NAME AND FUNCTION
1, 3, 5, 9, 11, 13	1A to 6A	data inputs
2, 4, 6, 8, 10, 12	1Y to 6Y	data outputs
7	GND	ground (0 V)
14	V _{CC}	positive supply voltage

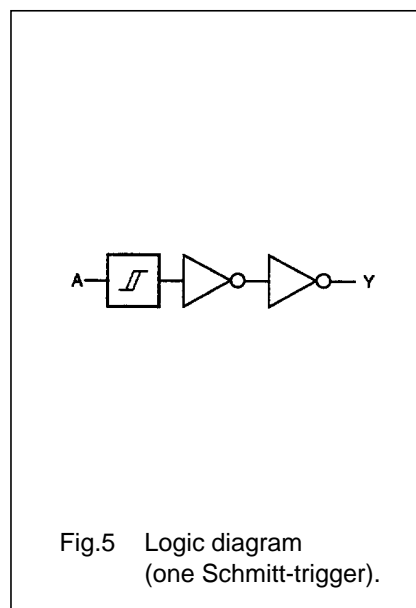
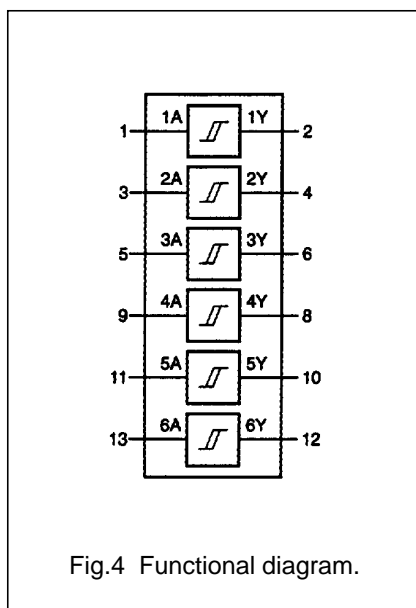
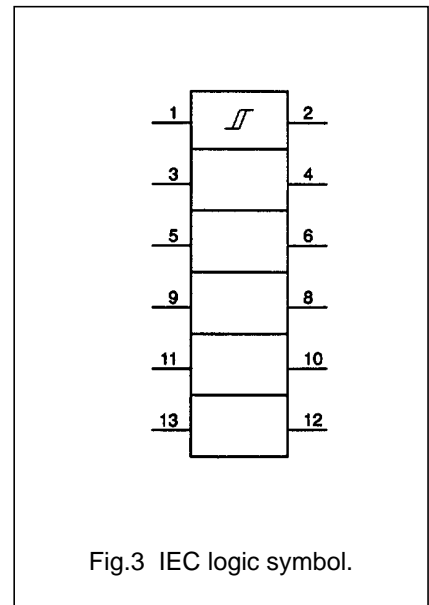
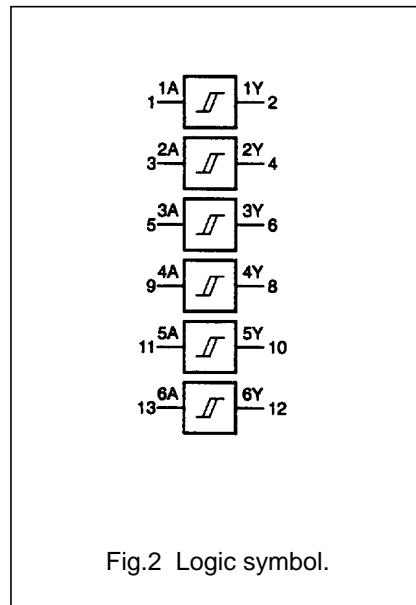
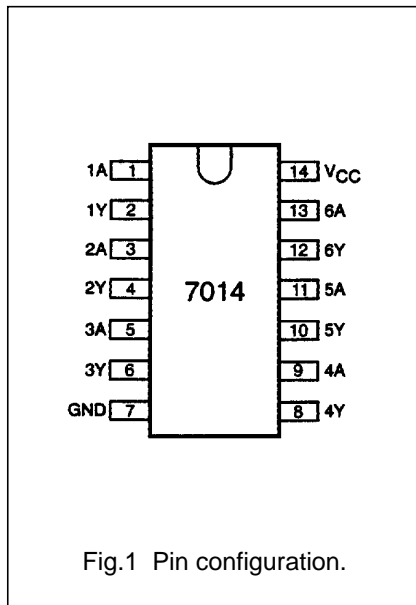

Hex non-inverting precision Schmitt-trigger

74HC7014

DC CHARACTERISTICS FOR 74HC

For the DC characteristics see *"74HC/HCT/HCU/HCMOS Logic Family Specifications"*.

Output capability: standard

Category: SSI

TRANSFER CHARACTERISTICS FOR 74HC

Voltages are referenced to GND (ground = 0 V)

SYMBOL	PARAMETER	T _{amb} (°C)								UNIT	TEST CONDITIONS		
		+25			-40 to +85		-40 to +125		V _{CC} (V)		V _I (V)	OTHER	
		MIN.	TYP.	MAX.	MIN.	MAX.	MIN.	MAX.					
V _{T+}	positive-going threshold	-	1.86	1.95	-	1.95	-	1.95	V	3.00		Figs.6 and 7	
		-	2.94	3.08	-	3.08	-	3.08					
		-	3.10	3.25	-	3.25	-	3.25					
		-	3.25	3.41	-	3.41	-	3.41					
		-	3.72	3.90	-	3.90	-	3.90					
V _{T-}	negative-going threshold	1.65	1.74	-	1.65	-	1.65	-	V	3.00		Figs.6 and 7	
		2.62	2.76	-	2.62	-	2.62	-					
		2.75	2.90	-	2.75	-	2.75	-					
		2.89	3.05	-	2.89	-	2.89	-					
		3.30	3.48	-	3.30	-	3.30	-					
V _H	hysteresis (V _{T+} - V _{T-})	50	120	-	50	-	50	-	mV	3.00		Figs.6 and 7	
		100	180	-	100	-	100	-					
		120	200	-	120	-	120	-					
		130	210	-	130	-	130	-					
		160	240	-	160	-	160	-					
±I _I	input leakage current	-	-	0.1	-	1.0	-	1.0	µA	6.0	V _{CC} or GND		
		-	-	0.5	-	5.0	-	5.0					
I _{CC}	DC supply current	-	0.7	1.4	-	1.8	-	2.1	mA	3.00			
		-	3.0	6.0	-	7.5	-	7.5					
		-	3.7	7.4	-	10.0	-	13.0					

Hex non-inverting precision Schmitt-trigger

74HC7014

AC CHARACTERISTICS FOR 74HC

GND = 0 V; $t_r = t_f = 6$ ns; $C_L = 50$ pF

SYMBOL	PARAMETER	T_{amb} (°C)							UNIT	TEST CONDITIONS	
		+25			-40 to +85		-40 to +125			V_{CC} (V)	WAVEFORMS
		MIN.	TYP.	MAX.	MIN.	MAX.	MIN.	MAX.			
t_{PHL}	propagation delay nA, nB to nY	-	95	475	-	600	-	715	ns	3.00 4.75 6.00	Fig.8
t_{PLH}	propagation delay nA, nB to nY	-	47	175	-	220	-	260	ns	3.00 4.75 6.00	Fig.8
t_{THL}/t_{TLH}	output transition time	-	12	20	-	25	-	30	ns	3.00 4.75 6.00	Fig.8
		-	7	15	-	19	-	22			
		-	6	13	-	16	-	19			

TRANSFER CHARACTERISTIC WAVEFORMS

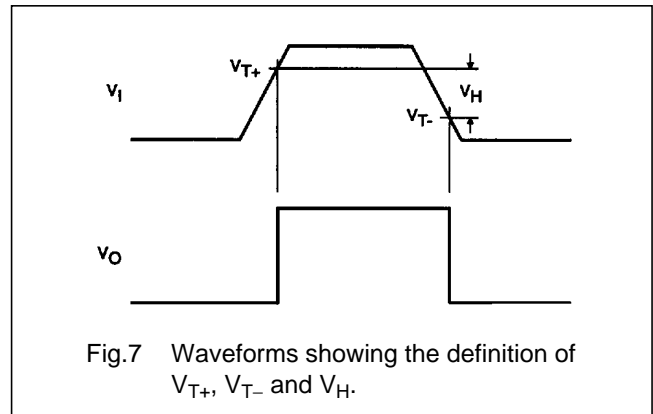
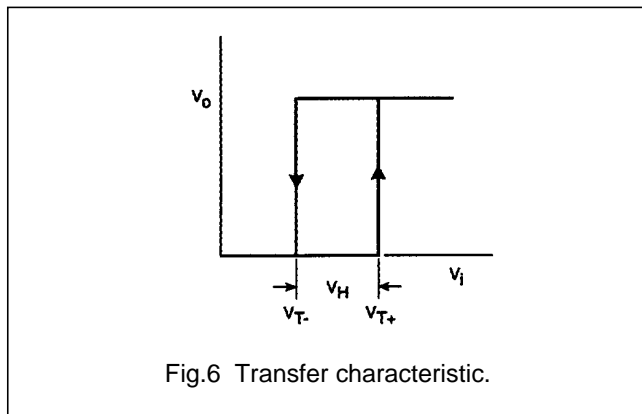

AC WAVEFORMS

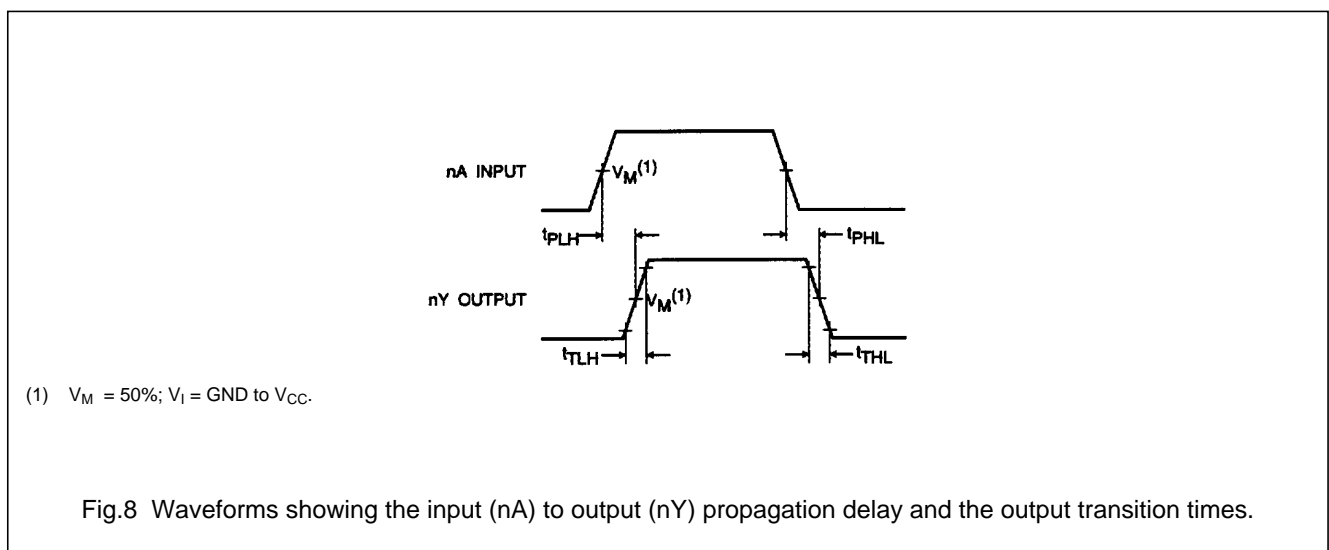

Hex non-inverting precision Schmitt-trigger

74HC7014

PACKAGE OUTLINES

DIP14: plastic dual in-line package; 14 leads (300 mil)

SOT27-1

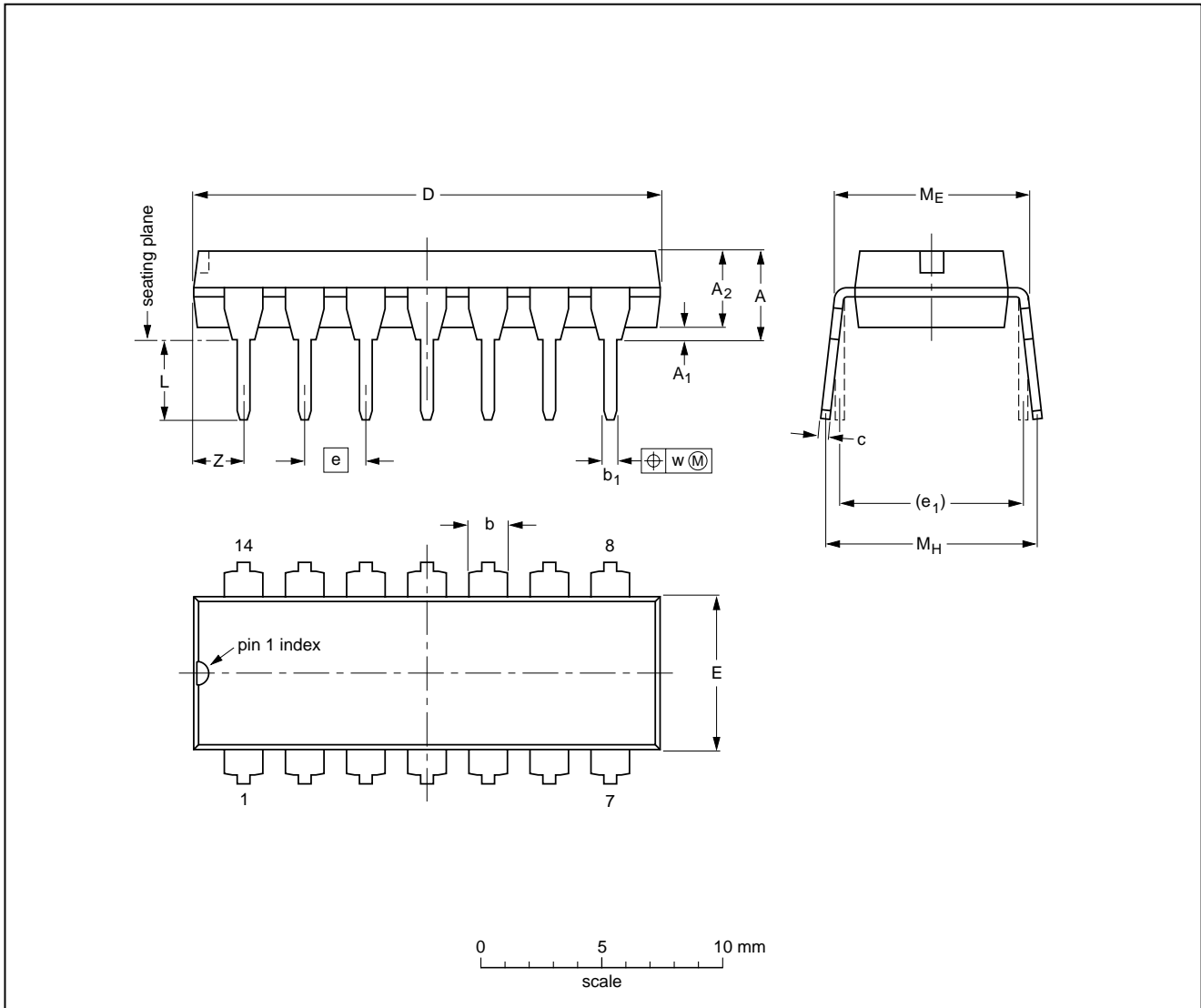

DIMENSIONS (inch dimensions are derived from the original mm dimensions)

UNIT	A max.	A ₁ min.	A ₂ max.	b	b ₁	c	D ⁽¹⁾	E ⁽¹⁾	e	e ₁	L	M _E	M _H	w	Z ⁽¹⁾ max.
mm	4.2	0.51	3.2	1.73 1.13	0.53 0.38	0.36 0.23	19.50 18.55	6.48 6.20	2.54	7.62	3.60 3.05	8.25 7.80	10.0 8.3	0.254	2.2
inches	0.17	0.020	0.13	0.068 0.044	0.021 0.015	0.014 0.009	0.77 0.73	0.26 0.24	0.10	0.30	0.14 0.12	0.32 0.31	0.39 0.33	0.01	0.087

Note

1. Plastic or metal protrusions of 0.25 mm maximum per side are not included.

OUTLINE VERSION	REFERENCES				EUROPEAN PROJECTION	ISSUE DATE
	IEC	JEDEC	EIAJ			
SOT27-1	050G04	MO-001AA				92-11-17 95-03-11

Hex non-inverting precision Schmitt-trigger

74HC7014

SO14: plastic small outline package; 14 leads; body width 3.9 mm

SOT108-1

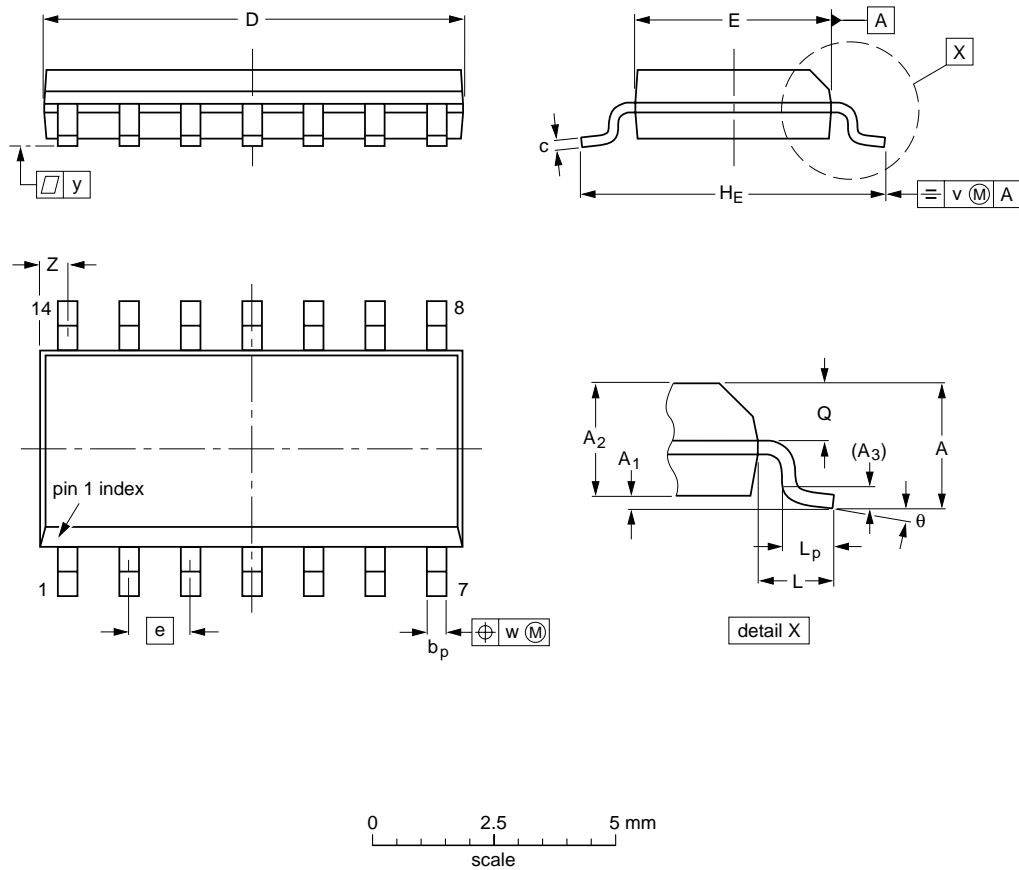

DIMENSIONS (inch dimensions are derived from the original mm dimensions)

UNIT	A max.	A ₁	A ₂	A ₃	b _p	c	D ⁽¹⁾	E ⁽¹⁾	e	H _E	L	L _p	Q	v	w	y	z ⁽¹⁾	θ
mm	1.75	0.25 0.10	1.45 1.25	0.25	0.49 0.36	0.25 0.19	8.75 8.55	4.0 3.8	1.27	6.2 5.8	1.05	1.0 0.4	0.7 0.6	0.25	0.25	0.1	0.7 0.3	8° 0°
inches	0.069	0.010 0.004	0.057 0.049	0.01	0.019 0.014	0.0100 0.0075	0.35 0.34	0.16 0.15	0.050	0.244 0.228	0.041	0.039 0.016	0.028 0.024	0.01	0.01	0.004	0.028 0.012	

Note

1. Plastic or metal protrusions of 0.15 mm maximum per side are not included.

OUTLINE VERSION	REFERENCES			EUROPEAN PROJECTION	ISSUE DATE
	IEC	JEDEC	EIAJ		
SOT108-1	076E06S	MS-012AB			95-01-23 97-05-22

Hex non-inverting precision Schmitt-trigger

74HC7014

SOLDERING

Introduction

There is no soldering method that is ideal for all IC packages. Wave soldering is often preferred when through-hole and surface mounted components are mixed on one printed-circuit board. However, wave soldering is not always suitable for surface mounted ICs, or for printed-circuits with high population densities. In these situations reflow soldering is often used.

This text gives a very brief insight to a complex technology. A more in-depth account of soldering ICs can be found in our *"Data Handbook IC26; Integrated Circuit Packages"* (order code 9398 652 90011).

DIP

SOLDERING BY DIPPING OR BY WAVE

The maximum permissible temperature of the solder is 260 °C; solder at this temperature must not be in contact with the joint for more than 5 seconds. The total contact time of successive solder waves must not exceed 5 seconds.

The device may be mounted up to the seating plane, but the temperature of the plastic body must not exceed the specified maximum storage temperature ($T_{stg\ max}$). If the printed-circuit board has been pre-heated, forced cooling may be necessary immediately after soldering to keep the temperature within the permissible limit.

REPAIRING SOLDERED JOINTS

Apply a low voltage soldering iron (less than 24 V) to the lead(s) of the package, below the seating plane or not more than 2 mm above it. If the temperature of the soldering iron bit is less than 300 °C it may remain in contact for up to 10 seconds. If the bit temperature is between 300 and 400 °C, contact may be up to 5 seconds.

SO

REFLOW SOLDERING

Reflow soldering techniques are suitable for all SO packages.

Reflow soldering requires solder paste (a suspension of fine solder particles, flux and binding agent) to be applied to the printed-circuit board by screen printing, stencilling or pressure-syringe dispensing before package placement.

Several techniques exist for reflowing; for example, thermal conduction by heated belt. Dwell times vary between 50 and 300 seconds depending on heating method. Typical reflow temperatures range from 215 to 250 °C.

Preheating is necessary to dry the paste and evaporate the binding agent. Preheating duration: 45 minutes at 45 °C.

WAVE SOLDERING

Wave soldering techniques can be used for all SO packages if the following conditions are observed:

- A double-wave (a turbulent wave with high upward pressure followed by a smooth laminar wave) soldering technique should be used.
- The longitudinal axis of the package footprint must be parallel to the solder flow.
- The package footprint must incorporate solder thieves at the downstream end.

During placement and before soldering, the package must be fixed with a droplet of adhesive. The adhesive can be applied by screen printing, pin transfer or syringe dispensing. The package can be soldered after the adhesive is cured.

Maximum permissible solder temperature is 260 °C, and maximum duration of package immersion in solder is 10 seconds, if cooled to less than 150 °C within 6 seconds. Typical dwell time is 4 seconds at 250 °C.

A mildly-activated flux will eliminate the need for removal of corrosive residues in most applications.

REPAIRING SOLDERED JOINTS

Fix the component by first soldering two diagonally-opposite end leads. Use only a low voltage soldering iron (less than 24 V) applied to the flat part of the lead. Contact time must be limited to 10 seconds at up to 300 °C. When using a dedicated tool, all other leads can be soldered in one operation within 2 to 5 seconds between 270 and 320 °C.

Hex non-inverting precision Schmitt-trigger

74HC7014

DEFINITIONS

Data sheet status	
Objective specification	This data sheet contains target or goal specifications for product development.
Preliminary specification	This data sheet contains preliminary data; supplementary data may be published later.
Product specification	This data sheet contains final product specifications.
Limiting values	
Limiting values given are in accordance with the Absolute Maximum Rating System (IEC 134). Stress above one or more of the limiting values may cause permanent damage to the device. These are stress ratings only and operation of the device at these or at any other conditions above those given in the Characteristics sections of the specification is not implied. Exposure to limiting values for extended periods may affect device reliability.	
Application information	
Where application information is given, it is advisory and does not form part of the specification.	

LIFE SUPPORT APPLICATIONS

These products are not designed for use in life support appliances, devices, or systems where malfunction of these products can reasonably be expected to result in personal injury. Philips customers using or selling these products for use in such applications do so at their own risk and agree to fully indemnify Philips for any damages resulting from such improper use or sale.