

# DATA SHEET

## **TDA8578**

Dual common-mode rejection  
differential line receiver

Product specification  
Supersedes data of November 1993  
File under Integrated Circuits, IC01

1995 Dec 15

## Dual common-mode rejection differential line receiver

### TDA8578

#### FEATURES

- Excellent common-mode rejection up to high frequencies
- Elimination of source resistance in the common-mode rejection
- Few external components
- High supply voltage ripple rejection
- Low noise
- Low distortion
- Protected against electrostatic discharge
- AC and DC short circuit safe to ground and  $V_{CC}$
- Fast DC settling.

#### APPLICATIONS

- Audio
- Car radio.

#### GENERAL DESCRIPTION

The TDA8578 is a two-channel differential amplifier in a 16 pin DIL or SO package intended to receive line inputs in audio applications requiring a high-level of common-mode rejection. The amplifier has a gain of 0 dB and a low distortion. The device is primarily developed for those car radio applications where long connections between signal sources and amplifiers (or boosters) are necessary and ground noise has to be eliminated.

#### QUICK REFERENCE DATA

SYMBOL	PARAMETER	CONDITIONS	MIN.	TYP.	MAX.	UNIT
$V_{CC}$	supply voltage		5	8.5	18	V
$I_{CC}$	supply current	$V_{CC} = 8.5\text{ V}$	–	11	14	mA
$G_v$	voltage gain		–0.5	0	+0.5	dB
SVRR	supply voltage ripple rejection		–55	–60	–	dB
$V_{no}$	noise output voltage		–	3.7	5	$\mu\text{V}$
$ Z_i $	input impedance		100	240	–	$\text{k}\Omega$
CMRR	common-mode rejection ratio	$R_s = 0\ \Omega$	–	80	–	dB

#### ORDERING INFORMATION

TYPE NUMBER	PACKAGE		
	NAME	DESCRIPTION	VERSION
TDA8578	DIP16	plastic dual in-line package; 16 leads (300 mil); long body	SOT38-1
TDA8578T	SO16	plastic small outline package; 16 leads; body width 3.9 mm	SOT109-1

# Dual common-mode rejection differential line receiver

## TDA8578

### BLOCK DIAGRAM

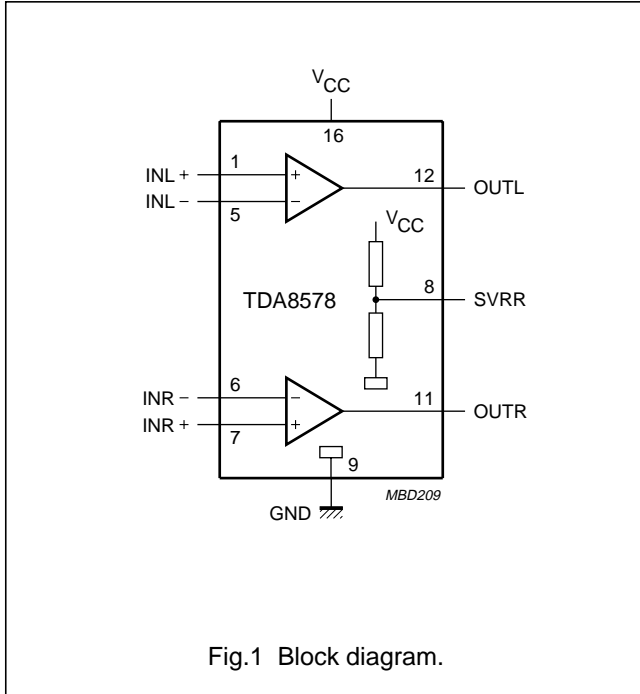

Fig.1 Block diagram.

### FUNCTIONAL DESCRIPTION

The TDA8578 contains two identical differential amplifiers with a voltage gain of 0 dB. The device is intended to receive line input signals. The device has a very high-level of common-mode rejection and it eliminates ground noise. The common-mode rejection keeps constant up to high frequencies. The gain of the amplifiers is fixed at 0 dB. The inputs have a high-input impedance and the output stage is a class AB stage with a low-output impedance. For a large common-mode rejection also at low frequencies, an electrolytic input capacitor at the negative input pin is advised. The input impedance is relative high, this would result in a large settling time of the DC input voltage. Therefore a quick charge circuit is included that charges the input capacitor within 0.2 s.

All input and output pins are protected against high electrostatic discharge conditions (4000 V, 150 pF, 150 Ω).

### PINNING

SYMBOL	PIN	DESCRIPTION
INL+	1	positive input left
n.c.	2	not connected
n.c.	3	not connected
n.c.	4	not connected
INL-	5	negative input left
INR-	6	negative input right
INR+	7	positive input right
SVRR	8	half supply voltage
GND	9	ground
n.c.	10	not connected
OUTR	11	output right
OUTL	12	output left
n.c.	13	not connected
n.c.	14	not connected
n.c.	15	not connected
V <sub>CC</sub>	16	supply voltage

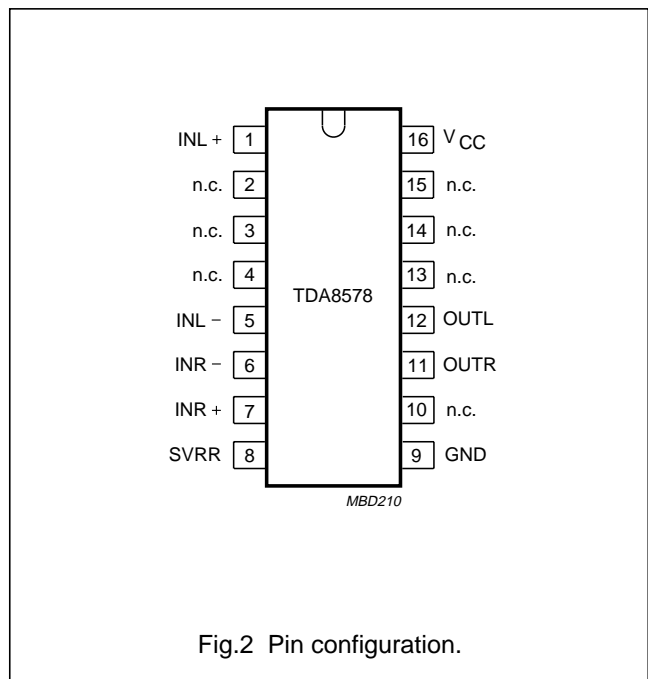

Fig.2 Pin configuration.

## Dual common-mode rejection differential line receiver

TDA8578

### LIMITING VALUES

In accordance with the Absolute Maximum Rating System (IEC 134).

SYMBOL	PARAMETER	CONDITIONS	MIN.	MAX.	UNIT
$V_{CC}$	supply voltage	operating	–	18	V
$I_{ORM}$	repetitive peak output current		–	40	mA
$V_{sc}$	AC and DC short-circuit safe voltage		–	18	V
$T_{stg}$	storage temperature		–55	+150	°C
$T_{amb}$	operating ambient temperature		–40	+85	°C
$T_j$	junction temperature		–	+150	°C

### HANDLING

Inputs and outputs are protected against electrostatic discharges in normal handling. However, to be totally safe, it is desirable to take normal precautions appropriate to handling integrated circuits.

### THERMAL CHARACTERISTICS

SYMBOL	PARAMETER	VALUE	UNIT
$R_{th\ j-a}$	thermal resistance from junction to ambient in free air		
	TDA8578 (DIP16)	75	K/W
	TDA8578T (SO16)	120	K/W

### DC CHARACTERISTICS

$V_{CC} = 8.5\text{ V}$ ;  $T_{amb} = 25\text{ °C}$ ; in accordance with test circuit (see Fig.3); unless otherwise specified.

SYMBOL	PARAMETER	CONDITIONS	MIN.	TYP.	MAX.	UNIT
$V_{CC}$	supply voltage		5	8.5	18	V
$I_{CC}$	supply current		–	11	14	mA
$V_O$	DC output voltage	note 1	–	4.3	–	V
$t_{set}$	DC input voltage settling time		–	0.2	–	s

### Note

1. The DC output voltage with respect to ground is approximately  $0.5V_{CC}$ .

## Dual common-mode rejection differential line receiver

TDA8578

### AC CHARACTERISTICS

$V_{CC} = 8.5 \text{ V}$ ;  $f = 1 \text{ kHz}$ ;  $T_{amb} = 25 \text{ }^\circ\text{C}$ ; in accordance with test circuit (see Fig.3); unless otherwise specified.

SYMBOL	PARAMETER	CONDITIONS	MIN.	TYP.	MAX.	UNIT
$G_v$	voltage gain		-0.5	0	+0.5	dB
$\alpha_{cs}$	channel separation	$R_s = 5 \text{ k}\Omega$	70	80	-	dB
$ \Delta G_v $	channel unbalance		-	-	0.5	dB
$f_L$	low frequency roll-off	-1 dB; note 1	20	-	-	Hz
$f_H$	high frequency roll-off	-1 dB	20	-	-	kHz
$ Z_i $	input impedance		100	240	-	$\text{k}\Omega$
$ Z_o $	output impedance		-	-	10	$\Omega$
$V_{i(max)}$	maximum input voltage	THD = 1%	-	2	-	V
$V_{no}$	noise output voltage	$R_s = 0 \text{ }\Omega$ ; note 2	-	3.7	5	$\mu\text{V}$
$V_{CM(rms)}$	common-mode input voltage (RMS value)		-	-	1	V
CMRR	common-mode rejection ratio	$R_s = 5 \text{ k}\Omega$	66	70	-	dB
		$R_s = 0 \text{ }\Omega$ ; note 3	-	80	-	dB
SVRR	supply voltage ripple rejection	note 4	55	65	-	dB
		note 5	-	60	-	dB
THD	total harmonic distortion	$V_i = 1 \text{ V}$	-	0.02	-	%
		$V_i = 1 \text{ V}$ ; $f = 20 \text{ Hz to } 20 \text{ kHz}$	-	-	0.1	%
$THD_{max}$	total harmonic distortion at maximum output current	$V_i = 1 \text{ V}$ ; $R_L = 150 \text{ }\Omega$	-	-	1	%

### Notes

- Frequency response externally fixed by the input coupling capacitors.
- Noise output voltage is measured in a bandwidth of 20 Hz to 20 kHz (unweighted).
- The common-mode rejection ratio is measured at the output, with a voltage source of 1 V (RMS), in accordance with test circuit (see Fig.3), while  $V_{INL}$  and  $V_{INR}$  are short-circuited. Frequencies between 100 Hz and 100 kHz.
- Ripple rejection is measured at the output, with  $R_s = 2 \text{ k}\Omega$ ;  $f = 1 \text{ kHz}$  and a ripple amplitude of 2 V (p-p).
- Ripple rejection is measured at the output, with  $R_s = 0 \text{ }\Omega$  up to 2  $\text{k}\Omega$  and  $f = 100 \text{ Hz to } 20 \text{ kHz}$ ; maximum ripple amplitude of 2 V (p-p).

# Dual common-mode rejection differential line receiver

TDA8578

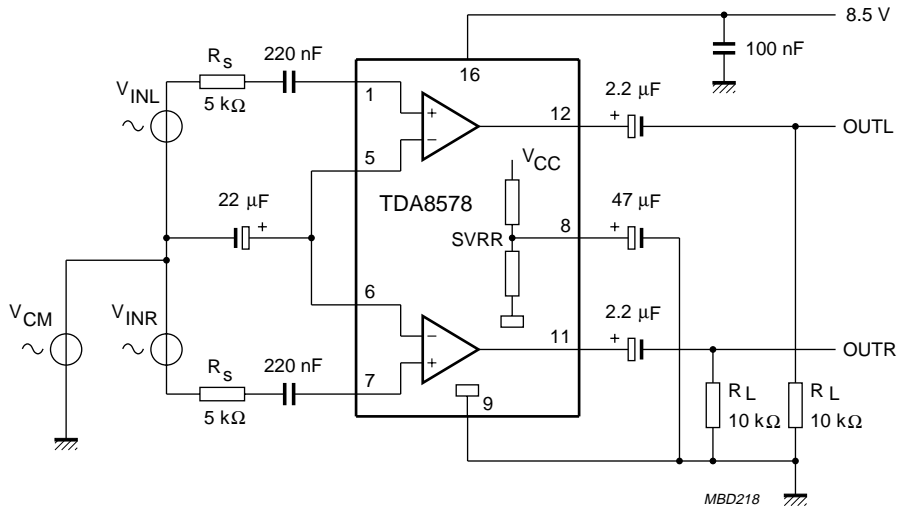

Fig.3 Test circuit.

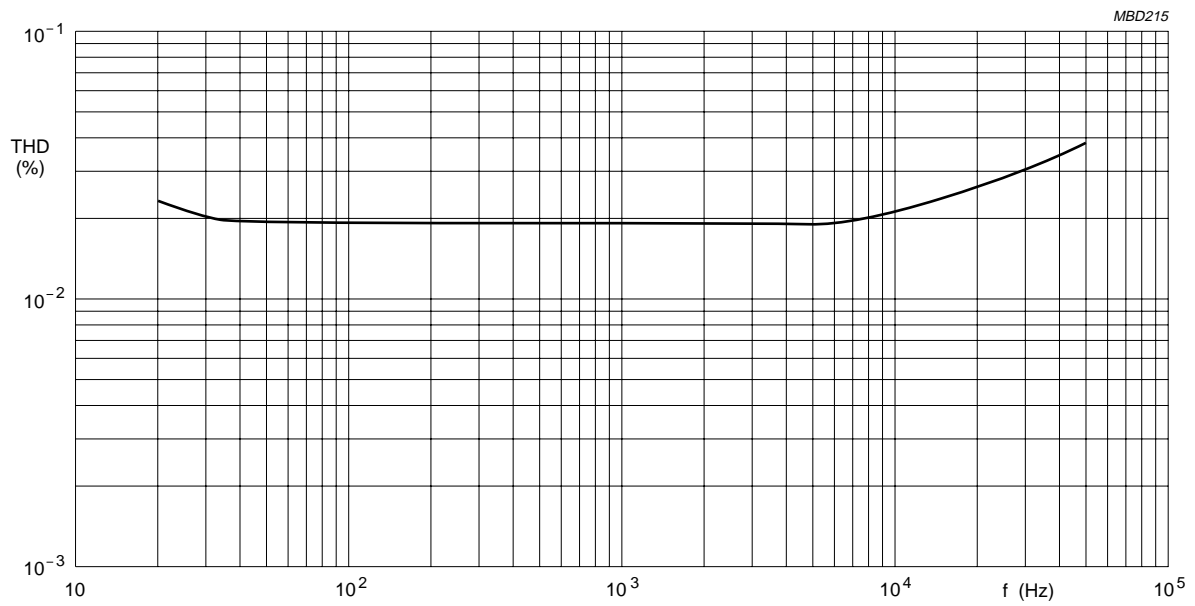
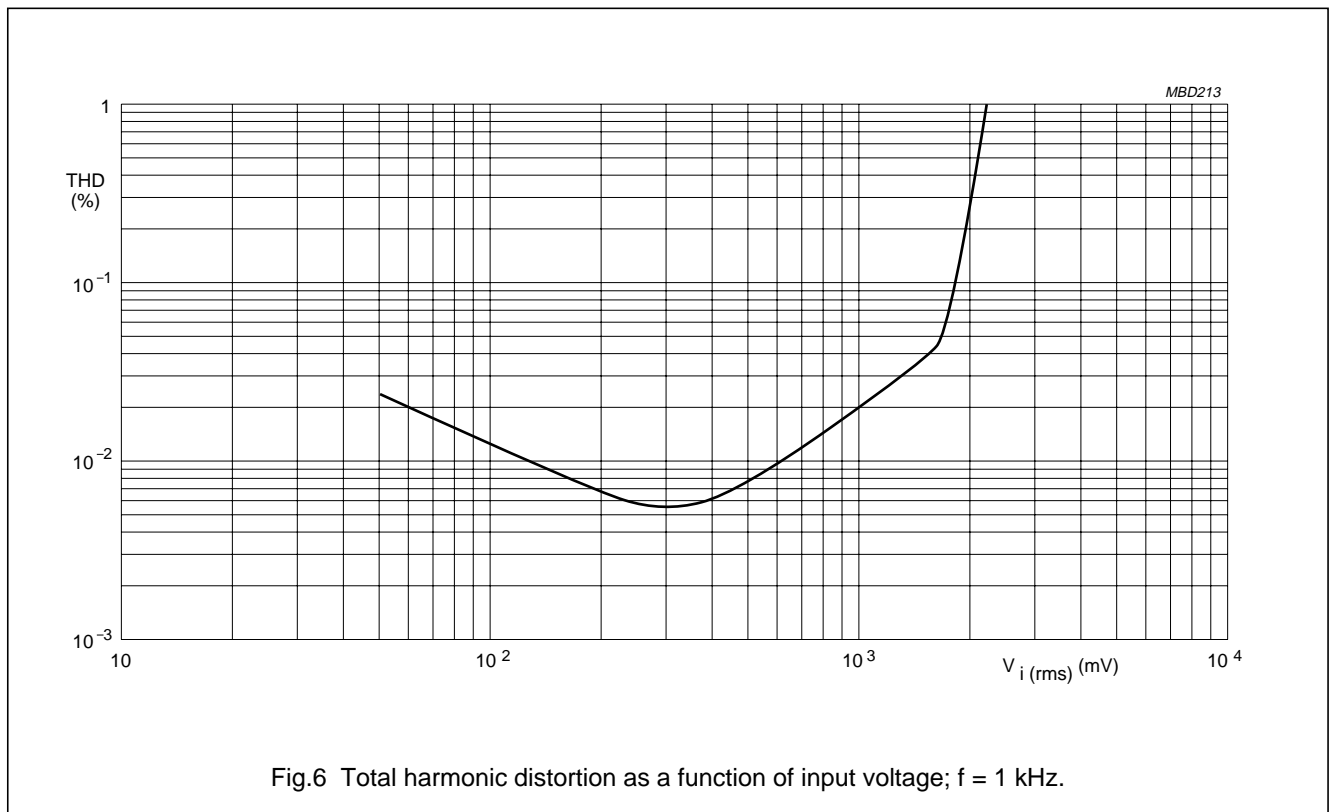
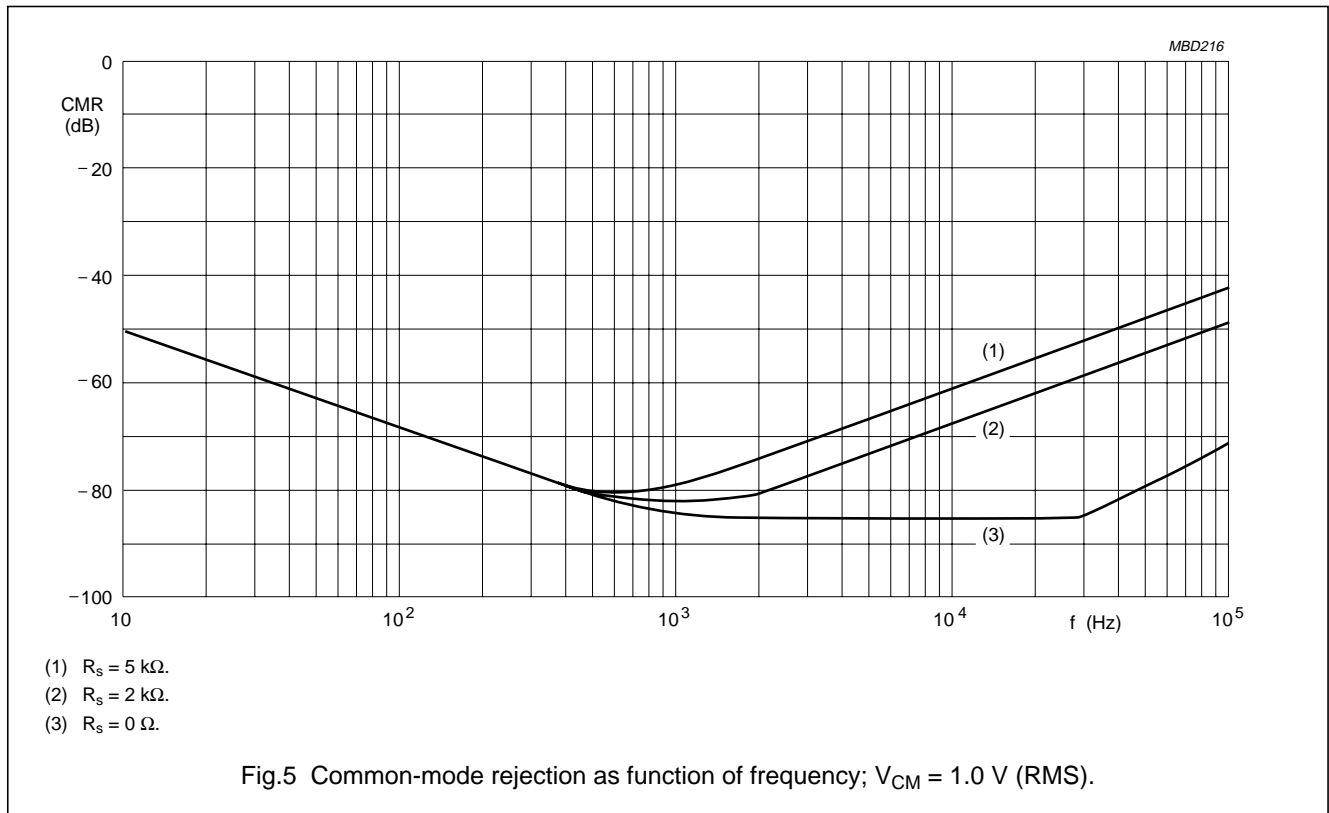

Fig.4 Total harmonic distortion as a function of frequency;  $V_i = 1.0$  V (RMS).

Dual common-mode rejection differential line receiver

TDA8578



Dual common-mode rejection differential line receiver

TDA8578

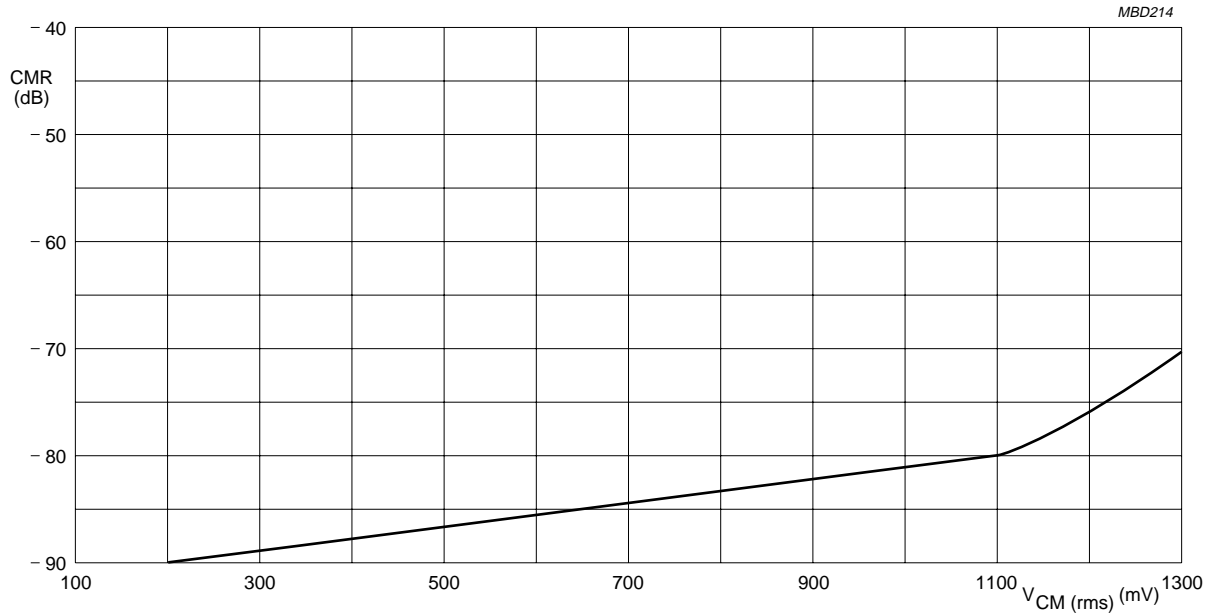
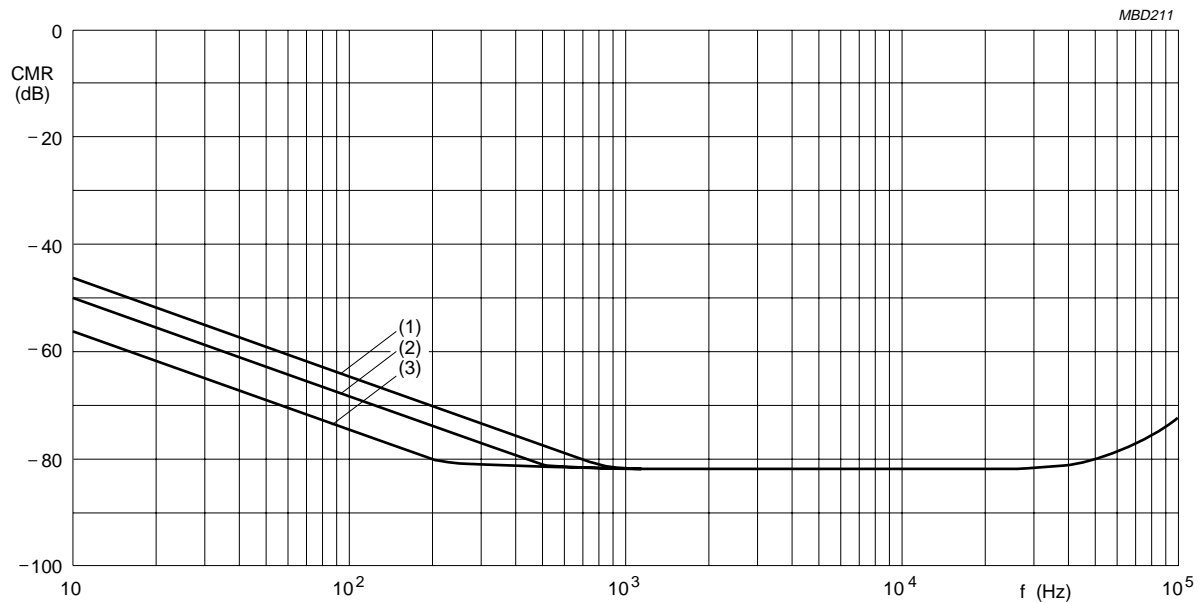

Fig.7 Common-mode rejection as a function of common-mode input voltage;  $f = 1$  kHz;  $R_s = 0 \Omega$ .



- (1)  $C_2 = 22 \mu\text{F}$ .
- (2)  $C_2 = 47 \mu\text{F}$ .
- (3)  $C_2 = 100 \mu\text{F}$ .

Fig.8 Common-mode rejection as a function of frequency;  $V_{CM} = 1.0$  V.



# Dual common-mode rejection differential line receiver

TDA8578

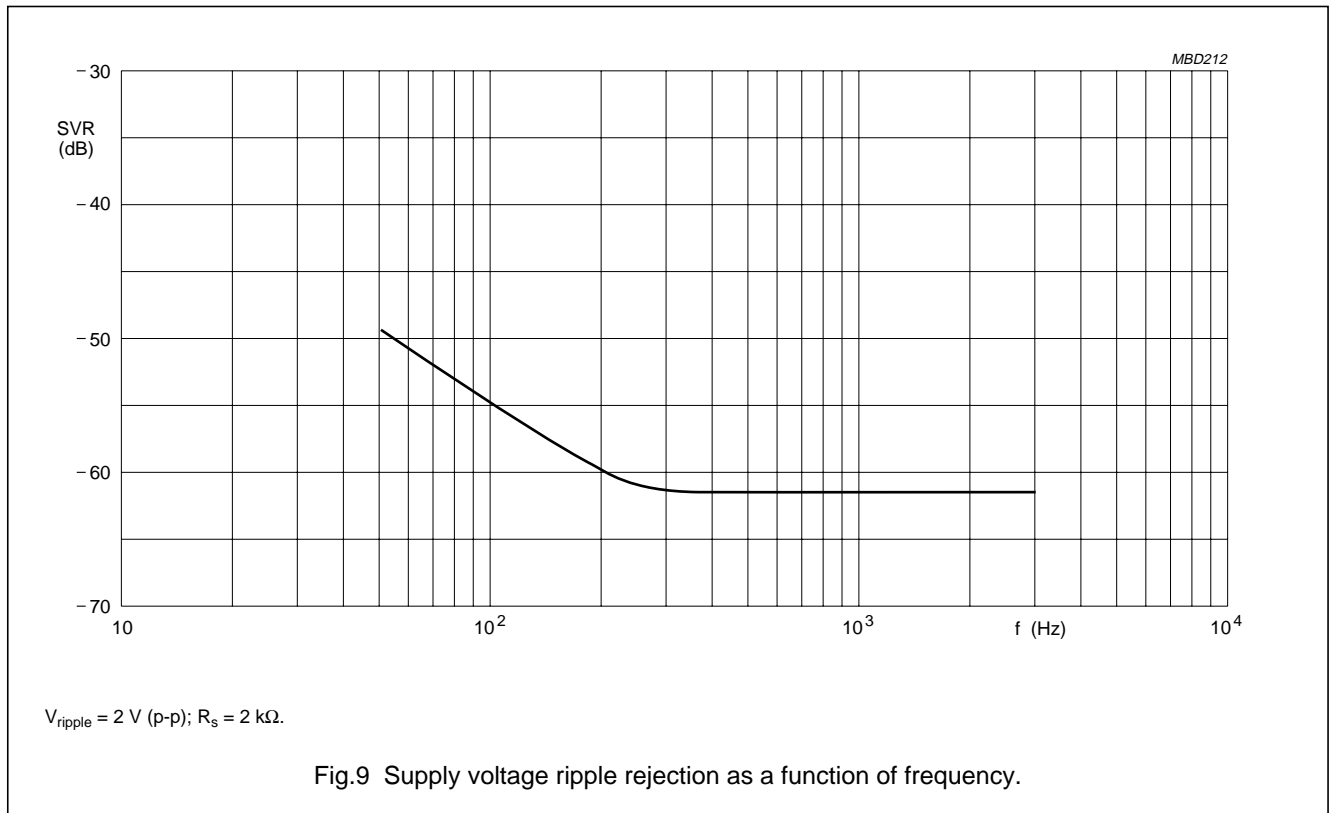

## APPLICATION INFORMATION

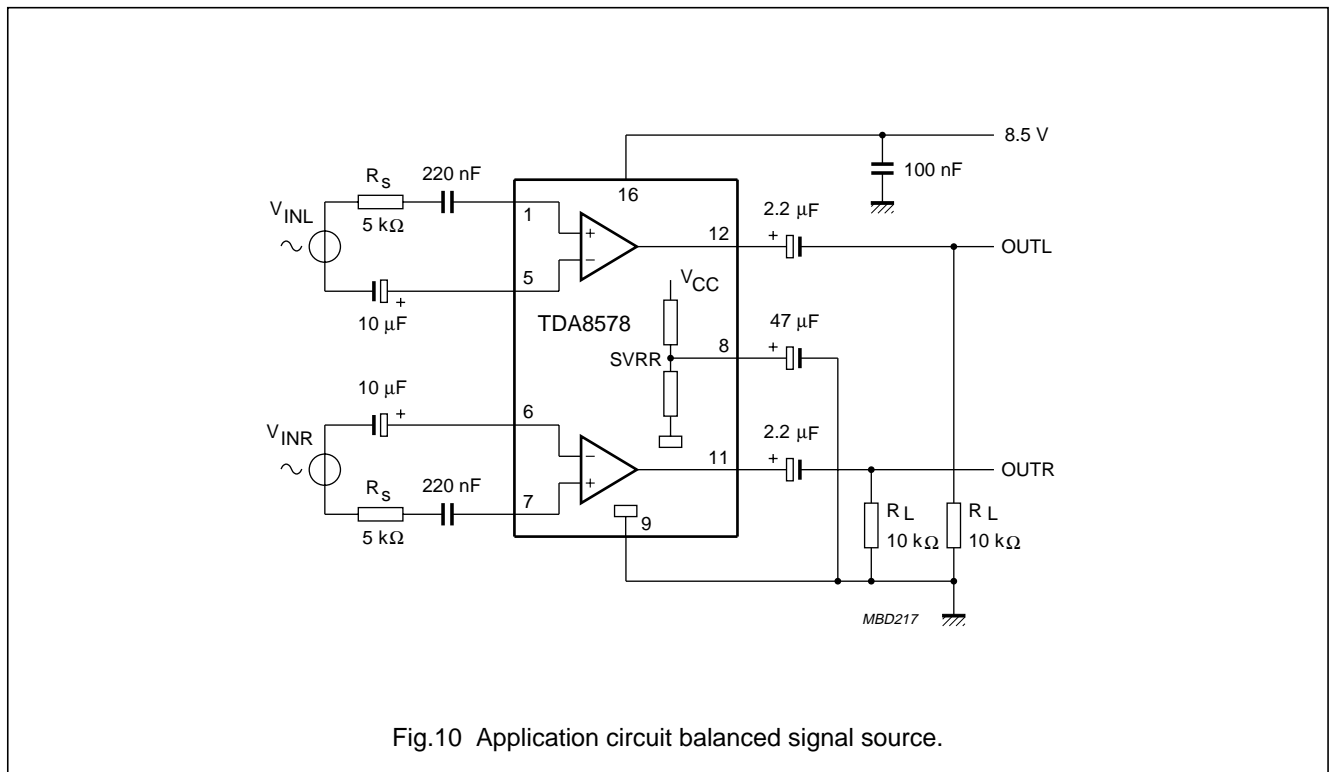

# Dual common-mode rejection differential line receiver

TDA8578

## PACKAGE OUTLINES

DIP16: plastic dual in-line package; 16 leads (300 mil); long body

SOT38-1

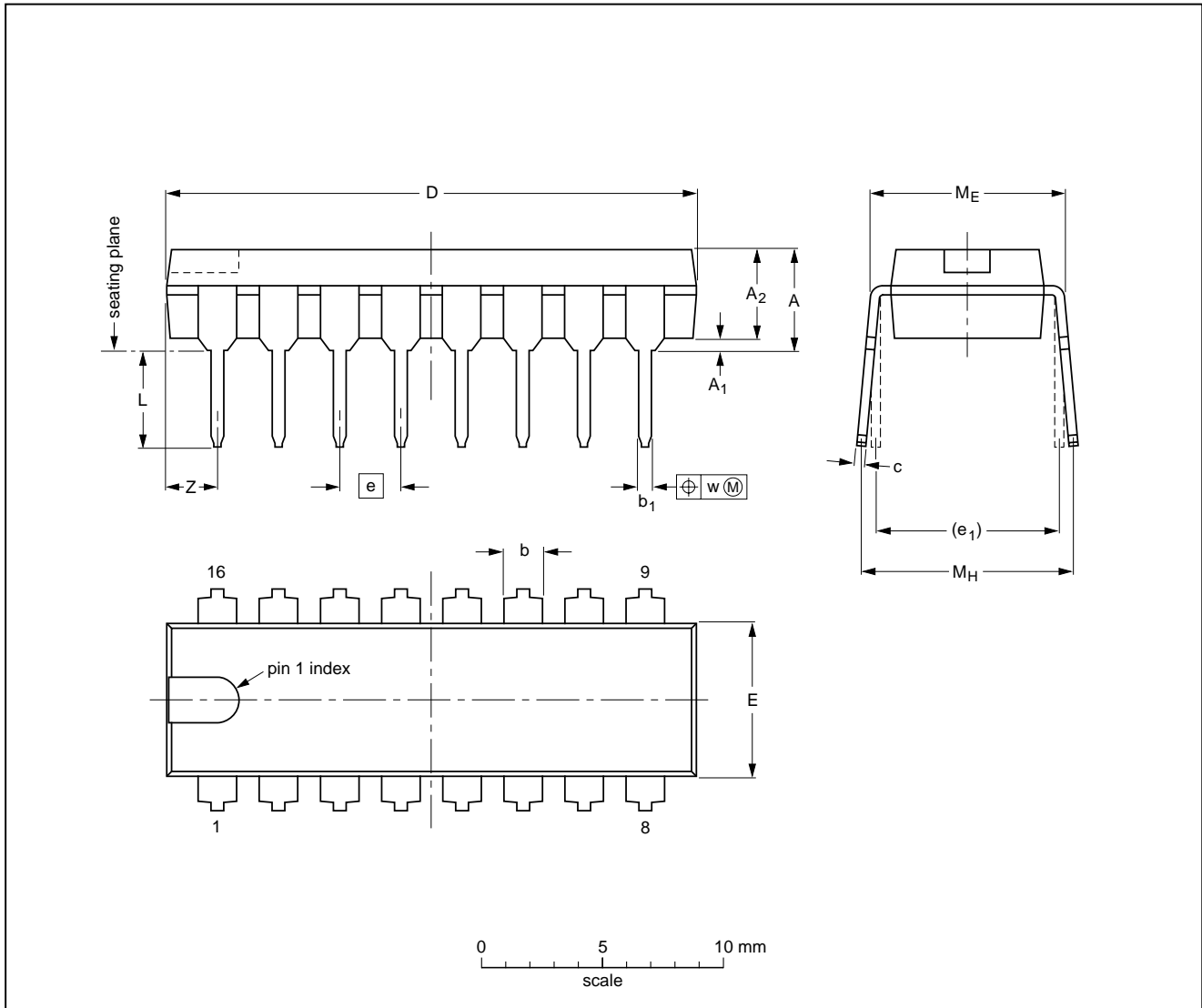

**DIMENSIONS (inch dimensions are derived from the original mm dimensions)**

UNIT	A max.	A <sub>1</sub> min.	A <sub>2</sub> max.	b	b <sub>1</sub>	c	D <sup>(1)</sup>	E <sup>(1)</sup>	e	e <sub>1</sub>	L	M <sub>E</sub>	M <sub>H</sub>	w	Z <sup>(1)</sup> max.
mm	4.7	0.51	3.7	1.40 1.14	0.53 0.38	0.32 0.23	21.8 21.4	6.48 6.20	2.54	7.62	3.9 3.4	8.25 7.80	9.5 8.3	0.254	2.2
inches	0.19	0.020	0.15	0.055 0.045	0.021 0.015	0.013 0.009	0.86 0.84	0.26 0.24	0.10	0.30	0.15 0.13	0.32 0.31	0.37 0.33	0.01	0.087

**Note**

1. Plastic or metal protrusions of 0.25 mm maximum per side are not included.

OUTLINE VERSION	REFERENCES				EUROPEAN PROJECTION	ISSUE DATE
	IEC	JEDEC	EIAJ			
SOT38-1	050G09	MO-001AE				92-10-02 95-01-19

# Dual common-mode rejection differential line receiver

TDA8578

SO16: plastic small outline package; 16 leads; body width 3.9 mm

SOT109-1

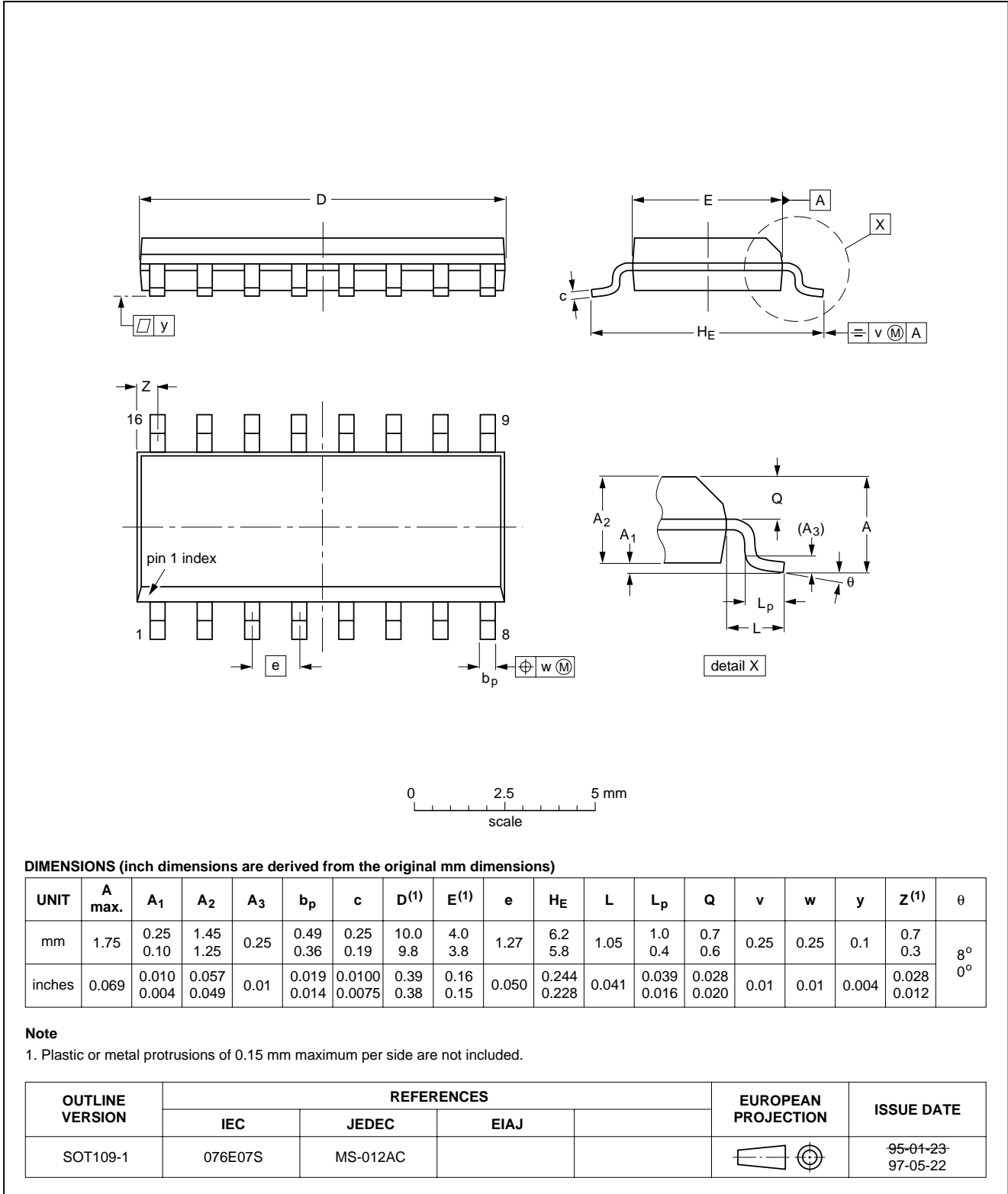

## Dual common-mode rejection differential line receiver

TDA8578

### SOLDERING

#### Introduction

There is no soldering method that is ideal for all IC packages. Wave soldering is often preferred when through-hole and surface mounted components are mixed on one printed-circuit board. However, wave soldering is not always suitable for surface mounted ICs, or for printed-circuits with high population densities. In these situations reflow soldering is often used.

This text gives a very brief insight to a complex technology. A more in-depth account of soldering ICs can be found in our "IC Package Databook" (order code 9398 652 90011).

#### DIP

##### SOLDERING BY DIPPING OR BY WAVE

The maximum permissible temperature of the solder is 260 °C; solder at this temperature must not be in contact with the joint for more than 5 seconds. The total contact time of successive solder waves must not exceed 5 seconds.

The device may be mounted up to the seating plane, but the temperature of the plastic body must not exceed the specified maximum storage temperature ( $T_{stg\ max}$ ). If the printed-circuit board has been pre-heated, forced cooling may be necessary immediately after soldering to keep the temperature within the permissible limit.

##### REPAIRING SOLDERED JOINTS

Apply a low voltage soldering iron (less than 24 V) to the lead(s) of the package, below the seating plane or not more than 2 mm above it. If the temperature of the soldering iron bit is less than 300 °C it may remain in contact for up to 10 seconds. If the bit temperature is between 300 and 400 °C, contact may be up to 5 seconds.

#### SO

##### REFLOW SOLDERING

Reflow soldering techniques are suitable for all SO packages.

Reflow soldering requires solder paste (a suspension of fine solder particles, flux and binding agent) to be applied to the printed-circuit board by screen printing, stencilling or pressure-syringe dispensing before package placement.

Several techniques exist for reflowing; for example, thermal conduction by heated belt. Dwell times vary between 50 and 300 seconds depending on heating method. Typical reflow temperatures range from 215 to 250 °C.

Preheating is necessary to dry the paste and evaporate the binding agent. Preheating duration: 45 minutes at 45 °C.

##### WAVE SOLDERING

Wave soldering techniques can be used for all SO packages if the following conditions are observed:

- A double-wave (a turbulent wave with high upward pressure followed by a smooth laminar wave) soldering technique should be used.
- The longitudinal axis of the package footprint must be parallel to the solder flow.
- The package footprint must incorporate solder thieves at the downstream end.

During placement and before soldering, the package must be fixed with a droplet of adhesive. The adhesive can be applied by screen printing, pin transfer or syringe dispensing. The package can be soldered after the adhesive is cured.

Maximum permissible solder temperature is 260 °C, and maximum duration of package immersion in solder is 10 seconds, if cooled to less than 150 °C within 6 seconds. Typical dwell time is 4 seconds at 250 °C.

A mildly-activated flux will eliminate the need for removal of corrosive residues in most applications.

##### REPAIRING SOLDERED JOINTS

Fix the component by first soldering two diagonally-opposite end leads. Use only a low voltage soldering iron (less than 24 V) applied to the flat part of the lead. Contact time must be limited to 10 seconds at up to 300 °C. When using a dedicated tool, all other leads can be soldered in one operation within 2 to 5 seconds between 270 and 320 °C.

# Dual common-mode rejection differential line receiver

TDA8578

## DEFINITIONS

<b>Data sheet status</b>	
Objective specification	This data sheet contains target or goal specifications for product development.
Preliminary specification	This data sheet contains preliminary data; supplementary data may be published later.
Product specification	This data sheet contains final product specifications.
<b>Limiting values</b>	
Limiting values given are in accordance with the Absolute Maximum Rating System (IEC 134). Stress above one or more of the limiting values may cause permanent damage to the device. These are stress ratings only and operation of the device at these or at any other conditions above those given in the Characteristics sections of the specification is not implied. Exposure to limiting values for extended periods may affect device reliability.	
<b>Application information</b>	
Where application information is given, it is advisory and does not form part of the specification.	

## LIFE SUPPORT APPLICATIONS

These products are not designed for use in life support appliances, devices, or systems where malfunction of these products can reasonably be expected to result in personal injury. Philips customers using or selling these products for use in such applications do so at their own risk and agree to fully indemnify Philips for any damages resulting from such improper use or sale.