

DATA SHEET

TDA8567Q

4 × 25 W BTL quad car radio power amplifier

Product specification
Supersedes data of 1997 Feb 12
File under Integrated Circuits, IC01

1998 Sep 23

4 × 25 W BTL quad car radio power amplifier

TDA8567Q

FEATURES

- Requires very few external components
- High output power
- Low output offset voltage
- Fixed gain
- Diagnostic facility (distortion, short-circuit and temperature pre-warning)
- Good ripple rejection
- Mode select switch (operating, mute and standby)
- Load dump protection
- Short-circuit safe to ground and to V_P and across the load
- Low power dissipation in any short-circuit condition
- Thermally protected
- Reverse polarity safe
- Electrostatic discharge protection
- No switch-on/switch-off plop
- Flexible leads
- Low thermal resistance
- Pin compatible with the TDA8568Q, except for the gain.

GENERAL DESCRIPTION

The TDA8567Q is an integrated class-B output amplifier in a 23-lead Single-In-Line (SIL) plastic power package. It contains four amplifiers in BTL configuration, each with a gain of 26 dB. The output power is 4 × 25 W in a 4 Ω load.

APPLICATIONS

- The device is primarily developed for car radio applications.

QUICK REFERENCE DATA

| SYMBOL | PARAMETER | CONDITIONS | MIN. | TYP. | MAX. | UNIT |
|----------------|---------------------------------|----------------------------|------|------|------|------|
| V_P | operating supply voltage | | 6 | 14.4 | 18 | V |
| I_{ORM} | repetitive peak output current | | – | – | 7.5 | A |
| $I_{q(tot)}$ | total quiescent current | | – | 230 | – | mA |
| I_{stb} | standby current | | – | 0.2 | 100 | μA |
| I_{sw} | switch-on current | | – | – | 80 | μA |
| $ Z_i $ | input impedance | | 25 | 30 | – | kΩ |
| P_o | output power | THD = 10% | – | 25 | – | W |
| SVRR | supply voltage ripple rejection | $R_s = 0 \Omega$ | – | 60 | – | dB |
| α_{cs} | channel separation | $R_s = 10 \text{ k}\Omega$ | – | 50 | – | dB |
| G_v | closed loop voltage gain | | 25 | 26 | 27 | dB |
| $V_{n(o)}$ | noise output voltage | $R_s = 0 \Omega$ | – | – | 120 | μV |
| $ \Delta V_O $ | DC output offset voltage | | – | – | 150 | mV |

ORDERING INFORMATION

| TYPE NUMBER | PACKAGE | | |
|-------------|---------|--|----------|
| | NAME | DESCRIPTION | VERSION |
| TDA8567Q | DBS23P | plastic DIL-bent-SIL power package; 23 leads (straight lead length 3.2 mm) | SOT411-1 |

4 × 25 W BTL quad car radio power amplifier

TDA8567Q

BLOCK DIAGRAM

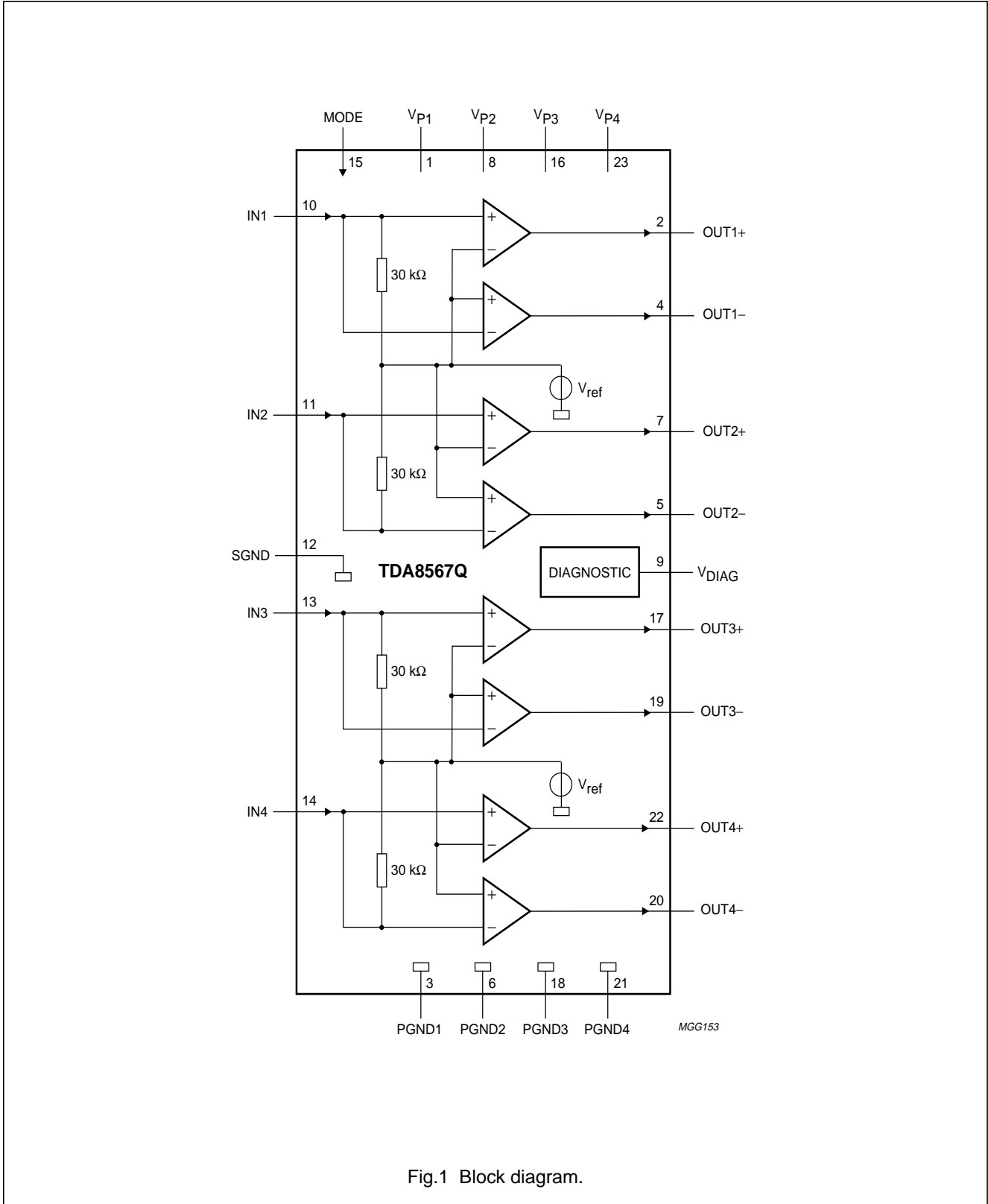

Fig.1 Block diagram.

4 × 25 W BTL quad car radio power amplifier

TDA8567Q

PINNING

| SYMBOL | PIN | DESCRIPTION |
|-------------------|-----|--------------------------|
| V _{P1} | 1 | supply voltage 1 |
| OUT1+ | 2 | output 1+ |
| PGND1 | 3 | power ground 1 |
| OUT1- | 4 | output 1- |
| OUT2- | 5 | output 2- |
| PGND2 | 6 | power ground 2 |
| OUT2+ | 7 | output 2+ |
| V _{P2} | 8 | supply voltage 2 |
| V _{DIAG} | 9 | diagnostic output |
| IN1 | 10 | input 1 |
| IN2 | 11 | input 2 |
| SGND | 12 | signal ground |
| IN3 | 13 | input 3 |
| IN4 | 14 | input 4 |
| MODE | 15 | mode select switch input |
| V _{P3} | 16 | supply voltage 3 |
| OUT3+ | 17 | output 3+ |
| PGND3 | 18 | power ground 3 |
| OUT3- | 19 | output 3- |
| PGND4 | 21 | power ground 4 |
| OUT4+ | 22 | output 4+ |
| V _{P4} | 23 | supply voltage 4 |

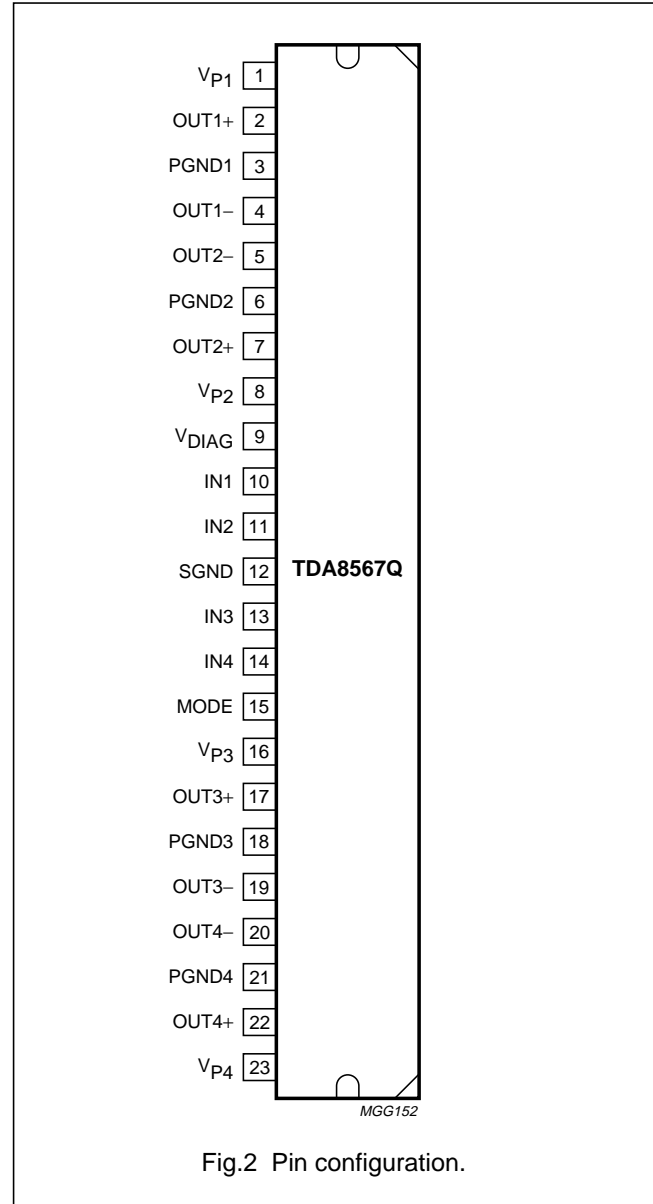

Fig.2 Pin configuration.

4 × 25 W BTL quad car radio power amplifier

TDA8567Q

FUNCTIONAL DESCRIPTION

The TDA8567Q contains four identical amplifiers which can be used for bridge applications. The gain of each amplifier is fixed at 26 dB.

Mode select switch (pin 15)

- Standby: low supply current (<100 μ A)
- Mute: input signal suppressed
- Operating: normal on condition.

Since this pin has a low input current (<80 μ A), a low cost supply switch can be applied.

To avoid switch-on plops, it is advised to keep the amplifier in the mute mode during ≥ 150 ms (charging of the input capacitors at pins 10, 11, 13 and 14). When switching from standby to mute, the slope should be at least 18 V/s.

This can be realized by:

- Microprocessor control
- External timing circuit (see Fig.3).

Diagnostic output (pin 9)

DYNAMIC DISTORTION DETECTOR (DDD)

At the onset of clipping of one or more output stages, the dynamic distortion detector becomes active and pin 9 goes LOW. This information can be used to drive a sound processor or DC volume control to attenuate the input signal and so limit the distortion. The output level of pin 9 is independent of the number of channels that are clipping (see Fig.4).

SHORT-CIRCUIT DIAGNOSTIC

When a short-circuit occurs at one or more outputs to ground or to the supply voltage, the output stages are switched off until the short-circuit is removed and the device is switched on again, with a delay of approximately 10 ms after removal of the short-circuit. During this short-circuit condition, pin 9 is continuously LOW.

When a short-circuit occurs across the load of one or more channels, the output stages are switched off during approximately 10 ms. After that time it is checked during approximately 50 μ s to determine whether the short-circuit is still present.

Due to this duty cycle of 50 μ s/10 ms the average current consumption during this short-circuit condition is very low.

During this short-circuit condition, pin 9 is LOW for 10 ms and HIGH for 50 μ s (see Fig.5). The protection circuits of all channels are coupled. This means that if a short-circuit condition occurs in **one** of the channels, **all** channels are switched off. Consequently, the power dissipation in any short-circuit condition is very low.

TEMPERATURE PRE-WARNING

When the virtual junction temperature T_{vj} reaches 145 $^{\circ}$ C, pin 9 goes LOW.

OPEN COLLECTOR OUTPUTS

The diagnostic pin has an open collector output, so more devices can be tied together. An external pull-up resistor is needed.

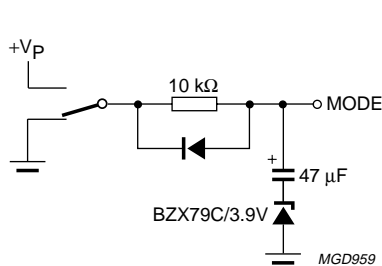

Fig.3 Mode select switch circuitry.

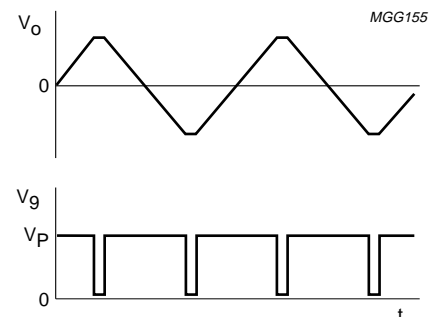

Fig.4 Distortion detector waveform.

4 × 25 W BTL quad car radio power amplifier

TDA8567Q

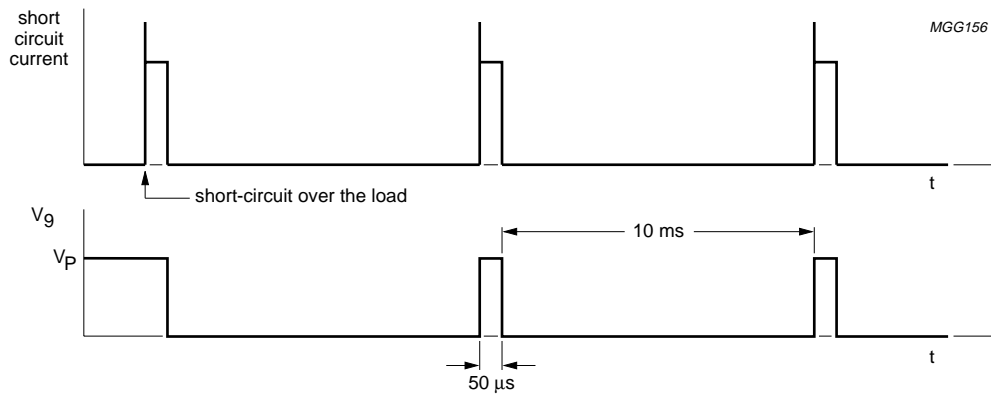

Fig.5 Short-circuit waveform.

4 × 25 W BTL quad car radio power amplifier

TDA8567Q

LIMITING VALUES

In accordance with the Absolute Maximum Rating System (IEC 134).

| SYMBOL | PARAMETER | CONDITIONS | MIN. | MAX. | UNIT |
|-----------------------|------------------------------------|--|------|------|------|
| V _P | supply voltage | operating | – | 18 | V |
| | | non-operating | – | 30 | V |
| | | load dump protection; during 50 ms; t _r ≥ 2.5 ms | – | 45 | V |
| V _{sc(safe)} | short-circuit safe voltage | | – | 18 | V |
| V _{rp} | reverse polarity voltage | | – | 6 | V |
| I _{OSM} | non-repetitive peak output current | | – | 10 | A |
| I _{ORM} | repetitive peak output current | | – | 7.5 | A |
| P _{tot} | total power dissipation | | – | 60 | W |
| T _{stg} | storage temperature | | –55 | +150 | °C |
| T _{amb} | operating ambient temperature | | –40 | +85 | °C |
| T _{vj} | virtual junction temperature | | – | 150 | °C |

THERMAL CHARACTERISTICS

| SYMBOL | PARAMETER | VALUE | UNIT |
|---------------------|---|-------|------|
| R _{th j-a} | thermal resistance from junction to ambient in free air | 40 | K/W |
| R _{th j-c} | thermal resistance from junction to case (see Fig.6) | 1 | K/W |

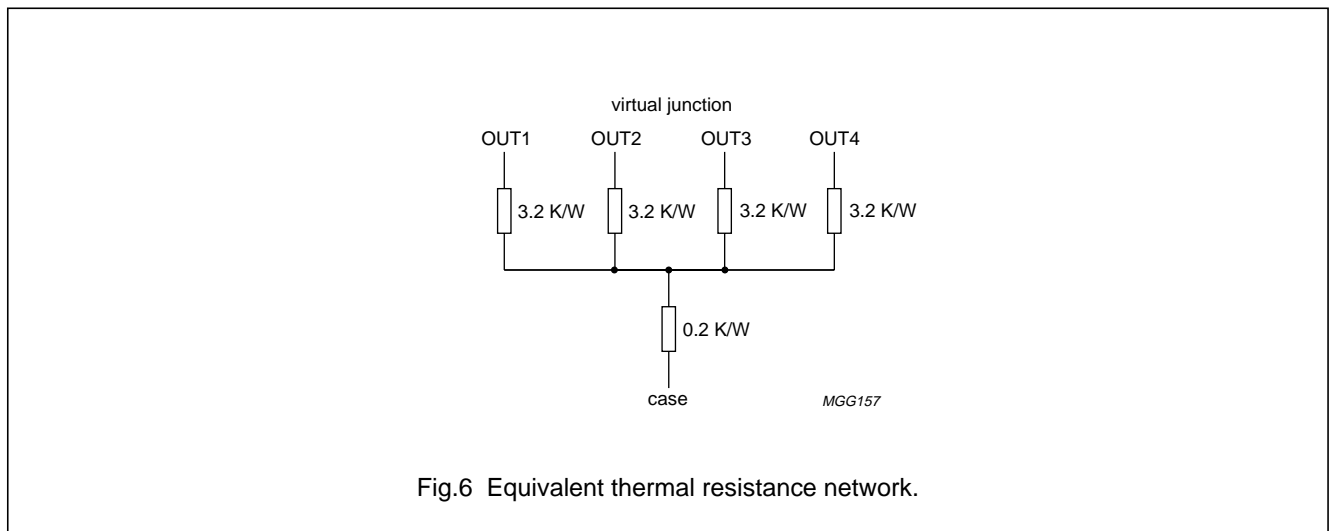

Fig.6 Equivalent thermal resistance network.

QUALITY SPECIFICATION

In accordance with "SNW-FQ-611E". The number of the quality specification can be found in the "Quality Reference Handbook". The handbook can be ordered using the code 9397 750 00192.

4 × 25 W BTL quad car radio power amplifier

TDA8567Q

DC CHARACTERISTICS

$V_P = 14.4$ V; $T_{amb} = 25$ °C; measured in Fig.7; unless otherwise specified.

| SYMBOL | PARAMETER | CONDITIONS | MIN. | TYP. | MAX. | UNIT |
|----------------------------|----------------------------|----------------------------|------|------|-------|------|
| Supply | | | | | | |
| V_P | supply voltage | note 1 | 6 | 14.4 | 18 | V |
| $I_{q(tot)}$ | total quiescent current | $R_L = \infty$ | – | 230 | 360 | mA |
| Operating condition | | | | | | |
| V_{15} | mode select switch level | | 8.5 | – | V_P | V |
| I_{15} | mode select switch current | $V_{15} = 14.4$ V | – | 30 | 80 | μA |
| V_O | output voltage | note 2 | – | 7.0 | – | V |
| $ \Delta V_O $ | output offset voltage | | – | – | 150 | mV |
| Mute condition | | | | | | |
| V_{15} | mode select switch level | | 3.3 | – | 6.4 | V |
| V_O | output voltage | note 2 | – | 7.0 | – | V |
| $ \Delta V_O $ | output offset voltage | | – | – | 150 | mV |
| Standby condition | | | | | | |
| V_{15} | mode select switch level | | 0 | – | 2 | V |
| I_{stb} | standby current | | – | 0.2 | 100 | μA |
| Diagnostic | | | | | | |
| V_9 | diagnostic output voltage | during any fault condition | – | – | 0.6 | V |
| T_{vj} | temperature pre-warning | $V_9 = 0.6$ V | – | 145 | – | °C |

Notes

1. The circuit is DC adjusted at $V_P = 6$ to 18 V and AC operating at $V_P = 8.5$ to 18 V.
2. At 18 V < V_P < 30 V the DC output voltage $\leq \frac{1}{2}V_P$.

4 × 25 W BTL quad car radio power amplifier

TDA8567Q

AC CHARACTERISTICS

$V_P = 14.4\text{ V}$; $R_L = 4\ \Omega$; $f = 1\text{ kHz}$; $T_{\text{amb}} = 25\text{ °C}$; measured in Fig.7; unless otherwise specified.

| SYMBOL | PARAMETER | CONDITIONS | MIN. | TYP. | MAX. | UNIT |
|----------------|---------------------------------|---|------|-------------|------|---------------|
| P_o | output power | THD = 0.5% | 16 | 19 | – | W |
| | | THD = 10% | 21 | 25 | – | W |
| | | THD = 30% | 28 | 35 | – | W |
| | | $V_P = 13.2\text{ V}$; THD = 0.5% | – | 15 | – | W |
| | | $V_P = 13.2\text{ V}$; THD = 10% | – | 21 | – | W |
| THD | total harmonic distortion | $P_o = 1\text{ W}$ | – | 0.05 | – | % |
| | | $V_g \leq 0.6\text{ V}$; note 8 | – | 10 | – | % |
| B_p | power bandwidth | THD = 0.5%; $P_o = -1\text{ dB}$ with respect to 16 W | – | 20 to 20000 | – | Hz |
| $f_{ro(l)}$ | low frequency roll-off | at -1 dB ; note 1 | – | 25 | – | Hz |
| $f_{ro(h)}$ | high frequency roll-off | at -1 dB | 20 | – | – | kHz |
| G_v | closed loop voltage gain | | 25 | 26 | 27 | dB |
| SVRR | supply voltage ripple rejection | on; note 2 | 50 | – | – | dB |
| | | mute; note 2 | 50 | – | – | dB |
| | | standby; note 2 | 80 | – | – | dB |
| $ Z_i $ | input impedance | | 25 | 30 | 38 | k Ω |
| $V_{n(o)}$ | noise output voltage | on; note 3 | – | 85 | 120 | μV |
| | | on; note 4 | – | 100 | – | μV |
| | | mute; note 5 | – | 60 | – | μV |
| α_{cs} | channel separation | note 6 | 45 | – | – | dB |
| $ \Delta G_v $ | channel unbalance | | – | – | 1 | dB |
| V_o | output signal in mute | note 7 | – | – | 2 | mV |

Notes

1. Frequency response externally fixed.
2. $V_{\text{ripple}} = V_{\text{ripple(max)}} = 2\text{ V}$ (p-p); $R_s = 0\ \Omega$.
3. $B = 20\text{ Hz}$ to 20 kHz ; $R_s = 0\ \Omega$.
4. $B = 20\text{ Hz}$ to 20 kHz ; $R_s = 10\text{ k}\Omega$.
5. $B = 20\text{ Hz}$ to 20 kHz ; independent of R_s .
6. $P_o = 16\text{ W}$; $R_s = 10\text{ k}\Omega$.
7. $V_i = V_{i(\text{max})} = 1\text{ V}$ (RMS).
8. Dynamic Distortion Detector (DDD) active, pin 9 is set to logic 0.

4 × 25 W BTL quad car radio power amplifier

TDA8567Q

TEST AND APPLICATION INFORMATION

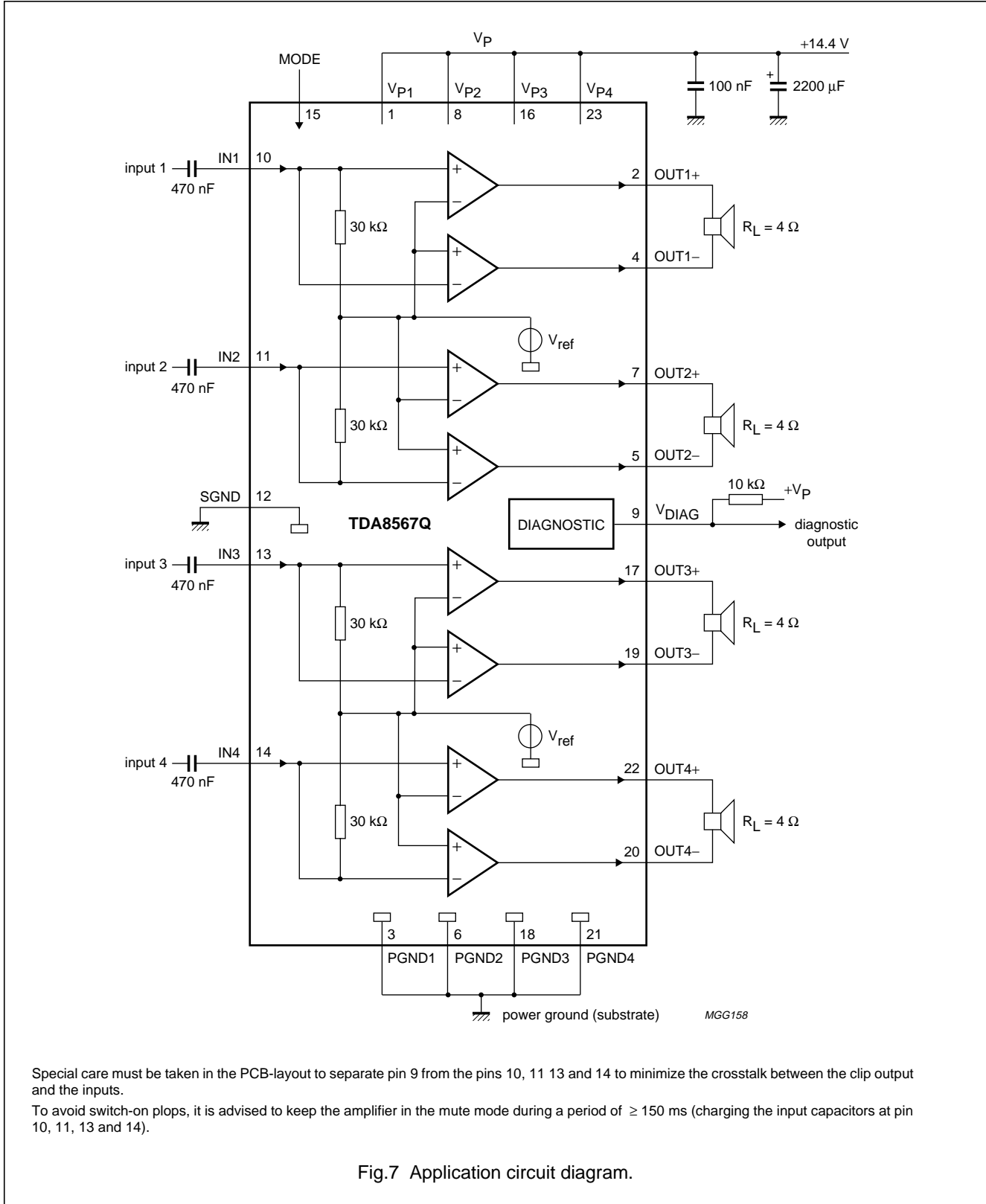

4 × 25 W BTL quad car radio power amplifier

TDA8567Q

Test information

Figures 8 to 13 have the following conditions: $V_P = 14.4\text{ V}$; $R_L = 4\ \Omega$; $f = 1\text{ kHz}$; 80 kHz filter used; unless otherwise specified.

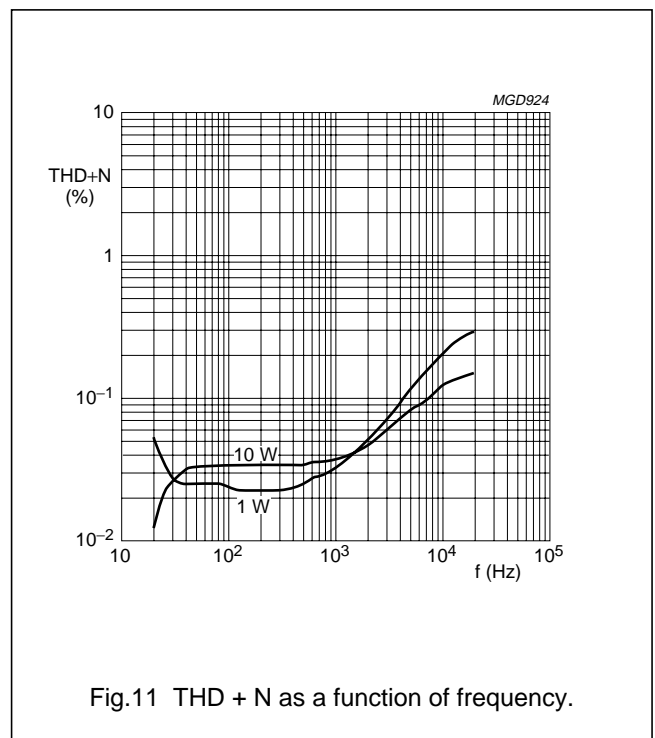
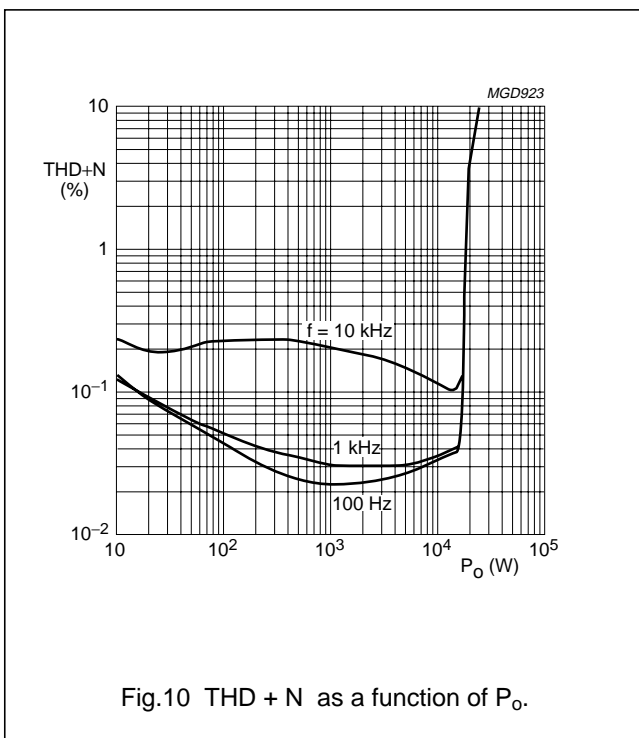
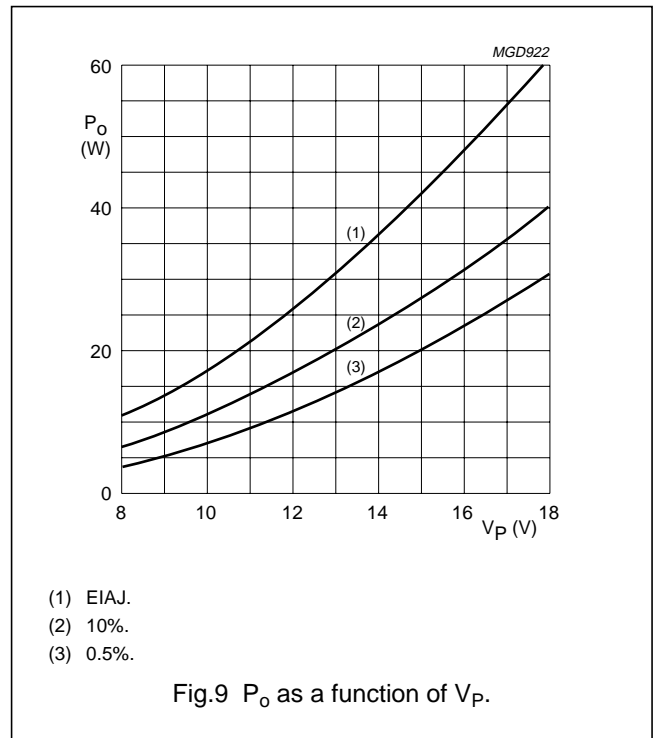
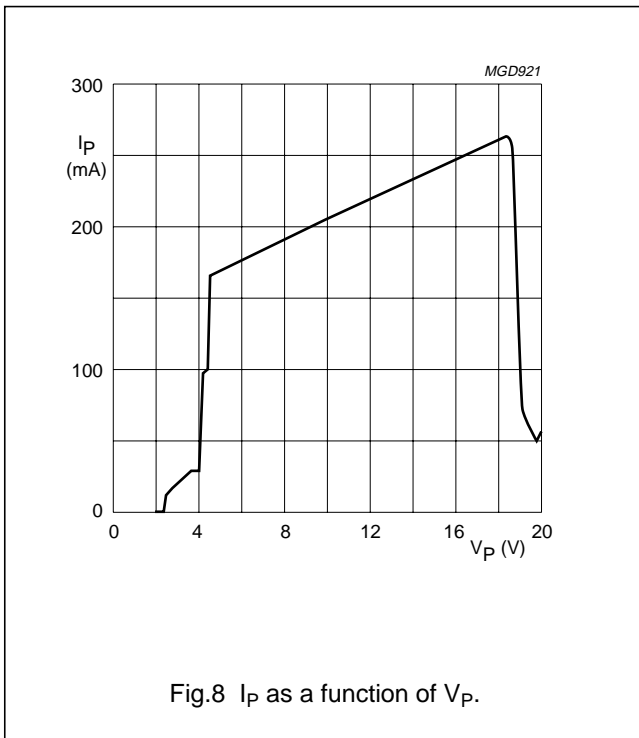

4 × 25 W BTL quad car radio power amplifier

TDA8567Q

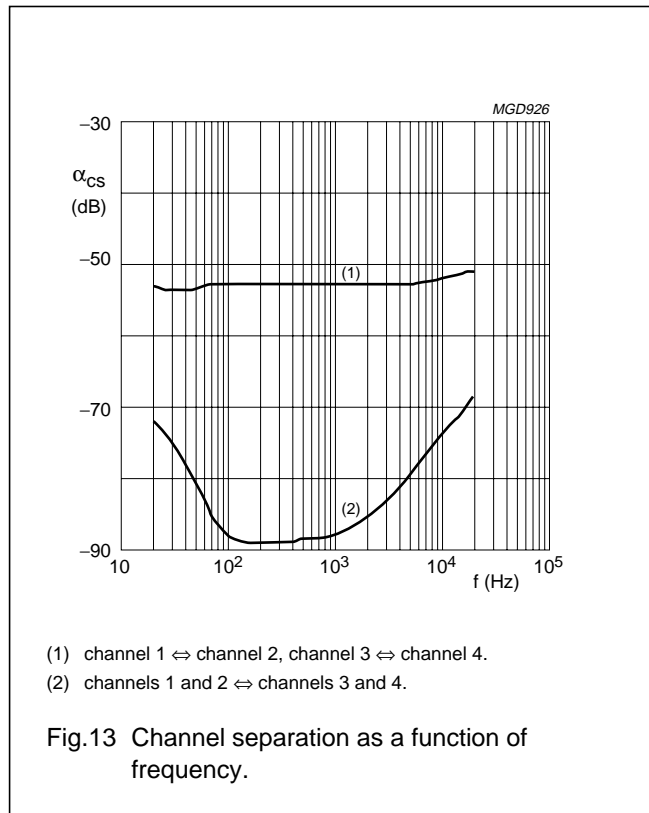
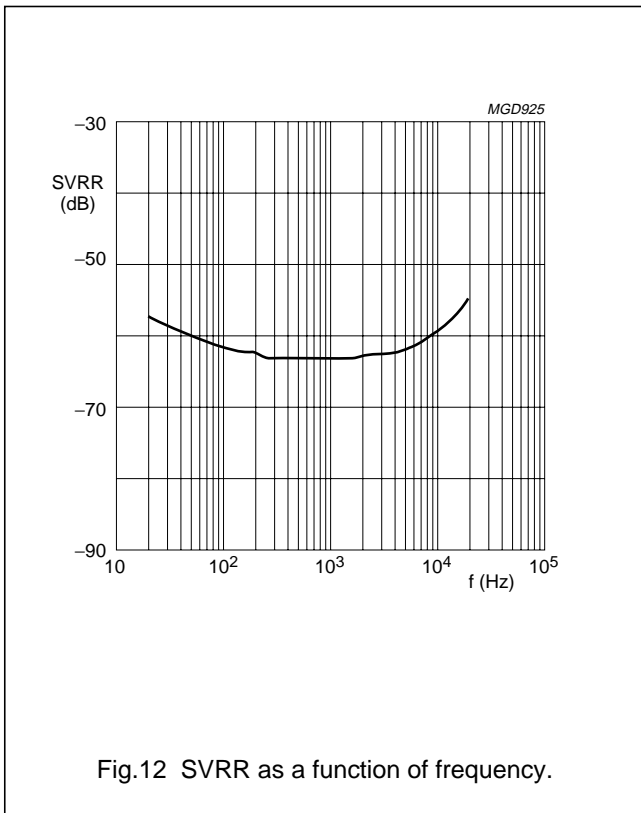

4 × 25 W BTL quad car radio power amplifier

TDA8567Q

PCB layout

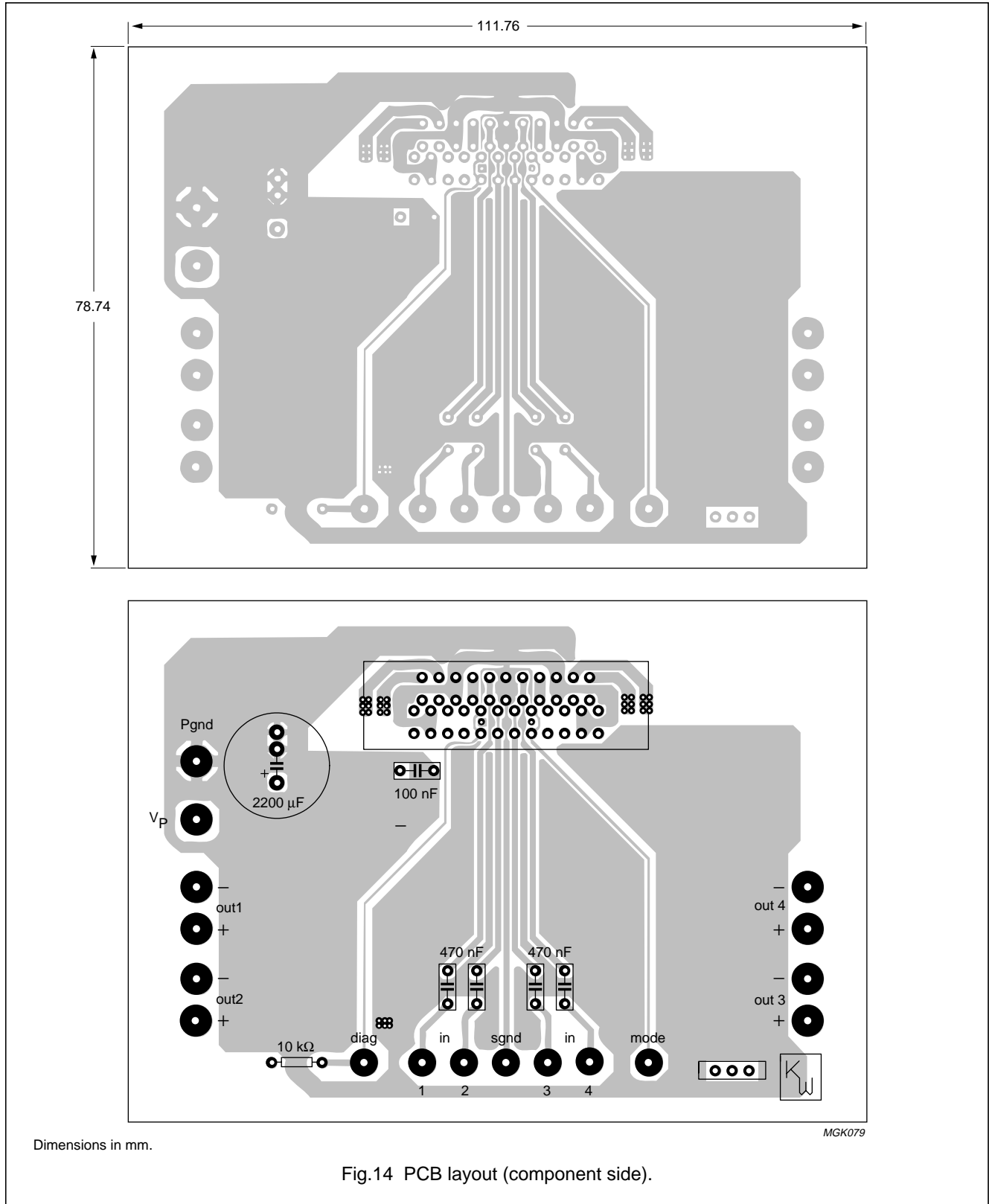

Dimensions in mm.

Fig.14 PCB layout (component side).

4 × 25 W BTL quad car radio power amplifier

TDA8567Q

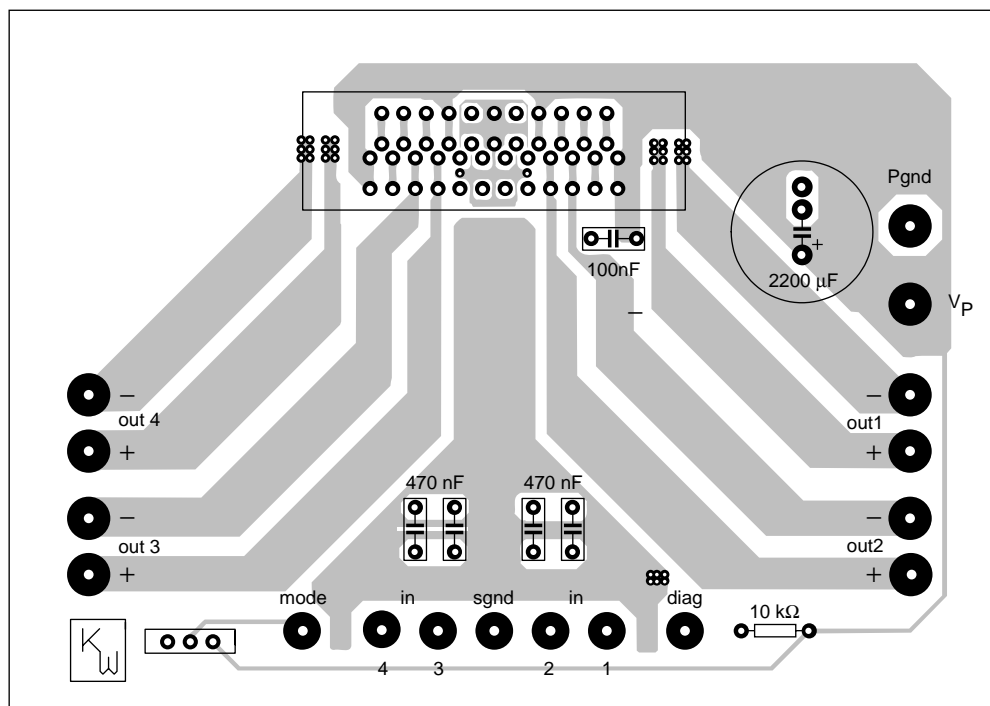
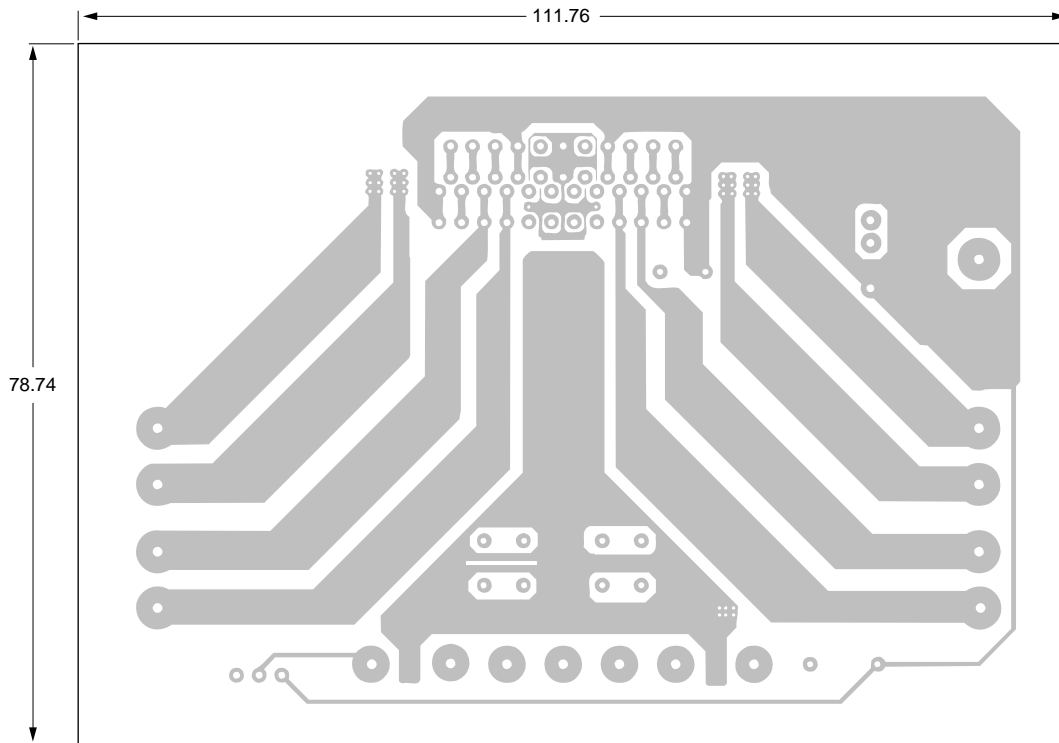

Dimensions in mm.

Fig.15 PCB layout (soldering side).

4 × 25 W BTL quad car radio power amplifier

TDA8567Q

PACKAGE OUTLINE

DBS23P: plastic DIL-bent-SIL power package; 23 leads (straight lead length 3.2 mm)

SOT411-1

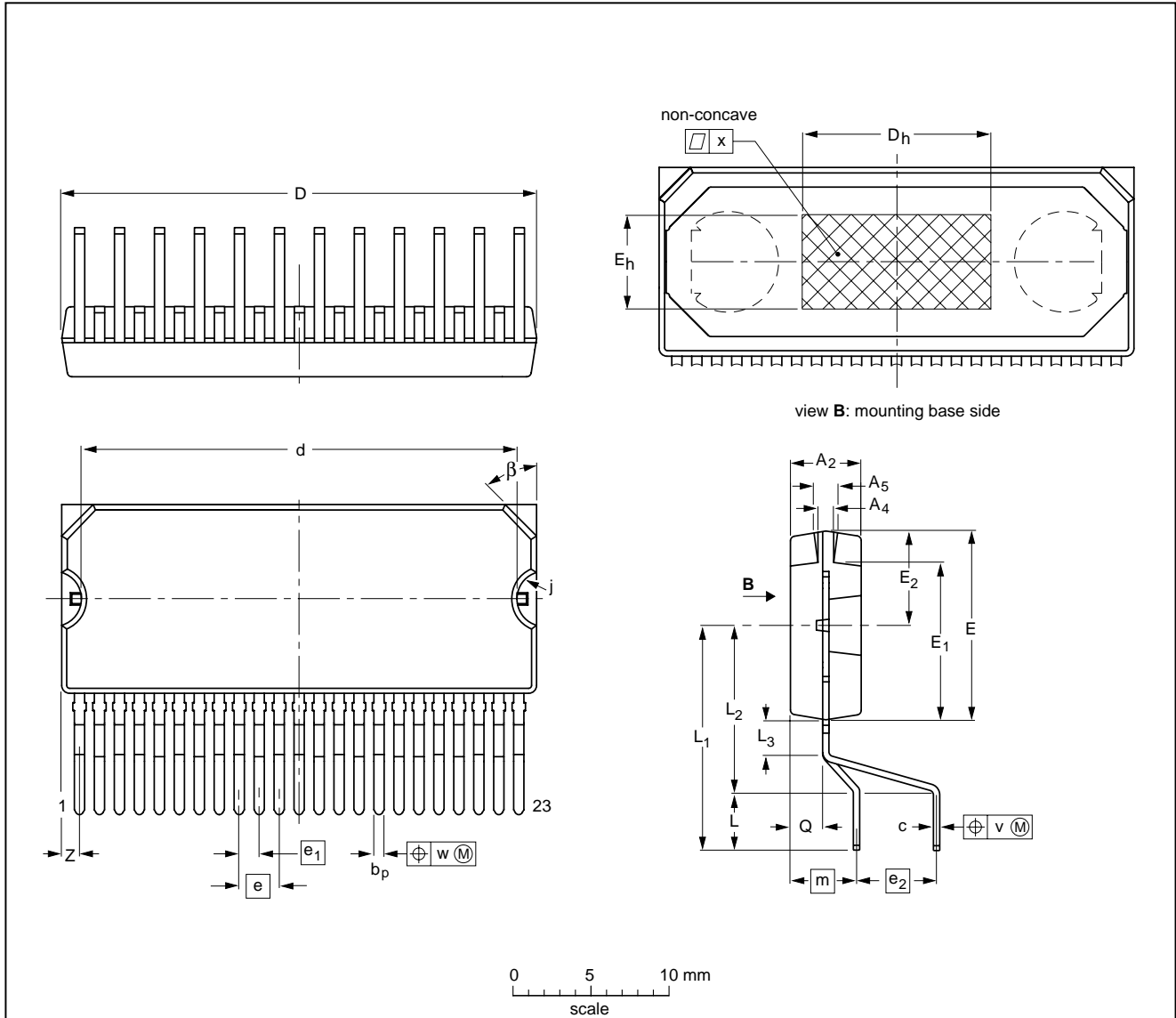

DIMENSIONS (mm are the original dimensions)

| UNIT | A ₂ | A ₄ | A ₅ | b _p | c | D ⁽¹⁾ | d | D _h | E ⁽¹⁾ | e | e ₁ | e ₂ | E _h | E ₁ | E ₂ | j | L | L ₁ | L ₂ | L ₃ | m | Q | v | w | x | β | Z ⁽¹⁾ |
|------|----------------|----------------|----------------|----------------|------|------------------|------|----------------|------------------|------|----------------|----------------|----------------|----------------|----------------|------|-----|----------------|----------------|----------------|-----|-----|-----|------|------|-----|------------------|
| mm | 4.6 | 1.15 | 1.65 | 0.75 | 0.55 | 30.4 | 28.0 | 12 | 12.2 | 2.54 | 1.27 | 5.08 | 6 | 10.15 | 6.2 | 1.85 | 3.6 | 14.0 | 10.7 | 2.4 | 4.3 | 2.1 | 0.6 | 0.25 | 0.03 | 45° | 1.43 |
| | 4.3 | 0.85 | 1.35 | 0.60 | 0.35 | 29.9 | 27.5 | | 11.8 | | | | | 9.85 | 5.8 | 1.65 | 2.8 | 13.0 | 9.9 | 1.6 | | 1.8 | | | | | 0.78 |

Note

1. Plastic or metal protrusions of 0.25 mm maximum per side are not included.

| OUTLINE VERSION | REFERENCES | | | | EUROPEAN PROJECTION | ISSUE DATE |
|-----------------|------------|-------|------|--|---------------------|----------------------|
| | IEC | JEDEC | EIAJ | | | |
| SOT411-1 | | | | | | 96-10-11 98-02-20 |

4 × 25 W BTL quad car radio power amplifier

TDA8567Q

SOLDERING

Introduction

There is no soldering method that is ideal for all IC packages. Wave soldering is often preferred when through-hole and surface mounted components are mixed on one printed-circuit board. However, wave soldering is not always suitable for surface mounted ICs, or for printed-circuits with high population densities. In these situations reflow soldering is often used.

This text gives a very brief insight to a complex technology. A more in-depth account of soldering ICs can be found in our *"Data Handbook IC26; Integrated Circuit Packages"* (order code 9398 652 90011).

Soldering by dipping or by wave

The maximum permissible temperature of the solder is 260 °C; solder at this temperature must not be in contact with the joint for more than 5 seconds. The total contact time of successive solder waves must not exceed 5 seconds.

The device may be mounted up to the seating plane, but the temperature of the plastic body must not exceed the specified maximum storage temperature ($T_{stg\ max}$). If the printed-circuit board has been pre-heated, forced cooling may be necessary immediately after soldering to keep the temperature within the permissible limit.

Repairing soldered joints

Apply a low voltage soldering iron (less than 24 V) to the lead(s) of the package, below the seating plane or not more than 2 mm above it. If the temperature of the soldering iron bit is less than 300 °C it may remain in contact for up to 10 seconds. If the bit temperature is between 300 and 400 °C, contact may be up to 5 seconds.

DEFINITIONS

| Data sheet status | |
|---|---|
| Objective specification | This data sheet contains target or goal specifications for product development. |
| Preliminary specification | This data sheet contains preliminary data; supplementary data may be published later. |
| Product specification | This data sheet contains final product specifications. |
| Limiting values | |
| Limiting values given are in accordance with the Absolute Maximum Rating System (IEC 134). Stress above one or more of the limiting values may cause permanent damage to the device. These are stress ratings only and operation of the device at these or at any other conditions above those given in the Characteristics sections of the specification is not implied. Exposure to limiting values for extended periods may affect device reliability. | |
| Application information | |
| Where application information is given, it is advisory and does not form part of the specification. | |

LIFE SUPPORT APPLICATIONS

These products are not designed for use in life support appliances, devices, or systems where malfunction of these products can reasonably be expected to result in personal injury. Philips customers using or selling these products for use in such applications do so at their own risk and agree to fully indemnify Philips for any damages resulting from such improper use or sale.

4 × 25 W BTL quad car radio power
amplifier

TDA8567Q

NOTES

4 × 25 W BTL quad car radio power
amplifier

TDA8567Q

NOTES

4 × 25 W BTL quad car radio power
amplifier

TDA8567Q

NOTES

Philips Semiconductors – a worldwide company

Argentina: see South America

Australia: 34 Waterloo Road, NORTH RYDE, NSW 2113, Tel. +61 2 9805 4455, Fax. +61 2 9805 4466

Austria: Computerstr. 6, A-1101 WIEN, P.O. Box 213, Tel. +43 160 1010, Fax. +43 160 101 1210

Belarus: Hotel Minsk Business Center, Bld. 3, r. 1211, Volodarski Str. 6, 220050 MINSK, Tel. +375 172 200 733, Fax. +375 172 200 773

Belgium: see The Netherlands

Brazil: see South America

Bulgaria: Philips Bulgaria Ltd., Energoproject, 15th floor, 51 James Bourchier Blvd., 1407 SOFIA, Tel. +359 2 689 211, Fax. +359 2 689 102

Canada: PHILIPS SEMICONDUCTORS/COMPONENTS, Tel. +1 800 234 7381

China/Hong Kong: 501 Hong Kong Industrial Technology Centre, 72 Tat Chee Avenue, Kowloon Tong, HONG KONG, Tel. +852 2319 7888, Fax. +852 2319 7700

Colombia: see South America

Czech Republic: see Austria

Denmark: Prags Boulevard 80, PB 1919, DK-2300 COPENHAGEN S, Tel. +45 32 88 2636, Fax. +45 31 57 0044

Finland: Sinikalliontie 3, FIN-02630 ESPOO, Tel. +358 9 615800, Fax. +358 9 61580920

France: 51 Rue Carnot, BP317, 92156 SURESNES Cedex, Tel. +33 1 40 99 6161, Fax. +33 1 40 99 6427

Germany: Hammerbrookstraße 69, D-20097 HAMBURG, Tel. +49 40 23 53 60, Fax. +49 40 23 536 300

Greece: No. 15, 25th March Street, GR 17778 TAVROS/ATHENS, Tel. +30 1 4894 339/239, Fax. +30 1 4814 240

Hungary: see Austria

India: Philips INDIA Ltd, Band Box Building, 2nd floor, 254-D, Dr. Annie Besant Road, Worli, MUMBAI 400 025, Tel. +91 22 493 8541, Fax. +91 22 493 0966

Indonesia: PT Philips Development Corporation, Semiconductors Division, Gedung Philips, Jl. Buncit Raya Kav.99-100, JAKARTA 12510, Tel. +62 21 794 0040 ext. 2501, Fax. +62 21 794 0080

Ireland: Newstead, Clonskeagh, DUBLIN 14, Tel. +353 1 7640 000, Fax. +353 1 7640 200

Israel: RAPAC Electronics, 7 Kehilat Saloniki St, PO Box 18053, TEL AVIV 61180, Tel. +972 3 645 0444, Fax. +972 3 649 1007

Italy: PHILIPS SEMICONDUCTORS, Piazza IV Novembre 3, 20124 MILANO, Tel. +39 2 6752 2531, Fax. +39 2 6752 2557

Japan: Philips Bldg 13-37, Kohnan 2-chome, Minato-ku, TOKYO 108-8507, Tel. +81 3 3740 5130, Fax. +81 3 3740 5077

Korea: Philips House, 260-199 Itaewon-dong, Yongsan-ku, SEOUL, Tel. +82 2 709 1412, Fax. +82 2 709 1415

Malaysia: No. 76 Jalan Universiti, 46200 PETALING JAYA, SELANGOR, Tel. +60 3 750 5214, Fax. +60 3 757 4880

Mexico: 5900 Gateway East, Suite 200, EL PASO, TEXAS 79905, Tel. +9-5 800 234 7381

Middle East: see Italy

Netherlands: Postbus 90050, 5600 PB EINDHOVEN, Bldg. VB, Tel. +31 40 27 82785, Fax. +31 40 27 88399

New Zealand: 2 Wagener Place, C.P.O. Box 1041, AUCKLAND, Tel. +64 9 849 4160, Fax. +64 9 849 7811

Norway: Box 1, Manglerud 0612, OSLO, Tel. +47 22 74 8000, Fax. +47 22 74 8341

Pakistan: see Singapore

Philippines: Philips Semiconductors Philippines Inc., 106 Valero St. Salcedo Village, P.O. Box 2108 MCC, MAKATI, Metro MANILA, Tel. +63 2 816 6380, Fax. +63 2 817 3474

Poland: Ul. Lukiska 10, PL 04-123 WARSZAWA, Tel. +48 22 612 2831, Fax. +48 22 612 2327

Portugal: see Spain

Romania: see Italy

Russia: Philips Russia, Ul. Usatcheva 35A, 119048 MOSCOW, Tel. +7 095 755 6918, Fax. +7 095 755 6919

Singapore: Lorong 1, Toa Payoh, SINGAPORE 319762, Tel. +65 350 2538, Fax. +65 251 6500

Slovakia: see Austria

Slovenia: see Italy

South Africa: S.A. PHILIPS Pty Ltd., 195-215 Main Road Martindale, 2092 JOHANNESBURG, P.O. Box 7430 Johannesburg 2000, Tel. +27 11 470 5911, Fax. +27 11 470 5494

South America: Al. Vicente Pinzon, 173, 6th floor, 04547-130 SÃO PAULO, SP, Brazil, Tel. +55 11 821 2333, Fax. +55 11 821 2382

Spain: Balmes 22, 08007 BARCELONA, Tel. +34 93 301 6312, Fax. +34 93 301 4107

Sweden: Kottbygatan 7, Akalla, S-16485 STOCKHOLM, Tel. +46 8 5985 2000, Fax. +46 8 5985 2745

Switzerland: Allmendstrasse 140, CH-8027 ZÜRICH, Tel. +41 1 488 2741 Fax. +41 1 488 3263

Taiwan: Philips Semiconductors, 6F, No. 96, Chien Kuo N. Rd., Sec. 1, TAIPEI, Taiwan Tel. +886 2 2134 2865, Fax. +886 2 2134 2874

Thailand: PHILIPS ELECTRONICS (THAILAND) Ltd., 209/2 Sanpavuth-Bangna Road Prakanong, BANGKOK 10260, Tel. +66 2 745 4090, Fax. +66 2 398 0793

Turkey: Talatpasa Cad. No. 5, 80640 GÜLTEPE/ISTANBUL, Tel. +90 212 279 2770, Fax. +90 212 282 6707

Ukraine: PHILIPS UKRAINE, 4 Patrice Lumumba str., Building B, Floor 7, 252042 KIEV, Tel. +380 44 264 2776, Fax. +380 44 268 0461

United Kingdom: Philips Semiconductors Ltd., 276 Bath Road, Hayes, MIDDLESEX UB3 5BX, Tel. +44 181 730 5000, Fax. +44 181 754 8421

United States: 811 East Arques Avenue, SUNNYVALE, CA 94088-3409, Tel. +1 800 234 7381

Uruguay: see South America

Vietnam: see Singapore

Yugoslavia: PHILIPS, Trg N. Pasica 5/v, 11000 BEOGRAD, Tel. +381 11 625 344, Fax. +381 11 635 777

For all other countries apply to: Philips Semiconductors, International Marketing & Sales Communications, Building BE-p, P.O. Box 218, 5600 MD EINDHOVEN, The Netherlands, Fax. +31 40 27 24825

Internet: <http://www.semiconductors.philips.com>

© Philips Electronics N.V. 1998

SCA60

All rights are reserved. Reproduction in whole or in part is prohibited without the prior written consent of the copyright owner.

The information presented in this document does not form part of any quotation or contract, is believed to be accurate and reliable and may be changed without notice. No liability will be accepted by the publisher for any consequence of its use. Publication thereof does not convey nor imply any license under patent- or other industrial or intellectual property rights.

Printed in The Netherlands

545102/750/02/pp20

Date of release: 1998 Sep 23

Document order number: 9397 750 04369

Let's make things better.

**Philips
Semiconductors**



PHILIPS