

DISCRETE SEMICONDUCTORS

DATA SHEET

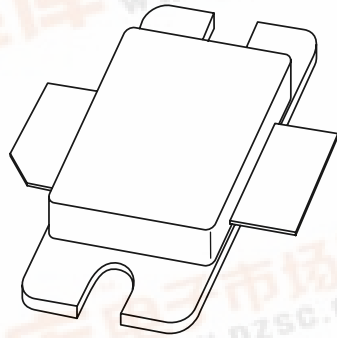

BLF2022-125 **UHF power LDMOS transistor**

Objective specification
Supersedes data of 2002 April 02

2003 Mar 07

UHF power LDMOS transistor

BLF2022-125

FEATURES

- Typical W-CDMA performance at a supply voltage of 28 V and I_{DQ} of 1 A
 - Output power = 20 W (AV)
 - Gain = 12 dB
 - Efficiency = 19%
 - ACPR = -42 dBc at 3.84 MHz
- Easy power control
- Excellent ruggedness
- High power gain
- Excellent thermal stability
- Designed for broadband operation (2000 to 2200 MHz)
- Internally matched for ease of use.

APPLICATIONS

- RF power amplifiers for W-CDMA base stations and multicarrier applications in the 2000 to 2200 MHz frequency range

DESCRIPTION

125 W LDMOS power transistor for base station applications at frequencies from 2000 to 2200 MHz.

QUICK REFERENCE DATA

RF performance at $T_h = 25\text{ }^\circ\text{C}$ in a common source test circuit; single-carrier W-CDMA test model 1, 64 channels, 3.84 MHz channel bandwidth; Peak/Average = 9.8 dB at 0.01% probability on CCDF.

MODE OF OPERATION	f (MHz)	V_{DS} (V)	$P_{L\text{ avg}}$ (W)	G_p (dB)	η_D (%)	d_{im} (dBc)
single carrier W-CDMA	2110 to 2170	28	30	typ 12	typ 19	typ -42

LIMITING VALUES

In accordance with the Absolute Maximum Rating System (IEC 60134).

SYMBOL	PARAMETER	MIN.	MAX.	UNIT
V_{DS}	drain-source voltage	-	65	V
V_{GS}	gate-source voltage	-	±15	V
I_D	drain current (DC)	-	tbd	A
T_{stg}	storage temperature	-65	+150	°C
T_j	junction temperature	-	200	°C

PINNING - SOT634A

PIN	DESCRIPTION
1	drain
2	gate
3	source, connected to flange

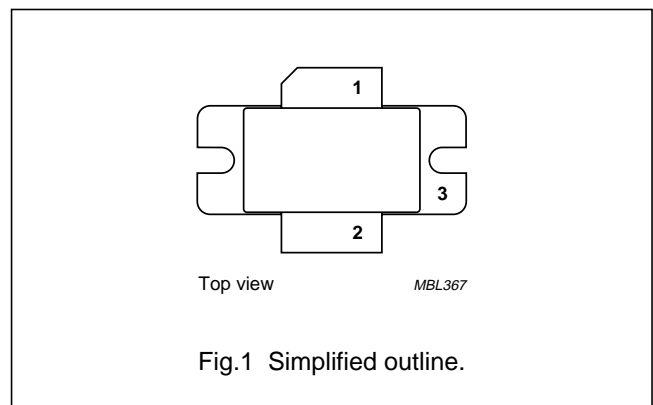

CAUTION

This product is supplied in anti-static packing to prevent damage caused by electrostatic discharge during transport and handling. For further information, refer to Philips specs.: SNW-EQ-608, SNW-FQ-302A and SNW-FQ-302B.

UHF power LDMOS transistor

BLF2022-125

THERMAL CHARACTERISTICS

SYMBOL	PARAMETER	CONDITIONS	VALUE	UNIT
$R_{th\ j-c}$	thermal resistance from junction to case	note 1	0.55	K/W

Note

1. Thermal resistance is determined under specified RF operating conditions.

CHARACTERISTICS

$T_j = 25\text{ }^\circ\text{C}$ unless otherwise specified.

SYMBOL	PARAMETER	CONDITIONS	MIN.	TYP.	MAX.	UNIT
$V_{(BR)DSS}$	drain-source breakdown voltage	$V_{GS} = 0; I_D = 2.5\text{ mA}$	65	–	–	V
V_{GSth}	gate-source threshold voltage	$V_{DS} = 10\text{ V}; I_D = 240\text{ mA}$	4.5	–	5.5	V
I_{DSS}	drain-source leakage current	$V_{GS} = 0; V_{DS} = 26\text{ V}$	–	–	10	μA
I_{GSS}	gate leakage current	$V_{GS} = \pm 15\text{ V}; V_{DS} = 0$	–	–	40	nA
g_{fs}	forward transconductance	$V_{DS} = 10\text{ V}; I_D = 16\text{ A}$	–	9.5	–	S
R_{DSon}	drain-source on-state resistance	$V_{GS} = V_{GSth} + 9\text{ V}; I_D = 8\text{ A}$	–	0.07	–	Ω
C_{rss}	feedback capacitance	$V_{GS} = 0; V_{DS} = 26\text{ V}; f = 1\text{ MHz}$	–	tbd	–	pF

UHF power LDMOS transistor

BLF2022-125

APPLICATION INFORMATION

RF performance at $T_h = 25\text{ }^\circ\text{C}$ in a common source test circuit; single-carrier W-CDMA test model 1, 64 channels, with 68% clipping, 3.84 MHz channel bandwidth; Peak/Average = 8.5 dB at 0.01% probability on CCDF.

SYMBOL	PARAMETER	CONDITIONS	MIN.	TYP.	MAX.	UNIT
G_p	common-source power gain	$V_D = 28\text{ V}$; $P_{out} = 20\text{ W (AV)}$, single carrier W-CDMA; $I_{DQ} = 1000\text{ mA}$; $f = 2.11\text{ to }2.17\text{ GHz}$	11	12	–	dB
η_D	drain efficiency	$V_D = 28\text{ V}$; $P_{out} = 20\text{ W (AV)}$, single carrier W-CDMA; $I_{DQ} = 1000\text{ mA}$; $f = 2.11\text{ to }2.17\text{ GHz}$	17	19	–	%
ACPR	adjacent channel power ratio	$V_D = 28\text{ V}$; $P_{out} = 20\text{ W (AV)}$, single carrier W-CDMA; $I_{DQ} = 1000\text{ mA}$; $f = 2.11\text{ to }2.17\text{ GHz}$	–	–49	–39	dBc
I_{RL}	input return loss	$V_D = 28\text{ V}$; $P_{out} = 20\text{ W (AV)}$, single carrier W-CDMA; $I_{DQ} = 1000\text{ mA}$; $f = 2.11\text{ to }2.17\text{ GHz}$	–	–10	–6	dB
ψ	output mismatch	$V_D = 28\text{ V}$; $P_{out} = 20\text{ W (AV)}$ single carrier W-CDMA; VSWR = 5:1 through all phases	no degradation in RF performance before and after test			

RF performance at $T_h = 25\text{ }^\circ\text{C}$ in a common source test circuit; two-carrier W-CDMA signals, 3GPP test mode 1 64 channels, with 68% clipping, 3.84 MHz channel bandwidth; Peak/Average = 8.5 dB at 0.01% probability on CCDF per channel frequency range is 2.11 GHz to 2.17 GHz; carrier spacing is 10 MHz.

SYMBOL	PARAMETER	CONDITIONS	MIN.	TYP.	MAX.	UNIT
G_p	common-source power gain	$V_D = 28\text{ V}$; $P_{out} = 20\text{ W (AV)}$; $I_{DQ} = 1000\text{ mA}$	–	12	–	dB
η_D	drain efficiency	$V_D = 28\text{ V}$; $P_{out} = 20\text{ W (AV)}$; $I_{DQ} = 1000\text{ mA}$	–	19	–	%
ACPR	adjacent channel power ratio	$V_D = 28\text{ V}$; $P_{out} = 20\text{ W (AV)}$; $I_{DQ} = 1000\text{ mA}$; ACPR is measured at $f_1 = -5\text{ MHz}$ and $f_2 = +5\text{ MHz}$	–	–40	–	dBc
d_3	third order intermodulation distortion	$V_D = 28\text{ V}$; $P_{out} = 20\text{ W (AV)}$; $I_{DQ} = 1000\text{ mA}$; ACPR is measured at $f_1 = -10\text{ MHz}$ and $f_2 = +10\text{ MHz}$	–	–36	–	dB
I_{RL}	input return loss	$V_D = 28\text{ V}$; $P_{out} = 20\text{ W (AV)}$; $I_{DQ} = 1000\text{ mA}$	–	–10	–	dB

UHF power LDMOS transistor

BLF2022-125

PACKAGE OUTLINE

Flanged ceramic package; 2 mounting holes; 2 leads

SOT634A

Package under development

Philips Semiconductors reserves the right to make changes without notice.

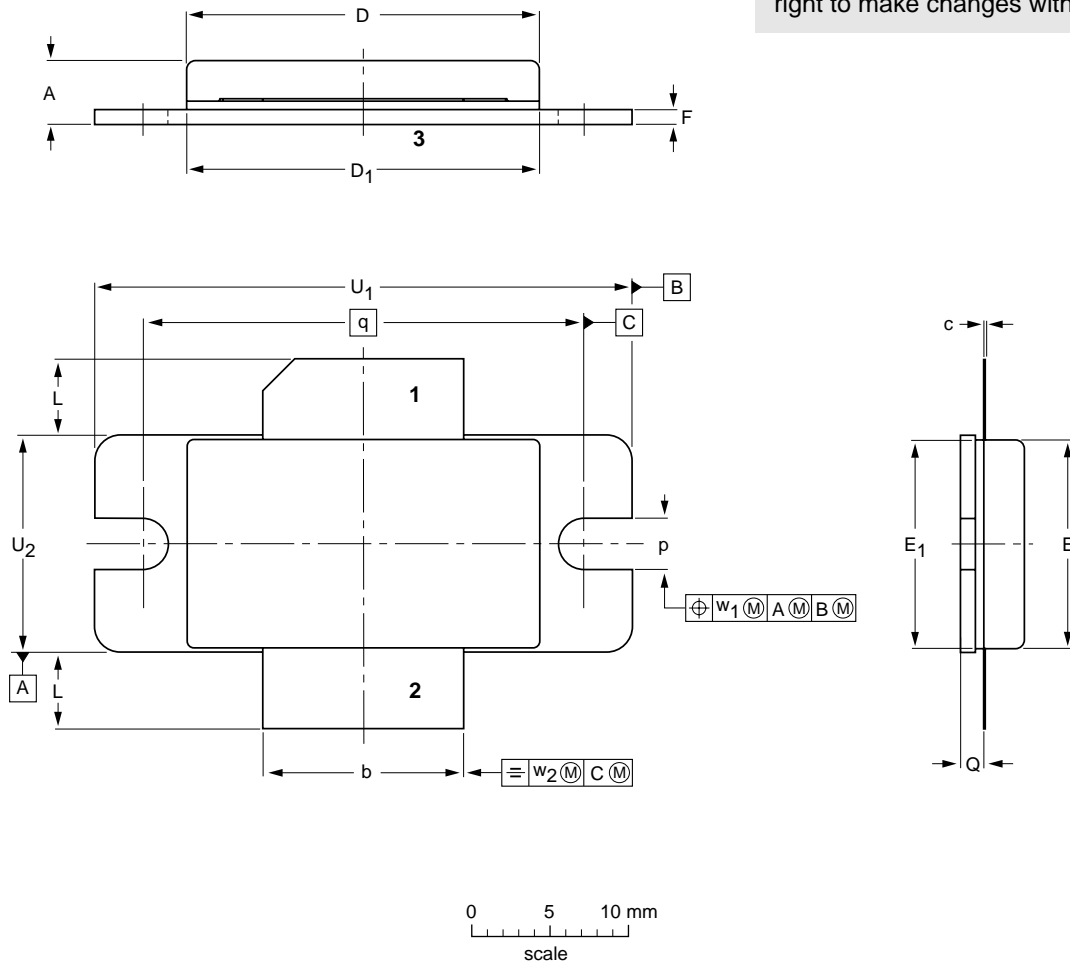

DIMENSIONS (millimetre dimensions are derived from the original inch dimensions)

UNIT	A	b	c	D	D ₁	E	E ₁	F	L	p	Q	q	U ₁	U ₂	w ₁	w ₂
mm	4.83 3.68	12.82 12.57	0.15 0.08	22.58 22.12	22.56 22.15	13.34 13.08	13.34 13.08	1.14 0.89	5.33 4.32	3.38 3.12	1.70 1.45	27.94	34.16 33.91	13.84 13.59	0.25	0.51
inches	0.190 0.145	0.505 0.495	0.006 0.003	0.889 0.871	0.888 0.872	0.525 0.515	0.525 0.515	0.045 0.035	0.210 0.170	0.133 0.123	0.067 0.057	1.100	1.345 1.335	0.545 0.535	0.010	0.020

OUTLINE VERSION	REFERENCES				EUROPEAN PROJECTION	ISSUE DATE
	IEC	JEDEC	EIAJ			
SOT634A						01-11-27

UHF power LDMOS transistor

BLF2022-125

DATA SHEET STATUS

LEVEL	DATA SHEET STATUS ⁽¹⁾	PRODUCT STATUS ⁽²⁾⁽³⁾	DEFINITION
I	Objective data	Development	This data sheet contains data from the objective specification for product development. Philips Semiconductors reserves the right to change the specification in any manner without notice.
II	Preliminary data	Qualification	This data sheet contains data from the preliminary specification. Supplementary data will be published at a later date. Philips Semiconductors reserves the right to change the specification without notice, in order to improve the design and supply the best possible product.
III	Product data	Production	This data sheet contains data from the product specification. Philips Semiconductors reserves the right to make changes at any time in order to improve the design, manufacturing and supply. Relevant changes will be communicated via a Customer Product/Process Change Notification (CPCN).

Notes

1. Please consult the most recently issued data sheet before initiating or completing a design.
2. The product status of the device(s) described in this data sheet may have changed since this data sheet was published. The latest information is available on the Internet at URL <http://www.semiconductors.philips.com>.
3. For data sheets describing multiple type numbers, the highest-level product status determines the data sheet status.

DEFINITIONS

Short-form specification — The data in a short-form specification is extracted from a full data sheet with the same type number and title. For detailed information see the relevant data sheet or data handbook.

Limiting values definition — Limiting values given are in accordance with the Absolute Maximum Rating System (IEC 60134). Stress above one or more of the limiting values may cause permanent damage to the device. These are stress ratings only and operation of the device at these or at any other conditions above those given in the Characteristics sections of the specification is not implied. Exposure to limiting values for extended periods may affect device reliability.

Application information — Applications that are described herein for any of these products are for illustrative purposes only. Philips Semiconductors make no representation or warranty that such applications will be suitable for the specified use without further testing or modification.

DISCLAIMERS

Life support applications — These products are not designed for use in life support appliances, devices, or systems where malfunction of these products can reasonably be expected to result in personal injury. Philips Semiconductors customers using or selling these products for use in such applications do so at their own risk and agree to fully indemnify Philips Semiconductors for any damages resulting from such application.

Right to make changes — Philips Semiconductors reserves the right to make changes in the products - including circuits, standard cells, and/or software - described or contained herein in order to improve design and/or performance. When the product is in full production (status 'Production'), relevant changes will be communicated via a Customer Product/Process Change Notification (CPCN). Philips Semiconductors assumes no responsibility or liability for the use of any of these products, conveys no licence or title under any patent, copyright, or mask work right to these products, and makes no representations or warranties that these products are free from patent, copyright, or mask work right infringement, unless otherwise specified.

UHF power LDMOS transistor

BLF2022-125

NOTES

Philips Semiconductors – a worldwide company

Contact information

For additional information please visit <http://www.semiconductors.philips.com>. Fax: +31 40 27 24825

For sales offices addresses send e-mail to: sales.addresses@www.semiconductors.philips.com.

© Koninklijke Philips Electronics N.V. 2003

SCA75

All rights are reserved. Reproduction in whole or in part is prohibited without the prior written consent of the copyright owner.

The information presented in this document does not form part of any quotation or contract, is believed to be accurate and reliable and may be changed without notice. No liability will be accepted by the publisher for any consequence of its use. Publication thereof does not convey nor imply any license under patent- or other industrial or intellectual property rights.

Printed in The Netherlands

613524/03/pp8

Date of release: 2003 Mar 07

Document order number: 9397 750 10919

Let's make things better.