

| | |
|---|--|
|  | <h1 style="margin: 0;">AK4538</h1> <h2 style="margin: 0;">16Bit $\Delta\Sigma$ CODEC with MIC/HP/SPK-AMP</h2> |
|---|--|

| |
|----------------------------|
| GENERAL DESCRIPTION |
|----------------------------|

The AK4538 targeted at PDA and other low-power, small size applications. It features a 16-bit stereo CODEC with a built-in Microphone-Amplifier, Headphone-Amplifier and Speaker-Amplifier. Input circuits include a Microphone-Amplifier and an ALC (Auto Level Control) circuit. The AK4538 is available in a 52-QFN, utilizing less board space than competitive offerings.

| |
|-----------------|
| FEATURES |
|-----------------|

1. Resolution : 16bits
2. Recording Function
 - 1ch Mono Input
 - 2-Input Selector(Internal MIC, External MIC)
 - 1st MIC Amplifier : +20dB or 0dB
 - 2nd Amplifier with ALC : -8dB ~ +27.5dB, 0.5dB Step, Mute
 - ADC Performance : S/(N+D) : 79dB, DR, S/N : 83dB
3. Playback Function
 - Digital De-emphasis Filter (tc=50/15ms, fs=32kHz, 44.1kHz, 48kHz)
 - Digital Volume (0dB ~ -127dB, 0.5dB Step, Mute)
 - Low Frequency Boost Function
 - Mono Line Output
 - Differential Output
 - Performance : S/(N+D) : 89dB, S/N : 95dB
 - Stereo Line Output
 - Performance : S/(N+D) : 88dB, S/N : 92dB
 - Headphone-Amp
 - S/(N+D) : 70dB, S/N : 90dB
 - Output Power : 15mW@16W (HVDD=3.3V)
 - Mono Speaker-Amp with ALC
 - S/(N+D) : 64dB, S/N : 90dB
 - BTL Output
 - Output Power : 150mW@8W (HVDD=3.3V)
 - Mono and Stereo Beep Inputs
 - AUX Input
 - Differential Input
 - -21dB ~ +24dB, Step 3dB, Mute
4. Power Management
5. Master Clock
 - (1) PLL Mode
 - Frequencies : 11.2896MHz, 12MHz and 12.288MHz
 - Input Level : CMOS
 - (2) External Clock Mode
 - Frequencies : 1.792MHz ~ 12.288MHz
6. Output Master Clock Frequencies : 32fs/64fs/128fs/256fs
7. Sampling Rate
 - (1) PLL Mode
 - 8kHz, 11.025kHz, 16kHz, 22.05kHz, 24kHz, 32kHz, 44.1kHz, 48kHz
 - (2) External Clock Mode
 - 7kHz ~ 48kHz
8. Control mode: 4-wire Serial / I²C Bus
9. Master/Slave mode



10. Audio Interface Format : MSB First, 2's compliment
 - ADC : I²S, 16bit MSB justified
 - DAC : I²S, 16bit MSB justified, 16bit LSB justified
11. Ta = -10 ~ 70°C
12. Power Supply: 2.4V ~ 3.6V (typ. 3.3V)
13. Power Supply Current
 - AVDD+DVDD : 16mA
 - PVDD : 1.2mA
 - HVDD (HP-AMP=ON, SPK-AMP=OFF) : 6.5mA
 - HVDD (HP-AMP=OFF, SPK-AMP=ON) : 9mA
14. Package : 52pin QFN
15. AK4534 Pin Compatible

■ Block Diagram

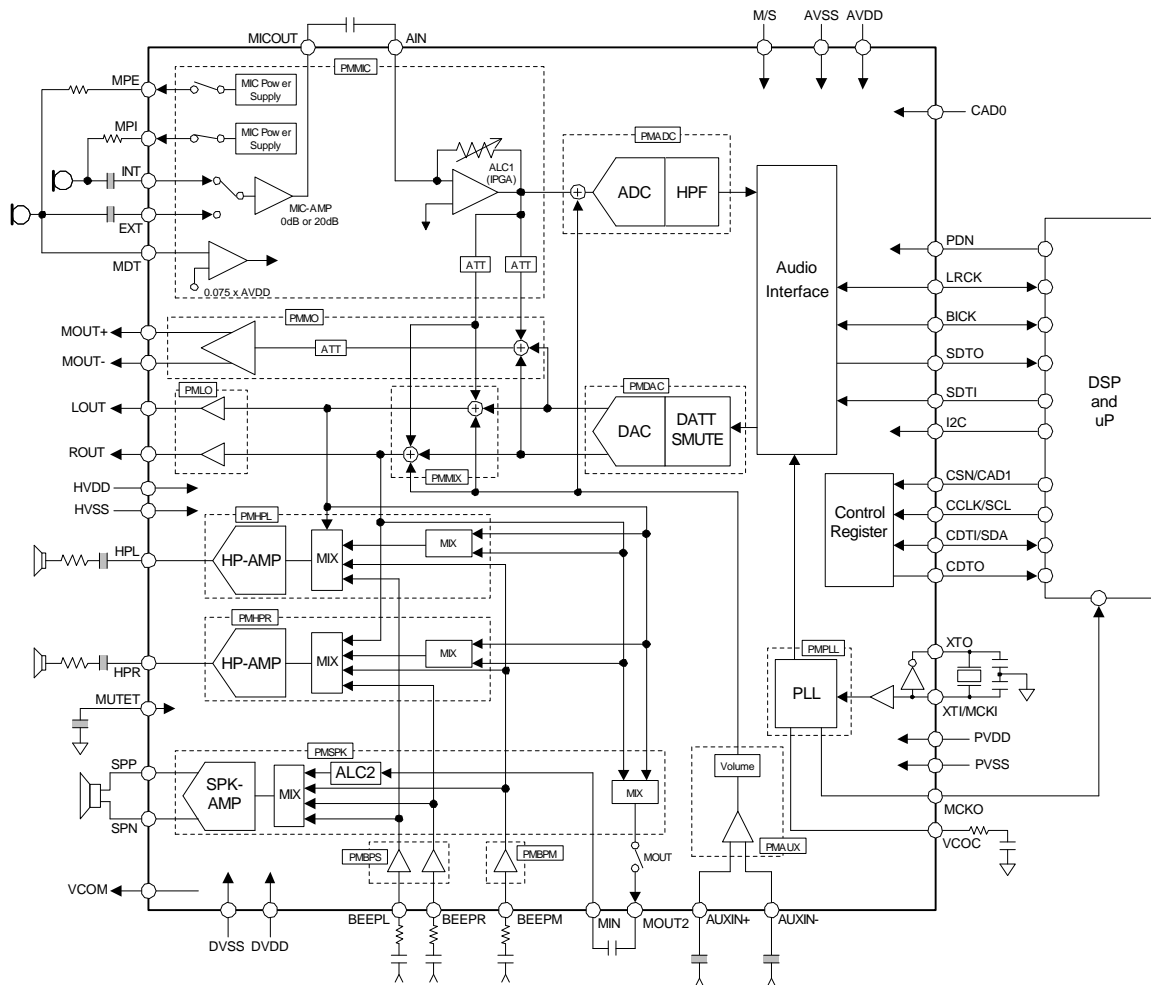
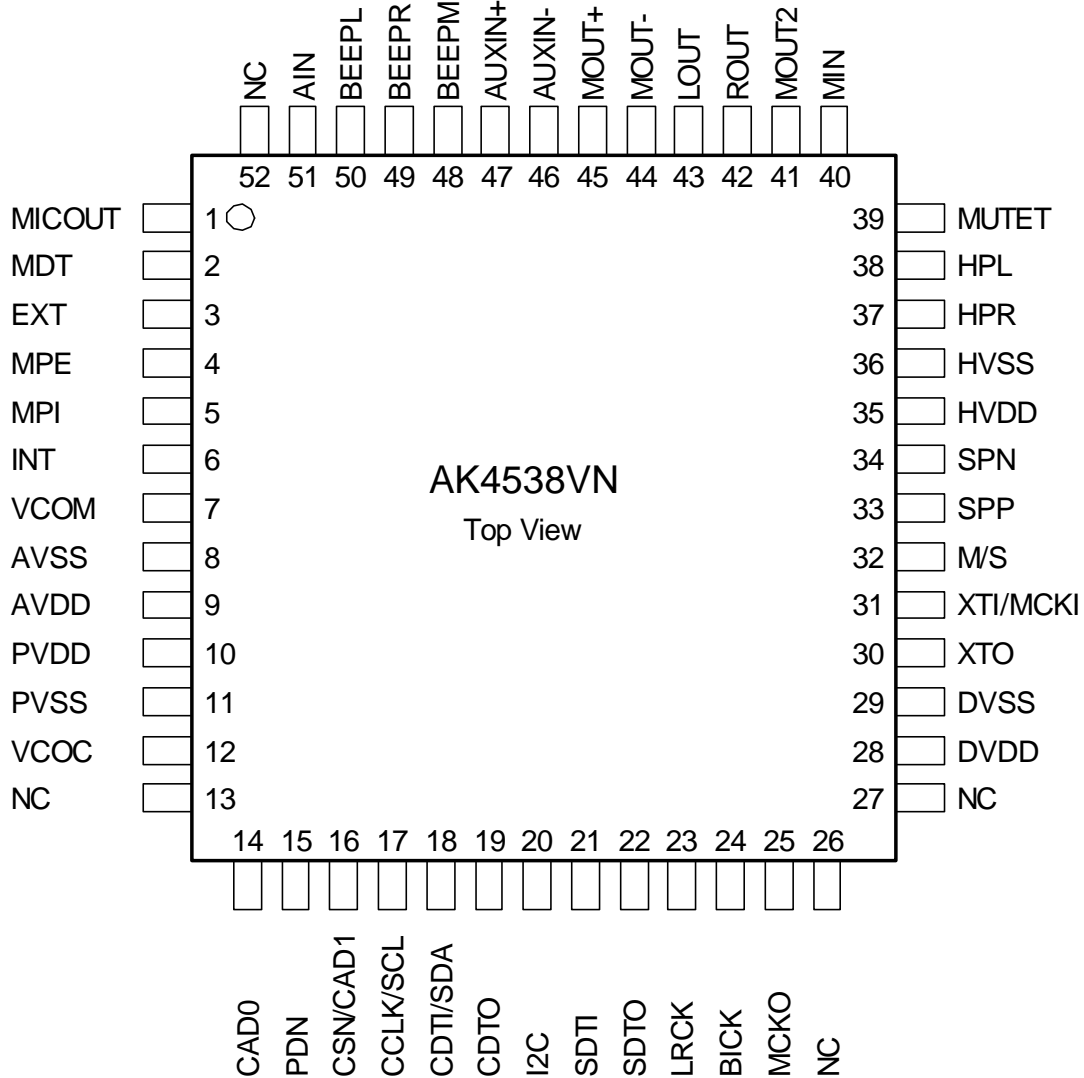

Figure 1. Block Diagram

■ Ordering Guide

| | | |
|----------|-----------------------------|-------------------------|
| AK4538VN | -10 ~ +70°C | 52pin QFN (0.4mm pitch) |
| AKD4538 | Evaluation board for AK4538 | |

■ Pin Layout (52pin QFN)



| |
|------------------------------|
| PIN/FUNCTION of 52QFN |
|------------------------------|

| No. | Pin Name | I/O | Function |
|-----|----------|-----|--|
| 1 | MICOUT | O | Microphone Analog Output Pin |
| 2 | MDT | I | Microphone Detect Pin (Internal pull down by 500kΩ) |
| 3 | EXT | I | External Microphone Input Pin (Mono Input) |
| 4 | MPE | O | MIC Power Supply Pin for External Microphone |
| 5 | MPI | O | MIC Power Supply Pin for Internal Microphone |
| 6 | INT | I | Internal Microphone Input Pin (Mono Input) |
| 7 | VCOM | O | Common Voltage Output Pin, AVDD/2 Bias voltage of ADC inputs and DAC outputs. |
| 8 | AVSS | - | Analog Ground Pin |
| 9 | AVDD | - | Analog Power Supply Pin |
| 10 | PVDD | - | PLL Power Supply Pin |
| 11 | PVSS | - | PLL Ground Pin |
| 12 | VCOC | O | Output Pin for Loop Filter of PLL Circuit This pin should be connected to PVSS with one resistor and capacitor in series. |
| 13 | NC | - | No Connect. No internal bonding. |
| 14 | CAD0 | I | Chip Address 0 Select Pin |
| 15 | PDN | I | Power-Down Mode Pin “H”: Power up, “L”: Power down reset and initializes the control register. |
| 16 | CSN | I | Chip Select Pin (I2C = “L”) |
| | CAD1 | I | Chip Address 1 Select Pin (I2C = “H”) |
| 17 | CCLK | I | Control Data Clock Pin (I2C = “L”) |
| | SCL | I | Control Data Clock Pin (I2C = “H”) |
| 18 | CDTI | I | Control Data Input Pin (I2C = “L”) |
| | SDA | I/O | Control Data Input Pin (I2C = “H”) |
| 19 | CDTO | O | Control Data Output Pin (I2C = “L”) |
| 20 | I2C | I | Control Mode Select Pin “H”: I ² C Bus, “L”: 4-wire Serial |
| 21 | SDTI | I | Audio Serial Data Input Pin |
| 22 | SDTO | O | Audio Serial Data Output Pin |
| 23 | LRCK | I/O | Input / Output Channel Clock Pin |
| 24 | BICK | I/O | Audio Serial Data Clock Pin |
| 25 | MCKO | O | Master Clock Output Pin |
| 26 | NC | - | No Connect. No internal bonding. |

| No. | Pin Name | I/O | Function |
|-----|----------|-----|--|
| 27 | NC | - | No Connect. No internal bonding. |
| 28 | DVDD | - | Digital Power Supply Pin |
| 29 | DVSS | - | Digital Ground Pin |
| 30 | XTO | O | X'tal Output Pin |
| 31 | XTI | I | X'tal Input Pin |
| | MCKI | I | External Master Clock Input Pin |
| 32 | M/S | I | Master / Slave Mode Pin “H” : Master Mode, “L” : Slave Mode |
| 33 | SPP | O | Speaker Amp Positive Output Pin |
| 34 | SPN | O | Speaker Amp Negative Output Pin |
| 35 | HVDD | - | Headphone Amp Power Supply Pin |
| 36 | HVSS | - | Headphone Amp Ground Pin |
| 37 | HPR | O | Rch Headphone Amp Output Pin |
| 38 | HPL | O | Lch Headphone Amp Output Pin |
| 39 | MUTET | O | Mute Time Constant Control Pin Connected to HVSS pin with a capacitor for mute time constant. |
| 40 | MIN | I | ALC Input Pin |
| 41 | MOU2 | O | Analog Mixing Output Pin |
| 42 | ROUT | O | Line Out Right Channel |
| 43 | LOUT | O | Line Out Left Channel |
| 44 | MOU- | O | Mono Line Negative Output Pin |
| 45 | MOU+ | O | Mono Line Positive Output Pin |
| 46 | AUXIN- | I | Mono AUX Negative Input Pin |
| 47 | AUXIN+ | I | Mono AUX Positive Input Pin |
| 48 | BEEPM | I | Mono Beep Signal Input Pin |
| 49 | BEEPR | I | Rch Stereo Beep Signal Input Pin |
| 50 | BEEPL | I | Lch Stereo Beep Signal Input Pin |
| 51 | AIN | I | Analog Input Pin |
| 52 | NC | - | No Connect. No internal bonding. |

Note: All input pins except analog input pins (INT, EXT, AIN, MIN, AUXIN+, AUXIN-, BEEPM, BEEPL, and BEEPR) should not be left floating.

| |
|---------------------------------|
| ABSOLUTE MAXIMUM RATINGS |
|---------------------------------|

(AVSS, DVSS, PVSS, HVSS=0V; Note 1)

| Parameter | | Symbol | min | max | Units |
|--|-----------------------------|---------------|------|----------|-------|
| Power Supplies: | Analog | AVDD | -0.3 | 4.6 | V |
| | Digital | DVDD | -0.3 | 4.6 | V |
| | PLL | PVDD | -0.3 | 4.6 | V |
| | Headphone-Amp / Speaker-Amp | HVDD | -0.3 | 4.6 | V |
| | AVSS – PVSS (Note 2) | Δ GND1 | - | 0.3 | V |
| | AVSS – DVSS (Note 2) | Δ GND2 | - | 0.3 | V |
| | AVSS – HVSS (Note 2) | Δ GND3 | - | 0.3 | V |
| Input Current, Any Pin Except Supplies | | IIN | - | \pm 10 | mA |
| Analog Input Voltage | | VINA | -0.3 | AVDD+0.3 | V |
| Digital Input Voltage | | VIND | -0.3 | DVDD+0.3 | V |
| Ambient Temperature (powered applied) | | Ta | -10 | 70 | °C |
| Storage Temperature | | Tstg | -65 | 150 | °C |

Note 1. All voltages with respect to ground.

Note 2. AVSS, DVSS, PVSS and HVSS must be connected to the same analog ground plane.

WARNING: Operation at or beyond these limits may result in permanent damage to the device.
Normal operation is not guaranteed at these extremes.

| |
|---|
| RECOMMENDED OPERATING CONDITIONS |
|---|

(AVSS, DVSS, PVSS, HVSS=0V; Note 1)

| Parameter | | Symbol | min | typ | max | Units |
|----------------------------|--------------|--------|-----|-----|------|-------|
| Power Supplies (Note 3) | Analog | AVDD | 2.4 | 3.3 | 3.6 | V |
| | Digital | DVDD | 2.4 | 3.3 | AVDD | V |
| | PLL | PVDD | 2.4 | 3.3 | AVDD | V |
| | HP / SPK-Amp | HVDD | 2.4 | 3.3 | AVDD | V |

Note 1. All voltages with respect to ground.

Note 3. The power up sequence between AVDD, DVDD, HVDD and PVDD is not critical.

It is recommended that DVDD and PVDD are the same voltage as AVDD in order to reduce the current at power down mode.

* AKM assumes no responsibility for the usage beyond the conditions in this datasheet.

| |
|-------------------------------|
| ANALOG CHARACTERISTICS |
|-------------------------------|

(Ta=25°C; AVDD=DVDD=PVDD=HVDD=3.3V; AVSS=DVSS=PVSS=HVSS=0V; fs=44.1kHz, BICK=64fs;
Signal Frequency=1kHz; 16bit Data; Measurement frequency=20Hz ~ 20kHz; unless otherwise specified)

| Parameter | min | typ | max | Units | |
|--|---------------|-------|-------|-------|------|
| MIC Amplifier | | | | | |
| Input Resistance | 20 | 30 | 40 | kΩ | |
| Gain (MGAIN bit = "0") | - | 0 | - | dB | |
| Gain (MGAIN bit = "1") | - | 20 | - | dB | |
| MIC Power Supply | | | | | |
| Output Voltage (Note 4) | 2.22 | 2.47 | 2.72 | V | |
| Output Current | - | - | 1.25 | mA | |
| MIC Detection | | | | | |
| Comparator Voltage Level (Note 5) | 0.165 | | 0.247 | mV | |
| Internal pull down Resistance | 250 | 500 | 750 | kΩ | |
| Input PGA Characteristics: | | | | | |
| Input Resistance (Note 6) | 5 | 10 | 15 | kΩ | |
| Step Size | 0.1 | 0.5 | 0.9 | dB | |
| Gain Control Range | -8 | | +27.5 | dB | |
| ADC Analog Input Characteristics: MIC Gain=20dB, IPGA=0dB, ALC1=OFF, MIC → IPGA → ADC | | | | | |
| Resolution | | | 16 | Bits | |
| Input Voltage (MIC Gain=20dB, Note 7) | 0.168 | 0.198 | 0.228 | Vpp | |
| S/(N+D) (-1dBFS) | 71 | 79 | | dB | |
| D-Range (-60dBFS, A-weighted) | 75 | 83 | | dB | |
| S/N (A-weighted) | 75 | 83 | | dB | |
| DAC Characteristics: | | | | | |
| Resolution | | | 16 | Bits | |
| Stereo Line Output Characteristics: RL=10kΩ, DAC → LOUT/ROUT | | | | | |
| Output Voltage (Note 8) | 1.74 | 1.94 | 2.14 | Vpp | |
| S/(N+D) (-3dBFS) | 78 | 88 | | dBFS | |
| S/N (A-weighted) | 85 | 92 | | dB | |
| Interchannel Gain Mismatch | | 0.1 | 0.5 | dB | |
| Load Resistance | 10 | | | kΩ | |
| Load Capacitance | | | 30 | pF | |
| Mono Line Output Characteristics: RL=20kΩ, DAC → MOUT+/MOUT- | | | | | |
| Output Voltage (Note 9) | MOGN=1, -17dB | - | 0.31 | - | Vpp |
| | MOGN=0, +6dB | 3.56 | 3.96 | 4.36 | Vpp |
| S/(N+D) (-3dBFS) | MOGN=1, -17dB | | 76 | | dBFS |
| | MOGN=0, +6dB | 79 | 89 | | dBFS |
| S/N (A-weighted) | MOGN=1, -17dB | - | 79 | | dB |
| | MOGN=0, +6dB | 85 | 95 | | dB |
| Load Resistance | MOGN=1, -17dB | 2 | | | kΩ |
| | MOGN=0, +6dB | 20 | | | kΩ |
| Load Capacitance | | | 30 | pF | |

Note 4. Output voltage is proportional to AVDD voltage. $V_{out} = 0.75 \times AVDD$.

Note 5. Comparator Voltage Level is proportional to AVDD voltage. $V_{out} = 0.05 \times AVDD(\min)$, $0.075 \times AVDD(\max)$.

Note 6. When IPGA Gain is changed, this typical value changes between 8kΩ and 11kΩ.

Note 7. Input voltage is proportional to AVDD voltage. $V_{in} = 0.06 \times AVDD$.

Note 8. Output voltage is proportional to AVDD voltage. $V_{out} = 0.588 \times AVDD$.

Note 9. Output voltage is proportional to AVDD voltage. $V_{out} = 1.2 \times AVDD(\text{typ})@MOGN=0$,
 $0.094 \times AVDD(\text{typ})@MOGN=1$ at Full-differential output.

$V_{out} = 0.6 \times AVDD(\text{typ})@MOGN=0$, $0.047 \times AVDD(\text{typ})@MOGN=1$ at Single-end Output.

| Parameter | min | typ | max | Units |
|--|------|------|------|-----------------|
| Headphone-Amp Characteristics: $R_L=22.8\Omega$, DAC \rightarrow HPL/HPR, DATT=0dB | | | | |
| Output Voltage (Note 10) | 1.54 | 1.92 | 2.30 | V _{pp} |
| S/(N+D) (-3dBFS) | 60 | 70 | | dBFS |
| S/N (A-weighted) | 80 | 90 | | dB |
| Interchannel Isolation | 70 | 85 | | dB |
| Interchannel Gain Mismatch | | 0.1 | 0.5 | dB |
| Load Resistance | 20 | | | Ω |
| Load Capacitance (C1 of Figure 2) | | | 30 | pF |
| (C2 of Figure 2) | | | 300 | pF |
| Speaker-Amp Characteristics: $R_L=8\Omega$, BTL, DAC \rightarrow MOUT2 \rightarrow MIN \rightarrow SPP/SPN, ALC2=OFF | | | | |
| Output Voltage (Note 11) | 2.37 | 2.96 | 3.55 | V _{pp} |
| S/(N+D) | 50 | 64 | | dB |
| S/N (A-weighted) | 82 | 90 | | dB |
| Load Resistance | 8 | | | Ω |
| Load Capacitance | | | 30 | pF |
| AUX Input: AUXIN+, AUXIN- pin | | | | |
| Maximum Input Voltage (Note 12) | | | 1.98 | V _{pp} |
| Input Resistance | 25 | 40 | 55 | k Ω |
| Step Size | 1 | 3 | 5 | dB |
| Gain Control Range | -21 | | +24 | dB |
| BEEP Input: BEEPL, BEEPR, BEEPM pin | | | | |
| Maximum Input Voltage (Note 13) | | | 1.98 | V _{pp} |
| Feedback Resistance | 14 | 20 | 26 | k Ω |
| Mono Input: MIN pin | | | | |
| Maximum Input Voltage (Note 14) | | | 1.98 | V _{pp} |
| Input Resistance (Note 15) | 12 | 24 | 36 | k Ω |
| Mono Output: $R_L=10k\Omega$, DAC \rightarrow MIX \rightarrow MOUT2 | | | | |
| Output Voltage (Note 16) | | 1.94 | | V _{pp} |
| Load Resistance | 10 | | | k Ω |
| Load Capacitance (Note 17) | | | 30 | pF |

Note 10. Output voltage is proportional to AVDD voltage. $V_{out} = 0.582 \times AVDD$.

Note 11. Output voltage is proportional to HVDD voltage. $V_{out} = 0.897 \times HVDD$ at Full-differential output.

Note 12. Maximum Input Voltage is proportional to AVDD voltage. $V_{in} = 0.6 \times AVDD$.

Note 13. Maximum Input Voltage is proportional to AVDD voltage. $V_{in} = 0.6 \times AVDD$. BEEP-AMP can't output more than this maximum voltage.

Note 14. Maximum Input Voltage is proportional to AVDD voltage. $V_{in} = 0.6 \times AVDD$.

Note 15. When ALC2 Gain is changed, this typical value changes between 22k Ω and 26k Ω .

Note 16. Output Voltage is proportional to AVDD voltage. $V_{out} = 0.588 \times AVDD$.

Note 17. When the output pin drives a capacitive load, a resistor should be added in series between the output pin and capacitive load.

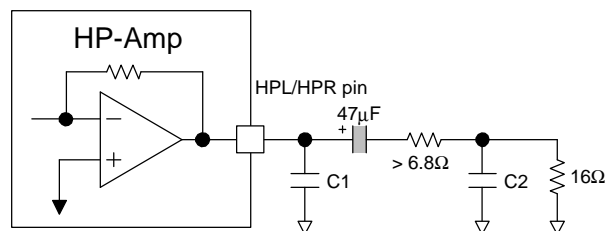

Figure 2. Headphone-amp output circuit

| Parameter | min | typ | max | Units |
|---|-----|-----|-----|-------|
| Power Supplies | | | | |
| Power Up (PDN = "H") | | | | |
| AVDD+DVDD (Note 18) | | 16 | 26 | mA |
| PVDD | | 1.2 | 2 | mA |
| HVDD: HP-AMP Normal Operation No Output (Note 19) | | 6.5 | 10 | mA |
| HVDD: SPK-AMP Normal Operation No Output (Note 20) | | 9 | 18 | mA |
| Power Down (PDN = "L") (Note 21) | | | | |
| AVDD+DVDD | | 10 | 100 | μA |
| PVDD | | 10 | 100 | μA |
| HVDD | | 10 | 100 | μA |

Note 18. PMMIC=PMADC=PMDAC=PMMO=PMSPK=PMHPL=PMHPR=PMVCM=PMPLL=PMXTL=PMBPM
=PMBPS=PMLO=PMAUX= "1", MCKO= "1" and Master Mode. AVDD : 10mA (typ.), DVDD : 6mA (typ.)
AVDD : 10mA (typ.), DVDD : 4mA (typ.) at MCKO= "0" in Slave Mode

Note 19. PMMIC=PMADC=PMDAC=PMMO=PMHPL=PMHPR=PMVCM=PMPLL=PMXTL=PMBPM
=PMBPS=PMLO=PMAUX= "1", PMSPK= "0".

Note 20. PMMIC=PMADC=PMDAC=PMMO=PMSPK=PMVCM=PMPLL=PMXTL=PMBPM=PMBPS=PMLO
=PMAUX= "1", PMHPL=PMHPR= "0".

Note 21. All digital input pins are fixed to DVDD or DVSS.

| FILTER CHARACTERISTICS | | | | | | | |
|---|---------|--------|------|-------|-------|-------|-----|
| (Ta=-10 ~ 70°C; AVDD, DVDD, PVDD, HVDD=2.4 ~ 3.6V; fs=44.1kHz; DEM=OFF) | | | | | | | |
| Parameter | | Symbol | min | typ | max | Units | |
| ADC Digital Filter (Decimation LPF): | | | | | | | |
| Passband (Note 22) | ±0.1dB | PB | 0 | 20.0 | 17.4 | kHz | |
| | -1.0dB | | - | | - | kHz | |
| | -3.0dB | | - | | 21.1 | - | kHz |
| Stopband | | SB | 27.0 | | | kHz | |
| Passband Ripple | | PR | | | ±0.1 | dB | |
| Stopband Attenuation | | SA | 65 | | | dB | |
| Group Delay (Note 23) | | GD | | 17.0 | | 1/fs | |
| Group Delay Distortion | | ΔGD | | 0 | | μs | |
| ADC Digital Filter (HPF): | | | | | | | |
| Frequency Response (Note 22) | -3.0dB | FR | | 3.4 | | Hz | |
| | -0.5dB | | | 10 | | Hz | |
| | -0.1dB | | | 22 | | Hz | |
| DAC Digital Filter: | | | | | | | |
| Passband (Note 22) | ±0.01dB | PB | 0 | 22.05 | 20.0 | kHz | |
| | -6.0dB | | - | | - | kHz | |
| Stopband | | SB | 24.1 | | | kHz | |
| Passband Ripple | | PR | | | ±0.06 | dB | |
| Stopband Attenuation | | SA | 43 | | | dB | |
| Group Delay (Note 23) | | GD | | 16.8 | | 1/fs | |
| DAC Digital Filter + SCF: | | | | | | | |
| Frequency Response: 0 ~ 20.0kHz | | FR | | ±0.5 | | dB | |
| BOOST Filter: (Note 24) | | | | | | | |
| Frequency Response | MIN | 20Hz | FR | - | 5.74 | - | dB |
| | | 100Hz | | - | 2.92 | - | dB |
| | | 1kHz | | - | 0.0 | - | dB |
| | MID | 20Hz | FR | - | 5.94 | - | dB |
| | | 100Hz | | - | 4.71 | - | dB |
| | | 1kHz | | - | 0.14 | - | dB |
| | MAX | 20Hz | FR | - | 16.04 | - | dB |
| | | 100Hz | | - | 10.55 | - | dB |
| | | 1kHz | | - | 0.3 | - | dB |

Note 22. The passband and stopband frequencies scale with fs (system sampling rate).

For example, ADC is $PB=0.454*fs$ (@-1.0dB), DAC is $PB=0.454*fs$ (@-0.01dB).

Note 23. The calculated delay time caused by digital filtering. This time is from the input of analog signal to setting of the 16-bit data of both channels from the input register to the output register of the ADC. This time includes the group delay of the HPF. For the DAC, this time is from setting the 16-bit data of both channels from the input register to the output of analog signal.

Note 24. These frequency responses scale with fs. If a high-level and low frequency signal is input, the analog output clips to the full-scale.

| |
|---------------------------|
| DC CHARACTERISTICS |
|---------------------------|

(Ta=-10 ~ 70°C; AVDD, DVDD, PVDD, HVDD=2.4 ~ 3.6V)

| Parameter | Symbol | min | typ | Max | Units |
|---|--------|----------|-----|---------|-------|
| High-Level Input Voltage | VIH | 70%DVDD | - | - | V |
| Low-Level Input Voltage | VIL | - | - | 30%DVDD | V |
| Input Voltage at AC Coupling (Note 25) | VAC | 50%DVDD | - | - | V |
| High-Level Output Voltage (Iout=-200μA) | VOH | DVDD-0.2 | - | - | V |
| Low-Level Output Voltage (Except SDA pin: Iout=200μA) | VOL | - | - | 0.2 | V |
| (SDA pin: Iout= 3mA) | VOL | - | - | 0.4 | V |
| Input Leakage Current | Iin | - | - | ±10 | μA |

Note 25. When AC coupled capacitor is connected to MCKI pin.

| |
|----------------------------------|
| SWITCHING CHARACTERISTICS |
|----------------------------------|

(Ta=-10 ~ 70°C; AVDD, DVDD, PVDD, HVDD=2.4 ~ 3.6V; C₁=20pF)

| Parameter | Symbol | min | typ | max | Units | |
|---|---|---------|----------|--------|--------|-----|
| Master Clock Timing | | | | | | |
| Crystal Resonator | Frequency | 11.2896 | - | 12.288 | MHz | |
| External Clock | Frequency | fCLK | 1.792 | - | 12.288 | MHz |
| | Pulse Width Low | tCLKL | 0.4/fCLK | - | - | ns |
| | Pulse Width High | tCLKH | 0.4/fCLK | - | - | ns |
| | AC Pulse Width (Note 26) | tACW | 0.4/fCLK | - | - | ns |
| MCKO Output | Frequency | fMCK | 0.224 | - | 12.288 | MHz |
| | Duty Cycle : except fs=32kHz fs=32kHz at 256fs (Note 27) | dMCK | 40 | 50 | 60 | % |
| | | dMCK | - | 33 | - | % |
| LRCK Frequency | | | | | | |
| Frequency | fs | 7 | - | 48 | kHz | |
| Duty Cycle | Slave mode | Duty | 45 | - | 55 | % |
| | Master mode | Duty | - | 50 | - | % |
| Audio Interface Timing | | | | | | |
| Slave mode | | | | | | |
| BICK Period | tBCK | 312.5 | - | - | ns | |
| BICK Pulse Width Low | tBCKL | 130 | - | - | ns | |
| | tBCKH | 130 | - | - | ns | |
| LRCK Edge to BICK “↑” (Note 28) | tLRB | 50 | - | - | ns | |
| BICK “↑” to LRCK Edge (Note 28) | tBLR | 50 | - | - | ns | |
| LRCK to SDTO (MSB) (Except I ² S mode) | tLRS | - | - | 80 | ns | |
| BICK “↓” to SDTO | tBSD | - | - | 80 | ns | |
| SDTI Hold Time | tSDH | 50 | - | - | ns | |
| SDTI Setup Time | tSDS | 50 | - | - | ns | |
| Master mode | | | | | | |
| BICK Frequency | fBCK | - | 64fs | - | Hz | |
| BICK Duty | dBCK | - | 50 | - | % | |
| BICK “↓” to LRCK | tMBLR | -80 | - | 80 | ns | |
| BICK “↓” to SDTO | tBSD | -80 | - | 80 | ns | |
| SDTI Hold Time | tSDH | 50 | - | - | ns | |
| SDTI Setup Time | tSDS | 50 | - | - | ns | |

Note 26. Pulse width to ground level when MCKI is connected to a capacitor in series and a resistor is connected to ground. (Refer to Figure 4)

Note 27. PMPLL bit = “1”.

Note 28. BICK rising edge must not occur at the same time as LRCK edge.

| Parameter | Symbol | min | typ | max | Units |
|--|---------|------|------|-----|-------|
| Control Interface Timing (4-wire Serial mode): | | | | | |
| CCLK Period | tCCK | 200 | | | ns |
| CCLK Pulse Width Low | tCCKL | 80 | | | ns |
| Pulse Width High | tCCKH | 80 | | | ns |
| CDTI Setup Time | tCDS | 40 | | | ns |
| CDTI Hold Time | tCDH | 40 | | | ns |
| CSN "H" Time | tCSW | 150 | | | ns |
| CSN "↓" to CCLK "↑" | tCSS | 50 | | | ns |
| CCLK "↑" to CSN "↑" | tCSH | 50 | | | ns |
| CDTO Delay | tDCD | | | 50 | ns |
| CSN "↑" to CDTO Hi-Z | tCCZ | | | 70 | ns |
| Control Interface Timing (I²C Bus mode): | | | | | |
| SCL Clock Frequency | fSCL | - | | 100 | kHz |
| Bus Free Time Between Transmissions | tBUF | 4.7 | | - | μs |
| Start Condition Hold Time (prior to first clock pulse) | tHD:STA | 4.0 | | - | μs |
| Clock Low Time | tLOW | 4.7 | | - | μs |
| Clock High Time | tHIGH | 4.0 | | - | μs |
| Setup Time for Repeated Start Condition | tSU:STA | 4.7 | | - | μs |
| SDA Hold Time from SCL Falling (Note 29) | tHD:DAT | 0 | | - | μs |
| SDA Setup Time from SCL Rising | tSU:DAT | 0.25 | | - | μs |
| Rise Time of Both SDA and SCL Lines | tR | - | | 1.0 | μs |
| Fall Time of Both SDA and SCL Lines | tF | - | | 0.3 | μs |
| Setup Time for Stop Condition | tSU:STO | 4.0 | | - | μs |
| Pulse Width of Spike Noise Suppressed by Input Filter | tSP | 0 | | 50 | ns |
| Reset Timing | | | | | |
| PDN Pulse Width (Note 30) | tPD | 150 | | | ns |
| PMADC "↑" to SDTO valid (Note 31) | tPDV | | 2081 | | 1/fs |

Note 29. Data must be held long enough to bridge the 300ns-transition time of SCL.

Note 30. The AK4538 can be reset by the PDN pin = "L".

Note 31. This is the count of LRCK "↑" from the PMADC bit = "1".

Purchase of Asahi Kasei Microsystems Co., Ltd I²C components conveys a license under the Philips I²C patent to use the components in the I²C system, provided the system conform to the I²C specifications defined by Philips.

■ Timing Diagram

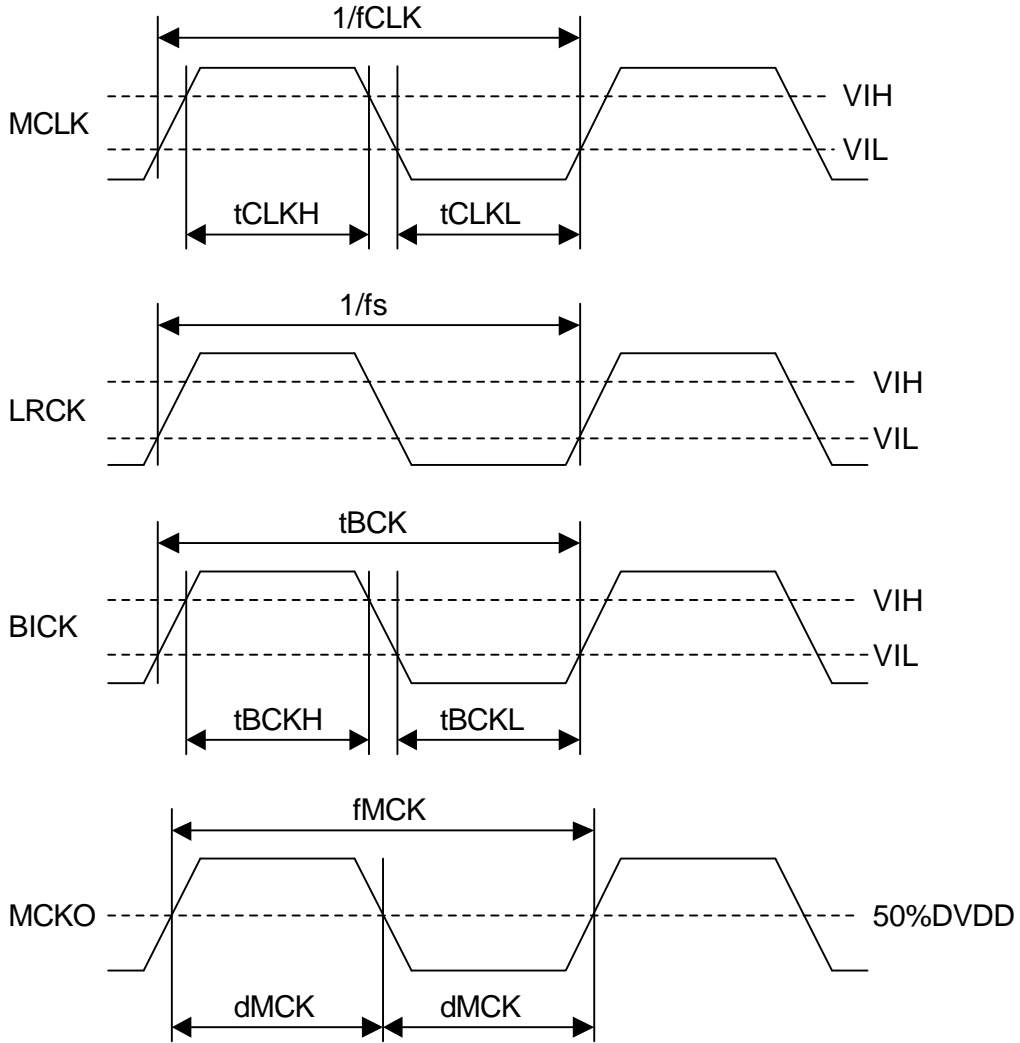

Figure 3. Clock Timing

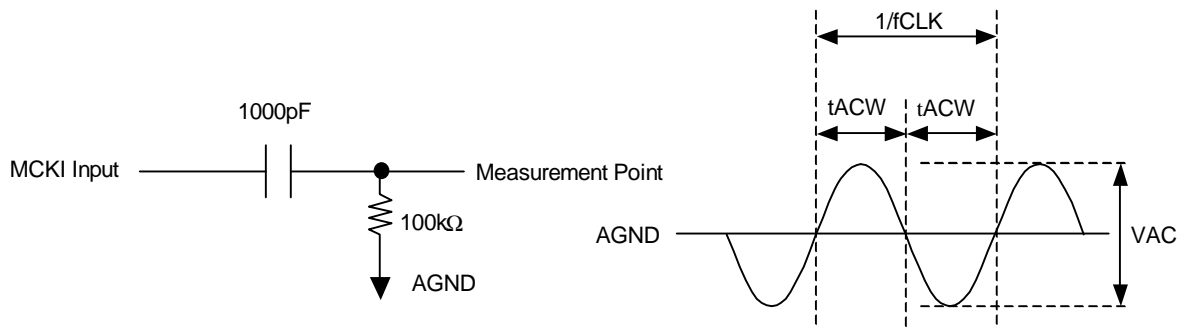

Figure 4. MCKI AC Coupling Timing

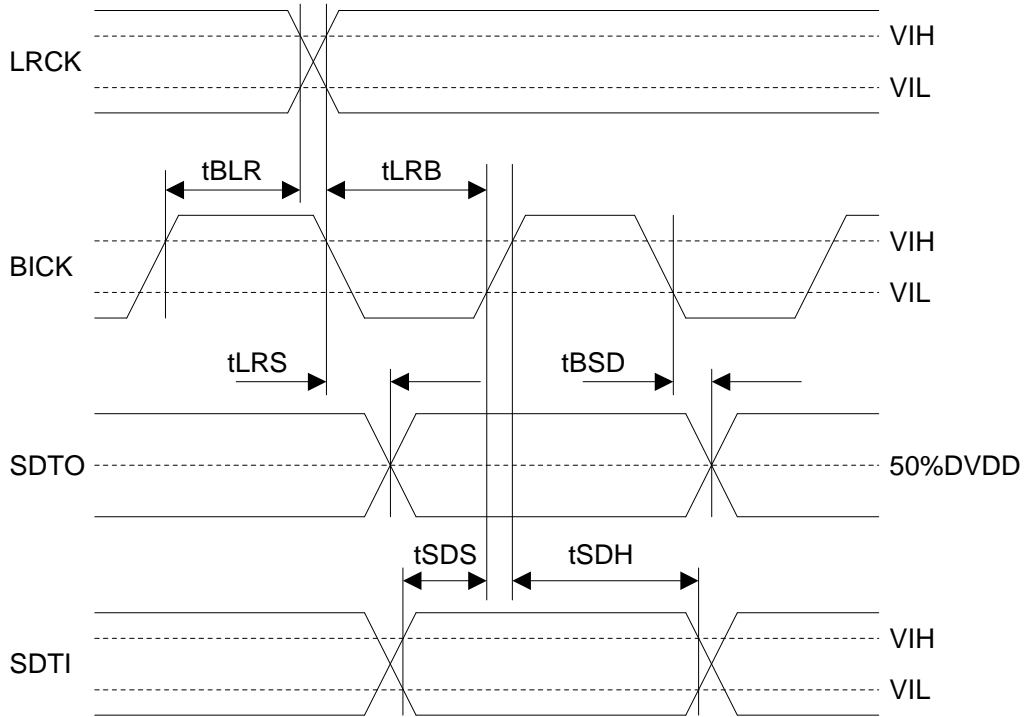

Figure 5. Audio Interface Timing (Slave mode)

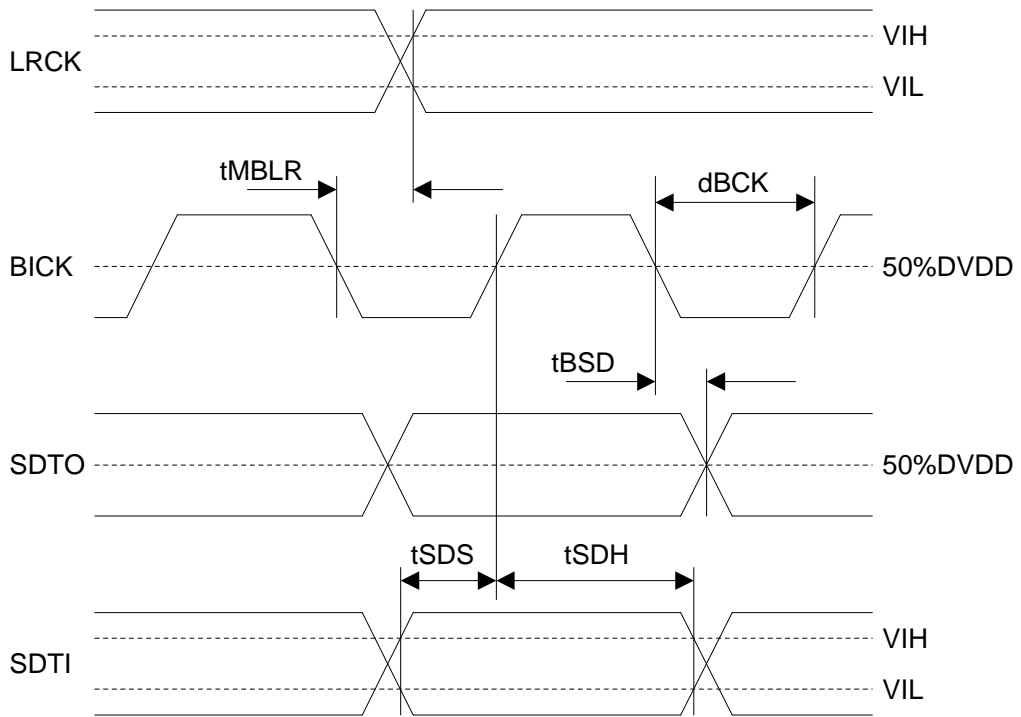

Figure 6. Audio Interface Timing (Master mode)

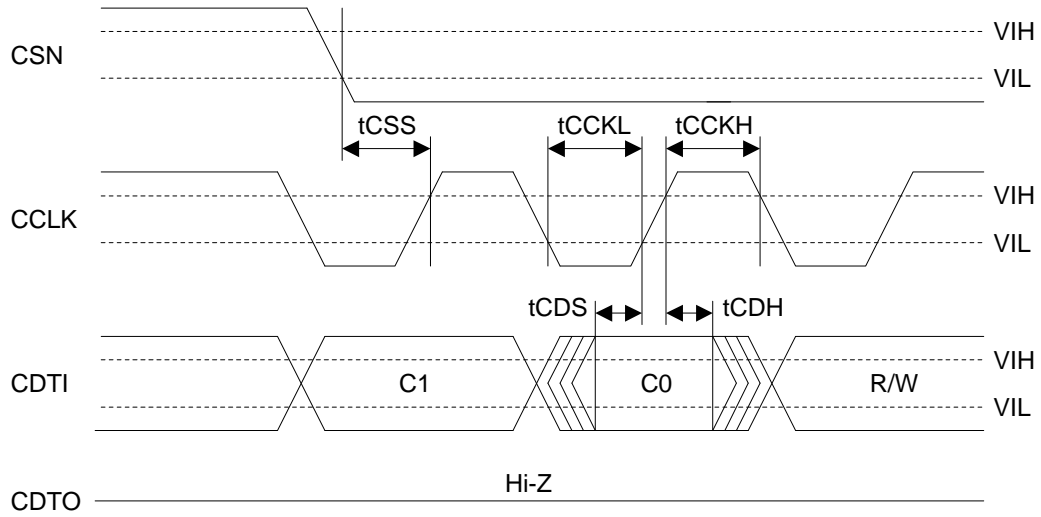

Figure 7. WRITE/READ Command Input Timing

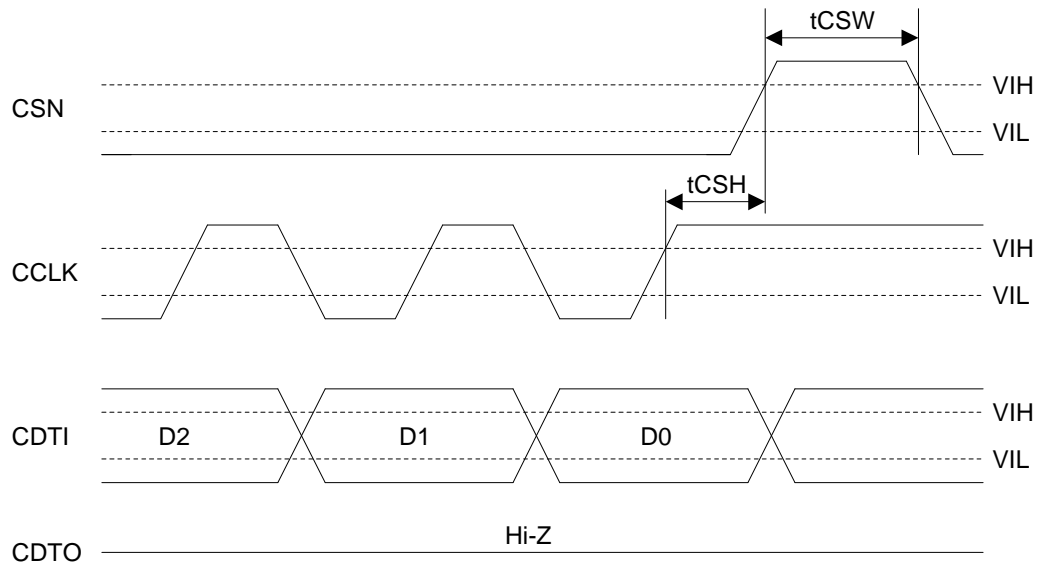

Figure 8. WRITE Data Input Timing

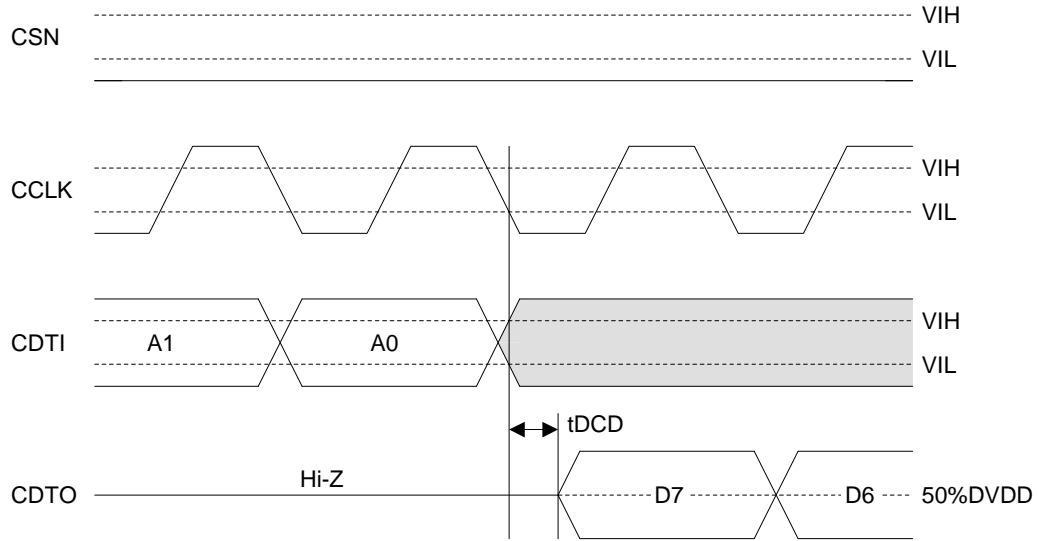

Figure 9. READ Data Output Timing 1

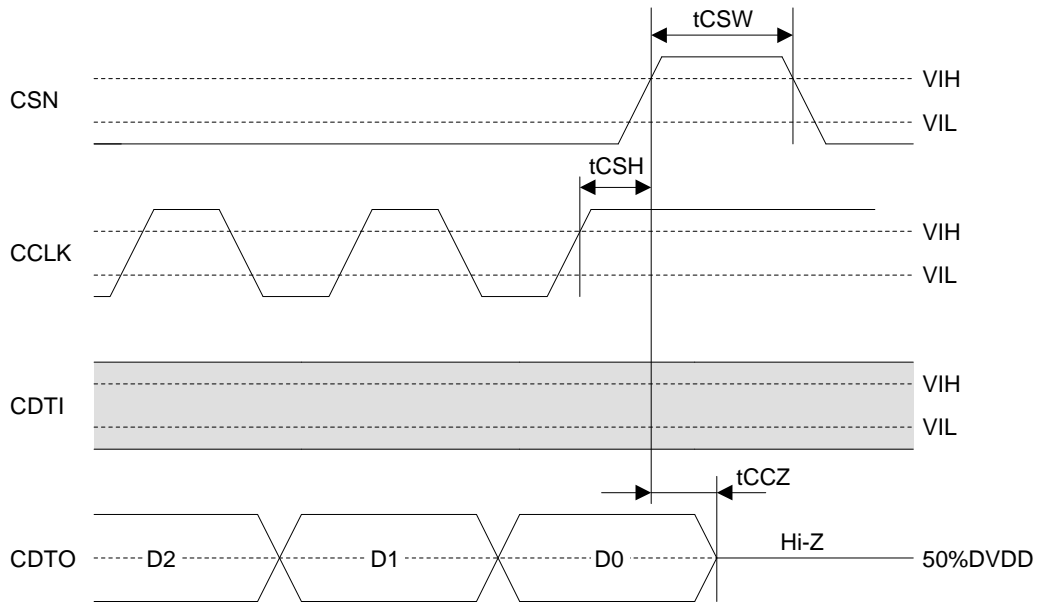

Figure 10. READ Data Output Timing 2

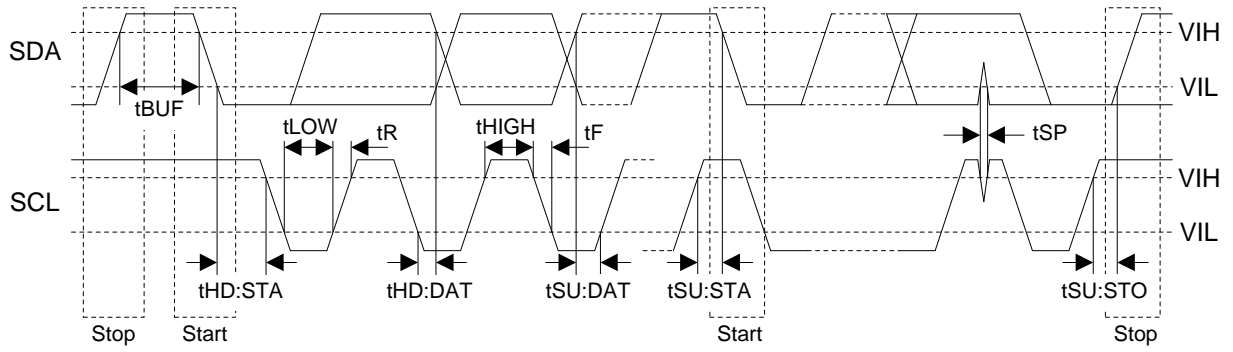

Figure 11. I²C Bus Mode Timing

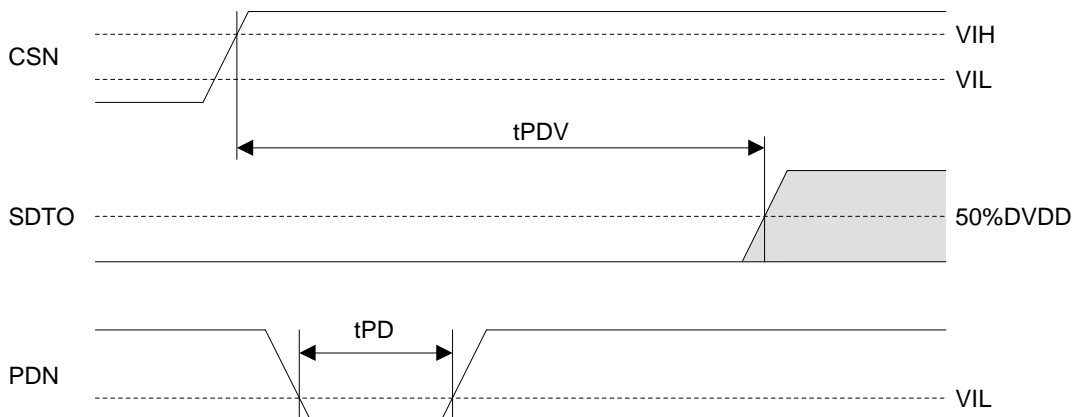

Figure 12. Power Down & Reset Timing

OPERATION OVERVIEW

■ **Master Clock Source**

The AK4538 requires a master clock (MCLK). This master clock is input to the AK4538 by connecting a X'tal oscillator to XTI and XTO pins or by inputting an external CMOS-level clock to the XTI pin or by inputting an external clock that is greater than 50% of the DVDD level to the XTI pin through a capacitor.

When using a X'tal oscillator, there should be capacitors between XTI/XTO pins and DVSS. When using an external clock, there are two choices: direct, where an external clock is input directly to the XTI pin and indirect, where the external clock is input through a capacitor.

| Master Clock | Status | PMXTL bit | MCKPD bit |
|---|--------------------------------|-----------|-----------|
| X'tal Oscillator (Figure 13) | Oscillator ON | 1 | 0 |
| | Oscillator OFF | 0 | 1 |
| External Clock Direct Input (Figure 14) | Clock is input to MCKI pin. | 0 | 0 |
| | MCKI pin is fixed to "L". | 0 | 0/1 |
| | MCKI pin is fixed to "H". | 0 | 0 |
| | MCKI pin is Hi-Z. | 0 | 1 |
| AC Coupling Input (Figure 15) | Clock is input to MCKI pin. | 1 | 0 |
| | Clock isn't input to MCKI pin. | 0 | 1 |

Table 1. Master Clock Status by PMXTL bit and MCKPD bit

(1) X'tal Oscillator

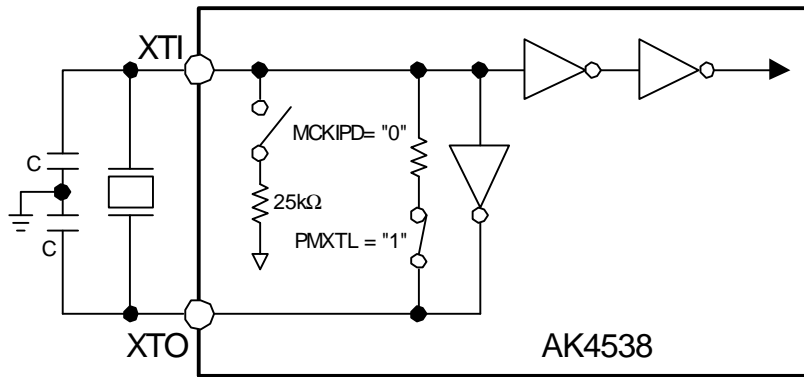

Figure 13. X'tal mode

- Note: The capacitor values depend on the X'tal oscillator used. (C : typ. 10 ~ 30pF)

(2) External Clock Direct Input

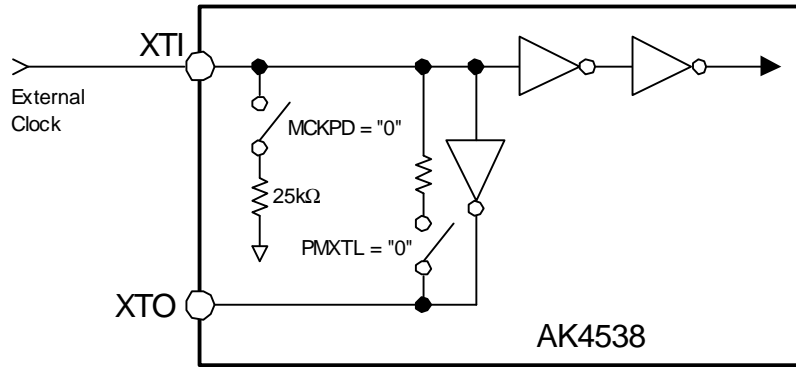

Figure 14. External Clock mode (Input : CMOS Level)
- Note: This clock level must not exceed DVDD level.

(3) AC Coupling Input

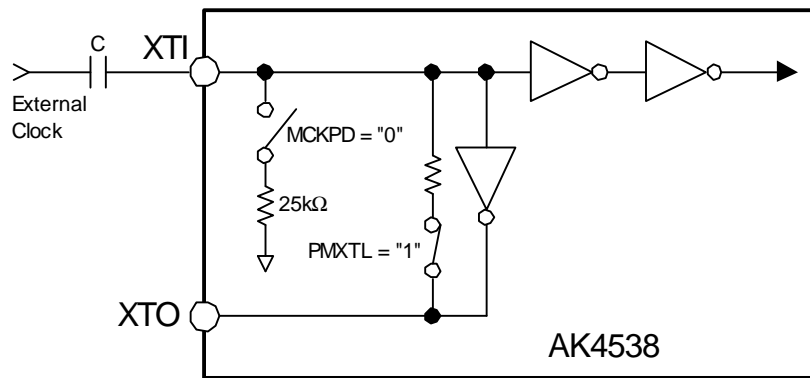

Figure 15. External Clock mode (Input : $\geq 50\%DVDD$)
- Note: This clock level must not exceed DVDD level. (C : 0.1 μ F)

■ System Clock

(1) PLL Mode (PMPLL bit = “1”)

A fully integrated analog phase locked loop (PLL) generates a clock that is selected by the PLL1-0 and FS2-0 bits (see Table 2 and Table 3). The frequency of the MCKO output is selectable via the PS1-0 bits registers as defined in Table 4 and the MCKO output enable is controlled by the MCKO bit. **If PS1-0 bits are changed before LRCK is input, MCKO is not output. PS1-0 bits should be changed after LRCK is input in slave mode.**

The PLL should be powered-up after the X'tal oscillator becomes stable or external master clock is inputted. **If X'tal and PLL are powered-up at the same time or PLL is powered-up before external master clock is inputted, the PLL does not start.** It takes X'tal oscillator 20ms(typ) to be stable after PMXTL bit= “1”. The PLL needs 40ms lock time, whenever the sampling frequency changes or the PLL is powered-up (PMPLL bit= “0” → “1”).

If the sampling frequency is changed and the PLL goes to unlock state when the DAC is operated(PMDAC bit= “1”), the DAC data should be soft-muted or “0”. In case of the ADC(PMADC bit = “1”), the ADC data acquired during the frequency change may be erroneous and therefore should not be used.

LRCK and BICK are output from the AK4538 in master mode. When the clock input to MCKI pin stops during normal operation (PMPLL bit = “1”), the internal PLL continues to oscillate (a few MHz), and LRCK and BICK outputs go to “L” (see Table 5).

In slave mode, the LRCK input should be synchronized with MCKO. The master clock (MCKI) should be synchronized with sampling clock (LRCK). The phase between these clocks does not matter. LRCK and BICK must be present whenever the AK4538 is operating (PMADC bit = “1” or PMDAC bit = “1”). If these clocks are not provided, the AK4538 may draw excess current due to its use of internal dynamically refreshed logic. If the external clocks are not present, place the AK4538 in power-down mode (PMADC bit = PMDAC bit = “0”).

| Mode | PLL1 | PLL0 | MCKI | |
|------|------|------|------------|---------|
| 0 | 0 | 0 | 12.288MHz | Default |
| 1 | 0 | 1 | 11.2896MHz | |
| 2 | 1 | 0 | 12MHz | |
| 3 | 1 | 1 | N/A | |

Table 2. MCKI Input Frequency (PLL Mode)

| FS2 | FS1 | FS0 | Sampling Frequency | |
|-----|-----|-----|--------------------|---------|
| 0 | 0 | 0 | 44.1kHz | Default |
| 0 | 0 | 1 | 22.05kHz | |
| 0 | 1 | 0 | 11.025kHz | |
| 0 | 1 | 1 | 48kHz | |
| 1 | 0 | 0 | 32kHz | |
| 1 | 0 | 1 | 24kHz | |
| 1 | 1 | 0 | 16kHz | |
| 1 | 1 | 1 | 8kHz | |

Table 3. Sampling Frequency (PLL Mode)

| Mode | PS1 | PS0 | MCKO | |
|------|-----|-----|-------|---------|
| 0 | 0 | 0 | 256fs | Default |
| 1 | 0 | 1 | 128fs | |
| 2 | 1 | 0 | 64fs | |
| 3 | 1 | 1 | 32fs | |

Table 4. MCKO Frequency (PLL Mode, MCKO bit = “1”)

| | Master Mode (M/S pin = "H") | | |
|----------|--|------------------|---|
| | Power up | Power down | PLL Unlock |
| MCKI pin | Frequency set by PLL1-0 bits (Refer to Table 2) | Refer to Table 1 | Frequency set by PLL1-0 bits (Refer to Table 2) |
| MCKO pin | MCKO bit = "0" : "L" MCKO bit = "1" : Output | "L" | MCKO bit = "0" : "L" MCKO bit = "1" : Unsettling |
| BICK pin | BF bit = "0" : 64fs Output BF bit = "1" : 32fs Output | "L" | "L" |
| LRCK pin | Output | "L" | "L" |

Table 5. Clock Operation at Master Mode (PLL Mode)

| | Slave Mode (M/S pin = "L") | | |
|----------|---|--------------------------------|---|
| | Power up | Power down | PLL Unlock |
| MCKI pin | Frequency set by PLL1-0 bits (Refer to Table 2) | Refer to Table 1 | Frequency set by PLL1-0 bits (Refer to Table 2) |
| MCKO pin | MCKO bit = "0" : "L" MCKO bit = "1" : Output | "L" | MCKO bit = "0" : "L" MCKO bit = "1" : Unsettling |
| BICK pin | Input | Fixed to "L" or "H" externally | Input |
| LRCK pin | Input | Fixed to "L" or "H" externally | Input |

Table 6. Clock Operation at Slave Mode (PLL Mode)

(2) External mode (PMPLL bit = "0")

When the PMPLL bit = "0", the AK4538 works in external clock mode. The MCKO pin outputs a buffered clock of MCKI input.

For example, when MCKI = 256fs, the sampling frequency is changeable from 7kHz to 48kHz (Table 7). The MCKO bit controls MCKO output enable. The frequency of MCKO is selectable via register the PS1-0 bits as defined in Table 8. The master clock frequency should be changed only when both the PMADC and PMDAC bits = "0".

LRCK and BICK are output from the AK4538 in master mode. The clock to the MCKI pin must not stop during normal operation (PMPLL bit = "1"). If this clock is not provided, the AK4538 may draw excess current due to its use of internal dynamically refreshed logic. If the external clocks are not present, place the AK4538 in power-down mode (PMADC bit = PMDAC bit = "0").

MCKI, BICK and LRCK clocks are required in slave mode. The master clock (MCKI) should be synchronized with sampling clock (LRCK). The phase between these clocks does not matter. LRCK and BICK should always be present whenever the AK4538 is in normal operation (PMADC bit = "1" or PMDAC bit = "1"). If these clocks are not provided, the AK4538 may draw excess current due to its use of internal dynamically refreshed logic. If the external clocks are not present, place the AK4538 in power-down mode (PMADC bit = PMDAC bit = "0").

| Mode | FS1 | FS0 | Sampling Frequency (fs) | MCKI | Default |
|------|-----|-----|-------------------------|--------|---------|
| 0 | 0 | 0 | 7kHz ~ 48kHz | 256fs | |
| 1 | 0 | 1 | 7kHz ~ 24kHz | 512fs | |
| 2 | 1 | 0 | 7kHz ~ 12kHz | 1024fs | |
| 3 | 1 | 1 | 7kHz ~ 48kHz | 256fs | |

Table 7. Sampling Frequency Select (EXT Mode)

| Mode | PS1 | PS0 | MCKO |
|------|-----|-----|-------|
| 0 | 0 | 0 | 256fs |
| 1 | 0 | 1 | 128fs |
| 2 | 1 | 0 | 64fs |
| 3 | 1 | 1 | 32fs |

Default

Table 8. MCKO Frequency (EXT Mode, MCKO bit = "1")

| | Master Mode (M/S pin = "H") | |
|----------|--|------------|
| | Power up | Power down |
| MCKO pin | MCKO bit = "0" : "L" MCKO bit = "1" : Output | "L" |
| BICK pin | BF bit = "0" : 64fs Output BF bit = "1" : 32fs Output | "L" |
| LRCK pin | Output | "L" |

Table 9. Clock Operation at Master Mode (EXT Mode)

| | Slave Mode (M/S pin = "L") | |
|----------|---|--------------------------------|
| | Power up | Power down |
| MCKO pin | MCKO bit = "0" : "L" MCKO bit = "1" : Output | "L" |
| BICK pin | Input | Fixed to "L" or "H" externally |
| LRCK pin | Input | Fixed to "L" or "H" externally |

Table 10. Clock Operation at Slave Mode (EXT Mode)

The S/N of the DAC at low sampling frequencies is worse than at high sampling frequencies due to out-of-band noise. When the out-of-band noise can be improved by using higher frequency of the master clock. The S/N of the DAC output through Headphone amp at fs=8kHz is shown in Table 11.

| MCLK | S/N (fs=8kHz, A-weighted) |
|--------|---------------------------|
| 256fs | 84dB |
| 512fs | 88dB |
| 1024fs | 88dB |

Table 11. Relationship between MCLK and S/N of HP-AMP

■ Master Mode/Slave Mode

The M/S pin selects either master or slave modes. M/S pin = "H" selects master mode and "L" selects slave mode. The AK4538 outputs MCKO, BICK and LRCK in master mode. The AK4538 outputs only MCKO in slave mode, while BICK and LRCK must be input separately.

| | MCKO | BICK / LRCK |
|-------------|---------------|--------------------------------|
| Slave Mode | MCKO = Output | BICK = Input LRCK = Input |
| Master Mode | MCKO = Output | BICK = Output LRCK = Output |

Table 12. Master mode/Slave mode

■ System Reset

Upon power-up, reset the AK4538 by bringing the PDN pin = “L”. This ensures that all internal registers reset to their initial values.

The ADC enters an initialization cycle that starts when the PMADC bit is changed from “0” to “1”. The initialization cycle time is 2081/fs, or 47.2ms@fs=44.1kHz. During the initialization cycle, the ADC digital data outputs of both channels are forced to a 2’s complement, “0”. The ADC output reflects the analog input signal after the initialization cycle is complete. The DAC does not require an initialization cycle.

■ Audio Interface Format

Three types of data formats are available and are selected by setting the DIF1-0 bits. In all modes, the serial data is MSB first, 2’s complement format. The SDTO is clocked out on the falling edge of BICK and the SDTI is latched on the rising edge. All data formats can be used in both master and slave modes. LRCK and BICK are output from AK4538 in master mode, but must be input to AK4538 in slave mode. If 16-bit data that ADC outputs is converted to 8-bit data by removing LSB 8-bit, -1 at 16bit data is converted to -1 at 8-bit data. And when the DAC playbacks this 8-bit data, -1 at 8-bit data will be converted to -256 at 16-bit data and this is a large offset. This offset can be removed by adding the offset of 128 to 16-bit data before converting to 8-bit data.

| Mode | DIF1 | DIF0 | SDTO (ADC) | SDTI (DAC) | BICK | Figure |
|------|------|------|------------------|------------------|--------|-----------|
| 0 | 0 | 0 | MSB justified | LSB justified | ≥ 32fs | Figure 16 |
| 1 | 0 | 1 | MSB justified | MSB justified | ≥ 32fs | Figure 17 |
| 2 | 1 | 0 | I ² S | I ² S | ≥ 32fs | Figure 18 |
| 3 | 1 | 1 | N/A | N/A | N/A | - |

Default

Table 13. Audio Interface Format

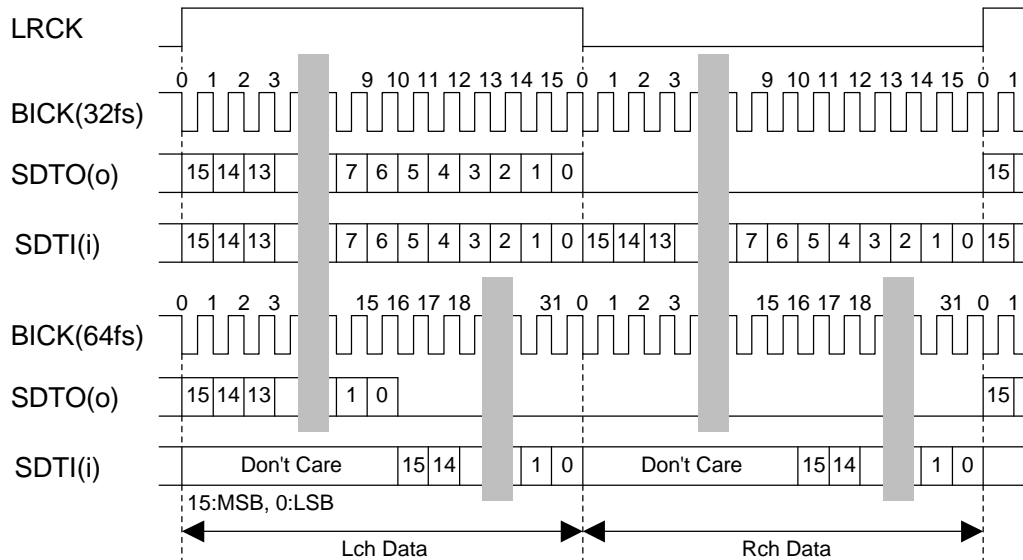

Figure 16. Mode 0 Timing

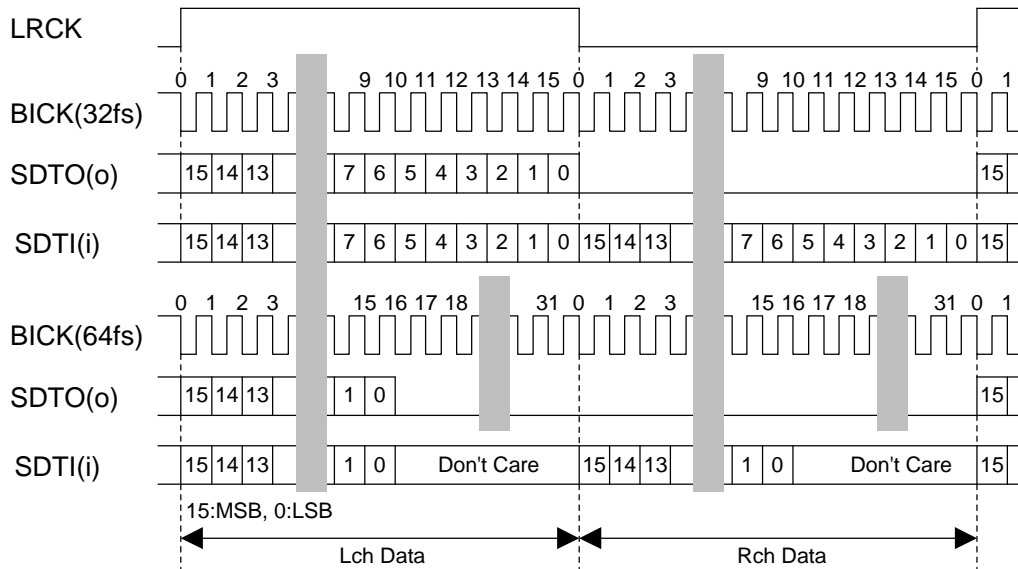

Figure 17. Mode 1 Timing

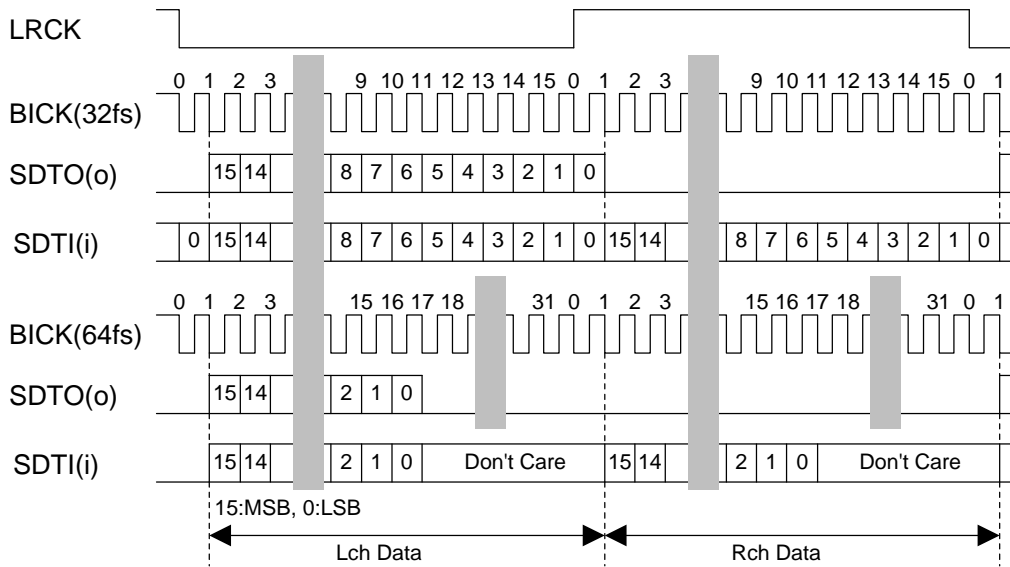

Figure 18. Mode 2 Timing

■ Digital High Pass Filter

The ADC has a digital high pass filter for DC offset cancellation. The cut-off frequency of the HPF is 3.4Hz (@fs=44.1kHz) and scales with sampling rate (fs).

■ MIC Input

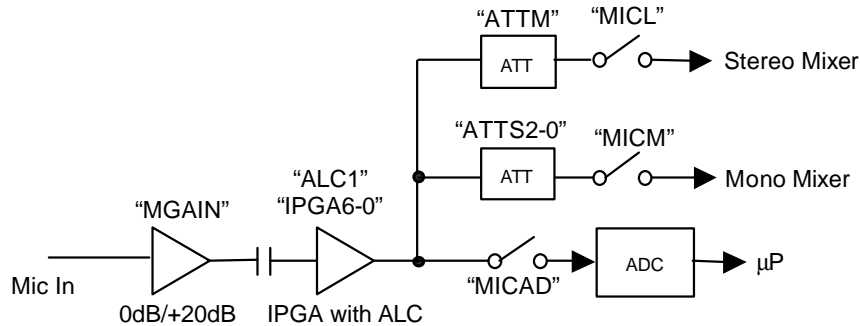

Figure 19. Microphone Input

The AK4538 has the following functions for Mic Input.

- (1) 1st MIC Amplifier of 20dB gain that can be selected on/off by “MGAIN” bit.
- (2) 2nd Amplifier that has PGA with ALC. This volume is controlled by “IPGA6-0” bit as Table 14.
While ALC is working, Master Clock must be present.
When Master Clock isn’t provided or PMMIC= “0”, it is invalid to write to “IPGA6-0”.
- (3) Attenuator for stereo mixer. This volume is controlled by “ATTS2-0” bit as Table 15.
- (4) Attenuator for mono mixer. This attenuator level is 4dB and this ON/OFF is controlled by “ATTM” bit.

| IPGA6-0 | GAIN (dB) | STEP |
|---------|-----------|-------|
| 47H | +27.5 | 0.5dB |
| 46H | +27.0 | |
| 45H | +26.5 | |
| : | : | |
| 36H | +19.0 | |
| : | : | |
| 10H | +0.0 | |
| : | : | |
| 06H | -5.0 | |
| 05H | -5.5 | |
| 04H | -6.0 | |
| 03H | -6.5 | |
| 02H | -7.0 | |
| 01H | -7.5 | |
| 00H | -8.0 | |

Default

Table 14. Microphone Input Gain Setting

| ATTS2-0 | Attenuation |
|---------|-------------|
| 7H | -6dB |
| 6H | -9dB |
| 5H | -12dB |
| 4H | -15dB |
| 3H | -18dB |
| 2H | -21dB |
| 1H | -24dB |
| 0H | -27dB |

Default

Table 15. Attenuator Table

■ MIC Gain Amplifier

AK4538 has a Gain Amplifier for Microphone input. This gain is 0dB or +20dB, selected by the MGAIN bit. The typical input impedance is 30kΩ.

| MGAIN bit | Input Gain |
|-----------|------------|
| 0 | 0dB |
| 1 | +20dB |

Default

Table 16. Input Gain

■ MIC Power

The MPI and MPE pins supply power for the Microphone. These output voltages are $0.75 \times AVDD$ (typ) and the maximum output current is 1.25mA. MPWRI/MPWRE bit can control output from MPI and MPO pin.

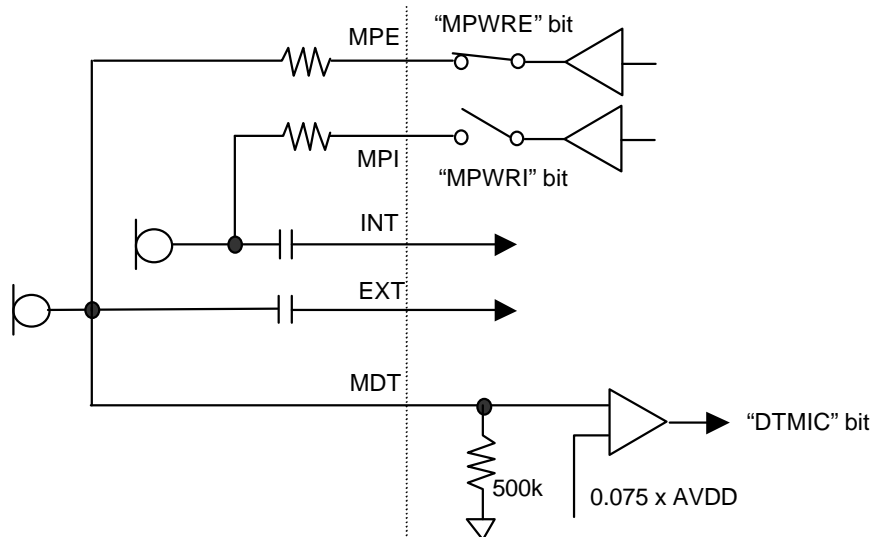

Figure 20. Microphone Power Supply

■ MIC Detection Function

The AK4538 includes the detection function of microphone.

Example of the detection of external microphone.

- (1) MPWRE= "1".
- (2) MPE drives external microphone.
- (3) DTMIC bit is set by Table 17.

| Input Level of DTM | DTMIC | External microphone |
|--------------------------|-------|---------------------|
| $\geq 0.075 \times AVDD$ | 1 | Connect |
| $< 0.050 \times AVDD$ | 0 | Disconnect |

Table 17. Microphone detection result

■ ALC1 Operation

[1] ALC1 Limiter Operation

When the ALC1 limiter is enabled, and either Lch or Rch exceed the ALC1 limiter detection level (LMTH), the IPGA value is attenuated by the amount defined in the ALC1 limiter ATT step (LMAT1-0 bits) automatically.

When the ZELM bit = "1", the timeout period is set by the LTM1-0 bits. The operation for attenuation is done continuously until the input signal level becomes LMTH or less. If the ALC1 bit does not change into "0" after completing the attenuation, the attenuation operation repeats until the input signal level equals or exceeds LMTH.

When the ZELM bit = "0", the timeout period is set by the ZTM1-0 bits. This enables the zero-crossing attenuation function so that the IPGA value is attenuated at the zero-detect points of the waveform.

[2] ALC1 Recovery Operation

The ALC recovery refers to the amount of time that the AK4538 will allow a signal to exceed a predetermined limiting value prior to enabling the limiting function. The ALC1 recovery operation uses the WTM1-0 bits to define the wait period used after completing an ALC1 limiter operation. If the input signal does not exceed the "ALC1 Recovery Waiting Counter Reset Level", the ALC1 recovery operation starts. The IPGA value increases automatically during this operation up to the reference level (REF6-0 bits). The ALC1 recovery operation is done at a period set by the WTM1-0 bits. Zero crossing is detected during WTM1-0, the ALC1 recovery operation waits WTM1-0 period and the next recovery operation starts.

During the ALC1 recovery operation, when input signal level exceeds the ALC1 limiter detection level (LMTH), the ALC1 recovery operation changes immediately into an ALC1 limiter operation.

In the case of "(Recovery waiting counter reset level) \leq Input Signal < Limiter detection level" during the ALC1 recovery operation, the wait timer for the ALC1 recovery operation is reset. Therefore, in the case of "(Recovery waiting counter reset level) > Input Signal", the wait timer for the ALC1 recovery operation starts.

The ALC1 operation corresponds to the impulse noise. When the impulse noise is input, the ALC1 recovery operation becomes faster than a normal recovery operation.

[3] ALC1 Operation OFF (ALC1 bit = "0")

The ZTM1-0 bits set zero crossing timeout period. When the control register is written from the μ P, the zero crossing counter is reset and its counter starts. When the signal detects zero crossing or zero crossing timeout, the written value from the μ P becomes valid.

[4] Example of ALC1 Operation

The following registers should not be changed during the ALC1 operation.

- **LTM1-0, LMTH, LMAT1-0, WTM1-0, ZTM1-0, RATT, REF6-0, ZELM bits**

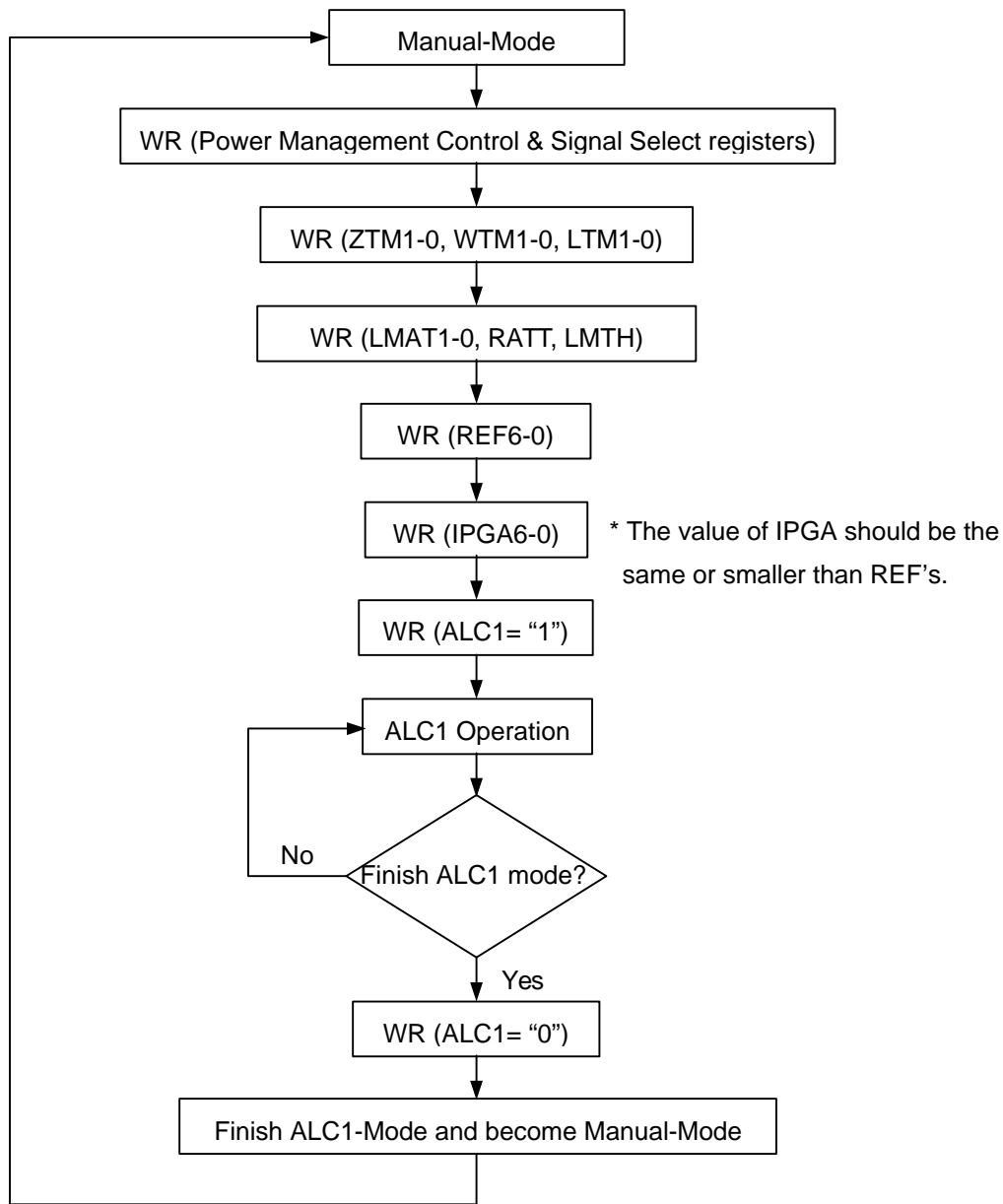

Note: WR: Write, RD: Read

Figure 21. Registers set-up sequence at ALC1 operation

■ **De-emphasis Filter**

The AK4538 includes the digital de-emphasis filter ($t_c = 50/15\mu s$) by IIR filter. Setting the DEM1-0 bits enables the de-emphasis filter.

| DEM1 | DEM0 | Mode |
|------|------|---------|
| 0 | 0 | 44.1kHz |
| 0 | 1 | OFF |
| 1 | 0 | 48kHz |
| 1 | 1 | 32kHz |

Default

Table 18. De-emphasis Control

■ **Bass Boost Function**

The BST1-0 bits control the amount of low frequency boost applied to the DAC output signal. If the BST1-0 bits are set to “10” (MID Level), use a 47 μF capacitor for AC-coupling. If the boosted signal exceeds full scale, the analog output clips to the full scale. Figure 22 shows the boost frequency response at -20dB signal input.

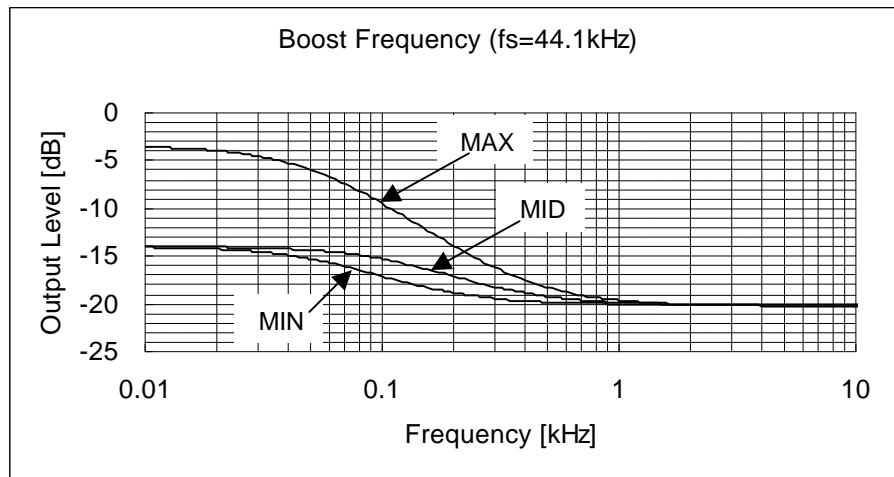

Figure 22. Boost Frequency (fs=44.1kHz)

| BST1 | BST0 | Mode |
|------|------|------|
| 0 | 0 | OFF |
| 0 | 1 | MIN |
| 1 | 0 | MID |
| 1 | 1 | MAX |

Default

Table 19. Low Frequency Boost Control

■ Digital Attenuator

The AK4538 has a channel-independent digital attenuator (256 levels, 0.5dB step, Mute). The attenuation level of each channel can be set by the ATTL/R7-0 bits (Table 20). When the DATTC bit = “1”, the ATTL7-0 bits control both Lch and Rch attenuation levels. When the DATTC bit = “0”, the ATTL7-0 bits control Lch level and ATTR7-0 bits control Rch level. This attenuator has a soft transition function. It takes 1061/fs from 00H to FFH.

| ATTL/R7-0 | Attenuation |
|-----------|-------------|
| 00H | 0dB |
| 01H | -0.5dB |
| 02H | -1.0dB |
| 03H | -1.5dB |
| : | : |
| : | : |
| FDH | -126.5dB |
| FEH | -127.0dB |
| FFH | MUTE (-∞) |

Table 20. DATT Code Table

■ Soft Mute

Soft mute operation is performed in the digital domain. When the SMUTE bit goes to a “1”, the output signal is attenuated by -∞ (“0”) during the cycle set by the TM1-0 bits. When the SMUTE bit is returned to “0”, the mute is cancelled and the output attenuation gradually changes to 0dB during the cycle set by the TM1-0 bits. If the soft mute is cancelled within the cycle set by the TM1-0 bits after starting the operation, the attenuation is discontinued and returned to 0dB. The soft mute is effective for changing the signal source without stopping the signal transmission.

The soft mute function is independent of output volume and cascade connected between both functions.

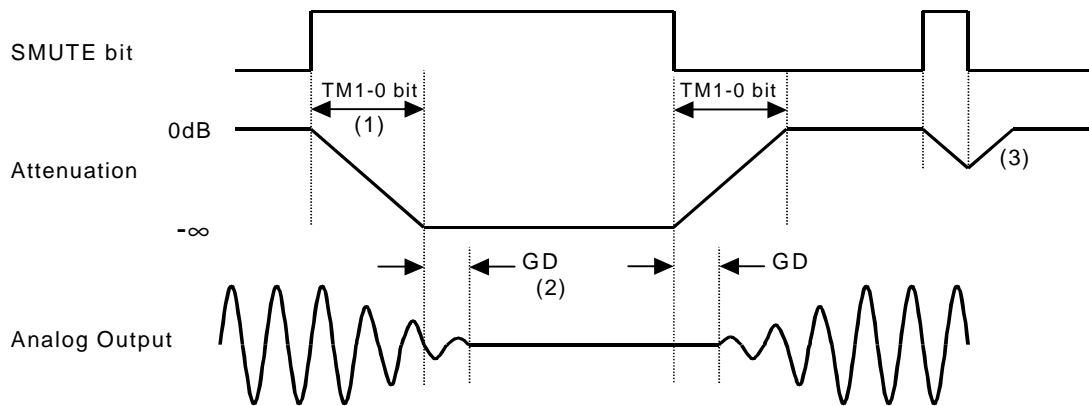

Figure 23. Soft Mute Function

NOTE:

- (1) The output signal is attenuated until -∞ (“0”) by the cycle set by the TM1-0 bits.
- (2) Analog output corresponding to digital input has the group delay (GD).
- (3) If the soft mute is cancelled within the cycle of setting the TM1-0 bits, the attenuation is discontinued and returned to 0dB(the set value).

■ AUX Input

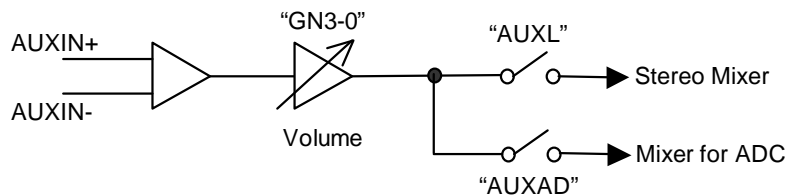

Figure 24. AUX Input

AUX input is differential input. The AK4538 has a volume for AUX Input. This Volume is controlled by GN3-0 bits as shown in Table 21. The AK4538 register control for GN3-0 does not offer any de-clicking function at volume setting change.

| GN3-0 | GAIN (dB) | |
|-------|-----------|---------|
| FH | +24.0 | |
| EH | +21.0 | |
| DH | +18.0 | |
| : | : | |
| 7H | +0.0 | Default |
| : | : | |
| 2H | -15.0 | |
| 1H | -18.0 | |
| 0H | -21.0 | |

Table 21. AUX Input Gain Setting

■ BEEP Input

When the BMBPS bit is set to “1”, the stereo beep input is powered up. And when the BPSHP bit is set to “1”, the input signals from the BEEPL and BEEPR pins are mixed to Headphone outputs. When the BPSSP bit is set to “1”, the signal of $(BEEPL + BEEPR)/2$ is input to Speaker-amp. When the BMBPM bit is set to “1”, mono beep input is powered up. And when the BPMHP bit is set to “1”, the input signal from the BEEPM pin to Headphone-amp. When the BPMSP bit is set to “1”, the signal from the BEEPM pin is input to Speaker output. The external resistors R_i adjust the signal level of each BEEP input that are mixed to Headphone and Speaker outputs.

The signal from the BEEPM pin is mixed to the Headphone-amp through a -20dB gain stage. The signal from the BEEPM pin is mixed to the Speaker-amp without gain. The internal feedback resistance is $20\text{k} \pm 30\% \Omega$.

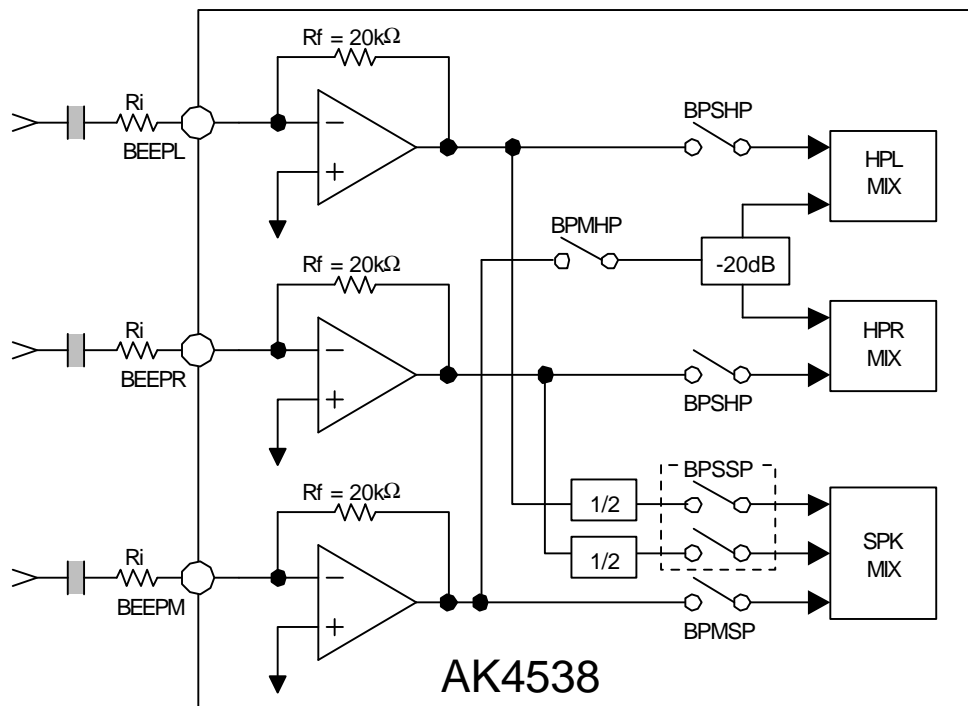

Figure 25. Block Diagram of BEEP pins

■ Headphone Output

Power supply voltage for the Headphone-amp is supplied from the HVDD pin and centered on the HVDD/2 voltage. The Headphone output load resistance is min.20Ω. When the HPL and HPR bits are “1”, output signals are muted and the HPL and HPR pins output HVDD/2 voltage. When the HPL and HPR bits are “0”, the Headphone-amps are in normal operation. When the PMHPL and PMHPR bits are “0”, the Headphone-amp is powered down and the outputs (HPL and HPR pins) go to “L” (HVSS). A capacitor between the MUTET pin and ground reduces pop noise at power-up.

[Example] : A capacitor between the MUTET pin and ground = 1.0μF, a capacitor between the HPL (HPR) pin and Headphone = 47μF

Time constant of rise time: $\tau_r = 100\text{ms}$, Time constant of fall time: $\tau_f = 188\text{ms}$

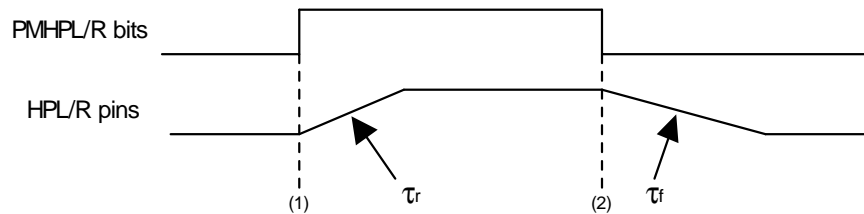

Figure 26. Power-up/Power-down Timing for Headphone-amp

Note: The HPL and HPR bits should be kept to “0” during power-up.

(1) PMHPL and PMHPR bits = “1”

Headphone-amp is powered up. Common voltage of Headphone-amp is rising. This rise time depends on the capacitor value connected with the MUTET pin. The time constant is $\tau_r = 100k \times C$ when the capacitor value on MUTET pin is “C”.

(2) PMHPL and PMHPR bits = “0”

Headphone-amp is powered down. Common voltage is falling. This fall time depends on the internal resistor and the capacitor value of HPL/R pins. The time constant is $\tau_f = 2k \times (2 \times C)$ when the capacitor value on HPL(HPR) pin is “C”. If the power supply is powered off or Headphone-Amp is powered-up again before the common voltage goes to GND, some POP noise occurs. It takes 5times of τ_f that the common voltage goes to GND.

The cut-off frequency of Headphone-amp output depends on the external resistor and capacitor used. Table 18 shows the cut off frequency and the output power for various resistor/capacitor combinations. The headphone impedance R_L is 16Ω. Output powers are shown at HVDD = 2.7, 3.0 and 3.3V. The output voltage of headphone is 0.6 x AVDD (Vpp). When an external resistor R is smaller than 12Ω, put an oscillation prevention circuit (0.22μF+10Ω) because it has the possibility that Headphone-amp oscillates.

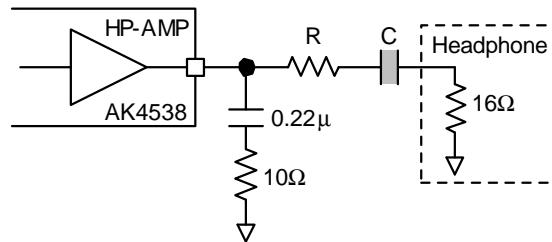

Figure 27. External Circuit Example of Headphone

| R [Ω] | C [μF] | fc [Hz] BOOST=OFF | fc [Hz] BOOST=MID | Output Power [mW] | | |
|-------|--------|----------------------|----------------------|-------------------|------|------|
| | | | | 2.7V | 3.0V | 3.3V |
| 6.8 | 47 | 148.5 | 60 | 10.1 | 12.5 | 15.0 |
| 16 | 47 | 105.8 | 43 | 5.1 | 6.3 | 7.7 |
| 6.8 | 100 | 69.8 | 26 | 10.1 | 12.5 | 15.0 |
| 16 | 100 | 49.7 | 20 | 5.1 | 6.3 | 7.7 |

Table 22. External Circuit Example

■ Speaker Output

The output signal from analog volume is converted into a mono signal $[(L+R)/2]$ and this signal is input to the Speaker-amp via the ALC2 circuit. This Speaker-amp is a mono output controlled by BTL and can output a maximum of 150mW@8Ω when HVDD = 3.3V.

Speaker blocks (MOUT2, ALC2 and Speaker-amp) can be powered up/down by controlling the PMSPK bit. When the PMSPK bit is “0”, the MOUT2, SPP and SPN pins are placed in a Hi-Z state.

When the SPPS bit is “0”, the Speaker-amp enters power-save-mode. In this mode, the SPP pin is placed in a Hi-Z state and the SPN pin goes to HVDD/2 voltage. And then the Speaker output gradually changes to the HVDD/2 voltage and this mode can reduce pop noise at power-up. When the AK4538 is powered down, pop noise can be also reduced by first entering power-save-mode.

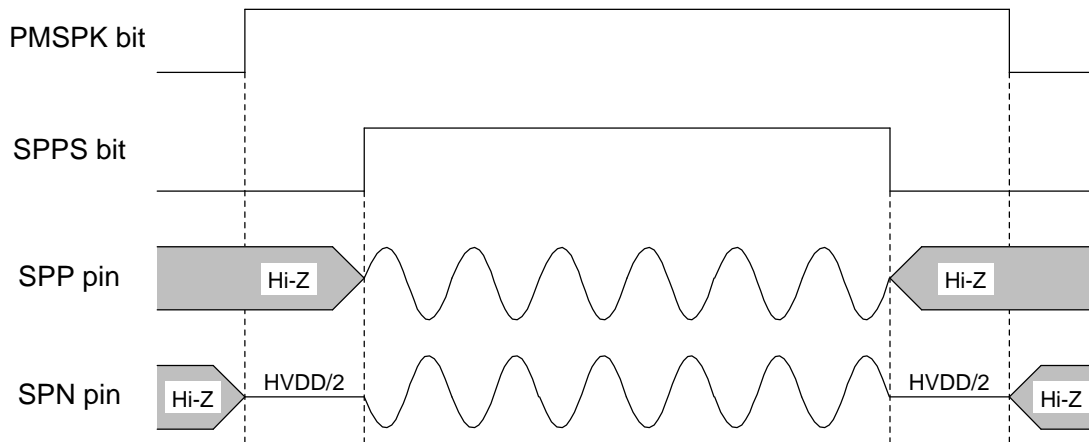

Figure 28. Power-up/Power-down Timing for Speaker-amp

■ MONO OUTPUT (MOUT2 pin)

The mixed Lch/Rch signal of DAC is output from the MOUT2 pin. When the MOUT2 bit is “0”, this output is OFF and the MOUT2 pin is forced to VCOM voltage. The load impedance is 10kΩ (min.). When the PMSPK bit is “0”, the Speaker-amp enters power-down-mode and the output is placed in a Hi-Z state.

■ ALC2 Operation

Input resistance of the ALC2 is 24kΩ (typ) and centered around VCOM voltage, and the input signal level is -3.1dBV. (see Figure 29. 0dBV=1Vrms=2.828Vpp)

The limiter detection level is proportional to HVDD. The output level is limited by the ALC2 circuit when the input signal exceeds -5.2dBV (=FS-1.9dB@HVDD=3.3V). When a continuous signal of -5.2dBV or greater is input to the ALC2 circuit, the change period of the ALC2 limiter operation is set by the ROTM bit and the attenuation level is 0.5dB/step.

The ALC2 recovery operation uses zero crossings and gains of 1dB/step. The ALC2 recovery operation is done until the input level of the Speaker-amp goes to -7.2dBV(=FS-3.9dB@HVDD=3.3V). The ROTM bit sets the ALC2 recovery operation period.

When the input signal is between -5.2dBV and -7.2dBV, the ALC2 limiter or recovery operations are not done.

When the PMSPK bit changes from “0” to “1”, the initialization cycle (2048/fs = 46.4ms @fs=44.1kHz at ROTM bit = “0”, 512/fs = 11.4ms @fs=44.1kHz at the ROTM bit = “1”) starts. The ALC2 is disabled during the initialization cycle and the ALC2 starts after completing the initialization cycle.

| Parameter | | ALC2 Limiter operation | ALC2 Recovery operation |
|-------------------------|----------------|-----------------------------|------------------------------|
| Operation Start Level | | -5.2dBV | -7.2dBV |
| Period | ROTM bit = “0” | 2/fs = 45μs (at 44.1kHz) | 2048/fs=46.4ms (at 44.1kHz) |
| | ROTM bit = “1” | 2/fs = 180μs (at 11.025kHz) | 512/fs=46.4ms (at 11.025kHz) |
| Zero-crossing Detection | | No | Yes (Timeout = Period Time) |
| ATT/GAIN | | 0.5dB step | 1dB step |

Table 23. Limiter /Recovery of ALC2 at HVDD=3.3V

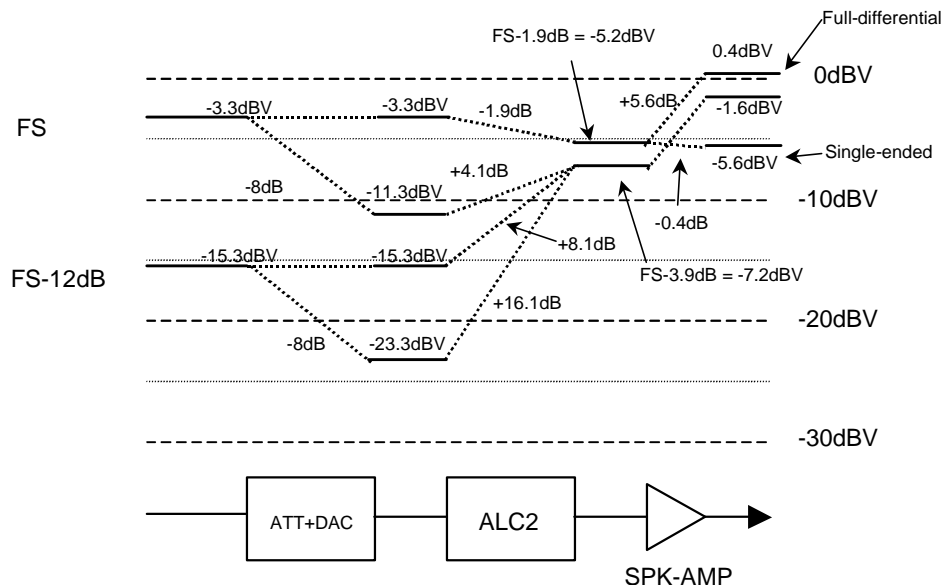

Figure 29. Speaker-amp Output Level Diagram (HVDD=3.3V, DATT=-8.0dB)

■ Stereo LINE OUTPUT (LOUT and ROUT pins)

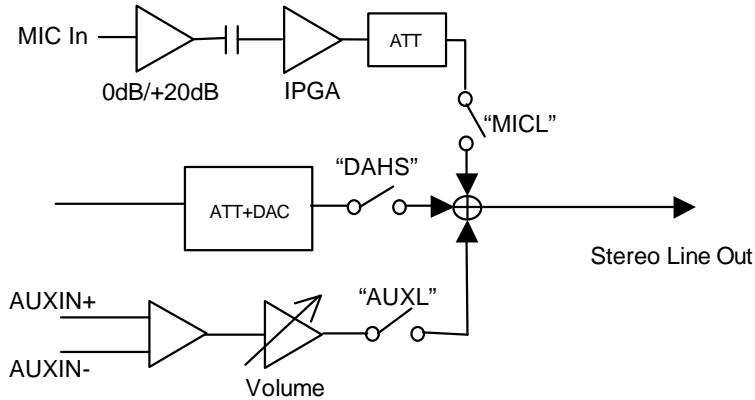

Figure 30. Stereo Line Output

Line out path doesn't have Volume but the output signal level can be controlled by the attenuator of DAC, Volume of Mic In and AUX In. There aren't mute circuits to remove POP noise at power up and down for Line Output.

■ MONO LINE OUTPUT (MOUT+ and MOUT- pins)

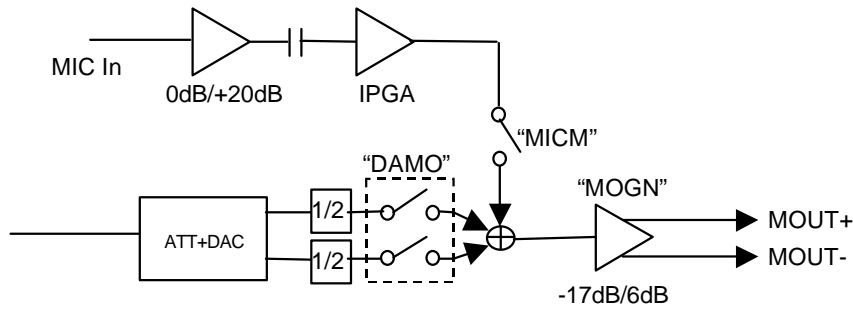

Figure 31. Mono Output

Mono mixer mixes signal from MIC In, Lch signal and Rch signal from DAC. This mixed signal is output from the MOUT+ and MOUT- pins, creating a differential output. Either the MOUT+ or MOUT- pins can be also used as single-ended output. Amp for mono output has 6dB gain and -17dB gain that are set by the MOGN bit.

■ Serial Control Interface

(1) 4-wire Serial Control Mode (I2C pin = “L”)

Internal registers may be written by using the 4-wire μ P interface pins (CSN, CCLK, CDTI and CDTO). The data on this interface consists of a 2-bit Chip address, Read/Write, Register address (MSB first, 5bits) and Control data (MSB first, 8bits). The chip address high bit is fixed to “1” and the lower bit is set by the CAD0 pin. Address and data is clocked in on the rising edge of CCLK and data is clocked out on the falling edge. After a low-to-high transition of CSN, data is latched for write operations and CDTO bit outputs Hi-Z. The clock speed of CCLK is 5MHz (max). The value of internal registers is initialized at PDN pin = “L”.

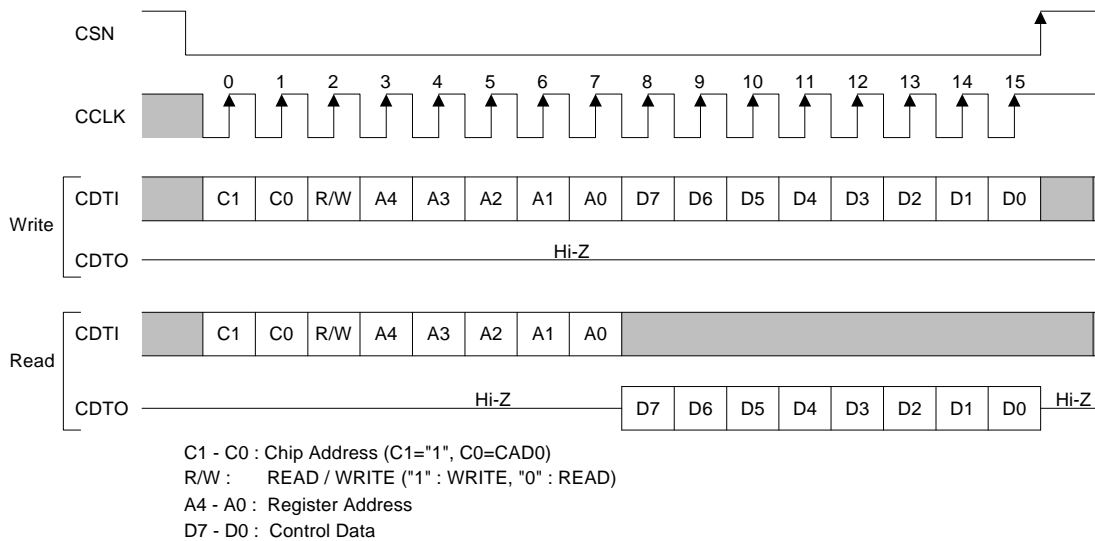

Figure 32. Serial Control I/F Timing

(2) I²C-bus Control Mode (I2C pin = "H")

The AK4538 supports the standard-mode I²C-bus (max: 100kHz). The AK4538 does not support a fast-mode I²C-bus system (max: 400kHz).

(2)-1. WRITE Operations

Figure 33 shows the data transfer sequence for the I²C-bus mode. All commands are preceded by a START condition. A HIGH to LOW transition on the SDA line while SCL is HIGH indicates a START condition (Figure 39). After the START condition, a slave address is sent. This address is 7 bits long followed by an eighth bit that is a data direction bit (R/W). The most significant five bits of the slave address are fixed as "00100". The next two bits are CAD1 and CAD0 (device address bits). These two bits identify the specific device on the bus. The hard-wired input pins (CAD1 and CAD0 pins) set these device address bits (Figure 34). If the slave address matches that of the AK4538, the AK4538 generates an acknowledge and the operation is executed. The master must generate the acknowledge-related clock pulse and release the SDA line (HIGH) during the acknowledge clock pulse (Figure 40). A R/W bit value of "1" indicates that the read operation is to be executed. A "0" indicates that the write operation is to be executed.

The second byte consists of the control register address of the AK4538. The format is MSB first, and those most significant 3-bits are fixed to zeros (Figure 35). The data after the second byte contains control data. The format is MSB first, 8bits (Figure 36). The AK4538 generates an acknowledge after each byte has been received. A data transfer is always terminated by a STOP condition generated by the master. A LOW to HIGH transition on the SDA line while SCL is HIGH defines a STOP condition (Figure 39).

The AK4538 can perform more than one byte write operation per sequence. After receipt of the third byte the AK4538 generates an acknowledge and awaits the next data. The master can transmit more than one byte instead of terminating the write cycle after the first data byte is transferred. After receiving each data packet the internal 5-bit address counter is incremented by one, and the next data is automatically taken into the next address. If the address exceeds 0FH prior to generating the stop condition, the address counter will "roll over" to 00H and the previous data will be overwritten.

The data on the SDA line must remain stable during the HIGH period of the clock. The HIGH or LOW state of the data line can only change when the clock signal on the SCL line is LOW (Figure 41) except for the START and STOP conditions.

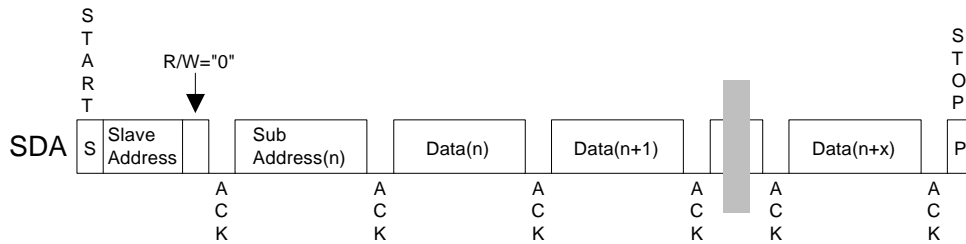
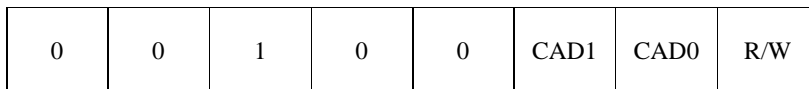

Figure 33. Data Transfer Sequence at the I²C-Bus Mode



(Those CAD1/0 should match with CAD1/0 pins)

Figure 34. The First Byte

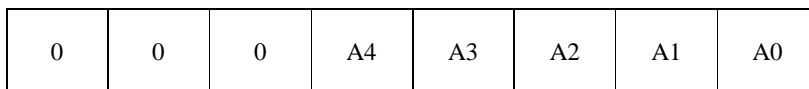

Figure 35. The Second Byte

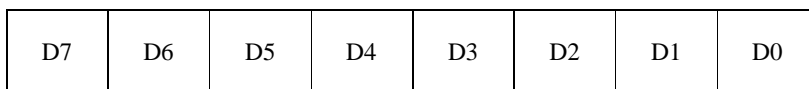

Figure 36. Byte Structure after the second byte

(2)-2. READ Operations

Set the R/W bit = "1" for the READ operation of the AK4538. After transmission of data, the master can read the next address's data by generating an acknowledge instead of terminating the write cycle after the receipt of the first data word. After receiving each data packet the internal 5-bit address counter is incremented by one, and the next data is automatically taken into the next address. If the address exceeds 0FH prior to generating a stop condition, the address counter will "roll over" to 00H and the previous data will be overwritten.

The AK4538 supports two basic read operations: CURRENT ADDRESS READ and RANDOM ADDRESS READ.

(2)-2-1. CURRENT ADDRESS READ

The AK4538 contains an internal address counter that maintains the address of the last word accessed, incremented by one. Therefore, if the last access (either a read or write) were to address n, the next CURRENT READ operation would access data from the address n+1. After receipt of the slave address with R/W bit set to "1", the AK4538 generates an acknowledge, transmits 1-byte of data to the address set by the internal address counter and increments the internal address counter by 1. If the master does not generate an acknowledge to the data but instead generates a stop condition, the AK4538 ceases transmission.

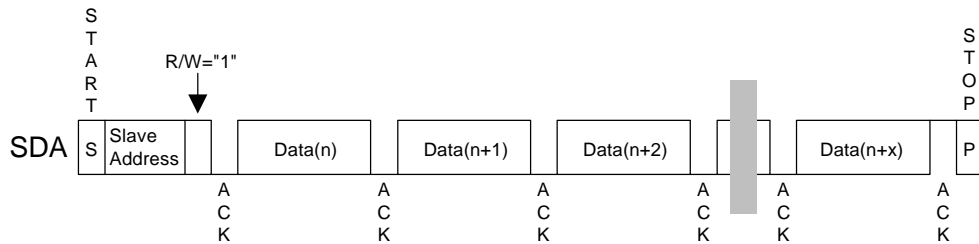

Figure 37. CURRENT ADDRESS READ

(2)-2-2. RANDOM ADDRESS READ

The random read operation allows the master to access any memory location at random. Prior to issuing the slave address with the R/W bit set to "1", the master must first perform a "dummy" write operation. The master issues a start request, a slave address (R/W bit = "0") and then the register address to read. After the register address is acknowledged, the master immediately reissues the start request and the slave address with the R/W bit set to "1". The AK4538 then generates an acknowledge, 1 byte of data and increments the internal address counter by 1. If the master does not generate an acknowledge to the data but instead generates a stop condition, the AK4538 ceases transmission.

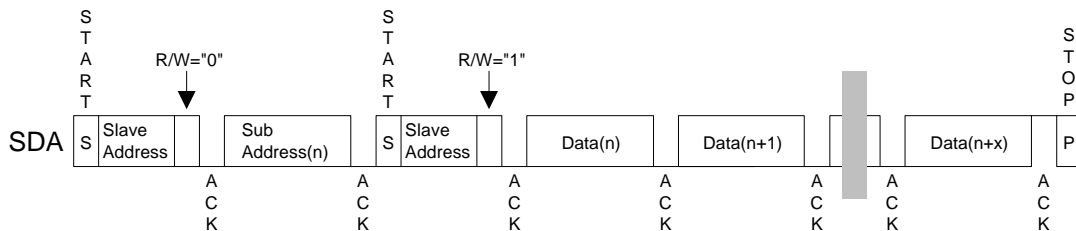

Figure 38. RANDOM ADDRESS READ

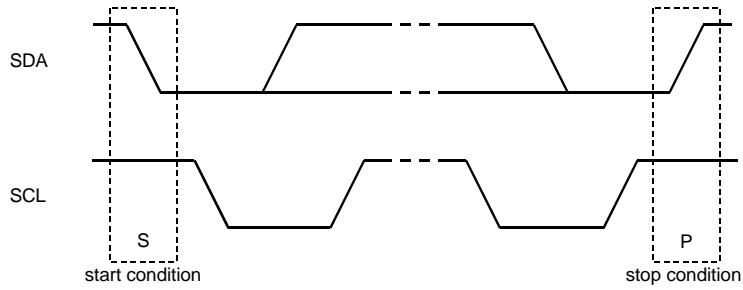

Figure 39. START and STOP Conditions

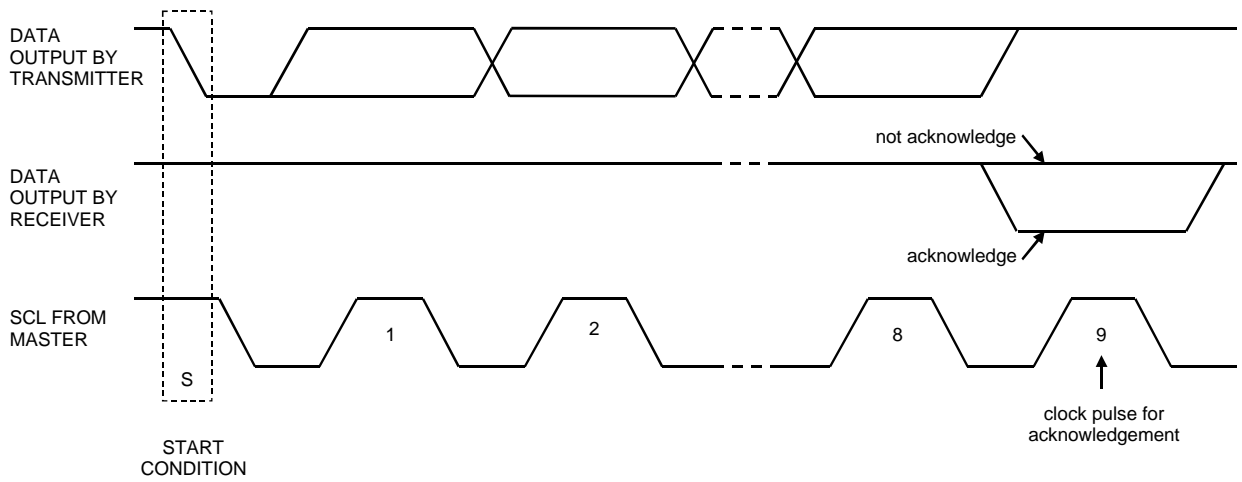

Figure 40. Acknowledge on the I²C-Bus

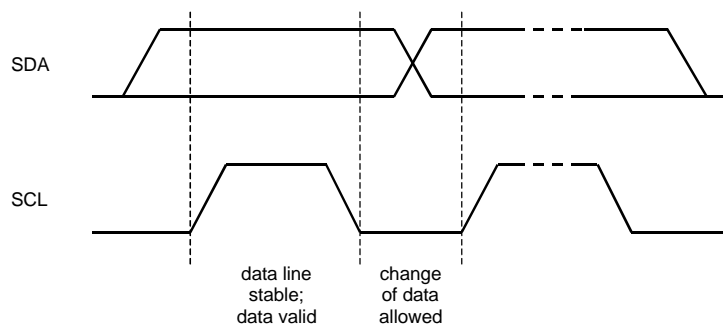

Figure 41. Bit Transfer on the I²C-Bus

■ Register Map

| Addr | Register Name | D7 | D6 | D5 | D4 | D3 | D2 | D1 | D0 |
|------|-------------------------|-------|-------|-------|-------|-------|-------|-------|-------|
| 00H | Power Management 1 | PMVCM | PMBPS | PMBPM | PMLO | PMMO | PMAUX | PMMIC | PMADC |
| 01H | Power Management 2 | MCKPD | PMXTL | PMPLL | 0 | PMSPK | PMHPL | PMHPR | PMDAC |
| 02H | Signal Select 1 | MOGN | PSMO | DAMO | MICM | BPSSP | BPMSP | ALCS | MOUT2 |
| 03H | Signal Select 2 | DAHS | PSLO | AUXL | MICL | BPSHP | BPMHP | HPL | HPR |
| 04H | Mode Control 1 | PLL1 | PLL0 | PS1 | PS0 | MCKO | BF | DIF1 | DIF0 |
| 05H | Mode Control 2 | FS2 | FS1 | FS0 | HPRM | HPLM | HPM | LOOP | SPPS |
| 06H | DAC Control | TM1 | TM0 | SMUTE | DATTC | BST1 | BST0 | DEM1 | DEM0 |
| 07H | MIC Control | 0 | 0 | AUXAD | MPWRE | MPWRI | MICAD | MSEL | MGAIN |
| 08H | Timer Select | 0 | ROTM | ZTM1 | ZTM0 | WTM1 | WTM0 | LTM1 | LTM0 |
| 09H | ALC Mode Control 1 | 0 | ALC2 | ALC1 | ZELM | LMAT1 | LMAT0 | RATT | LMTH |
| 0AH | ALC Mode Control 2 | 0 | REF6 | ERF5 | REF4 | REF3 | REF2 | REF1 | REF0 |
| 0BH | Input PGA Control | 0 | IPGA6 | IPGA5 | IPGA4 | IPGA3 | IPGA2 | IPGA1 | IPGA0 |
| 0CH | Lch Digital ATT Control | ATTL7 | ATTL6 | ATTL5 | ATTL4 | ATTL3 | ATTL2 | ATTL1 | ATTL0 |
| 0DH | Rch Digital ATT Control | ATTR7 | ATTR6 | ATTR5 | ATTR4 | ATTR3 | ATTR2 | ATTR1 | ATTR0 |
| 0EH | Volume Control | ATTM | ATTS2 | ATTS1 | ATTS0 | GN3 | GN2 | GN1 | GN0 |
| 0FH | Status | 0 | 0 | 0 | 0 | 0 | 0 | 0 | DTMIC |

The PDN pin = “L” resets the registers to their default values.

Note: Unused bits must contain a “0” value.

Note: Only write to address 00H to 0FH.

■ Register Definitions

| Addr | Register Name | D7 | D6 | D5 | D4 | D3 | D2 | D1 | D0 |
|------|--------------------|-------|-------|-------|------|------|-------|-------|-------|
| 00H | Power Management 1 | PMVCM | PMBPS | PMBPM | PMLO | PMMO | PMAUX | PMMIC | PMADC |
| | R/W | R/W | R/W | R/W | R/W | R/W | R/W | R/W | R/W |
| | Default | 0 | 0 | 0 | 0 | 0 | 0 | 0 | 0 |

PMADC: ADC Block Power Control

0: Power down (Default)

1: Power up

When the PMADC bit changes from “0” to “1”, the initialization cycle (2081/fs=47.2ms@44.1kHz) starts. After initializing, digital data of the ADC is output.

PMMIC: MIC In Block Power Control

0: Power down (Default)

1: Power up

PMAUX: AUX In Power Control

0: Power down (Default)

1: Power up

PMMO: Mono Line Out Power Control

0: Power down (Default)

1: Power up

PMLO: Line Out Power Control

0: Power down (Default)

1: Power up

PMBPM: Mono BEEP In Power Control

0: Power down (Default)

1: Power up

PMBPS: Stereo BEEP In Power Control

0: Power down (Default)

1: Power up

PMVCM: VCOM Block Power Control

0: Power down (Default)

1: Power up

Each block can be powered down respectively by writing “0” in each bit. When the PDN pin is “L”, all blocks are powered down.

When all bits except MCKPD bit are “0” in the 00H and 01H addresses, all blocks are powered down. The register values remain unchanged.

When any of the blocks are powered up, the PMVCM bit must be set to “1”.

MCLK, BICK and LRCK must always be present unless PMMIC=PMADC=PMDAC=PMSPK= “0” or PDN pin = “L”.

| Addr | Register Name | D7 | D6 | D5 | D4 | D3 | D2 | D1 | D0 |
|------|--------------------|-------|-------|-------|----|-------|-------|-------|-------|
| 01H | Power Management 2 | MCKPD | PMXTL | PMPLL | 0 | PMSPK | PMHPL | PMHPR | PMDAC |
| | R/W | R/W | R/W | R/W | RD | R/W | R/W | R/W | R/W |
| | Default | 1 | 0 | 0 | 0 | 0 | 0 | 0 | 0 |

PMDAC: DAC Block Power Control

0: Power down (Default)

1: Power up

PMHPR: Rch of Headphone-Amp Power Control

0: Power down (Default)

1: Power up

PMHPL: Lch of Headphone-Amp Power Control

0: Power down (Default)

1: Power up

PMSPK: Speaker Block Power Control

0: Power down (Default)

1: Power up

PMPLL: PLL Block Power Control Select

0: PLL is Power down and External is selected. (Default)

1: PLL is Power up and PLL Mode is selected.

PMXTL: X'tal Oscillation Block Power Control

0: Power down (Default)

1: Power up

MCKPD: MCKI pin pull down control

0: Master Clock input enable

1: Pulled down by 25k Ω (Default)

| Addr | Register Name | D7 | D6 | D5 | D4 | D3 | D2 | D1 | D0 |
|------|-----------------|------|------|------|------|-------|-------|------|-------|
| 02H | Signal Select 1 | MOGN | PSMO | DAMO | MICM | BPSSP | BPMSP | ALCS | MOUT2 |
| | R/W | R/W | R/W | R/W | R/W | R/W | R/W | R/W | R/W |
| | Default | 0 | 0 | 0 | 0 | 0 | 0 | 0 | 0 |

MOUT2: MOUT2 Output Enable (Mixing = (L+R)/2)

0: OFF (Default)

1: ON

When the MOUT2 bit = "0", the MOUT2 pin outputs VCOM voltage. The MOUT2 pin outputs signal at the MOUT2 bit = "1". This bit is valid at the PMSPK bit = "1". Hi-Z is output at the PMSPK bit = "0".

ALCS: ALC2 to Speaker-amp Enable

0: OFF (Default)

1: ON

ALC2 output signal is mixed to Speaker-amp at the ALCS bit = "1".

MICM: Switch Control from Mic In to Mono Mixer.

0: OFF (Default)

1: ON

BPMSP: BEEP to Speaker-amp Enable

0: OFF (Default)

1: ON

Mono BEEP signal (BEEP pin) is mixed to Speaker-amp at the BPMSP bit = "1".

BPSSP: BEEPL/BEEPR to Speaker-amp Enable

0: OFF (Default)

1: ON

Stereo BEEP signals (BEEPL/BEEPR pins) are mixed to Speaker-amp at the BPSSP bit = "1".

DAMO: DAC to MOUT+/MOUT- Enable

0: OFF (Default)

1: ON

DAC output signal is output through Mono Line Output (MOUT+/MOUT-pins) at the DAMO bit = "1".

PSMO: MOUT+/MOUT- Output Enable (Mixing = (L+R)/2)

0: Power Save Mode (Default)

1: ON

When the PSMO bit = "0", Mono Line Output is in power save mode and the MOUT+ and MOUT- pins output AVDD/2 voltage.

MOGN: Gain control for mono output

0: +6dB (Default)

1: -17dB

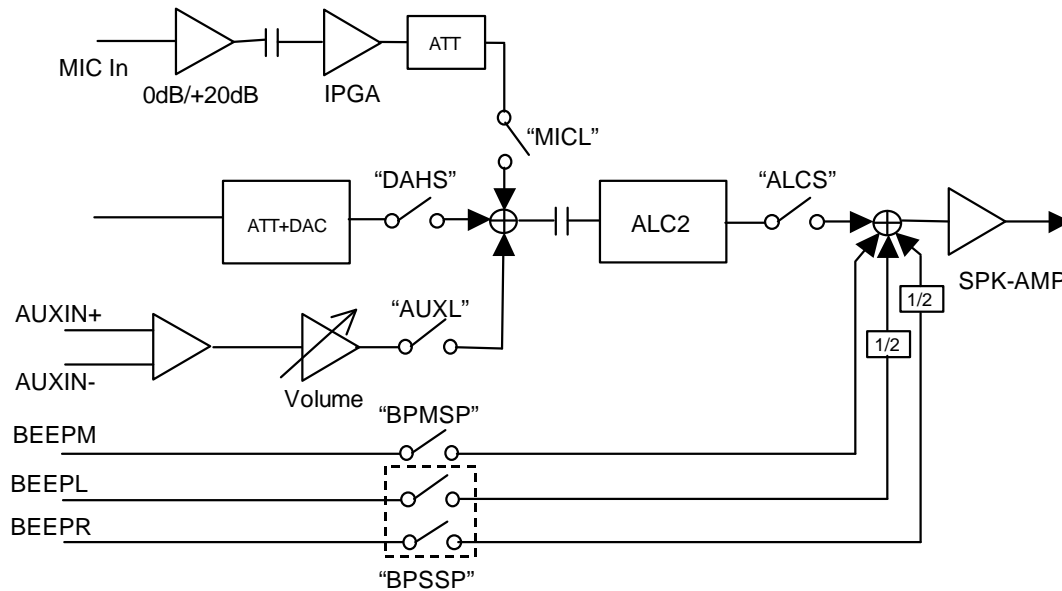

Figure 42. Speaker-amp switch control

| Addr | Register Name | D7 | D6 | D5 | D4 | D3 | D2 | D1 | D0 |
|------|-----------------|------|------|------|------|-------|-------|-----|-----|
| 03H | Signal Select 2 | DAHS | PSLO | AUXL | MICL | BPSHP | BPMHP | HPL | HPR |
| | R/W | R/W | R/W | R/W | R/W | R/W | R/W | R/W | R/W |
| | Default | 0 | 0 | 0 | 0 | 0 | 0 | 1 | 1 |

HPR: Rch Headphone-amp Disable
 0: Normal Operation
 1: OFF(Default)
 The HPR bit should be always “0” during operation.

HPL: Lch Headphone-amp Disable
 0: Normal Operation
 1: OFF(Default)
 The HPL bit should be always “0” during operation.

BPMHP: BEEP M to Headphone-amp Enable
 0: OFF (Default)
 1: ON
 Mono BEEP signal (BEEP M) is mixed to Headphone-amp at the BPMHP bit = “1”.

BPSHP: BEEP L/BEEP R to Headphone-amp Enable
 0: OFF (Default)
 1: ON
 Stereo BEEP signals (BEEP L/BEEP R) is mixed to Headphone-amp at the BPSHP bit = “1”.

MICL: Switch Control from MIC IN to Stereo Mixer.
 0: OFF (Default)
 1: ON

AUXL: Switch Control from AUX IN to Stereo Mixer.
 0: OFF (Default)
 1: ON

PSLO: Select LINEOUT

0: OFF. Power-Save-Mode. Output AVDD/2 voltage. (Default)
 1: ON

Note) LOUT and ROUT pins are Hi-Z at PMLO= "0"

DAHS: DAC to Headphone-amp and MOUT2 Enable

0: OFF (Default)

1: ON

DAC signal is mixed to Headphone-amp and MOUT2 at the DAHS bit = "1".

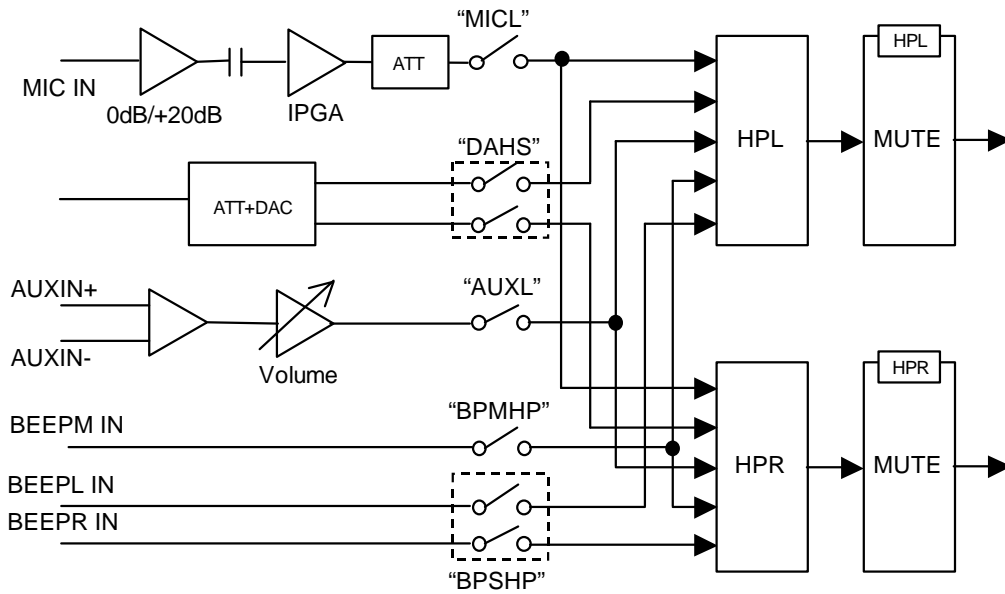

Figure 43. Headphone-amp switch control

| Addr | Register Name | D7 | D6 | D5 | D4 | D3 | D2 | D1 | D0 |
|------|----------------|------|------|-----|-----|------|-----|------|------|
| 04H | Mode Control 1 | PLL1 | PLL0 | PS1 | PS0 | MCKO | BF | DIF1 | DIF0 |
| | R/W | R/W | R/W | R/W | R/W | R/W | R/W | R/W | R/W |
| | Default | 0 | 0 | 0 | 0 | 0 | 0 | 1 | 0 |

DIF1-0: Audio Interface Format Select (see Table 13)

Default: "10" (ADC: I²S, DAC: I²S)

BF: BICK frequency Select at Master Mode

0: 64fs (Default)

1: 32fs

This bit is invalid in slave mode.

MCKO: Master Clock Output Enable

0: Disable (Default)

1: Enable

PS1-0: Output Master Clock Select (see Table 4, 8)

Default: "00" (256fs)

PLL1-0: Input Master Clock Select at PLL Mode (see Table 2)

Default: "00" (12.288MHz)

| Addr | Register Name | D7 | D6 | D5 | D4 | D3 | D2 | D1 | D0 |
|------|----------------|-----|-----|-----|------|------|-----|------|------|
| 05H | Mode Control 2 | FS2 | FS1 | FS0 | HPRM | HPLM | HPM | LOOP | SPPS |
| | R/W | R/W | R/W | R/W | R/W | R/W | R/W | R/W | R/W |
| | Default | 0 | 0 | 0 | 0 | 0 | 0 | 0 | 0 |

SPPS: Speaker-amp Power-Save-Mode

0: Power Save Mode (Default)

1: Normal Operation

When the SPPS bit = "1", the Speaker-amp is in power-save-mode and the SPP pin becomes Hi-z and SPN pin is set to HVDD/2 voltage. When the PMSPK bit = "1", this bit is valid. After the PDN pin changes from "L" to "H", the PMSPK bit is "0", which powers down Speaker-amp

LOOP: Loopback ON/OFF

0: OFF (Default)

1: ON

When this bit is "1", the ADC output is passed to the DAC input internally. The external input data to DAC is ignored.

HPM: Mono output select of Headphone

0: Stereo (Default)

1: Mono.

When the HPM bit = "1", (L+R)/2 signals are output to Lch and Rch of the Headphone-amp. Do not power down the PMHPL and PMHPR bits when in this mode.

HPLM: Lch of HP-Amp output control

0: Enable output from Rch of Headphone-amp (Default)

1: Lch mono output of Headphone-amp. The PMHPR bit can be powered down at this time.

HPRM: Rch of HP-Amp output control

0: Enable output from Lch of Headphone-amp (Default)

1: Rch mono output of Headphone-amp. The PMHPL bit can be powered down at this time.

| Output Channel | | Register bit | | | |
|----------------|-----|----------------|-------|----------------|------------|
| | | Register : 00H | | Register : 05H | |
| Lch | Rch | PMHPL | PMHPR | HPLM | HPRM |
| ON | ON | 1 | 1 | 0 | 0 |
| ON | OFF | 1 | 0 | 1 | 0 |
| OFF | ON | 0 | 1 | 0 | 1 |
| OFF | OFF | 0 | 0 | Don't Care | Don't Care |

Table 24. Output control for Headphone-amp

FS2-0: Sampling frequency modes (see Table 3 and Table 7)

Default: "000" (fs=44.1kHz)

| Addr | Register Name | D7 | D6 | D5 | D4 | D3 | D2 | D1 | D0 |
|------|---------------|-----|-----|-------|-------|------|------|------|------|
| 06H | DAC Control | TM1 | TM0 | SMUTE | DATTC | BST1 | BST0 | DEM1 | DEM0 |
| | R/W | R/W | R/W | R/W | R/W | R/W | R/W | R/W | R/W |
| | Default | 0 | 0 | 0 | 1 | 0 | 0 | 0 | 1 |

DEM1-0: De-emphasizes response (see Table 18)

Default is "01" (OFF).

BST1-0: Select Low Frequency Boost Function (see Table 19)

Default is "00" (OFF).

DATTC: DAC Digital Attenuator Control Mode Select

0: ATTL7-0 and ATTR7-0 bits control the attenuator level of Lch and Rch respectively.

1: ATTL7-0 bits control both Lch and Rch at same time. (Default)

ATTR7-0 bits are not changed when the ATTL7-0 bits are written.

SMUTE: Soft Mute Control

0: Normal Operation (Default)

1: DAC outputs soft-muted

Soft mute operation is independent of digital attenuator and is performed in the digital domain.

TM1-0: Soft Mute Time Select (see Table 25)

Default: "00" (1024/fs)

| TM1 | TM0 | Cycle | |
|-----|-----|---------|---------|
| 0 | 0 | 1024/fs | Default |
| 0 | 1 | 512/fs | |
| 1 | 0 | 256/fs | |
| 1 | 1 | 128/fs | |

Table 25. Soft Mute Time Setting

| Addr | Register Name | D7 | D6 | D5 | D4 | D3 | D2 | D1 | D0 |
|------|----------------|----|----|-------|-------|-------|-------|------|-------|
| 07H | MIC/HP Control | 0 | 0 | AUXAD | MPWRE | MPWRI | MICAD | MSEL | MGAIN |
| | R/W | RD | RD | R/W | R/W | R/W | R/W | R/W | R/W |
| | Default | 0 | 0 | 0 | 0 | 0 | 0 | 0 | 1 |

MGAIN: 1st Mic-amp Gain control

0: 0dB

1: 20dB (Default)

MSEL: Microphone select

0: Internal Mic (Default)

1: External Mic

MICAD: Switch Control from Mic In to ADC.

0: OFF (Default)

1: ON

MPWRI: Power Supply Control for Internal Microphone

0: OFF (Default)

1: ON

MPWRE: Power Supply for External Microphone

0: OFF (Default)

1: ON

AUXAD: Switch Control from AUX IN to ADC.

0: OFF (Default)

1: ON

| Addr | Register Name | D7 | D6 | D5 | D4 | D3 | D2 | D1 | D0 |
|------|---------------|----|------|------|------|------|------|------|------|
| 08H | Timer Select | 0 | ROTM | ZTM1 | ZTM0 | WTM1 | WTM0 | LTM1 | LTM0 |
| | R/W | RD | R/W | R/W | R/W | R/W | R/W | R/W | R/W |
| | Default | 0 | 0 | 0 | 0 | 0 | 0 | 0 | 0 |

LTM1-0: ALC1 limiter operation period at zero crossing disable (ZELM bit = "1") (see Table 26)

The IPGA value is changed immediately. When the IPGA value is changed continuously, the change is done by the period specified by the LTM1-0 bits. Default is "00" (0.5/fs).

| LTM1 | LTM0 | ALC1 Limiter Operation Period | | | | Default |
|------|------|-------------------------------|-------------|-------------|------------|---------|
| | | | 8kHz | 16kHz | 44.1kHz | |
| 0 | 0 | 0.5/fs | 63 μ s | 31 μ s | 11 μ s | Default |
| 0 | 1 | 1/fs | 125 μ s | 63 μ s | 23 μ s | |
| 1 | 0 | 2/fs | 250 μ s | 125 μ s | 45 μ s | |
| 1 | 1 | 4/fs | 500 μ s | 250 μ s | 91 μ s | |

Table 26. ALC1 Limiter Operation Period at zero crossing disable (ZELM bit = "1")

WTM1-0: ALC1 Recovery Waiting Period (see Table 27)

A period of recovery operation when any limiter operation does not occur during the ALC1 operation. Default is "00" (128/fs).

| ZTM1 | ZTM0 | ALC1 Recovery Operation Waiting Period | | | | Default |
|------|------|--|-------|-------|---------|---------|
| | | | 8kHz | 16kHz | 44.1kHz | |
| 0 | 0 | 128/fs | 16ms | 8ms | 2.9ms | Default |
| 0 | 1 | 256/fs | 32ms | 16ms | 5.8ms | |
| 1 | 0 | 512/fs | 64ms | 32ms | 11.6ms | |
| 1 | 1 | 1024/fs | 128ms | 64ms | 23.2ms | |

Table 27. ALC1 Recovery Operation Waiting Period

ZTM1-0: Zero crossing timeout for the write operation by the μ P, ALC1 recovery, and zero crossing enable (ZELM bit = "0") of the ALC1 operation. (see Table 28)

When the IPGA of each L/R channels perform zero crossing or timeout independently, the IPGA value is changed by the μ P WRITE operation, ALC1 recovery operation or ALC1 limiter operation (ZELM bit = "0"). Default is "00" (128/fs).

| ZTM1 | ZTM0 | Zero Crossing Timeout Period | | | | Default |
|------|------|------------------------------|-------|-------|---------|---------|
| | | | 8kHz | 16kHz | 44.1kHz | |
| 0 | 0 | 128/fs | 16ms | 8ms | 2.9ms | Default |
| 0 | 1 | 256/fs | 32ms | 16ms | 5.8ms | |
| 1 | 0 | 512/fs | 64ms | 32ms | 11.6ms | |
| 1 | 1 | 1024/fs | 128ms | 64ms | 23.2ms | |

Table 28. Zero Crossing Timeout Period

ROTM: Period time for ALC2 Recovery operation

0: 2048/fs (Default)

1: 512/fs

| Addr | Register Name | D7 | D6 | D5 | D4 | D3 | D2 | D1 | D0 |
|------|--------------------|----|------|------|------|-------|-------|------|------|
| 09H | ALC Mode Control 1 | 0 | ALC2 | ALC1 | ZELM | LMAT1 | LMAT0 | RATT | LMTH |
| | R/W | RD | R/W | R/W | R/W | R/W | R/W | R/W | R/W |
| | Default | 0 | 1 | 0 | 0 | 0 | 0 | 0 | 0 |

LMTH: ALC1 Limiter Detection Level / Recovery Waiting Counter Reset Level (see Table 29)

The ALC1 limiter detection level and the ALC1 recovery counter reset level may be offset by about ± 2 dB. Default is "0".

| LMTH | ALC1 Limiter Detection Level | ALC1 Recovery Waiting Counter Reset Level | Default |
|------|------------------------------|---|---------|
| 0 | ADC Input ≥ -6.0 dBFS | -6.0 dBFS > ADC Input ≥ -8.0 dBFS | Default |
| 1 | ADC Input ≥ -4.0 dBFS | -4.0 dBFS > ADC Input ≥ -6.0 dBFS | |

Table 29. ALC1 Limiter Detection Level / Recovery Waiting Counter Reset Level

RATT: ALC1 Recovery GAIN Step (see Table 30)

During the ALC1 recovery operation, the number of steps changed from the current IPGA value is set. For example, when the current IPGA value is 30H and RATT bit = "1" is set, the IPGA changes to 32H by the ALC1 recovery operation and the output signal level is gained up by 1dB ($=0.5$ dB $\times 2$). When the IPGA value exceeds the reference level (REF6-0 bits), the IPGA value does not increase.

| RATT | GAIN STEP | Default |
|------|-----------|---------|
| 0 | 1 | Default |
| 1 | 2 | |

Table 30. ALC1 Recovery Gain Step Setting

LMAT1-0: ALC1 Limiter ATT Step (see Table 31)

During the ALC1 limiter operation, when either Lch or Rch exceeds the ALC1 limiter detection level set by LMTH, the number of steps attenuated from the current IPGA value is set. For example, when the current IPGA value is 47H and the LMAT1-0 bits = "11", the IPGA transition to 43H when the ALC1 limiter operation starts, resulting in the input signal level being attenuated by 2dB ($=0.5$ dB $\times 4$). When the attenuation value exceeds IPGA = "00" (-8 dB), it clips to "00".

| LMAT1 | LMAT0 | ATT STEP | Default |
|-------|-------|----------|---------|
| 0 | 0 | 1 | Default |
| 0 | 1 | 2 | |
| 1 | 0 | 3 | |
| 1 | 1 | 4 | |

Table 31. ALC1 Limiter ATT Step Setting

ZELM: Enable zero crossing detection at ALC1 Limiter operation

0: Enable (Default)

1: Disable

When the ZELM bit = "0", the IPGA of each L/R channel perform a zero crossing or timeout independently and the IPGA value is changed by the ALC1 operation. The zero crossing timeout is the same as the ALC1 recovery operation. When the ZELM bit = "1", the IPGA value is changed immediately.

ALC1: ALC1 Enable Flag

0: ALC1 Disable (Default)

1: ALC1 Enable

ALC2: ALC2 Enable Flag

0: ALC2 Disable

1: ALC2 Enable (Default)

| Addr | Register Name | D7 | D6 | D5 | D4 | D3 | D2 | D1 | D0 |
|------|--------------------|----|------|------|------|------|------|------|------|
| 0AH | ALC Mode Control 2 | 0 | REF6 | REF5 | REF4 | REF3 | REF2 | REF1 | REF0 |
| | R/W | RD | R/W | R/W | R/W | R/W | R/W | R/W | R/W |
| | Default | 0 | 0 | 1 | 1 | 0 | 1 | 1 | 0 |

REF6-0: Reference value at ALC1 Recovery Operation (see Table 32)

During the ALC1 recovery operation, if the IPGA value exceeds the setting reference value by gain operation, then the IPGA does not become larger than the reference value. For example, when REF7-0 = “30H”, RATT = 2step, IPGA = 2FH, even if the input signal does not exceed the “ALC1 Recovery Waiting Counter Reset Level”, the IPGA does not change to 2FH + 2step = 31H, and keeps 30H. Default is “36H”.

| DATA (HEX) | GAIN (dB) | STEP |
|------------|-----------|-------|
| 47 | +27.5 | 0.5dB |
| 46 | +27.0 | |
| 45 | +26.5 | |
| : | : | |
| 36 | +19.0 | |
| : | : | |
| 10 | +0.0 | |
| : | : | |
| 06 | -5.0 | |
| 05 | -5.5 | |
| 04 | -6.0 | |
| 03 | -6.5 | |
| 02 | -7.0 | |
| 01 | -7.5 | |
| 00 | -8.0 | |

Default

Table 32. Setting Reference Value at ALC1 Recovery Operation

| Addr | Register Name | D7 | D6 | D5 | D4 | D3 | D2 | D1 | D0 |
|------|-------------------|----|-------|-------|-------|-------|-------|-------|-------|
| 0BH | Input PGA Control | 0 | IPGA6 | IPGA5 | IPGA4 | IPGA3 | IPGA2 | IPGA1 | IPGA0 |
| | R/W | RD | R/W | R/W | R/W | R/W | R/W | R/W | R/W |
| | Default | 0 | 0 | 0 | 1 | 0 | 0 | 0 | 0 |

IPGA6-0: Input Analog PGA (see Table 33)

Default: "10H" (0dB)

While the ALC1 bit = "1", the gain value set by the ALC1 is not written and therefore the value that is written through the register control I/F is read.

| DATA (HEX) | GAIN (dB) | STEP |
|------------|-----------|-------|
| 47 | +27.5 | 0.5dB |
| 46 | +27.0 | |
| 45 | +26.5 | |
| : | : | |
| 36 | +19.0 | |
| : | : | |
| 10 | +0.0 | |
| : | : | |
| 06 | -5.0 | |
| 05 | -5.5 | |
| 04 | -6.0 | |
| 03 | -6.5 | |
| 02 | -7.0 | |
| 01 | -7.5 | |
| 00 | -8.0 | |

Default

Table 33. Input Gain Setting

| Addr | Register Name | D7 | D6 | D5 | D4 | D3 | D2 | D1 | D0 |
|------|-------------------------|-------|-------|-------|-------|-------|-------|-------|-------|
| 0CH | Lch Digital ATT Control | ATTL7 | ATTL6 | ATTL5 | ATTL4 | ATTL3 | ATTL2 | ATTL1 | ATTL0 |
| 0DH | Rch Digital ATT Control | ATTR7 | ATTR6 | ATTR5 | ATTR4 | ATTR3 | ATTR2 | ATTR1 | ATTR0 |
| | R/W | R/W | R/W | R/W | R/W | R/W | R/W | R/W | R/W |
| | Default | 0 | 0 | 0 | 0 | 0 | 0 | 0 | 0 |

ATTL/R7-0: Digital ATT Output Control (see Table 20)

Default: "00H" (0dB)

| Addr | Register Name | D7 | D6 | D5 | D4 | D3 | D2 | D1 | D0 |
|------|----------------|------|-------|-------|-------|-----|-----|-----|-----|
| 0EH | Volume Control | ATTM | ATTS2 | ATTS1 | ATTS0 | GN3 | GN2 | GN1 | GN0 |
| | R/W | RD | R/W | R/W | R/W | R/W | R/W | R/W | R/W |
| | Default | 0 | 1 | 0 | 1 | 0 | 1 | 1 | 1 |

GN3-0: Volume of AUX In (see Table 21)

ATTS2-0: Attenuator select of signal from MIC IN to Stereo Mixer. (See Table 15)

ATTM: Attenuator control for signal from MIC IN to Mono Mixer

0: OFF. 0dB (Default)

1: ON. -4dB

| Addr | Register Name | D7 | D6 | D5 | D4 | D3 | D2 | D1 | D0 |
|------|---------------|----|----|----|----|----|----|----|-------|
| 0FH | Status | 0 | 0 | 0 | 0 | 0 | 0 | 0 | DTMIC |
| | R/W | RD | RD | RD | RD | RD | RD | RD | RD |
| | Default | 0 | 0 | 0 | 0 | 0 | 0 | 0 | 0 |

DTMIC: Microphone Detection Result

0: Microphone is not detected.(Default)

1: Microphone is detected.

SYSTEM DESIGN (52pin QFN)

Figure 44 shows the system connection diagram for the 52-pin QFN version of the AK4538. An evaluation board [AKD4538] is available which demonstrates the optimum layout, power supply arrangements and measurement results.

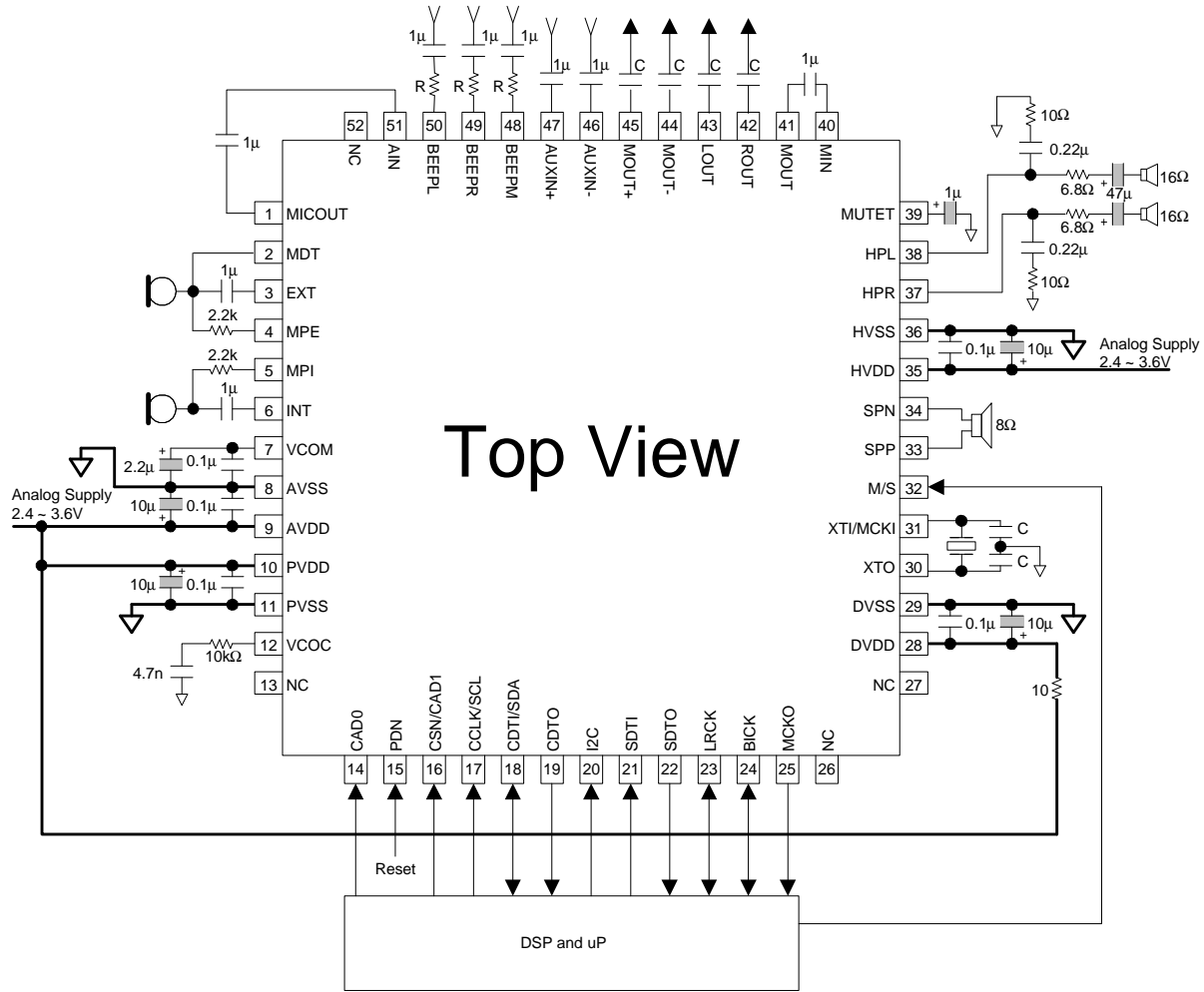

Notes:

- AVSS, DVSS, PVSS and HVSS of the AK4538 should be distributed separately from the ground of external controllers.
- Values of R and C in Figure 44 should depend on system.
- All input pins should not be left floating.

Figure 44. Typical Connection Diagram

1. Grounding and Power Supply Decoupling

The AK4538 requires careful attention to power supply and grounding arrangements. AVDD, DVDD, PVDD and HVDD are usually supplied from the system's analog supply. If AVDD, DVDD, PVDD and HVDD are supplied separately, the correct power up sequence should be observed. AVSS, DVSS, PVSS and HVSS of the AK4538 should be connected to the analog ground plane. System analog ground and digital ground should be connected together near to where the supplies are brought onto the printed circuit board. Decoupling capacitors should be as near to the AK4538 as possible, with the small value ceramic capacitor being the nearest.

2. Voltage Reference

VCOM is a signal ground of this chip. A 2.2 μ F electrolytic capacitor in parallel with a 0.1 μ F ceramic capacitor attached to the VCOM pin eliminates the effects of high frequency noise. No load current may be drawn from the VCOM pin. All signals, especially clocks, should be kept away from the VREF and VCOM pins in order to avoid unwanted coupling into the AK4538.

3. Analog Inputs

The Mic and Beep inputs are single-ended. The input signal range scales with nominally at 0.06 x AVDD Vpp for the Mic input and 0.6 x AVDD Vpp for the Beep input, centered around the internal common voltage (approx. AVDD/2). Usually the input signal is AC coupled using a capacitor. The cut-off frequency is $f_c = (1/2\pi RC)$. The AK4538 can accept input voltages from AVSS to AVDD.

4. Analog Outputs

The input data format for the DAC is 2's complement. The output voltage is a positive full scale for 7FFFH(@16bit) and a negative full scale for 8000H(@16bit). Mono output from the MOUT2 pin and Mono Line Output from the MOUT+ and MOUT- pins are centered at AVDD/2. The Headphone-Amp and Speaker-Amp outputs are centered at HVDD/2.

CONTROL SEQUENCE

■ **Power up**

Upon power-up, bring the PDN pin = “L”. Initialize the internal registers to default values after the PDN pin = “H”. Set the following registers to establish the initial condition.

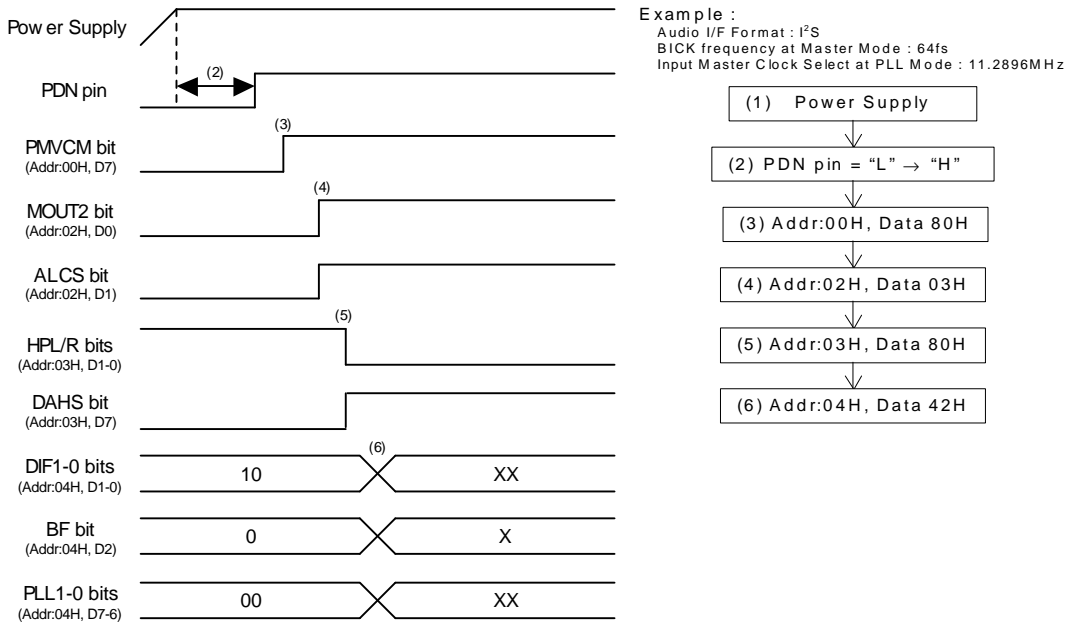

Figure 45. Power Up Sequence

<Example>

- (1) Power Supply
- (2) PDN pin = “L” → “H”
 “L” time of 150ns or more is needed to reset the AK4538.
- (3) Power up VCOM : PMVCM bit = “0” → “1”
 VCOM should first be powered up before the other block operates.
- (4) Set up register 02H : MOUT2 bit = ALCS bit = “0” → “1”
 Set the MOUT2 and ALCS bits to “1” when using the Speaker-amp.
- (5) Set up register 03H : HPL bit = HPR bit = “1” → “0”, DAHS bit = “0” → “1”
- (6) Set up register 04H
 - DIF1-0 bits set the audio interface format.
 - BF bit sets BICK output frequency in master mode.
 - PLL1-0 bits set MCLK input frequency in PLL mode.

■ Clock Set up

When ADC, DAC, ALC1 and ALC2 are used, the clocks (MCLK, BICK and LRCK) must be supplied.

1. When X'tal is used in PLL mode. (Slave mode)

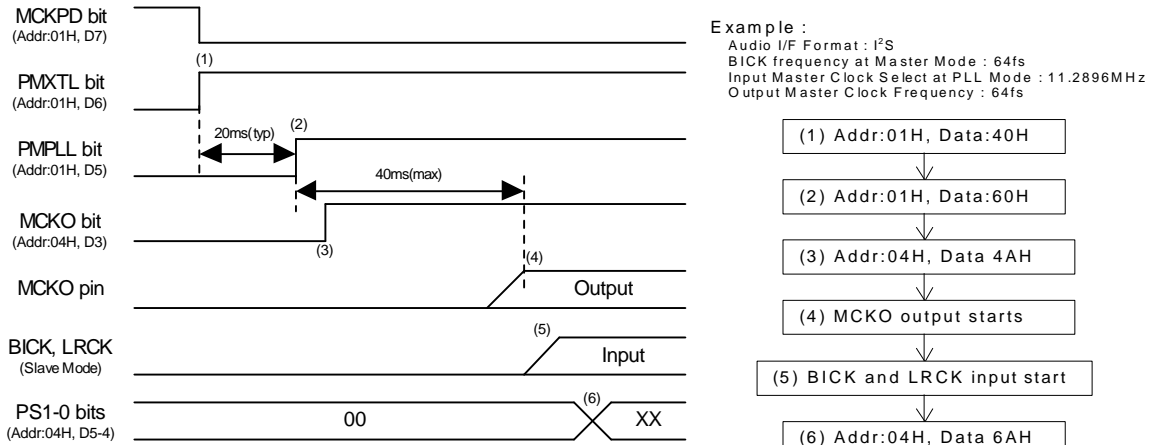

Figure 46. Clock Set Up Sequence(1)

<Example>

- (1) Release the pull-down of the XTI pin : MCKPD bit = “1” → “0” and power-up the X’tal oscillator: PMXTL bit = “0” → “1”
- (2) Power-up the PLL : PMPLL bit = “0” → “1”
 The PLL should be powered-up after the X’tal oscillator becomes stable. If X’tal and PLL are powered-up at the same time, the PLL does not start. It takes X’tal oscillator 20ms(typ) to be stable after PMXTL bit= “1”. This time depends on X’tal. PLL needs 40ms lock time the PMPLL bit = “0” → “1”.
- (3) Enable MCKO output : MCKO bit = “0” → “1”
- (4) MCKO is output after PLL becomes stable.
- (5) Input BICK and LRCK synchronized with the MCKO output.
- (6) Set the MCKO output frequency (PS1-0 bits)
 If PS1-0 bits are changed before LRCK is input, MCKO is not output. PS1-0 bits should be changed after LRCK is input.

2. When X'tal is used in PLL mode. (Master mode)

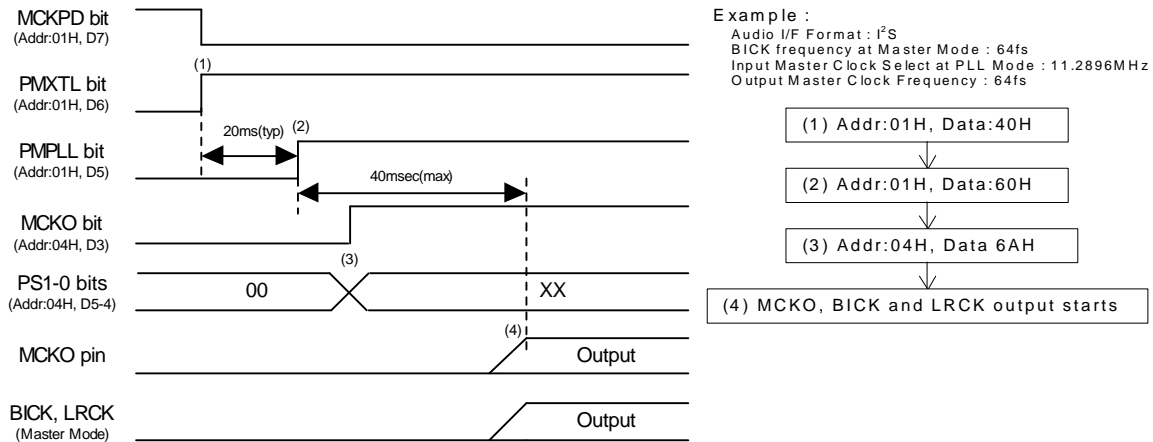

Figure 47. Clock Set Up Sequence(2)

<Example>

- (1) Release the pull-down of the XTI pin : MCKPD bit = "1" → "0" and power-up the X'tal oscillator: PMXTL bit = "0" → "1"
- (2) Power-up PLL : PMPLL bit = "0" → "1"
 The PLL should be powered-up after the X'tal oscillator becomes stable. If X'tal and PLL are powered-up at the same time, the PLL does not start. It takes X'tal oscillator 20ms(typ) to be stable after PMXTL bit= "1". This time depends on X'tal. PLL needs 40ms lock time the PMPLL bit = "0" → "1".
- (3) Enable MCKO output : MCKO bit = "0" → "1" and set up MCKO output frequency (PS1-0 bits)
- (4) MCKO, BICK and LRCK are output after PLL lock time.

3. When an external clock is used in PLL mode. (Slave mode)

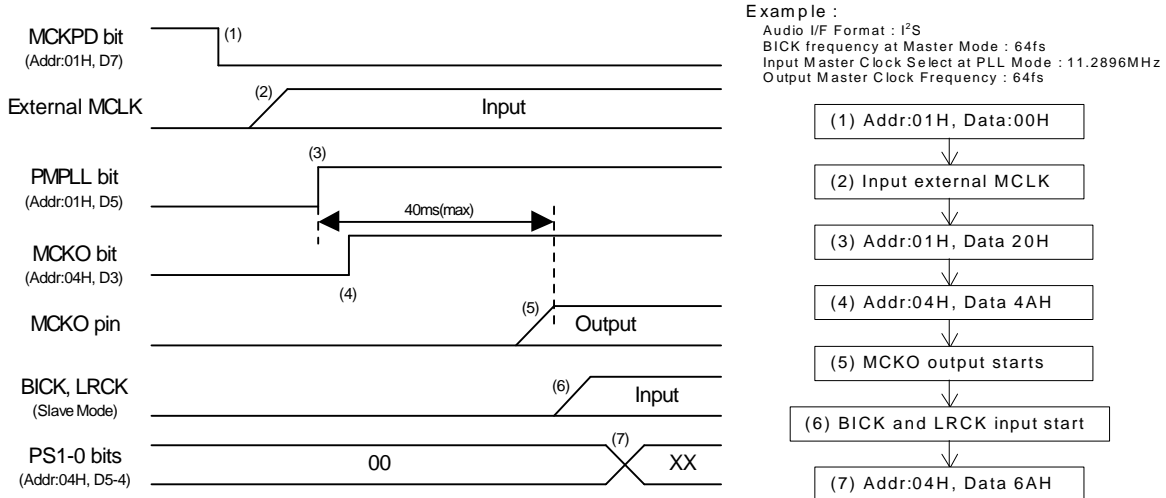

Figure 48. Clock Set Up Sequence(3)

<Example>

- (1) Release the pull-down of the XTI pin : MCKPD bit = "1" → "0"
- (2) Input an external MCLK
- (3) Power-up PLL : PMPLL bit = "0" → "1"
 PLL needs 40ms lock time after the PMPLL bit = "0" → "1".
- (4) Enable MCKO output : MCKO bit = "0" → "1"
- (5) MCKO is output after PLL lock time.
- (6) Input BICK and LRCK that synchronized in the MCKO output.
- (7) Set up MCKO output frequency (PS1-0 bits)
 If PS1-0 bits are changed before LRCK is input, MCKO is not output. PS1-0 bits should be changed after LRCK is input.

4. When an external clock is used in PLL mode. (Master mode)

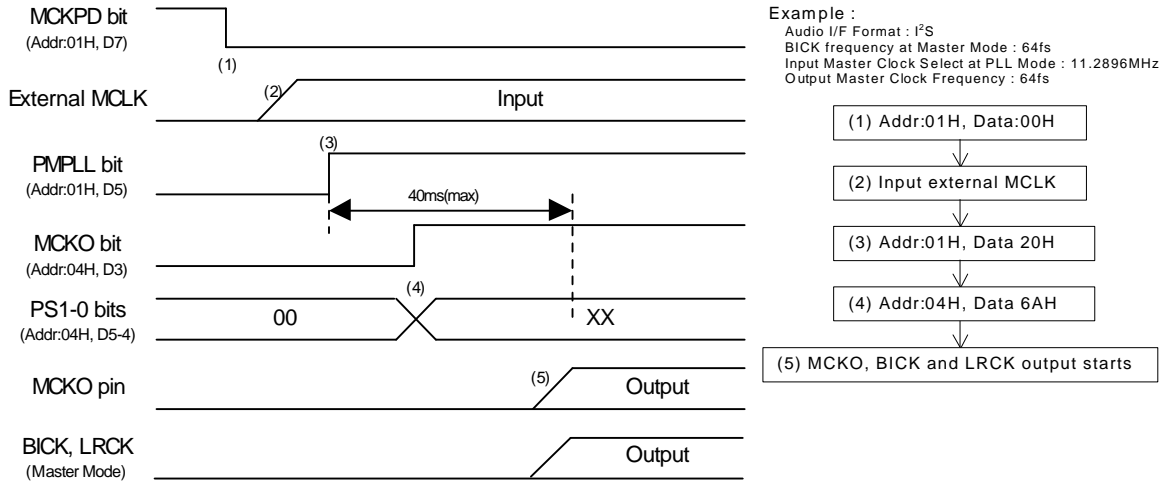

Figure 49. Clock Set Up Sequence(4)

<Example>

- (1) Release the pull-down of the XTI pin : MCKPD bit = "1" → "0"
- (2) Input an external MCLK
- (3) Power-up PLL : PMPLL bit = "0" → "1"
PLL needs 40ms lock time after the PMPLL bit = "0" → "1".
- (4) Enable MCKO output : MCKO bit = "0" → "1" and set up MCKO output frequency (PS1-0 bits)
- (5) MCKO, BICK and LRCK are output after PLL lock time.

5. External clock mode

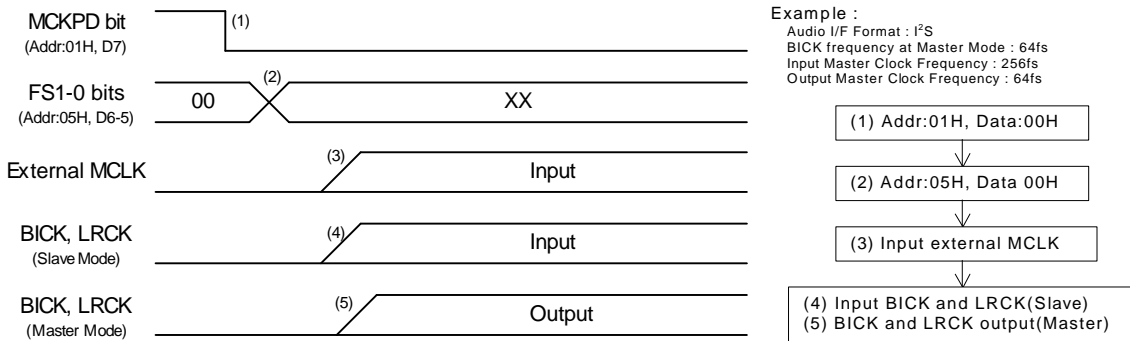

Figure 50. Clock Set Up Sequence(5)

<Example>

- (1) Release the pull-down of the XTI pin : MCKPD bit = "1" → "0"
- (2) Set up MCLK frequency (FS1-0 bits)
- (3) Input an external MCLK
- (4) In slave mode, input MCLK, BICK and LRCK.
- (5) In master mode, while MCLK is input, BICK and LRCK are output.

■ MIC Input Recording

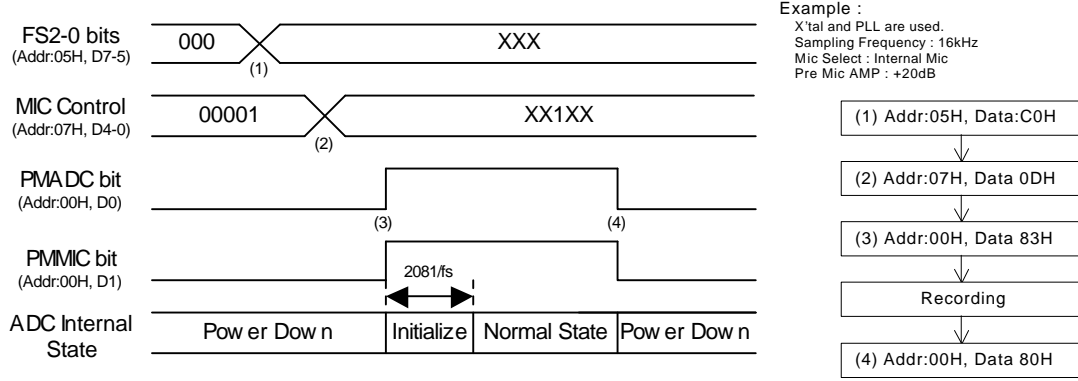

Figure 37. MIC Input Recording Sequence

<Example>

At first, clocks should be supplied according to “Clock Set Up” sequence.

- (1) Set up a sampling frequency (FS2-0 bits) if PLL mode is used.
- (2) Set up MIC input(Addr:07H)
- (3) Power up MIC and ADC : PMMIC bit = PMADC bit = “0” → “1”
 The initialization cycle time of ADC is $2081/f_s = 47.2ms @ f_s = 44.1kHz$.
- (4) Power-down Mic and ADC : PMMIC bit = PMADC bit = “1” → “0”

■ Headphone-amp Output

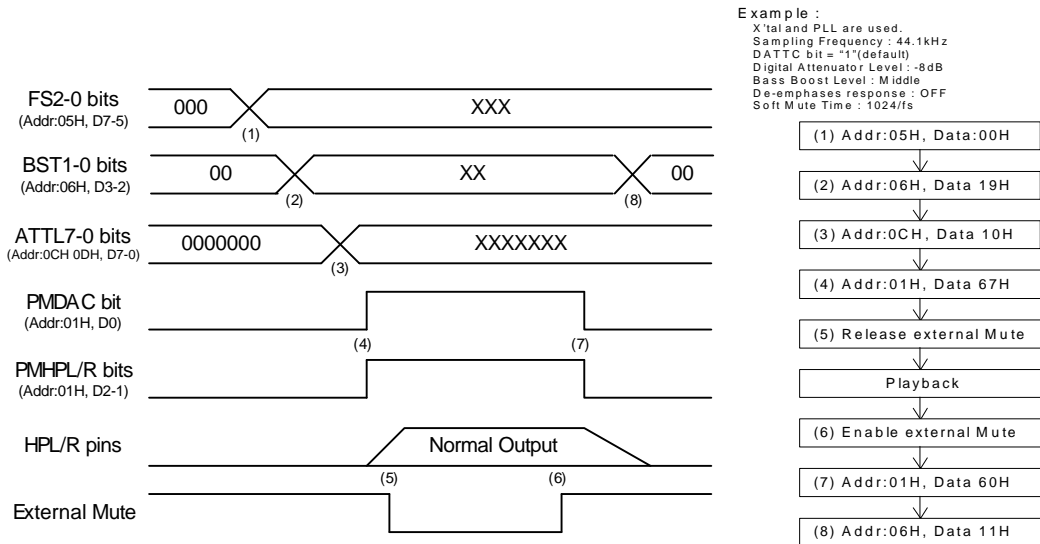

Figure 51. Headphone-Amp Output Sequence

<Example>

At first, clocks should be supplied according to “Clock Set Up” sequence.

- (1) Set up a sampling frequency (FS2-0 bits) if PLL mode is used.
- (2) Set up the low frequency boost level(BST1-0 bits)
- (3) Set up the digital volume(Addr : 0CH and 0DH)

At DATTC bit = “1”(default), ATTL7-0 bits of Address 0CH control both Lch and Rch attenuation level.

- (4) Power up DAC and headphone-amp : PMDAC bit = PMHPL bit = PMHPR bit = “0” → “1”

The rising time after power up Headphone-amp depends on the capacitor value connected with the MUTET pin. When this capacitor value is 1.0μF, the time constant is $\tau_r = 100\text{ms}$.

- (5) Release the external mute.
- (6) Enable the external mute.

- (7) Power down DAC and headphone-amp : PMDAC bit = PMHPL bit = PMHPR bit = “1” → “0”

The falling time of Headphone-amp depends on the capacitor for the AC couple of Headphone-amp output.

When this capacitor value is 47μF, the time constant is $\tau_f = 188\text{ms}$. If the power supply is powered off or Headphone-Amp is powered-up again before the common voltage goes to GND, some POP noise occurs. It takes 5times of τ_f that the common voltage goes to GND.

- (8) Off the low frequency boost level (BST1-0 bits = “00”)

■ Speaker-amp Output

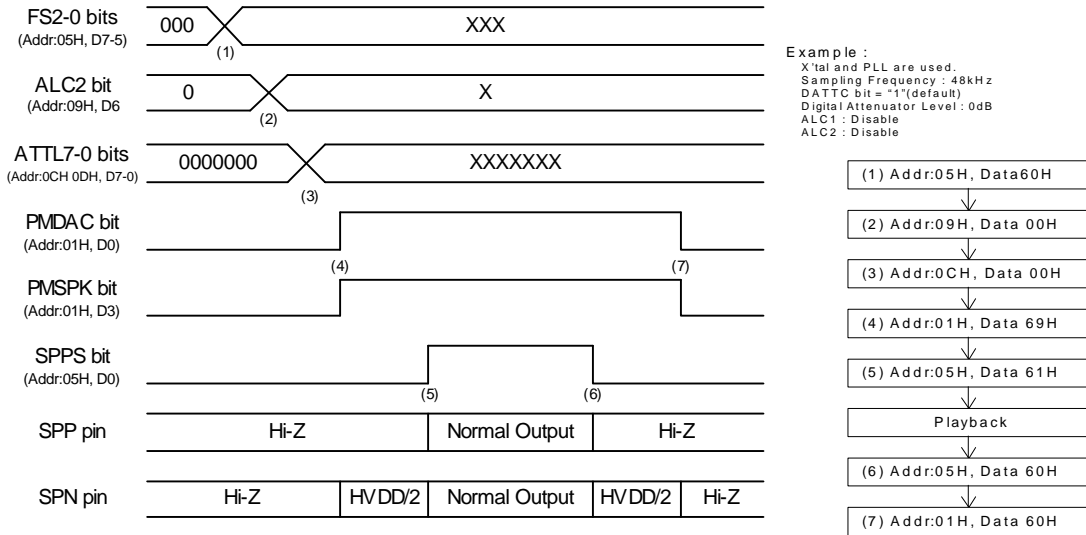

Figure 52. Speaker-Amp Output Sequence

<Example>

At first, clocks should be supplied according to "Clock Set Up" sequence.

- (1) Set up a sampling frequency (FS2-0 bits) if PLL mode is used.
- (2) Set up the ALC2 Enable/Disable(ALC2 bit)
- (3) Set up the digital volume(Addr : 0CH and 0DH)

At DATTC bit = "1"(default), ATTL7-0 bits of Address 0CH control both Lch and Rch attenuation level.

- (4) Power up of DAC and Speaker-amp : PMDAC bit = PMSPK bit = "0" → "1"
The initializing time of Speaker-amp is 2048/fs=46.4ms@fs=44.1kHz.
- (5) Exit the power-save-mode of Speaker-amp : SPPS bit = "0" → "1"
- (6) Enter the power-save-mode of Speaker-amp : SPPS bit = "1" → "0"
- (7) Power down DAC and Speaker-amp : PMDAC bit = PMSPK bit = "1" → "0"

■ Stop of Clock

MCLK can be stopped when PMMIC=PMADC=PMDAC=PMSPK= “0”.

1. When X’tal is used in PLL mode

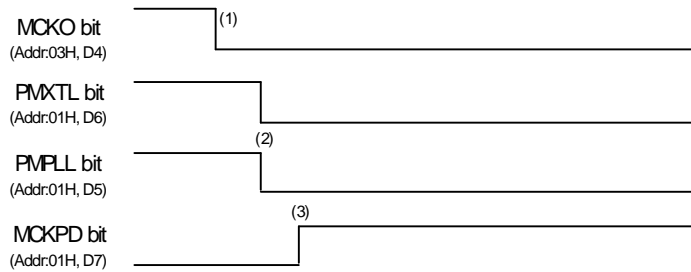

Example :
 Audio I/F Format : I²S
 BICK frequency at Master Mode : 64fs
 Input Master Clock Select at PLL Mode : 11.2896MHz
 Output Master Clock Frequency : 64fs

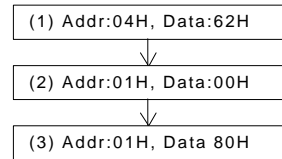
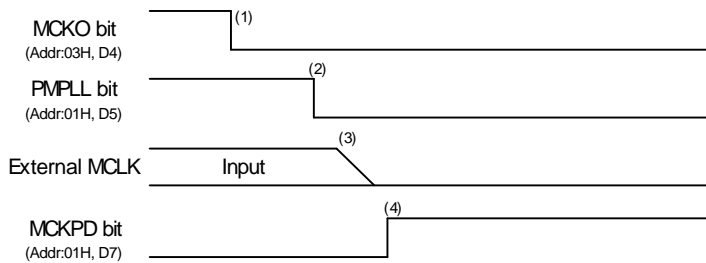

Figure 53. Stop of Clock Sequence(1)

<Example>

- (1) Disable MCKO output : MCKO bit = “1” → “0”
- (2) Power down X’tal and PLL : PMXTL bit = PMPLL bit = “1” → “0”
- (3) Pull down the XTI pin : MCKPD = “0” → “1”

2. When an external clock is used in PLL mode



Example :
 Audio I/F : I²S
 BICK frequency at Master Mode : 64fs
 Input Master Clock Select at PLL Mode : 11.2896MHz
 Output Master Clock Frequency : 64fs

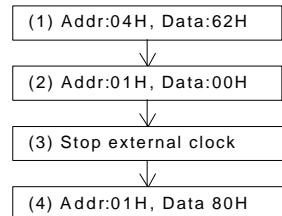

Figure 54. Stop of Clock Sequence(2)

<Example>

- (1) Stop MCKO output : MCKO bit = “1” → “0”
- (2) Power down PLL : PMPLL bit = “1” → “0”
- (3) Stop an external MCLK
- (4) Pull down the XTI pin : MCKPD = “0” → “1”

When the external MCLK becomes Hi-Z or the external MCLK is input by AC couple, MCKI pin should be pulled down.

3. External clock mode

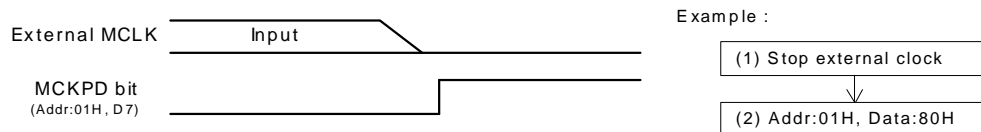

Figure 55. Stop of Clock Sequence(3)

<Example>

- (1) Stop an external MCLK
- (2) Pull down the XTI pin : MCKPD = “0” → “1”

When the external MCLK becomes Hi-Z or the external MCLK is input by AC couple, MCKI pin should be pulled down.

■ Power down

Power down VCOM(PMVCM= “1” → “0”) after all blocks except VCOM are powered down and MCLK stops. The AK4538 is also powered-down by PDN pin = “L”. When PDN pin = “L”, the registers are initialized.

PACKAGE

52pin QFN (Unit: mm)

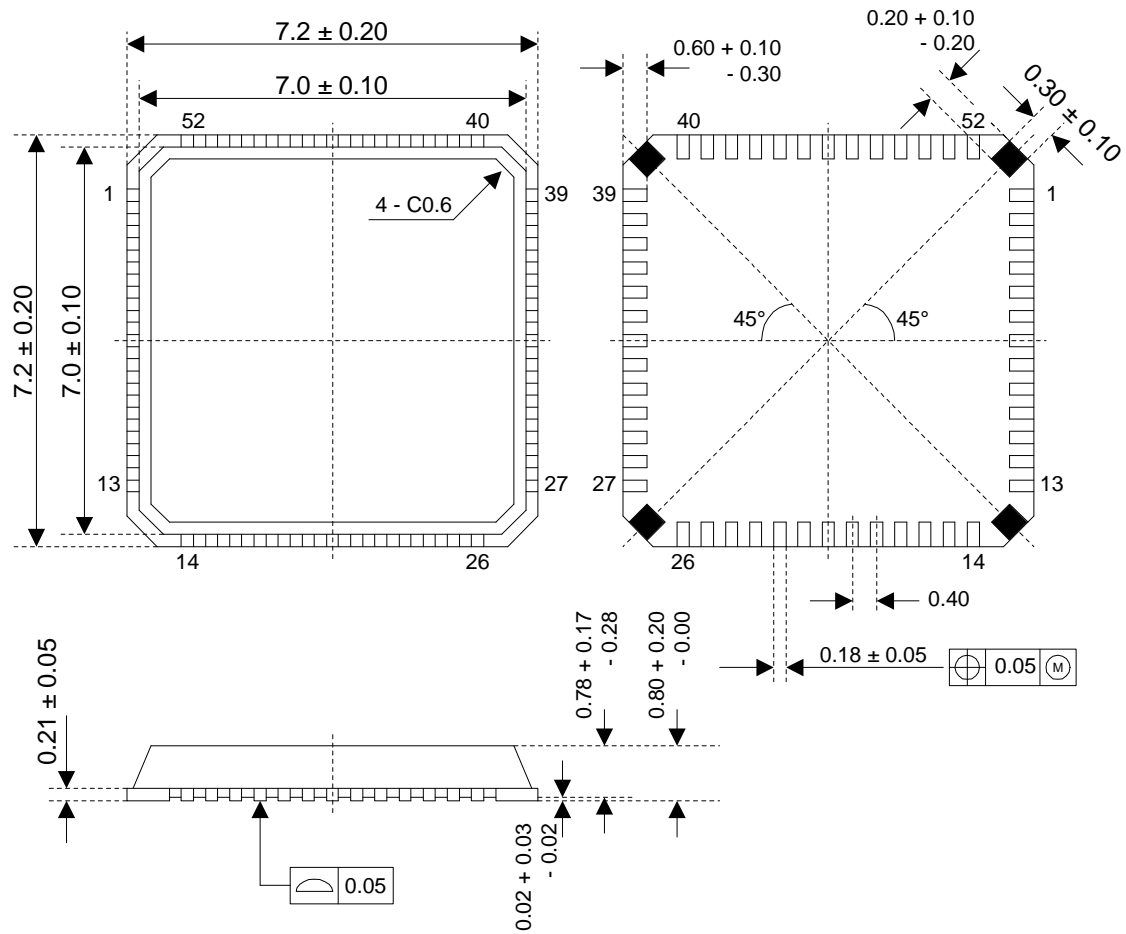

Note) The part of black at four corners on reverse side must not be soldered and must be open.

■ **Material & Lead finish**

| | |
|-------------------------------|------------------------|
| Package molding compound: | Epoxy |
| Lead frame material: | Cu |
| Lead frame surface treatment: | Solder plate (Pb free) |

| |
|----------------|
| MARKING |
|----------------|

■ 52pin QFN

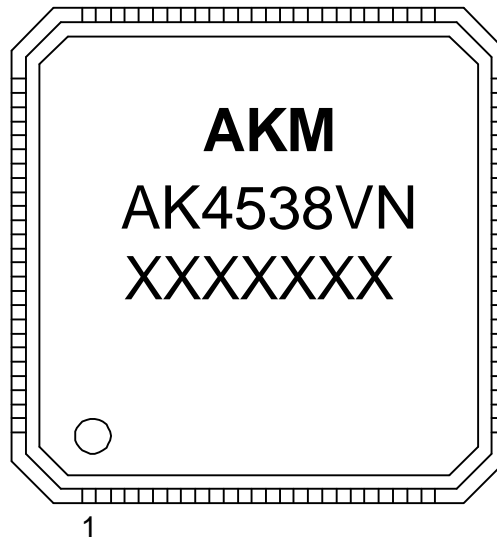

XXXXXXX : Date code identifier (7 digits)

IMPORTANT NOTICE

- These products and their specifications are subject to change without notice. Before considering any use or application, consult the Asahi Kasei Microsystems Co., Ltd. (AKM) sales office or authorized distributor concerning their current status.
- AKM assumes no liability for infringement of any patent, intellectual property, or other right in the application or use of any information contained herein.
- Any export of these products, or devices or systems containing them, may require an export license or other official approval under the law and regulations of the country of export pertaining to customs and tariffs, currency exchange, or strategic materials.
- AKM products are neither intended nor authorized for use as critical components in any safety, life support, or other hazard related device or system, and AKM assumes no responsibility relating to any such use, except with the express written consent of the Representative Director of AKM. As used here:
 - a. A hazard related device or system is one designed or intended for life support or maintenance of safety or for applications in medicine, aerospace, nuclear energy, or other fields, in which its failure to function or perform may reasonably be expected to result in loss of life or in significant injury or damage to person or property.
 - b. A critical component is one whose failure to function or perform may reasonably be expected to result, whether directly or indirectly, in the loss of the safety or effectiveness of the device or system containing it, and which must therefore meet very high standards of performance and reliability.
- It is the responsibility of the buyer or distributor of an AKM product who distributes, disposes of, or otherwise places the product with a third party to notify that party in advance of the above content and conditions, and the buyer or distributor agrees to assume any and all responsibility and liability for and hold AKM harmless from any and all claims arising from the use of said product in the absence of such notification.