

AN7531SA

Headphone amplifier IC for portable equipment

Overview

AN7531SA is an audio signal processing IC in which bass boost amplifiers, ALC circuit and beep circuit are built in the headphone amplifiers for use in portable equipment. Its headphone output block is using the center amplifier method which eliminates the need for coupling capacitor so that the circuit is most suitable for rationalization of audio circuit.

Features

- Output coupling capacitor is not required (Center amplifier method)
- Built-in bass boost amplifiers
- ALC circuit
- Built-in mute circuit
- Built-in beep circuit
- With mixed output pin of power amplifier

Applications

- Portable CD and MD players, etc.

Block Diagram

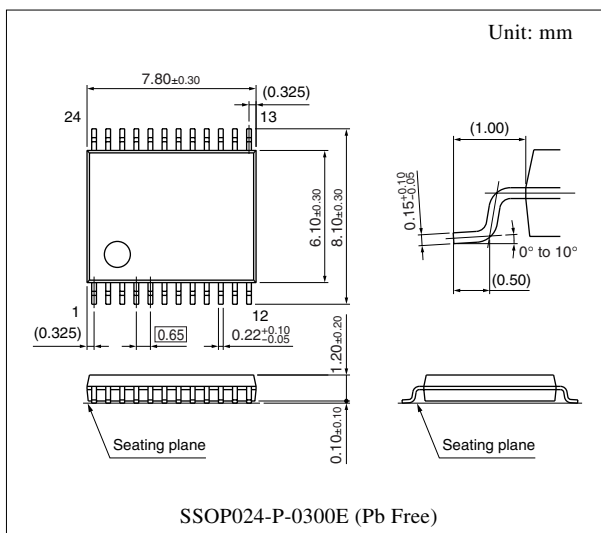
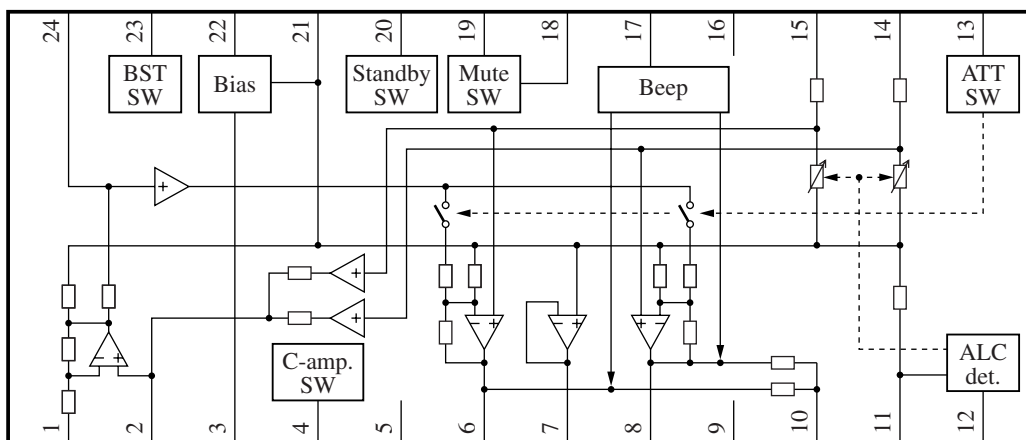

■ Pin Descriptions

Pin No.	Description	Pin No.	Description
1	Bass boost amplifier NF	13	Attenuation SW
2	ch.1 and ch.2-mixed output pin	14	ch.1 input pin
3	Ripple filter	15	ch.2 input pin
4	Center amplifier output control SW	16	GND (input)
5	Supply pin	17	Beep sound input pin
6	ch.2 output pin	18	Mute time-constant pin
7	Center amplifier output pin	19	Mute control pin
8	ch.1 output pin	20	Standby control pin
9	GND (output)	21	Bias output pin
10	Mixed output pin of power amplifier	22	Bias input pin
11	ALC input pin	23	Bass boost control pin
12	ALC detection pin	24	Bass boost amplifier output pin

■ Absolute Maximum Ratings

Parameter	Symbol	Rating	Unit
Supply voltage *2	V_{CC}	4.6	V
Supply current	I_{CC}	200	mA
Power dissipation *3	P_D	370	mW
Operating ambient temperature *1	T_{opr}	-25 to +75	°C
Storage temperature *1	T_{stg}	-55 to +125	°C

Note) *1: Except for the operating ambient temperature and storage temperature, all ratings are for $T_a = 25^\circ\text{C}$.

*2: Without signal.

*3: $T_a = 75^\circ\text{C}$, mounted on standard board (Refer to the Application Notes).

■ Recommended Operating Range

Parameter	Symbol	Range	Unit
Supply voltage	V_{CC}	1.8 to 4.5	V

■ Electrical Characteristics at $T_a = 25^\circ\text{C}$

Parameter	Symbol	Conditions	Min	Typ	Max	Unit
Standby current	I_{STB}	$V_{\text{IN}} = 0 \text{ mV}$, STB: On	—	0.1	5	μA
Quiescent current 1	I_{CQ1}	$V_{\text{IN}} = 0 \text{ mV}$, C-CUP: On	—	1.5	3.0	mA
Quiescent current 2	I_{CQ2}	$V_{\text{IN}} = 0 \text{ mV}$, C-CUP: Off	—	2.0	4.0	mA
Voltage gain 1	G_{V1}	$V_{\text{OUT}} = -22 \text{ dBV}$, ATT: On	5.5	8.3	10.5	dB
Voltage gain 2	G_{V2}	$V_{\text{OUT}} = -22 \text{ dBV}$, ATT: Off	14	15.9	18	dB
Channel balance	CB	$V_{\text{OUT}} = -22 \text{ dBV}$	-1.0	0	1.0	dB
Maximum output power	P_{O}	THD = 10%, $V_{\text{CC}} = 2 \text{ V}$	5.0	9.0	—	mW
Total harmonic distortion	THD	$V_{\text{OUT}} = -12.2 \text{ dBV}$	—	0.1	0.5	%
Output noise voltage	V_{NO}	$R_{\text{g}} = 600 \Omega$	—	-94.5	-88	dBV
Channel cross-talk	CT	$V_{\text{OUT}} = -12.2 \text{ dBV}$	30	50	—	dB
Ripple rejection	RR	$V_{\text{CC}} = 1.8 \text{ V}$, $f_r = 100 \text{ Hz}$, $V_r = -20 \text{ dBV}$	64	72	—	dB
Mute attenuation	MT	$V_{\text{OUT}} = -12.2 \text{ dBV}$	68	78	—	dB
Beep sound output voltage	V_{BEEP}	$V_{\text{BEEP-IN}} = 0 \text{ dBV}$	-56	-51	-46	dBV
Boosting amount	B_{ST}	$V_{\text{OUT}} = -30 \text{ dBV}$, $f = 100 \text{ Hz}$	9.7	11.7	13.7	dB
ALC detection level	V_{ALC}	$V_{\text{IN}} = -20 \text{ dBV}$	-41.5	-39.5	-37.5	dBV

Note) Condition: $V_{\text{CC}} = 2.4 \text{ V}$, $R_{\text{L}} = 16 \Omega$, $f = 1 \text{ kHz}$, $R_{\text{g}} = 10 \text{ k}\Omega$, STB: On, Mute: Off, C-CUP: Off, ATT: Off, ALC: Off, BST: Off

*1: Measurement using A curve filter

*2: Measurement using 30 kHz LPF

■ Application Notes

1. $P_{\text{D}} - T_{\text{a}}$ curves of SSOP024-P-0300E

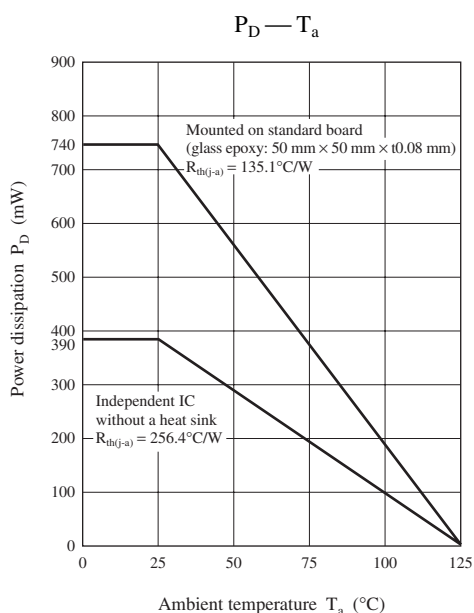

Application Notes (continued)

2. Main characteristics

$I_{CC} - V_{CC}$ (STB: 0 V, Mute: On)

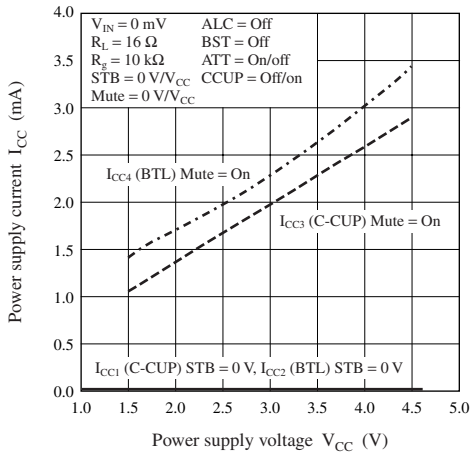

$I_{CC} - V_{CC}$

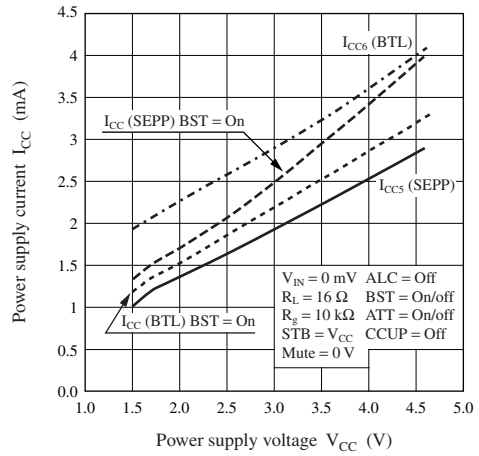

$I_{CC} - V_{CC}$ (ALC: On, ATT: On)

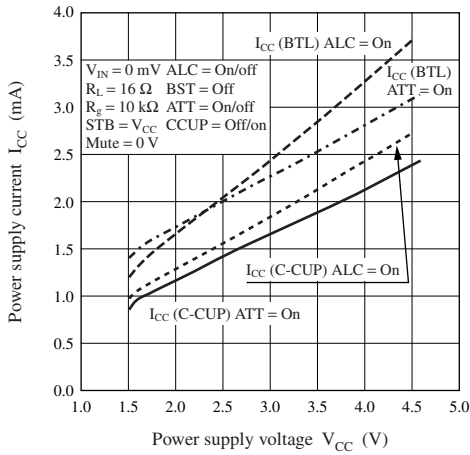

$I_{CC7,8} - V_{CC}$

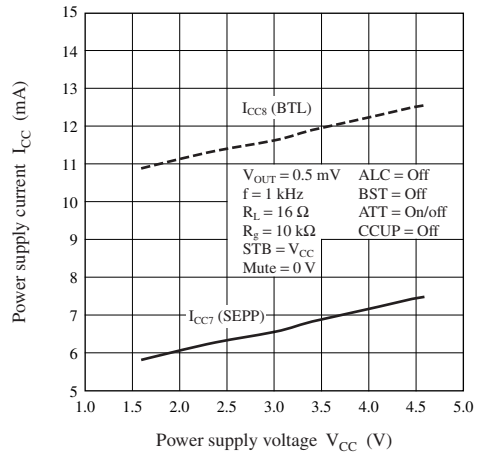

$I_{CC} - P_O$

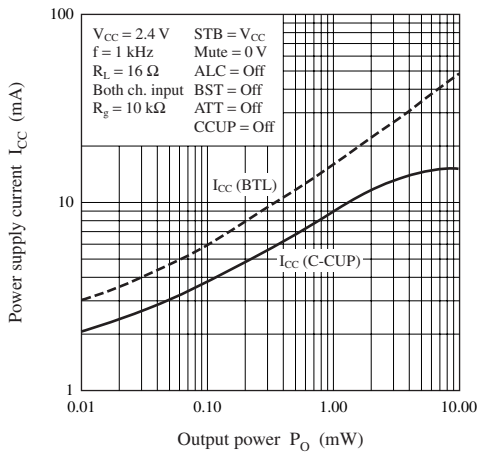

$I_{CQ} - V_{STB}$

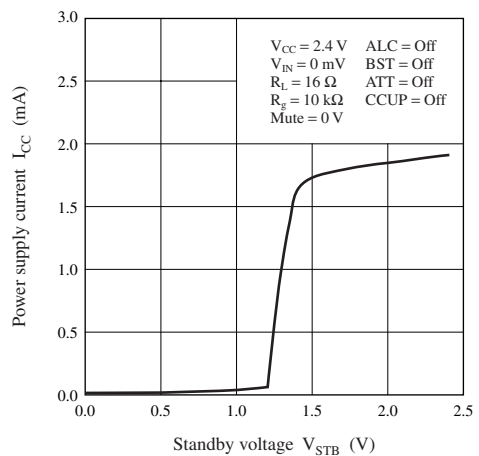

Application Notes (continued)

2. Main characteristics (continued)

$P_O - V_{CC}$

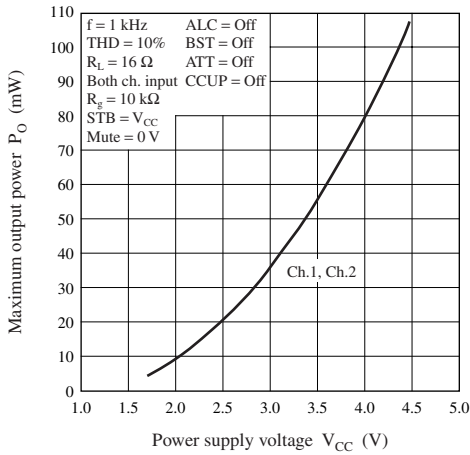

THD — P_O

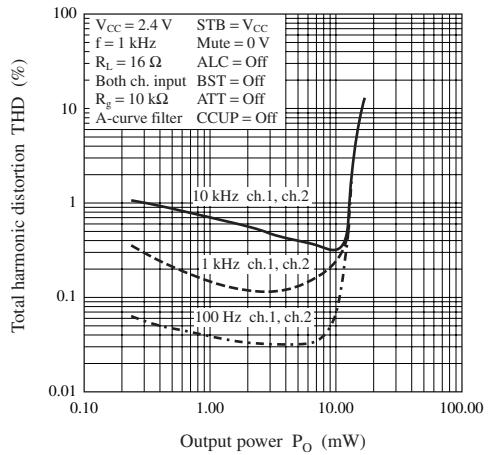

$P_O, THD - V_{IN}$ (ALC: On)

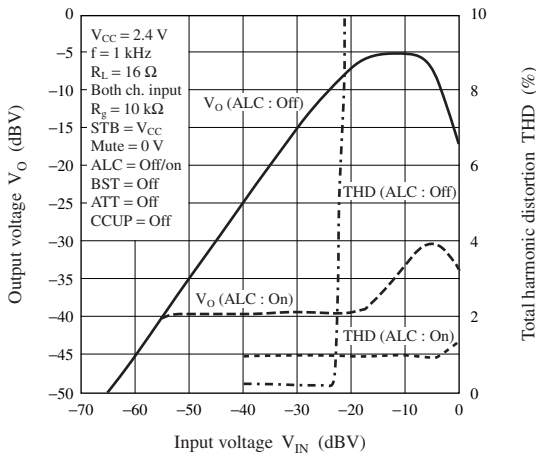

$G_V - \text{frequency}$

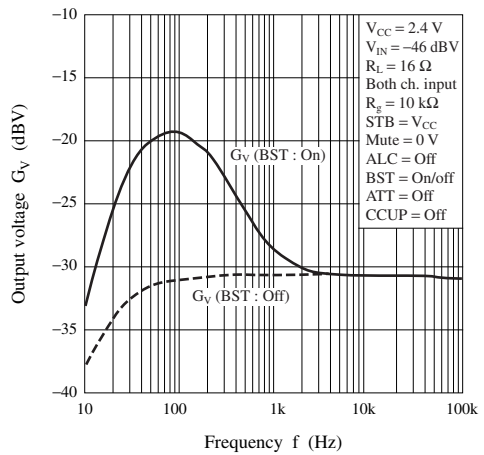

Beep — V_{IN}

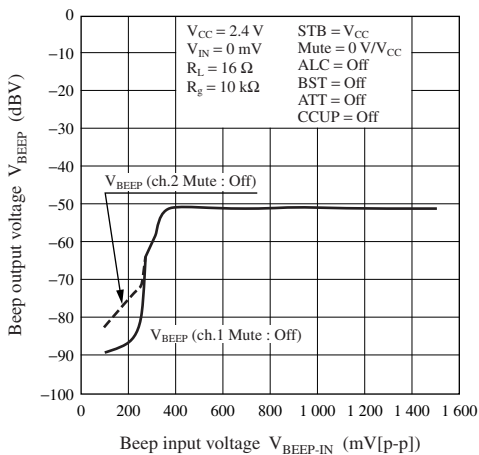

$G_V - V_{CC}$

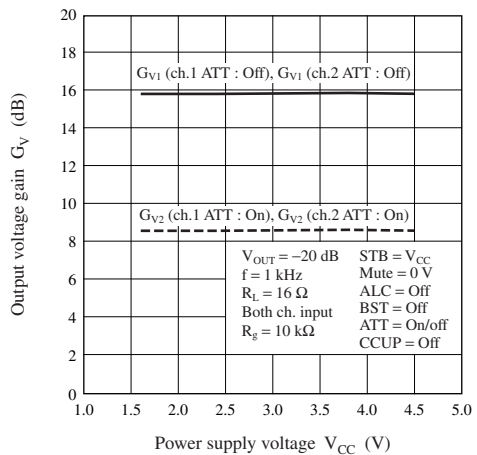

■ Application Notes (continued)

2. Main characteristics (continued)

CT, MT — frequency

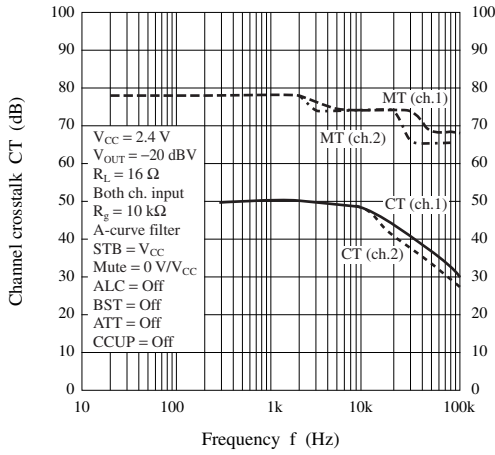

CT, MT — V_{IN}

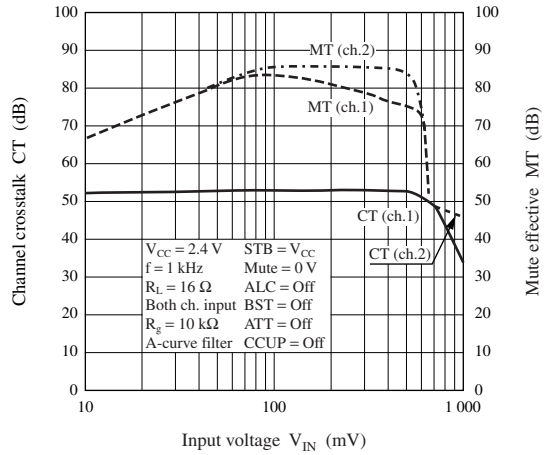

RR — V_{CC}

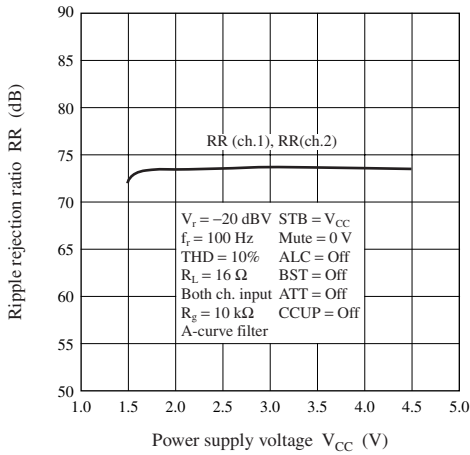

V_{TH-STB} — V_{CC}

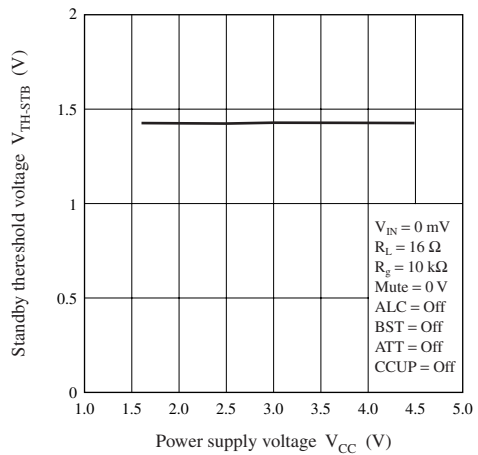

$V_{TH-MUTE}$ — V_{CC}

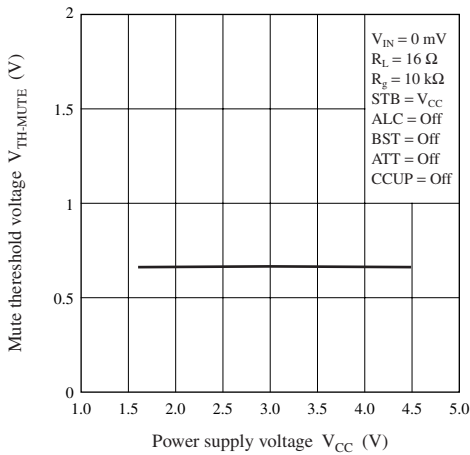

V_{TH-ALC} , V_{TH-BST} — V_{CC}

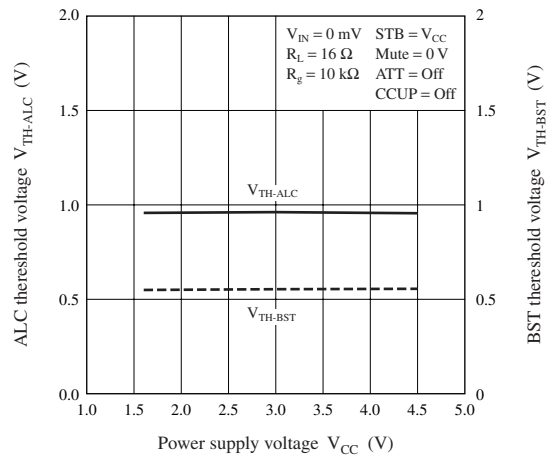

■ Application Notes (continued)

2. Main characteristics (continued)

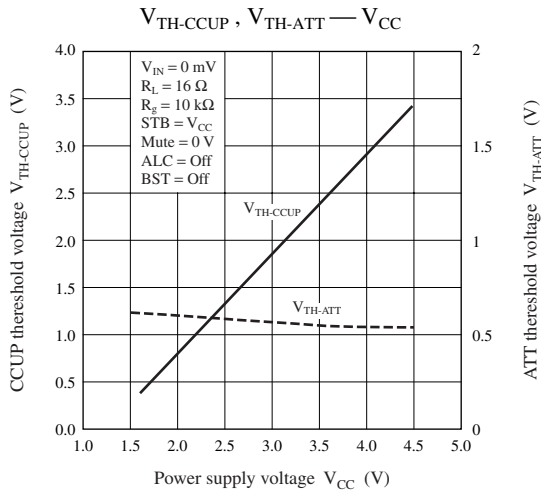

■ Application Circuit Examples

1. Center output method (without output capacitor)

1) At bass boosting

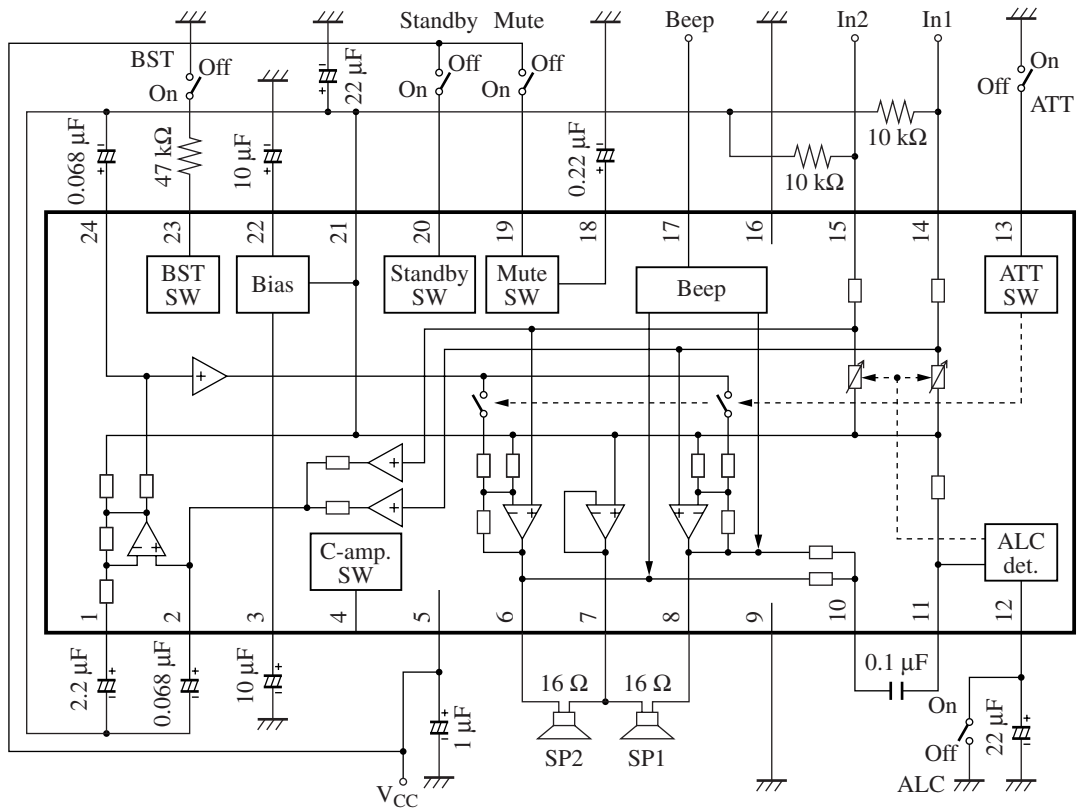

■ Application Circuit Examples (continued)

1. Center output method (without output capacitor) (continued)

2) No bass boosting

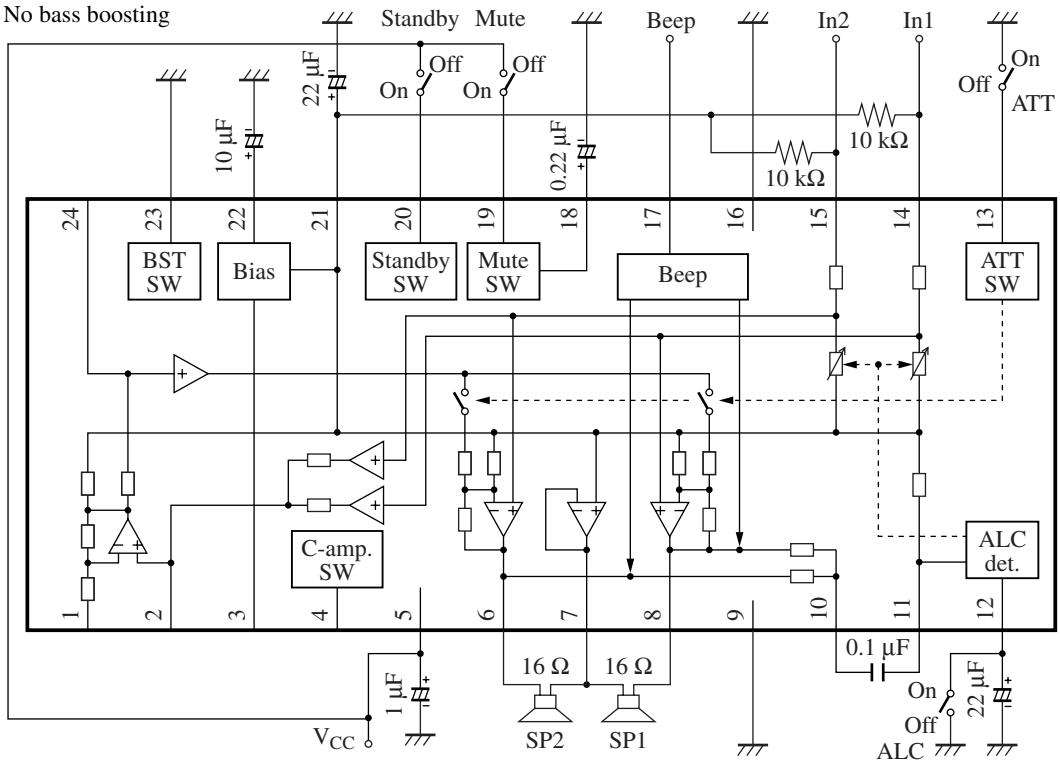

2. Output transformer less (OTL) (Output capacitors are necessary)

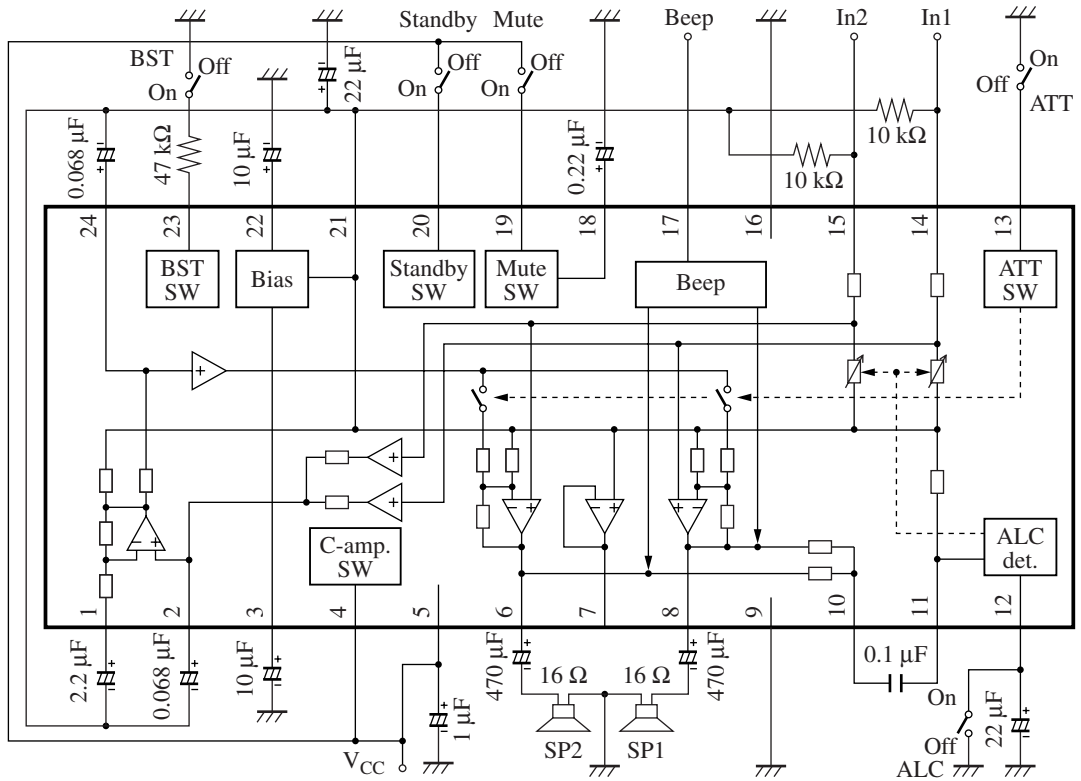

Request for your special attention and precautions in using the technical information and semiconductors described in this material

- (1) An export permit needs to be obtained from the competent authorities of the Japanese Government if any of the products or technologies described in this material and controlled under the "Foreign Exchange and Foreign Trade Law" is to be exported or taken out of Japan.
- (2) The technical information described in this material is limited to showing representative characteristics and applied circuit examples of the products. It does not constitute the warranting of industrial property, the granting of relative rights, or the granting of any license.
- (3) The products described in this material are intended to be used for standard applications or general electronic equipment (such as office equipment, communications equipment, measuring instruments and household appliances).
Consult our sales staff in advance for information on the following applications:
 - Special applications (such as for airplanes, aerospace, automobiles, traffic control equipment, combustion equipment, life support systems and safety devices) in which exceptional quality and reliability are required, or if the failure or malfunction of the products may directly jeopardize life or harm the human body.
 - Any applications other than the standard applications intended.
- (4) The products and product specifications described in this material are subject to change without notice for reasons of modification and/or improvement. At the final stage of your design, purchasing, or use of the products, therefore, ask for the most up-to-date Product Standards in advance to make sure that the latest specifications satisfy your requirements.
- (5) When designing your equipment, comply with the guaranteed values, in particular those of maximum rating, the range of operating power supply voltage and heat radiation characteristics. Otherwise, we will not be liable for any defect which may arise later in your equipment.
Even when the products are used within the guaranteed values, redundant design is recommended, so that such equipment may not violate relevant laws or regulations because of the function of our products.
- (6) When using products for which dry packing is required, observe the conditions (including shelf life and after-unpacking standby time) agreed upon when specification sheets are individually exchanged.
- (7) No part of this material may be reprinted or reproduced by any means without written permission from our company.

Please read the following notes before using the datasheets

- A. These materials are intended as a reference to assist customers with the selection of Panasonic semiconductor products best suited to their applications.
Due to modification or other reasons, any information contained in this material, such as available product types, technical data, and so on, is subject to change without notice.
Customers are advised to contact our semiconductor sales office and obtain the latest information before starting precise technical research and/or purchasing activities.
- B. Panasonic is endeavoring to continually improve the quality and reliability of these materials but there is always the possibility that further rectifications will be required in the future. Therefore, Panasonic will not assume any liability for any damages arising from any errors etc. that may appear in this material.
- C. These materials are solely intended for a customer's individual use.
Therefore, without the prior written approval of Panasonic, any other use such as reproducing, selling, or distributing this material to a third party, via the Internet or in any other way, is prohibited.