

International
IR Rectifier
HEXFRED™

PD-91797

PRELIMINARY **HFA40HF120C**
Ultrafast, Soft Recovery Diode

Features

- Reduced RFI and EMI
- Reduced Snubbing
- Extensive Characterization of Recovery Parameters
- Hermetic
- Surface Mount

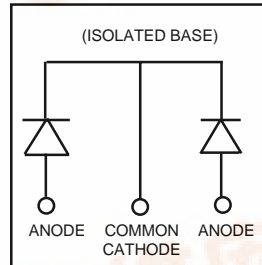

$V_R = 1200V$
$V_F = 4.46V$
$Q_{rr} = 370nC$
$di_{(rec)}/dt = 380A/\mu s$

Description

HEXFRED™ diodes are optimized to reduce losses and EMI/RFI in high frequency power conditioning systems. An extensive characterization of the recovery behavior for different values of current, temperature and di/dt simplifies the calculations of losses in the operating conditions. The softness of the recovery eliminates the need for a snubber in most applications. These devices are ideally suited for power converters, motors drives and other applications where switching losses are significant portion of the total losses.

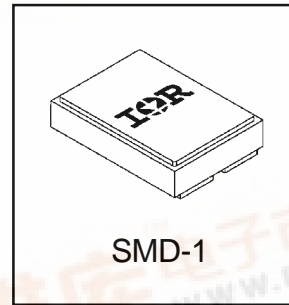

Absolute Maximum Ratings (per Leg)

	Parameter	Max.	Units
V_R	D.C. Reverse Voltage	1200	V
$I_F @ T_C = 100^\circ C$	Continuous Forward Current ①	15	A
$I_{FSM} @ T_C = 25^\circ C$	Single Pulse Forward Current ②	130	
$P_D @ T_C = 25^\circ C$	Maximum Power Dissipation	63	W
T_J	Operating Junction and	-55 to +150	°C
T_{STG}	Storage Temperature Range		

Thermal - Mechanical Characteristics

	Parameter	Typ.	Max.	Units
$R_{\theta JC}$	Junction-to-Case, Single Leg Conducting	—	2.0	°C/W
	Weight	2.6	—	g

Note: ① D.C. = 50% rect. wave
② 1/2 sine wave, 60 Hz, P.W. = 8.33 ms

www.irf.com



HFA40HF120C

International
IR Rectifier

Electrical Characteristics (per Leg) @ $T_J = 25^\circ\text{C}$ (unless otherwise specified)

	Parameter	Min.	Typ.	Max.	Units	Test Conditions
V_{BR}	Cathode Anode Breakdown Voltage	1200	—	—	V	$I_R = 250\mu\text{A}$
V_{FM}	Max Forward Voltage	—	—	3.3	V	$I_F = 7.0\text{A}$
		—	—	4.4		$I_F = 15\text{A}$ See Fig. 1
		—	—	2.8		$I_F = 7.0\text{A}, T_J = 125^\circ\text{C}$
I_{RM}	Max Reverse Leakage Current	—	—	10	μA	$V_R = V_R$ Rated See Fig. 2
		—	—	1.0	mA	$T_J = 125^\circ\text{C}, V_R = 480\text{V}$
C_T	Junction Capacitance	—	10	15	pF	$V_R = 200\text{V}$ See Fig. 3
L_S	Series Inductance	—	2.8	—	nH	Measured from center of bond pad to end of anode bonding wire

Dynamic Recovery Characteristics (per Leg) @ $T_J = 25^\circ\text{C}$ (unless otherwise specified)

	Parameter	Min.	Typ.	Max.	Units	Test Conditions
t_{rr1}	Reverse Recovery Time	—	58	100	ns	$T_J = 25^\circ\text{C}$ See Fig. 5
t_{rr2}		—	110	165		$T_J = 125^\circ\text{C}$
I_{RRM1}	Peak Recovery Current	—	5.4	8.1	A	$T_J = 25^\circ\text{C}$ See Fig. 6
I_{RRM2}		—	7.2	10.8		$T_J = 125^\circ\text{C}$
Q_{rr1}	Reverse Recovery Charge	—	185	370	nC	$T_J = 25^\circ\text{C}$ See Fig. 7
Q_{rr2}		—	395	590		$T_J = 125^\circ\text{C}$
$di_{(rec)M}/dt1$	Peak Rate of Fall of Recovery Current During t_b	—	255	380	$\text{A}/\mu\text{s}$	$T_J = 25^\circ\text{C}$ See Fig. 8
$di_{(rec)M}/dt2$		—	160	240		$T_J = 125^\circ\text{C}$

Case Outline and Dimensions — SMD-1

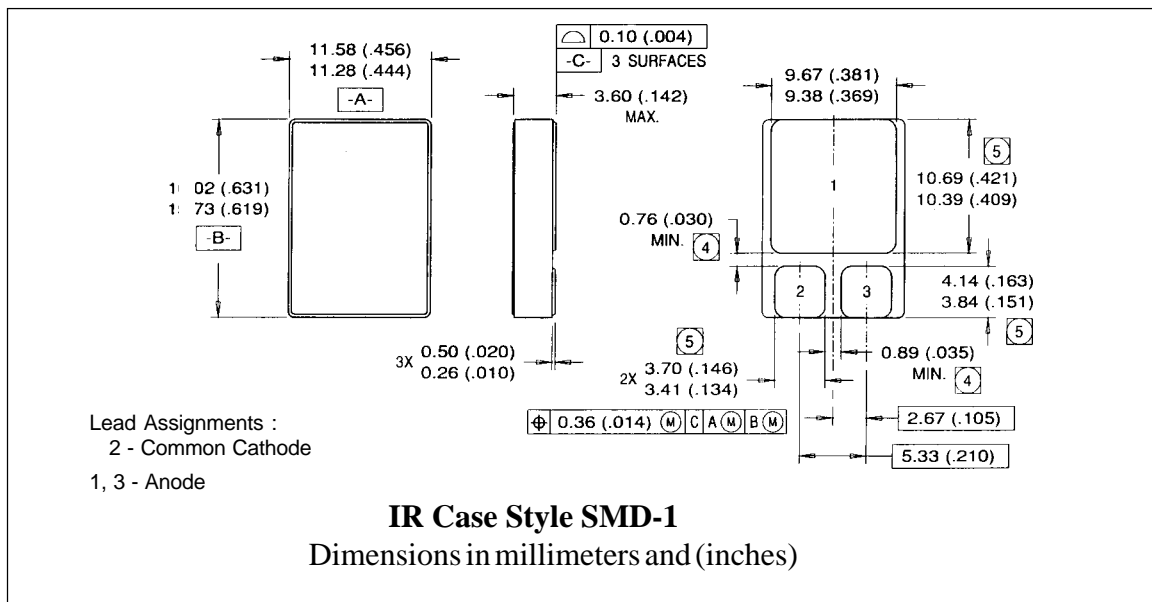

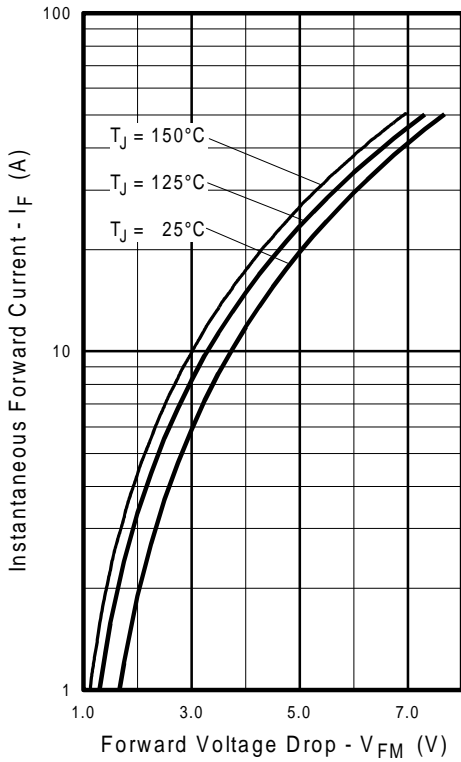

Fig. 1 - Maximum Forward Voltage Drop vs. Instantaneous Forward Current

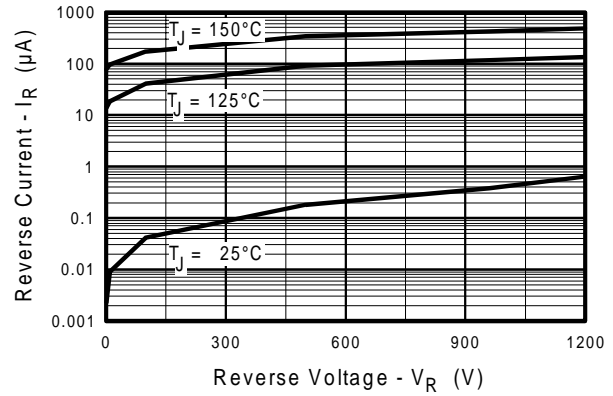

Fig. 2 - Typical Reverse Current vs. Reverse Voltage

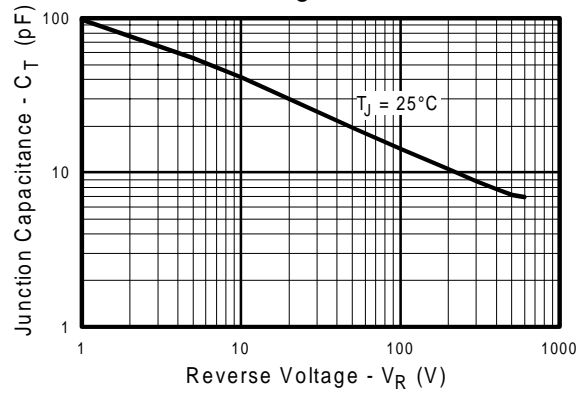

Fig. 3 - Typical Junction Capacitance vs. Reverse Voltage

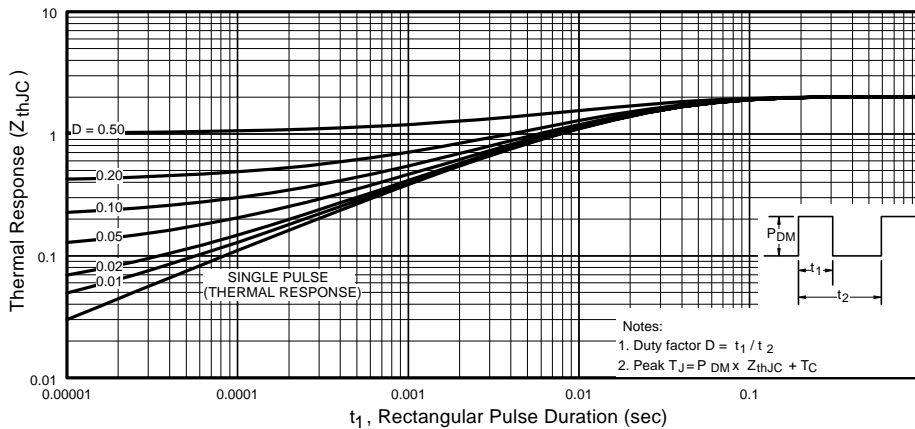

Fig. 4 - Maximum Thermal Impedance Z_{thjC} Characteristics

HFA40HF120C

International
IR Rectifier

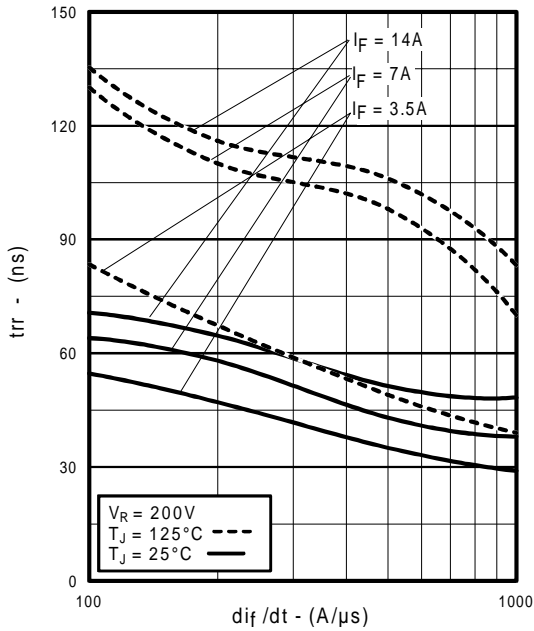

Fig. 5 - Typical Reverse Recovery vs. di_f/dt

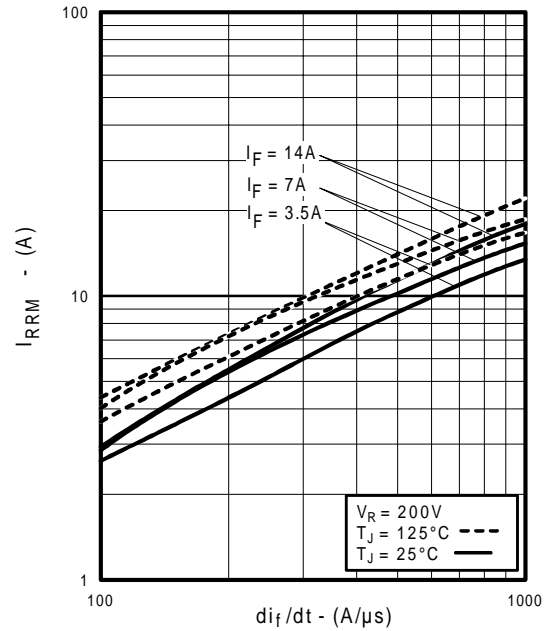

Fig. 6 - Typical Recovery Current vs. di_f/dt

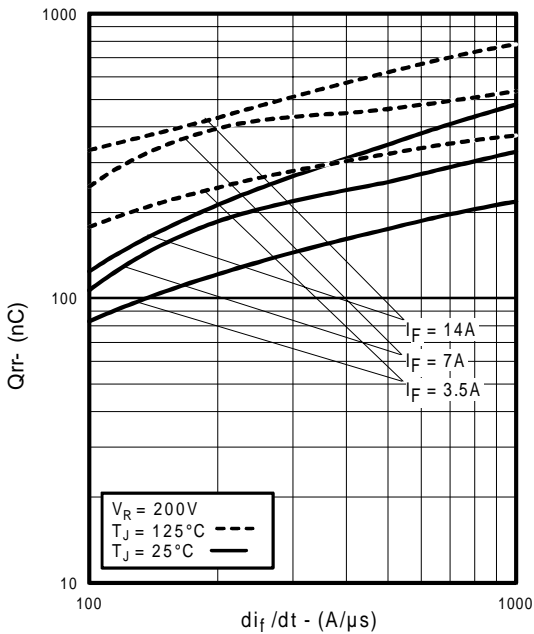

Fig. 7 - Typical Stored Charge vs. di_f/dt

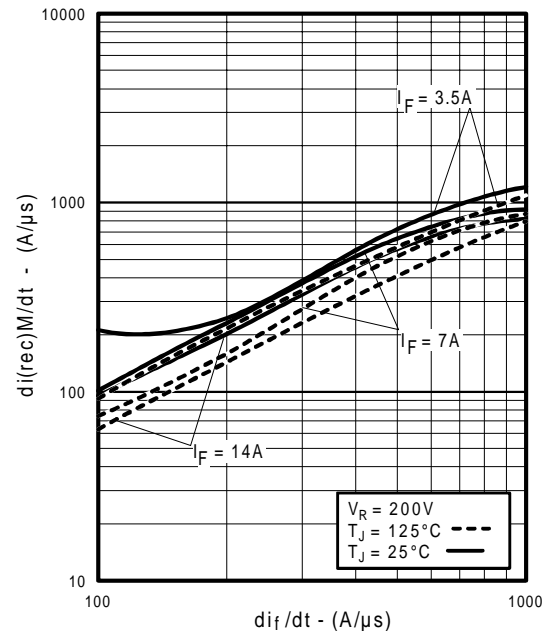

Fig. 8 - Typical $di_{(rec)M}/dt$ vs. di_f/dt

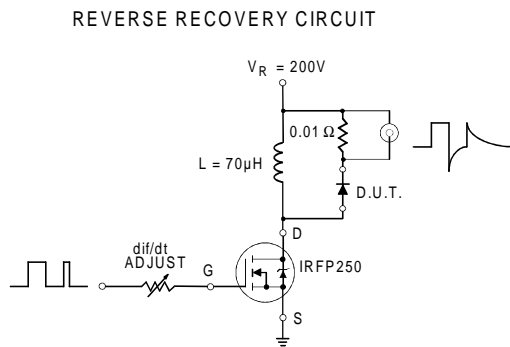

Fig. 9 - Reverse Recovery Parameter Test Circuit

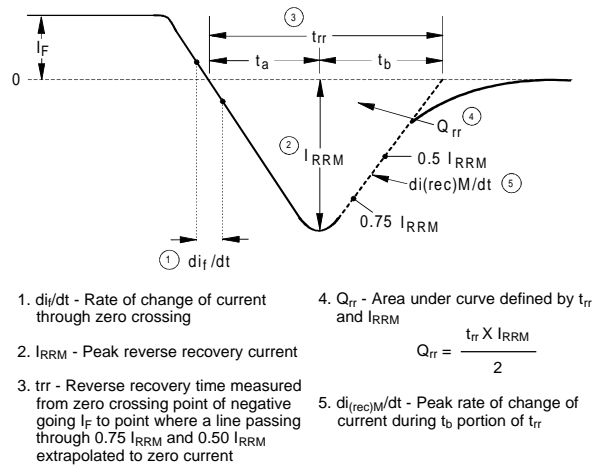

Fig. 10 - Reverse Recovery Waveform and Definitions