

International  
**IR** Rectifier  
HEXFRED™

PD-20380A

# HFA45HI60C

Ultrafast, Soft Recovery Diode

### Features

- Reduced RFI and EMI
- Reduced Snubbing
- Extensive Characterization of Recovery Parameters
- Hermetic
- Electrically Isolated
- Ceramic Eyelets

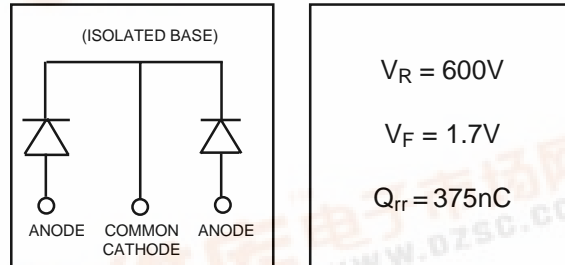

### Description

HEXFRED™ diodes are optimized to reduce losses and EMI/RFI in high frequency power conditioning systems. An extensive characterization of the recovery behavior for different values of current, temperature and di/dt simplifies the calculations of losses in the operating conditions. The softness of the recovery eliminates the need for a snubber in most applications. These devices are ideally suited for power converters, motors drives and other applications where switching losses are significant portion of the total losses.

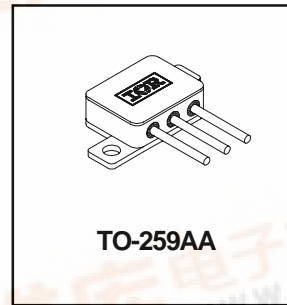

### Absolute Maximum Ratings (per Leg)

	Parameter	Max.	Units
$V_R$	D.C. Reverse Voltage	600	V
$I_F @ T_C = 100^\circ\text{C}$	Continuous Forward Current ①	45 *	A
$I_{FSM} @ T_C = 25^\circ\text{C}$	Single Pulse Forward Current ②	225	
$P_D @ T_C = 25^\circ\text{C}$	Maximum Power Dissipation	104	W
$T_J$	Operating Junction and	-55 to +150	°C
$T_{STG}$	Storage Temperature Range		

### Thermal - Mechanical Characteristics

	Parameter	Typ.	Max.	Units
$R_{\theta JC}$	Junction-to-Case, Single Leg Conducting	—	1.2	°C/W
	Weight	10.9	—	g

**Note:** ① D.C. = 50% rect. wave  
 ② 1/2 sine wave, 60 Hz, P.W. = 8.33 ms  
 \* Current is limited by pin diameter.



# HFA45HI60C

International  
**IRF** Rectifier

## Electrical Characteristics (per Leg) @ $T_J = 25^\circ\text{C}$ (unless otherwise specified)

	Parameter	Min.	Typ.	Max.	Units	Test Conditions
$V_{BR}$	Cathode Anode Breakdown Voltage	600	—	—	V	$I_R = 100\mu\text{A}$
$V_{FM}$	Max Forward Voltage	—	—	1.7	V	$I_F = 22\text{A}$
		—	—	2.0		$I_F = 45\text{A}$
		—	—	1.5		$I_F = 22\text{A}, T_J = 125^\circ\text{C}$
$I_{RM}$	Max Reverse Leakage Current	—	—	10	$\mu\text{A}$	$V_R = V_R$ Rated
		—	—	1.0	$\text{mA}$	$T_J = 125^\circ\text{C}, V_R = 480\text{V}$
$C_T$	Junction Capacitance	—	—	100	$\text{pF}$	$V_R = 200\text{V}$
$L_S$	Series Inductance	—	13	—	$\text{nH}$	Measured from center of bond pad to end of anode bonding wire

## Dynamic Recovery Characteristics (per Leg) @ $T_J = 25^\circ\text{C}$

	Parameter	Min.	Typ.	Max.	Units	Test Conditions
$t_{rr}$	Reverse Recovery Time	—	—	75	$\text{nS}$	$I_F = 22\text{A}, di/dt \leq 200\text{A}/\mu\text{s}, V_R = 200\text{V}$
$I_{RRM}$	Max Reverse Recovery Current	—	—	10	A	$I_F = 22\text{A}, di/dt \leq 200\text{A}/\mu\text{s}, V_R = 200\text{V}$
$Q_{RR}$	Reverse Recovered Charge	—	—	375	$\text{nC}$	$I_F = 22\text{A}, di/dt \leq 200\text{A}/\mu\text{s}, V_R = 200\text{V}$

## Case Outline and Dimensions — TO-259AA

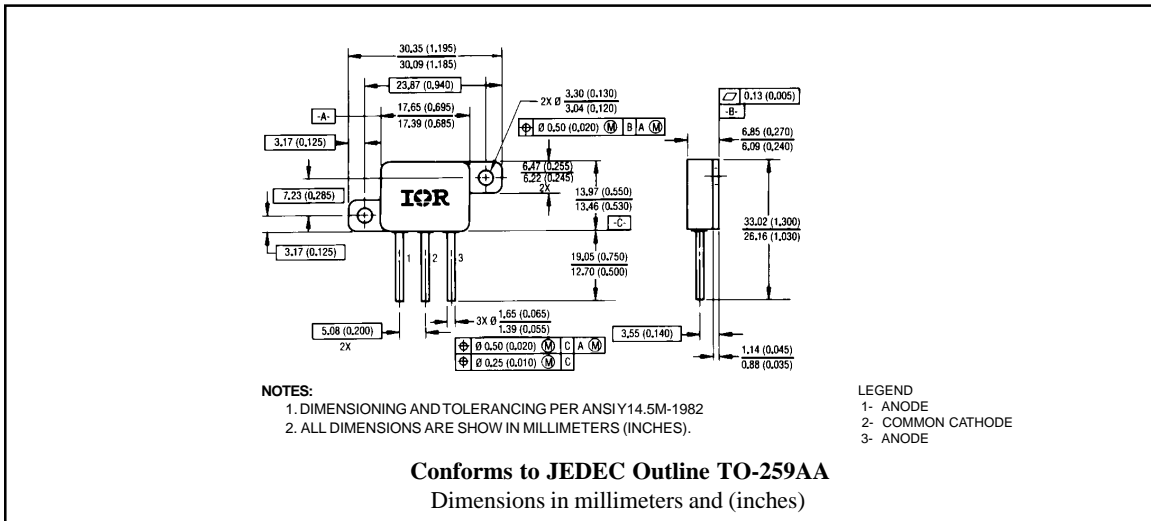

### CAUTION BERYLLIA WARNING PER MIL- PRF-19500

Package containing beryllia shall not be ground, sandblasted, machined, or have other operations performed on them which will produce beryllia or beryllium dust. Furthermore, beryllium oxide packages shall not be placed in acids that will produce fumes containing beryllium.

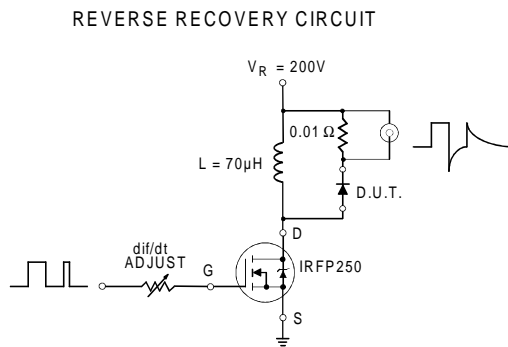

**Fig.1 - Reverse Recovery Parameter Test Circuit**

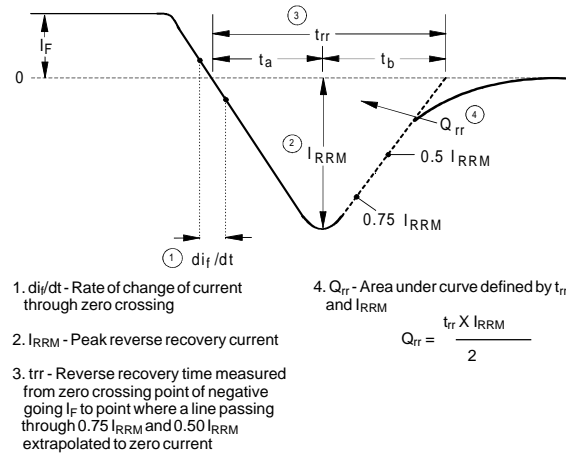

**Fig. 2 - Reverse Recovery Waveform and Definitions**