

International
IR Rectifier

PROVISIONAL

PD- 93924

SMPS MOSFET

IRFBA32N50K

HEXFET® Power MOSFET

Applications

- Telecom and Data-Com off-Line SMPS
- Uninterruptible Power Supply

Benefits

- Low On-Resistance
- High Speed Switching
- Low Gate Drive Current Due to Improved Gate Charge Characteristics
- Improved Avalanche Ruggedness and Dynamic dv/dt, Fully Characterized Avalanche Voltage and Current

V_{DSS}	R_{DS(on)}	I_D
500V	0.14Ω	32A



Absolute Maximum Ratings

	Parameter	Max.	Units
I _D @ T _C = 25°C	Continuous Drain Current, V _{GS} @ 10V	32	A
I _D @ T _C = 100°C	Continuous Drain Current, V _{GS} @ 10V	20	
I _{DM}	Pulsed Drain Current ①	128	
P _D @ T _C = 25°C	Power Dissipation	360	W
	Linear Derating Factor	2.9	W/°C
V _{GS}	Gate-to-Source Voltage	± 30	V
dv/dt	Peak Diode Recovery dv/dt ③	5.0	V/ns
T _J	Operating Junction and	-55 to + 150	°C
T _{STG}	Storage Temperature Range		
	Soldering Temperature, for 10 seconds (1.6mm from case)	300	
	Recommended clip force	20	N

Diode Characteristics

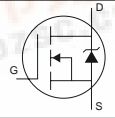
Symbol	Parameter	Min.	Typ.	Max.	Units	Conditions
I _S	Continuous Source Current (Body Diode)	—	—	32	A	MOSFET symbol showing the integral reverse p-n junction diode. 
I _{SM}	Pulsed Source Current (Body Diode) ①	—	—	128		
V _{SD}	Diode Forward Voltage	—	—	1.5	V	T _J = 25°C, I _S = 32A, V _{GS} = 0V ④
t _{rr}	Reverse Recovery Time	—	650	—	ns	T _J = 125°C, I _F = 32A
Q _{rr}	Reverse Recovery Charge	—	9.0	—	μC	di/dt = 100A/μs ④
t _{on}	Forward Turn-On Time	Intrinsic turn-on time is negligible (turn-on is dominated by L _S +L _D)				

Typical SMPS Topologies

- Hard Switching Full and Half Bridge Circuits
- Hard Switching Single Transistor Circuits
- Power Factor Correction Circuits

www.irf.com



IRFBA32N50K

PROVISIONAL

International
IR Rectifier

Static @ $T_J = 25^\circ\text{C}$ (unless otherwise specified)

Symbol	Parameter	Min.	Typ.	Max.	Units	Conditions
$V_{(BR)DSS}$	Drain-to-Source Breakdown Voltage	500	—	—	V	$V_{GS} = 0V, I_D = 250\mu A$
$\Delta V_{(BR)DSS}/\Delta T_J$	Breakdown Voltage Temp. Coefficient	—	0.55	—	V/°C	Reference to $25^\circ\text{C}, I_D = 1\text{mA}$ ⑥
$R_{DS(on)}$	Static Drain-to-Source On-Resistance	—	—	0.14	Ω	$V_{GS} = 10V, I_D = 19A$ ④
$V_{GS(th)}$	Gate Threshold Voltage	3.5	—	5.5	V	$V_{DS} = V_{GS}, I_D = 250\mu A$
I_{DSS}	Drain-to-Source Leakage Current	—	—	50	μA	$V_{DS} = 500V, V_{GS} = 0V$
		—	—	250	μA	$V_{DS} = 400V, V_{GS} = 0V, T_J = 125^\circ\text{C}$
I_{GSS}	Gate-to-Source Forward Leakage	—	—	100	nA	$V_{GS} = 30V$
	Gate-to-Source Reverse Leakage	—	—	-100		$V_{GS} = -30V$

Dynamic @ $T_J = 25^\circ\text{C}$ (unless otherwise specified)

Symbol	Parameter	Min.	Typ.	Max.	Units	Conditions
g_{fs}	Forward Transconductance	12	—	—	S	$V_{DS} = 50V, I_D = 19A$
Q_g	Total Gate Charge	—	—	195	nC	$I_D = 32A$ $V_{DS} = 400V$ $V_{GS} = 10V, \text{④}$
Q_{gs}	Gate-to-Source Charge	—	—	75		
Q_{gd}	Gate-to-Drain ("Miller") Charge	—	—	90		
$t_{d(on)}$	Turn-On Delay Time	—	20	—	ns	$V_{DD} = 250V$ $I_D = 32A$ $R_G = 4.3\Omega$ $V_{GS} = 10V, \text{④}$
t_r	Rise Time	—	60	—		
$t_{d(off)}$	Turn-Off Delay Time	—	45	—		
t_f	Fall Time	—	40	—		
C_{iss}	Input Capacitance	—	5300	—	pF	$V_{GS} = 0V$ $V_{DS} = 25V$ $f = 1.0\text{MHz}$
C_{oss}	Output Capacitance	—	540	—		
C_{rss}	Reverse Transfer Capacitance	—	33	—		

Avalanche Characteristics

Symbol	Parameter	Typ.	Max.	Units
E_{AS}	Single Pulse Avalanche Energy②	—	760	mJ
I_{AR}	Avalanche Current①	—	32	A
E_{AR}	Repetitive Avalanche Energy①	—	36	mJ

Thermal Resistance

Symbol	Parameter	Typ.	Max.	Units
$R_{\theta JC}$	Junction-to-Case	—	0.35	°C/W
$R_{\theta CS}$	Case-to-Sink, Flat, Greased Surface	0.50	—	
$R_{\theta JA}$	Junction-to-Ambient	—	58	

Notes:

- ① Repetitive rating; pulse width limited by max. junction temperature. ④ Pulse width $\leq 400\mu s$; duty cycle $\leq 2\%$.
- ② Starting $T_J = 25^\circ\text{C}$, $L = 4.3\text{mH}$, $R_G = 25\Omega$,
 $I_{AS} = 32A$,
- ③ $I_{SD} \leq 32A$, $di/dt \leq TBDA/\mu s$, $V_{DD} \leq V_{(BR)DSS}$,
 $T_J \leq 150^\circ\text{C}$

Super-220™ Package Outline

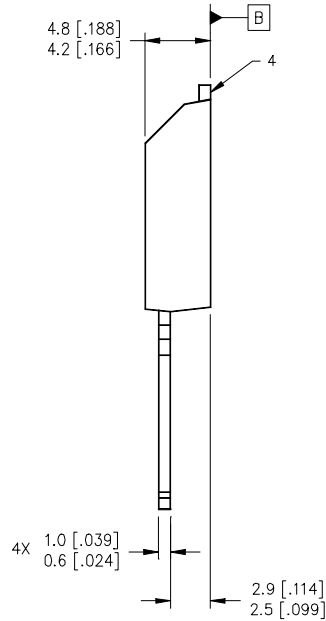
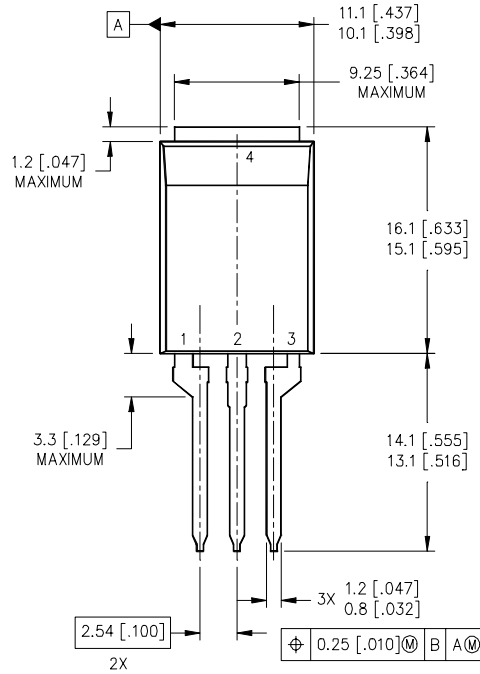

NOTES:

1. DIMENSIONING & TOLERANCING PER ASME Y14.5M-1994.
2. CONTROLLING DIMENSION: MILLIMETER.
3. DIMENSIONS ARE SHOWN IN MILLIMETERS [INCHES].
4. OUTLINE CONFORMS TO JEDEC OUTLINE TO-273AA.

LEAD ASSIGNMENTS

MOSFET	IGBT
1 - GATE	1 - GATE
2 - DRAIN	2 - COLLECTOR
3 - SOURCE	3 - EMITTER
4 - DRAIN	4 - COLLECTOR