

International IR Rectifier

PD -94305D

IRG4MC40U

INSULATED GATE BIPOLAR TRANSISTOR

UltraFast Speed IGBT

Features

- Electrically Isolated and Hermetically Sealed
- Simple Drive Requirements
- Latch-proof
- UltraFast Speed Operation 8kHz - 40kHz, > 200kHz in Resonant Mode
- High Operating Frequency
- Switching-loss Rating includes all "tail" Losses
- Ceramic Eyelets

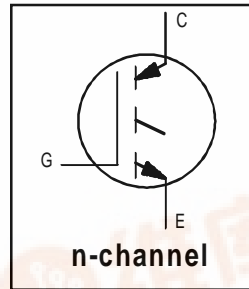

$V_{CES} = 600V$
$V_{CE(on) max} = 2.1V$
@ $V_{GE} = 15V, I_C = 20A$

Benefits

- Generation 4 IGBT's offer highest efficiency available
- IGBT's optimized for specified application conditions
- Designed to be a "drop-in" replacement for equivalent IR Hi-Rel Generation 3 IGBT's

Insulated Gate Bipolar Transistors (IGBTs) from International Rectifier have higher usable current densities than comparable bipolar transistors, while at the same time having simpler gate-drive requirements of the familiar power MOSFET. They provide substantial benefits to a host of high-voltage, high-current applications.



Absolute Maximum Ratings

	Parameter	Max.	Units
V_{CES}	Collector-to-Emitter Breakdown Voltage	600	V
$I_C @ T_C = 25^\circ C$	Continuous Collector Current	35*	A
$I_C @ T_C = 100^\circ C$	Continuous Collector Current	20	
I_{CM}	Pulsed Collector Current ①	140	
I_{LM}	Clamped Inductive Load Current ②	140	
V_{GE}	Gate-to-Emitter Voltage	± 20	V
$P_D @ T_C = 25^\circ C$	Maximum Power Dissipation	125	W
$P_D @ T_C = 100^\circ C$	Maximum Power Dissipation	50	
T_J	Operating Junction and Storage Temperature Range	-55 to + 150	$^\circ C$
T_{STG}			
	Lead Temperature	300 (0.063in./1.6mm from case for 10s)	
	Weight	9.3 (typical)	g

Thermal Resistance

	Parameter	Min	Typ	Max	Units	Test Conditions
R_{thJC}	Junction-to-Case	—	—	1.1	$^\circ C/W$	



IRG4MC40U

International
IR Rectifier

Electrical Characteristics @ $T_J = 25^\circ\text{C}$ (unless otherwise specified)

	Parameter	Min.	Typ.	Max.	Units	Conditions
$V_{(BR)CES}$	Collector-to-Emitter Breakdown Voltage	600	—	—	V	$V_{GE} = 0V, I_C = 1.0 \text{ mA}$
$V_{(BR)ECS}$	Emitter-to-Collector Breakdown Voltage ③	17	—	—	V	$V_{GE} = 0V, I_C = 1.0 \text{ A}$
$\Delta V_{(BR)CES}/\Delta T_J$	Temperature Coeff. of Breakdown Voltage	—	0.5	—	$V/^\circ\text{C}$	$V_{GE} = 0V, I_C = 1.0 \text{ mA}$
$V_{CE(ON)}$	Collector-to-Emitter Saturation Voltage	—	—	2.1	V	$I_C = 20A, V_{GE} = 15V$
		—	—	2.5		$I_C = 35A$ See Fig.2, 5
		—	—	2.0		$I_C = 20A, T_J = 125^\circ\text{C}$
$V_{GE(th)}$	Gate Threshold Voltage	3.0	—	6.0		$V_{CE} = V_{GE}, I_C = 1.0 \text{ mA}$
$\Delta V_{GE(th)}/\Delta T_J$	Temperature Coeff. of Threshold Voltage	—	-12	—	$\text{mV}/^\circ\text{C}$	$V_{CE} = V_{GE}, I_C = 250 \mu\text{A}$
g_{fe}	Forward Transconductance ④	11	—	—	S	$V_{CE} \geq 15V, I_C = 20A$
I_{CES}	Zero Gate Voltage Collector Current	—	—	50	μA	$V_{GE} = 0V, V_{CE} = 480V$
		—	—	2000		$V_{GE} = 0V, V_{CE} = 480V, T_J = 125^\circ\text{C}$
I_{GES}	Gate-to-Emitter Leakage Current	—	—	± 100	nA	$V_{GE} = \pm 20V$

Switching Characteristics @ $T_J = 25^\circ\text{C}$ (unless otherwise specified)

	Parameter	Min.	Typ.	Max.	Units	Conditions
Q_g	Total Gate Charge (turn-on)	—	—	150	nC	$I_C = 20A$
Q_{ge}	Gate - Emitter Charge (turn-on)	—	—	25		$V_{CC} = 300V$ See Fig. 8
Q_{gc}	Gate - Collector Charge (turn-on)	—	—	60		$V_{GE} = 15V$
$t_{d(on)}$	Turn-On Delay Time	—	—	50	ns	$T_J = 25^\circ\text{C}$
t_r	Rise Time	—	—	42		$I_C = 20A, V_{CC} = 480V$
$t_{d(off)}$	Turn-Off Delay Time	—	—	190		$V_{GE} = 15V, R_G = 9.1\Omega$
t_f	Fall Time	—	—	120		Energy losses include "tail"
E_{ts}	Total Switching Loss	—	—	1.0	mJ	See Fig. 10, 11, 13, 14
$t_{d(on)}$	Turn-On Delay Time	—	—	40	ns	$T_J = 125^\circ\text{C},$
t_r	Rise Time	—	—	40		$I_C = 20A, V_{CC} = 480V$
$t_{d(off)}$	Turn-Off Delay Time	—	—	300		$V_{GE} = 15V, R_G = 9.1\Omega$
t_r	Rise Time	—	—	250		Energy losses include "tail"
E_{ts}	Total Switching Loss	—	—	1.8	mJ	See Fig. 13, 14
L_C+L_E	Total Inductance	—	6.8	—	nH	Measured from Collector lead (6mm/0.25in. from package) to Emitter lead (6mm / 0.25in. from package)
C_{ies}	Input Capacitance	—	2215	—	pF	$V_{GE} = 0V$
C_{oes}	Output Capacitance	—	135	—		$V_{CC} = 30V$ See Fig. 7
C_{res}	Reverse Transfer Capacitance	—	25	—		$f = 1.0\text{MHz}$

Notes:

- ① Repetitive rating; $V_{GE} = 20V$, pulse width limited by max. junction temperature. (See fig. 13b)
- ② $V_{CC} = 80\%(V_{CES}), V_{GE} = 20V, L = 100\mu\text{H}, R_G = 9.1\Omega,$ (See fig. 13a)
- ③ Pulse width $\leq 80\mu\text{s}$; duty factor $\leq 0.1\%$.
- ④ Pulse width $5.0\mu\text{s}$, single shot.

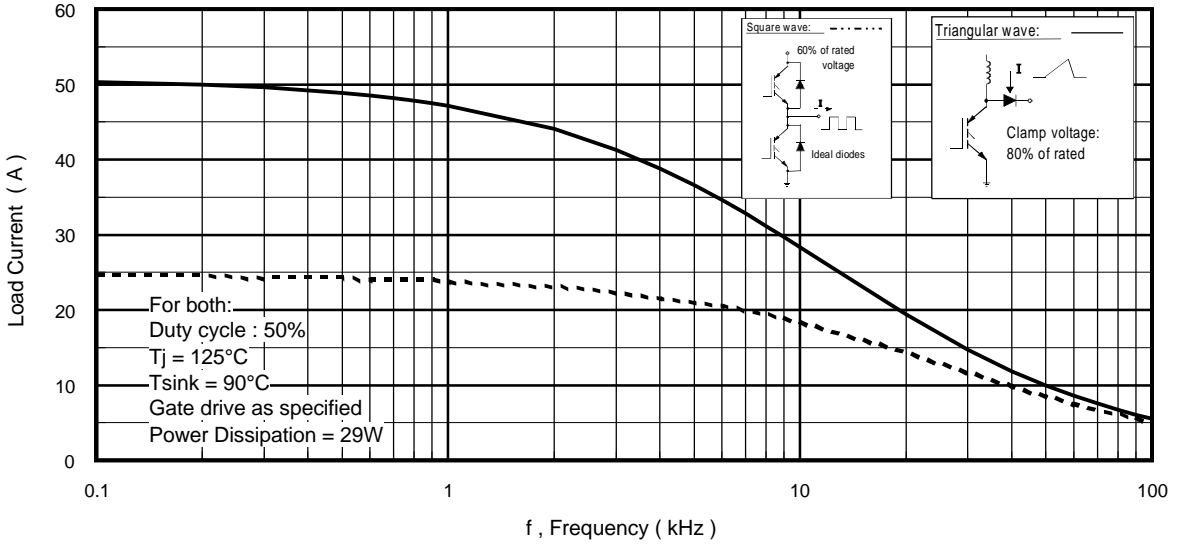

Fig. 1 - Typical Load Current vs. Frequency
(For square wave, $I = I_{RMS}$ of fundamental; for triangular wave, $I = I_{PK}$)

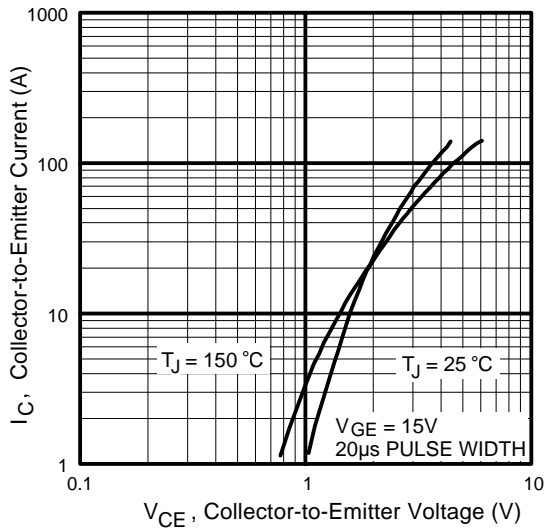

Fig. 2 - Typical Output Characteristics

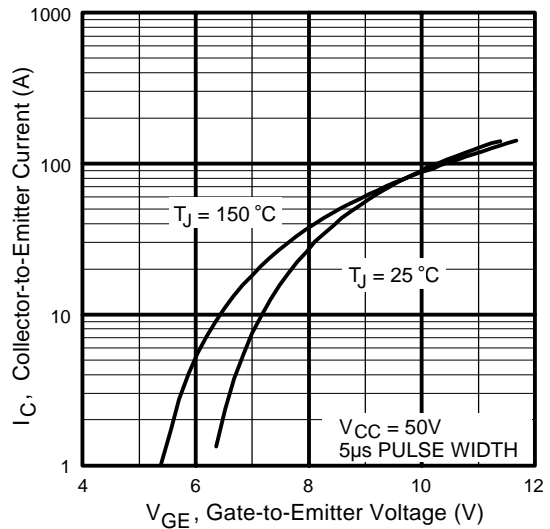

Fig. 3 - Typical Transfer Characteristics

IRG4MC40U

International
IR Rectifier

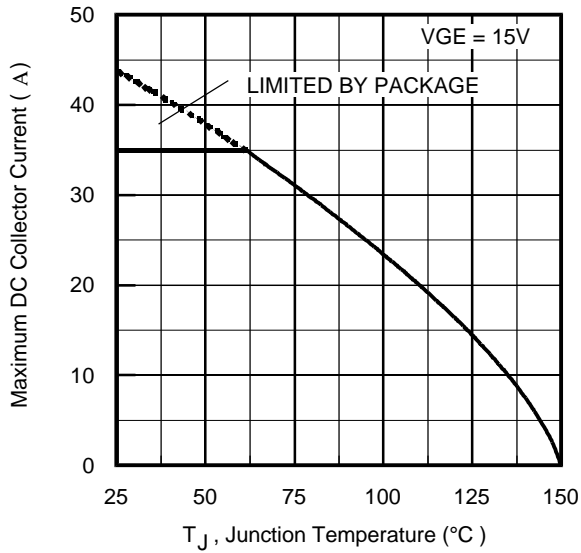

Fig. 4 - Maximum Collector Current vs. Case Temperature

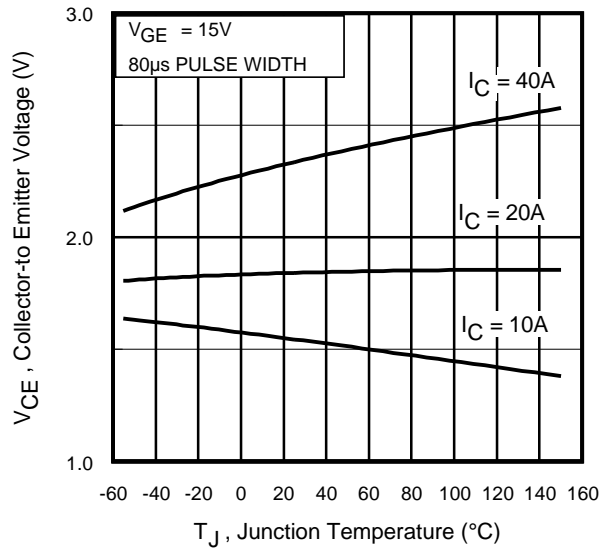

Fig. 5 - Collector-to-Emitter Voltage vs. Junction Temperature

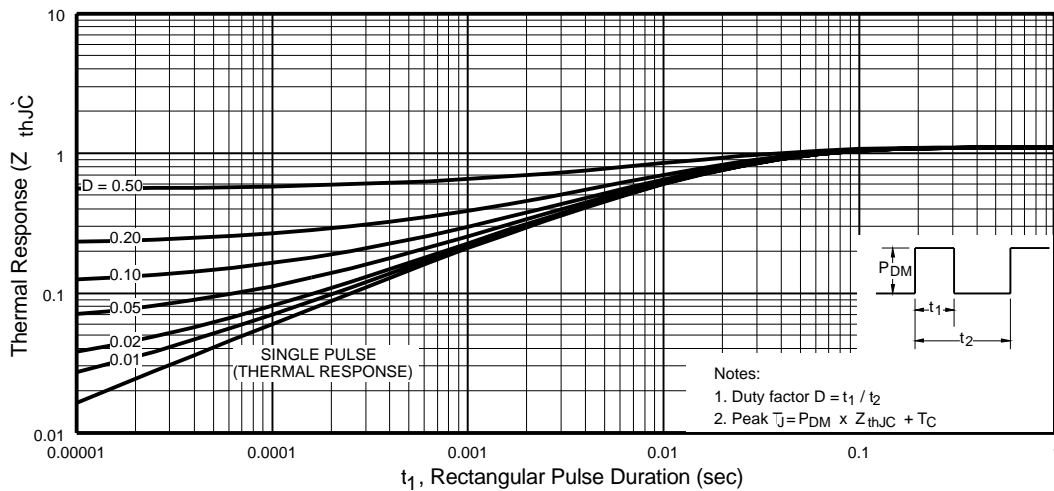

Fig. 6 - Maximum Effective Transient Thermal Impedance, Junction-to-Case

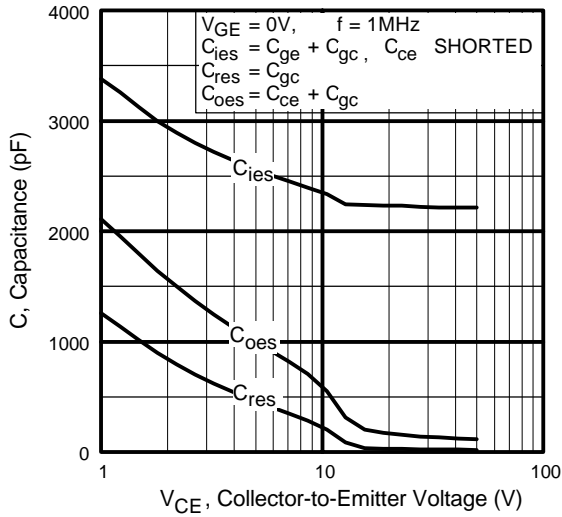

Fig. 7 - Typical Capacitance vs. Collector-to-Emitter Voltage

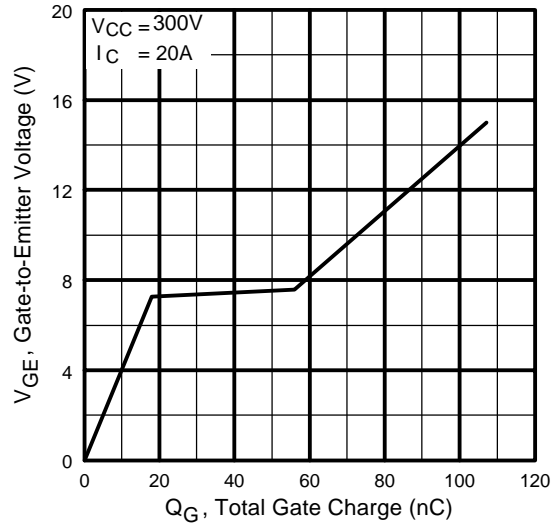

Fig. 8 - Typical Gate Charge vs. Gate-to-Emitter Voltage

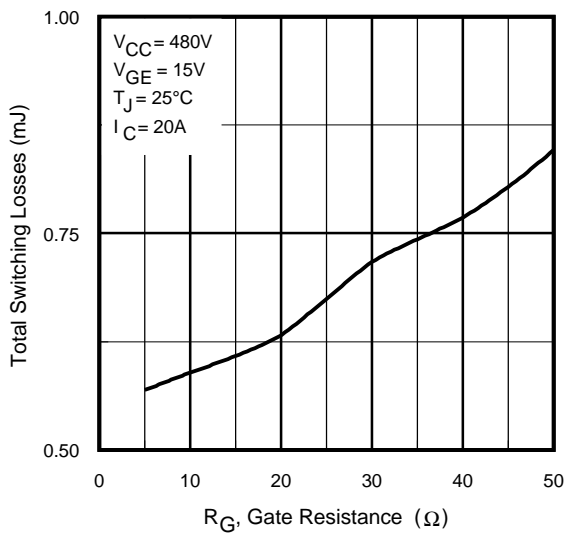

Fig. 9 - Typical Switching Losses vs. Gate Resistance

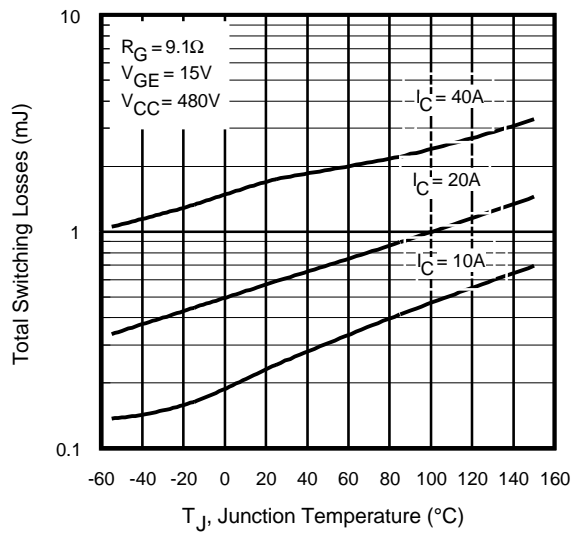

Fig. 10 - Typical Switching Losses vs. Junction Temperature

IRG4MC40U

International
IR Rectifier

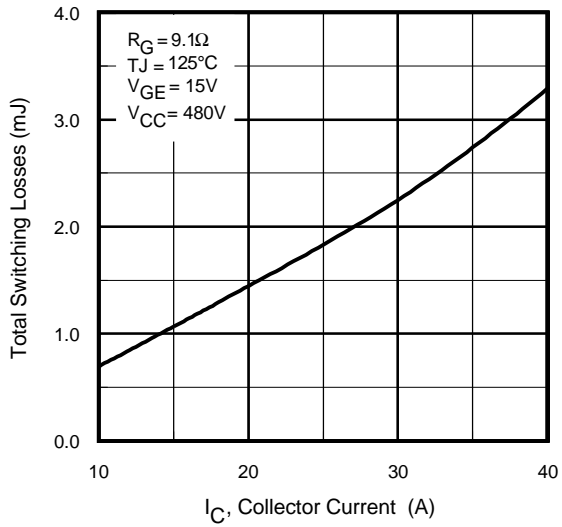

Fig. 11 - Typical Switching Losses vs. Collector-to-Emitter Current

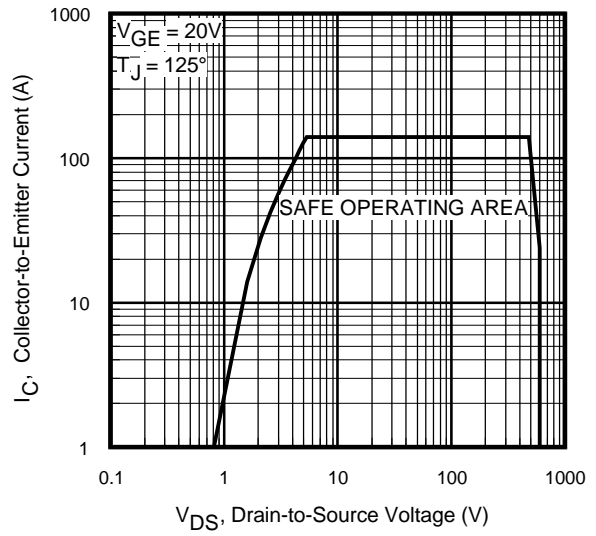

Fig. 12 - Turn-Off SOA

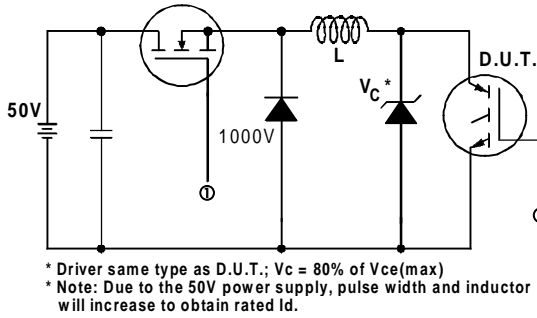

Fig. 13a - Clamped Inductive Load Test Circuit

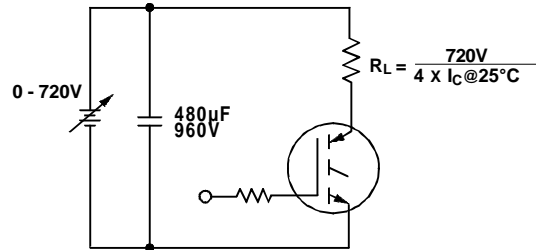

Fig. 13b - Pulsed Collector Current Test Circuit

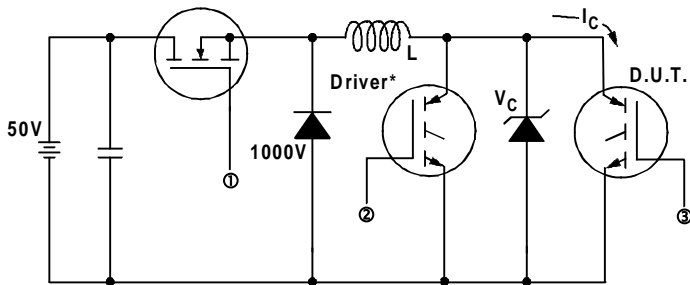

Fig. 14a - Switching Loss Test Circuit

* Driver same type as D.U.T., $V_C = 720V$

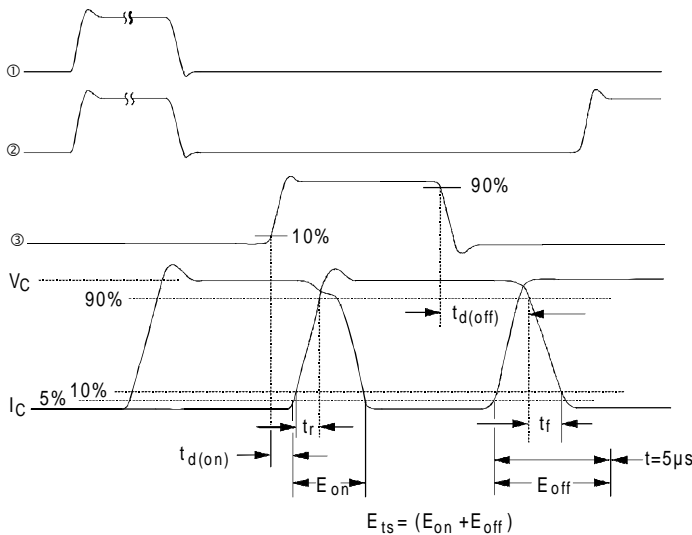
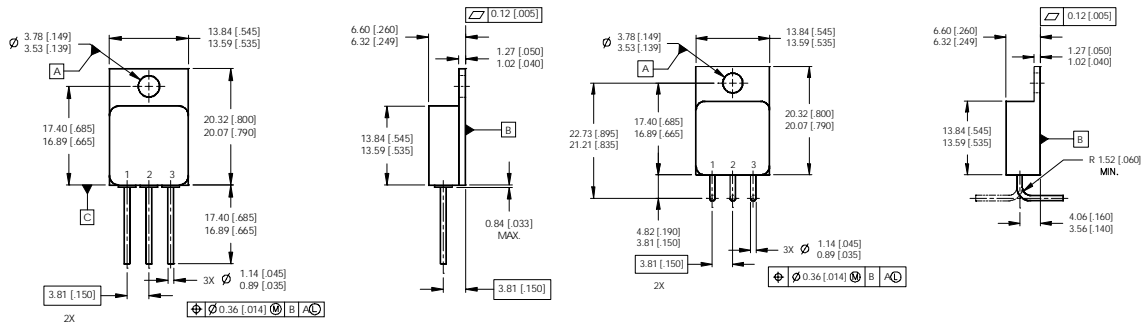

Fig. 14b - Switching Loss Waveforms

IRG4MC40U

International
IR Rectifier

Case Outline and Dimensions — TO-254AA



NOTES:

1. DIMENSIONING & TOLERANCING PER ASME Y14.5M-1994.
2. ALL DIMENSIONS ARE SHOWN IN MILLIMETERS [INCHES].
3. CONTROLLING DIMENSION: INCH.
4. CONFORMS TO JEDEC OUTLINE TO-254AA.

PIN ASSIGNMENTS

- 1=COLLECTOR
- 2=EMITTER
- 3=GATE

CAUTION

BERYLLIA WARNING PER MIL-PRF-19500

Packages containing beryllia shall not be ground, sandblasted, machined, or have other operations performed on them which will produce beryllia or beryllium dust. Furthermore, beryllium oxide packages shall not be placed in acids that will produce fumes containing beryllium.

International
IR Rectifier

IR WORLD HEADQUARTERS: 233 Kansas St., El Segundo, California 90245, USA Tel: (310) 252-7105
TAC Fax: (310) 252-7903

Visit us at www.irf.com for sales contact information.
Data and specifications subject to change without notice. 02/02