

International IR Rectifier

IRG4ZH70UD

INSULATED GATE BIPOLAR TRANSISTOR WITH
ULTRAFAST SOFT RECOVERY DIODE

Surface Mountable
UltraFast CoPack IGBT

Features

- UltraFast IGBT optimized for high switching frequencies
- IGBT co-packaged with HEXFRED™ ultrafast, ultra-soft recovery antiparallel diodes for use in bridge configurations
- Low Gate Charge
- Low profile low inductance SMD-10 Package
- Separated control & Power-connections for easy paralleling
- Inherently good coplanarity
- Easy solder inspection and cleaning

Benefits

- Highest power density and efficiency available
- HEXFRED Diodes optimized for performance with IGBTs. Minimized recovery characteristics
- IGBTs optimized for specific application conditions
- High input impedance requires low gate drive power
- Less noise and interference

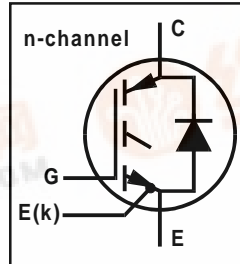

$$V_{CES} = 1200V$$

$$V_{CE(ON)typ} = 2.23V$$

$$@V_{GE} = 15V, I_C = 42A$$

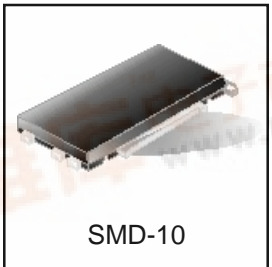

Absolute Maximum Ratings

	Parameter	Max.	Units
V_{CES}	Collector-to-Emitter Breakdown Voltage	1200	V
$I_C @ T_C = 25^\circ C$	Continuous Collector Current	78	A
$I_C @ T_C = 100^\circ C$	Continuous Collector Current	42	
I_{CM}	Pulsed Collector Current ①	312	
I_{LM}	Clamped Inductive Load Current ②	312	
$I_F @ T_C = 100^\circ C$	Diode Continuous Forward Current	42	
I_{FM}	Diode Maximum Forward Current	312	V
V_{GE}	Gate-to-Emitter Voltage	± 20	
$P_D @ T_C = 25^\circ C$	Maximum Power Dissipation	350	W
$P_D @ T_C = 100^\circ C$	Maximum Power Dissipation	140	
T_J T_{STG}	Operating Junction and Storage Temperature Range	-55 to + 150	$^\circ C$

Thermal Resistance

	Parameter	Min.	Typ.	Max.	Units
$R_{\theta JC}$	Junction-to-Case - IGBT	—	—	0.36	$^\circ C/W$
$R_{\theta JC}$	Junction-to-Case - Diode	—	—	0.69	
$R_{\theta CS}$	SMD-10 Case-to-Heatsink (typical), *	—	0.44	—	
	Weight	—	6.0(0.21)	—	g (oz)

* Assumes device soldered to 3.0 oz. Cu on 3.0mm IMS/Aluminum board, mounted to flat, greased heatsink.

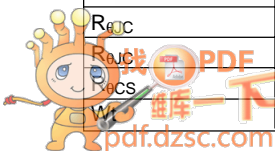

IRG4ZH70UD

International
IR Rectifier

Electrical Characteristics @ $T_J = 25^\circ\text{C}$ (unless otherwise specified)

	Parameter	Min.	Typ.	Max.	Units	Conditions
$V_{(BR)CES}$	Collector-to-Emitter Breakdown Voltage ③	1200	—	—	V	$V_{GE} = 0V, I_C = 250\mu A$
$\Delta V_{(BR)CES}/\Delta T_J$	Temperature Coeff. of Breakdown Voltage	—	1.20	—	V/°C	$V_{GE} = 0V, I_C = 1.0mA$
$V_{CE(on)}$	Collector-to-Emitter Saturation Voltage	—	2.23	3.5	V	$I_C = 42A, V_{GE} = 15V$
		—	2.58	—		$I_C = 78A$ see figures 2, 5
		—	2.15	—		$I_C = 42A, T_J = 150^\circ\text{C}$
$V_{GE(th)}$	Gate Threshold Voltage	3.0	—	6.0		$V_{CE} = V_{GE}, I_C = 250\mu A$
$\Delta V_{GE(th)}/\Delta T_J$	Temperature Coeff. of Threshold Voltage	—	-13	—	mV/°C	$V_{CE} = V_{GE}, I_C = 250\mu A$
g_{fe}	Forward Transconductance ④	30	46	—	S	$V_{CE} = 100V, I_C = 42A$
I_{CES}	Zero Gate Voltage Collector Current	—	—	250	μA	$V_{GE} = 0V, V_{CE} = 1200V$
		—	—	10	mA	$V_{GE} = 0V, V_{CE} = 1200V, T_J = 150^\circ\text{C}$
V_{FM}	Diode Forward Voltage Drop	—	2.45	3.7	V	$I_C = 42A$ see figure 13
		—	2.40	—		$I_C = 42A, T_J = 150^\circ\text{C}$
I_{GES}	Gate-to-Emitter Leakage Current	—	—	± 100	nA	$V_{GE} = \pm 20V$

Switching Characteristics @ $T_J = 25^\circ\text{C}$ (unless otherwise specified)

	Parameter	Min.	Typ.	Max.	Units	Conditions	
Q_g	Total Gate Charge (turn-on)	—	390	590	nC	$I_C = 42A$	
Q_{ge}	Gate - Emitter Charge (turn-on)	—	47	71		$V_{CC} = 400V$ see figure 8	
Q_{gc}	Gate - Collector Charge (turn-on)	—	120	180		$V_{GE} = 15V$	
$t_{d(on)}$	Turn-On Delay Time	—	100	—	ns	$T_J = 25^\circ\text{C}$	
t_r	Rise Time	—	28	—		$I_C = 42A, V_{CC} = 800V$	
$t_{d(off)}$	Turn-Off Delay Time	—	271	400		$V_{GE} = 15V, R_G = 5.0\Omega$	
t_f	Fall Time	—	189	280		Energy losses include "tail" and diode reverse recovery.	
E_{on}	Turn-On Switching Loss	—	3.0	—		mJ	see figures 9, 10, 18
E_{off}	Turn-Off Switching Loss	—	3.67	—			
E_{ts}	Total Switching Loss	—	6.67	9.8			
$t_{d(on)}$	Turn-On Delay Time	—	37	—	ns	$T_J = 150^\circ\text{C}$, see figures 11, 18	
t_r	Rise Time	—	124	—		$I_C = 42A, V_{CC} = 800V$	
$t_{d(off)}$	Turn-Off Delay Time	—	200	—		$V_{GE} = 15V, R_G = 5.0\Omega$	
t_f	Fall Time	—	435	—		Energy losses include "tail" and diode reverse recovery.	
E_{ts}	Total Switching Loss	—	12.36	—		mJ	
L_E	Internal Emitter Inductance	—	2.0	—	nH		
C_{ies}	Input Capacitance	—	7090	—	pF	$V_{GE} = 0V$	
C_{oes}	Output Capacitance	—	420	—		$V_{CC} = 30V$ see figure 7	
C_{res}	Reverse Transfer Capacitance	—	56	—		$f = 1.0MHz$	
t_{rr}	Diode Reverse Recovery Time	—	107	160	ns	$T_J = 25^\circ\text{C}$ see figure 14	
		—	160	240		$T_J = 125^\circ\text{C}$	
I_{rr}	Diode Peak Reverse Recovery Current	—	10	15	A	$T_J = 25^\circ\text{C}$ see figure 15	
		—	16	24		$T_J = 125^\circ\text{C}$	
Q_{rr}	Diode Reverse Recovery Charge	—	680	1020	nC	$T_J = 25^\circ\text{C}$ see figure 16	
		—	1400	2100		$T_J = 125^\circ\text{C}$	
$di_{(rec)}/dt$	Diode Peak Rate of Fall of Recovery During t_b	—	250	—	A/ μs	$T_J = 25^\circ\text{C}$ see figure 17	
		—	320	—		$T_J = 125^\circ\text{C}$	

Notes:

① Repetitive rating: $V_{GE} = 20V$; pulse width limited by maximum junction temperature (figure 20)

② $V_{CC} = 80\% (V_{CR})$, $V_{CE} = 20V$, $I = 10\mu H$, $R_G = 5.0\Omega$ (figure 19)

③ Pulse width $\leq 80\mu s$; duty factor $\leq 0.1\%$.

④ Pulse width 5.0 μs , single shot.

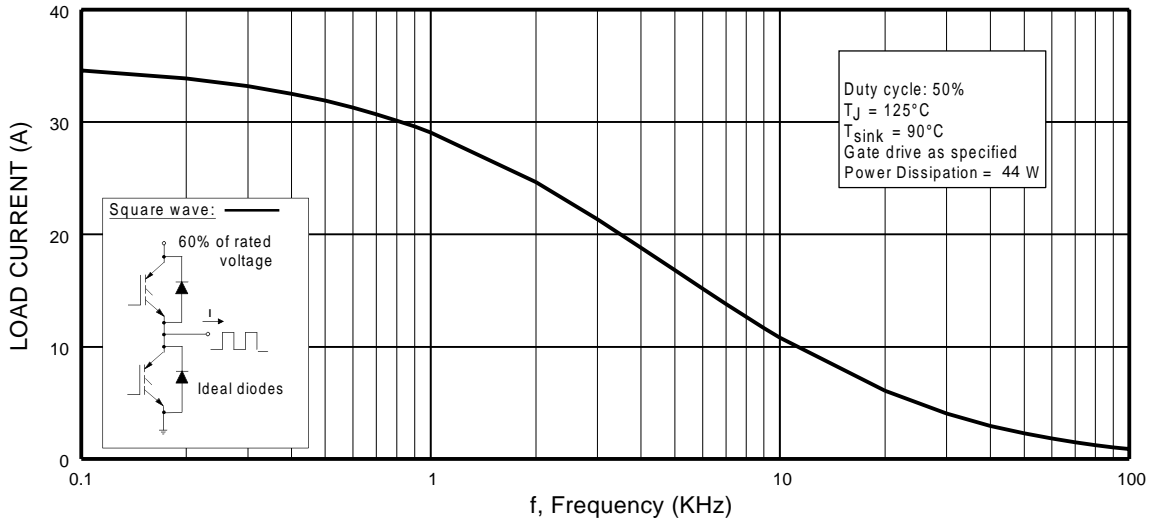

Fig. 1 - Typical Load Current vs. Frequency
 (Load Current = I_{RMS} of fundamental)

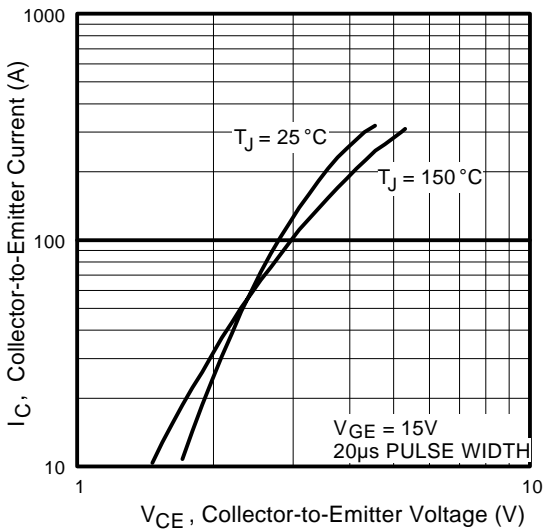

Fig. 2 - Typical Output Characteristics

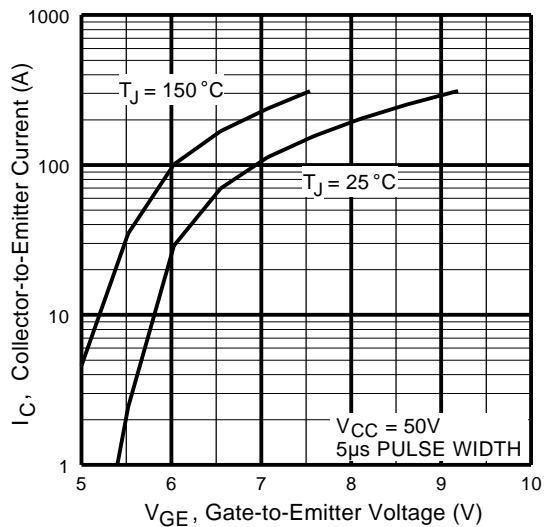

Fig. 3 - Typical Transfer Characteristics

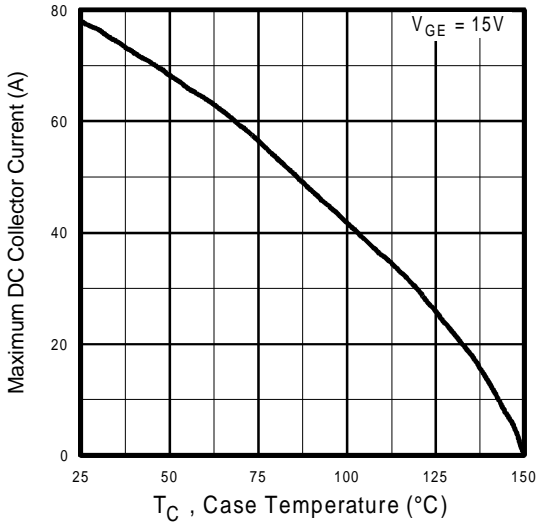

Fig. 4 - Maximum Collector Current vs. Case Temperature

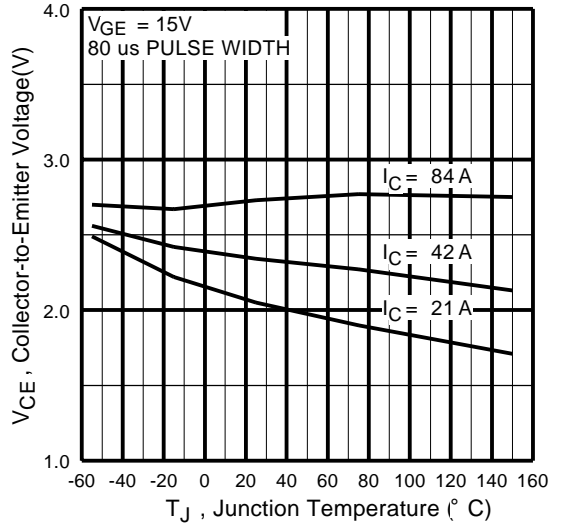

Fig. 5 - Typical Collector-to-Emitter Voltage vs. Junction Temperature

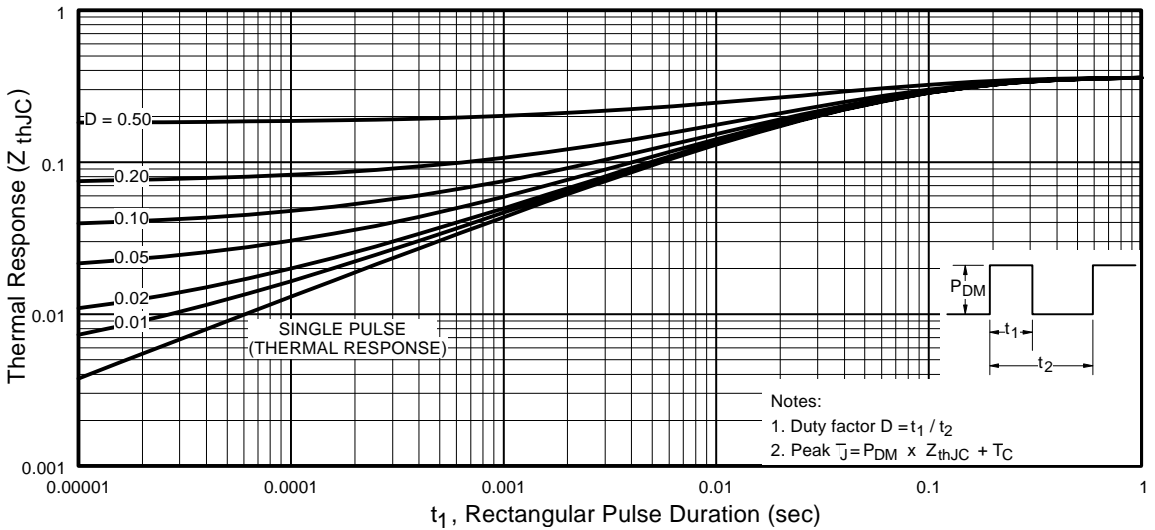

Fig. 6 - Maximum Effective Transient Thermal Impedance, Junction-to-Case

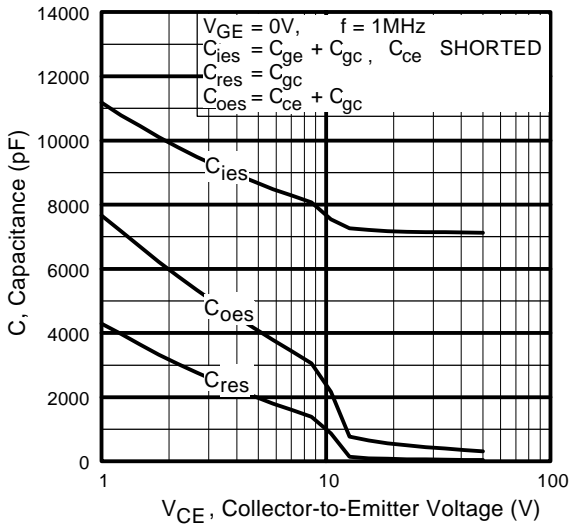

Fig. 7 - Typical Capacitance vs. Collector-to-Emitter Voltage

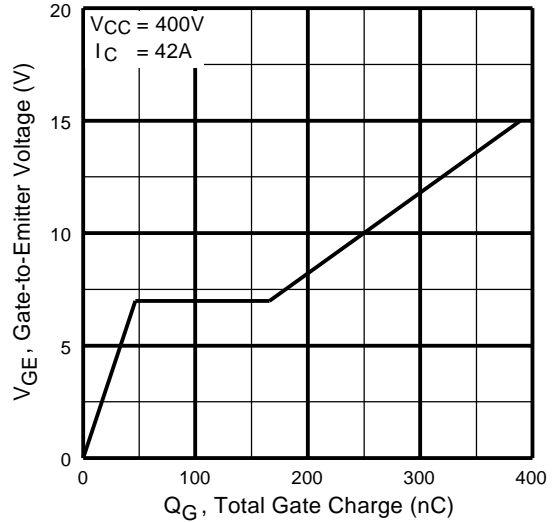

Fig. 8 - Typical Gate Charge vs. Gate-to-Emitter Voltage

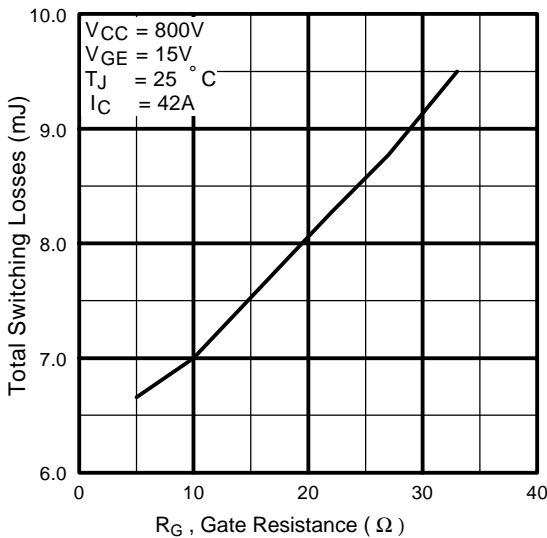

Fig. 9 - Typical Switching Losses vs. Gate Resistance

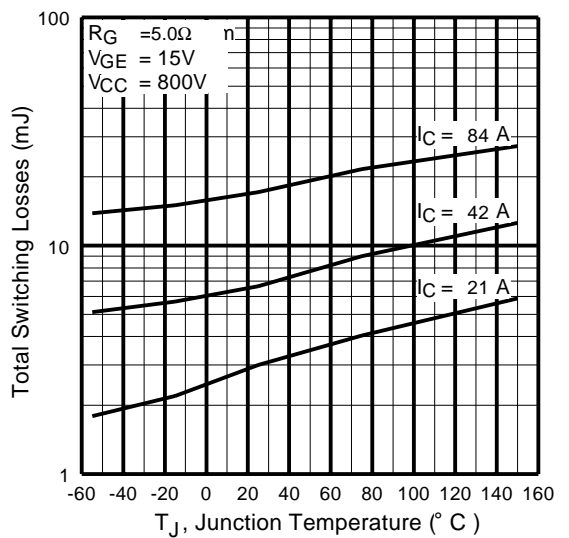

Fig. 10 - Typical Switching Losses vs. Junction Temperature

IRG4ZH70UD

International
IOR Rectifier

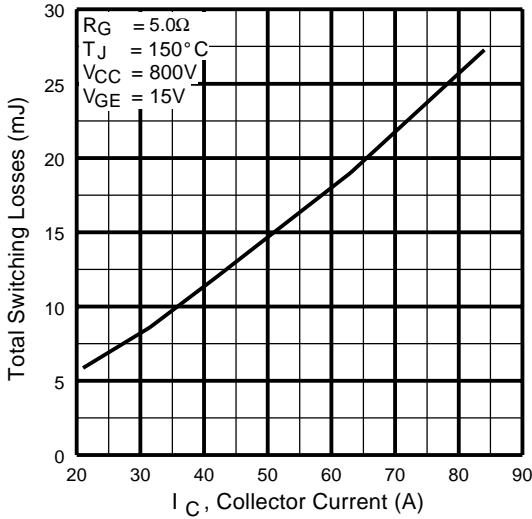

Fig. 11 - Typical Switching Losses vs. Collector-to-Emitter Current

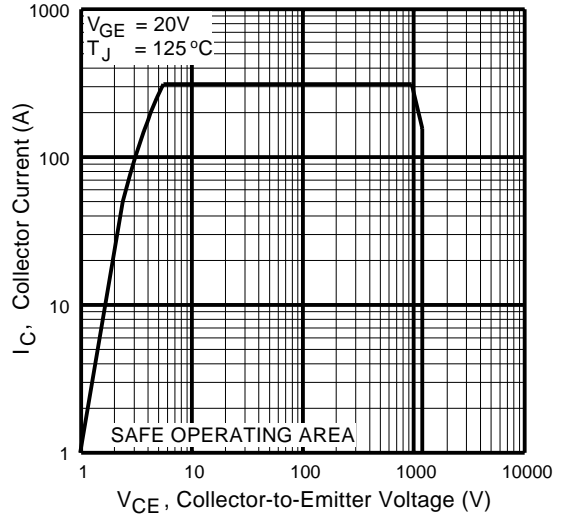

Fig. 12 - Turn-Off SOA

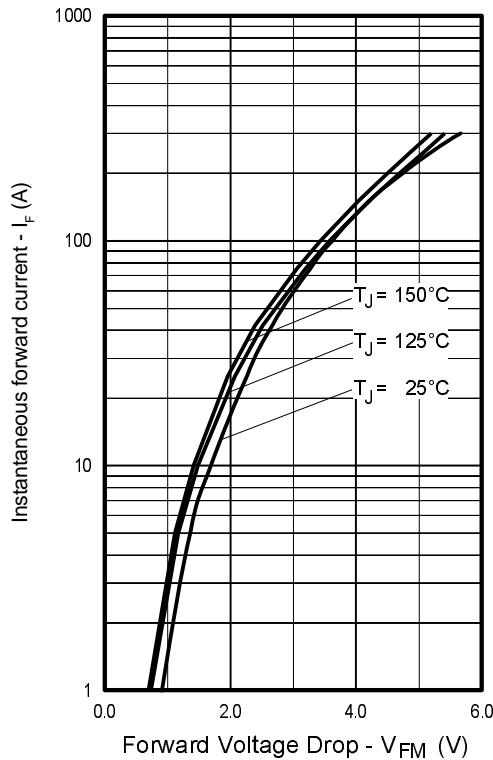

Fig. 13 - Typical Forward Voltage Drop vs. Instantaneous Forward Current

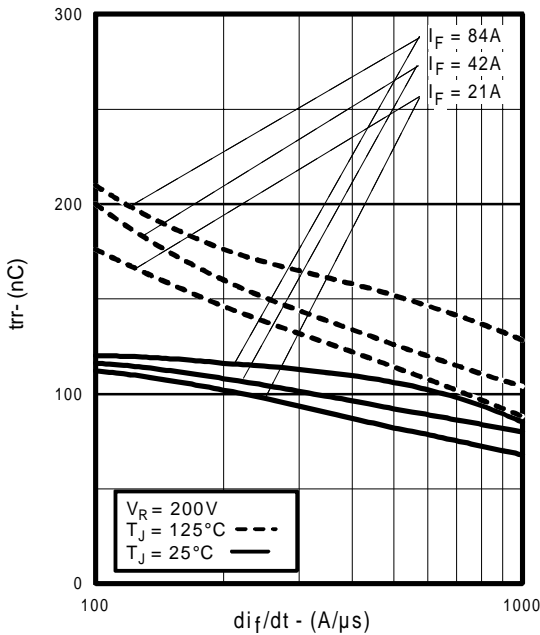

Fig. 14 - Typical Reverse Recovery vs. di_f/dt

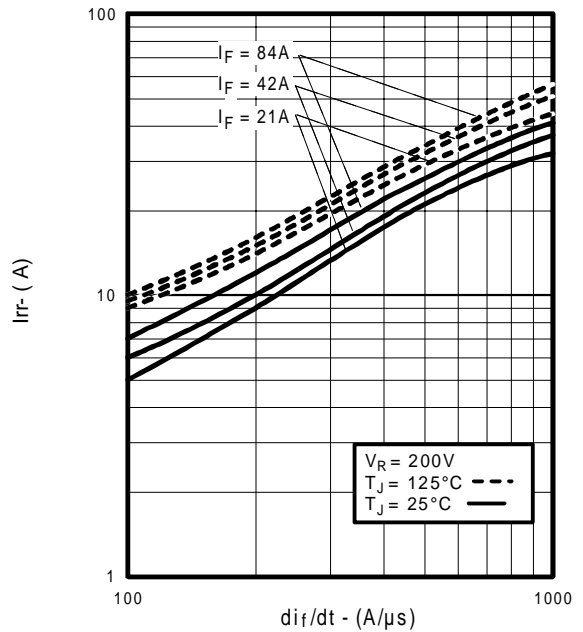

Fig. 15 - Typical Recovery Current vs. di_f/dt

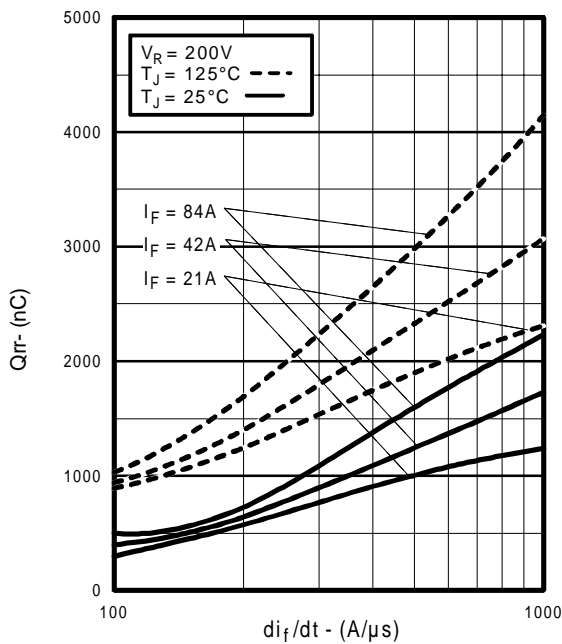

Fig. 16 - Typical Stored Charge vs. di_f/dt

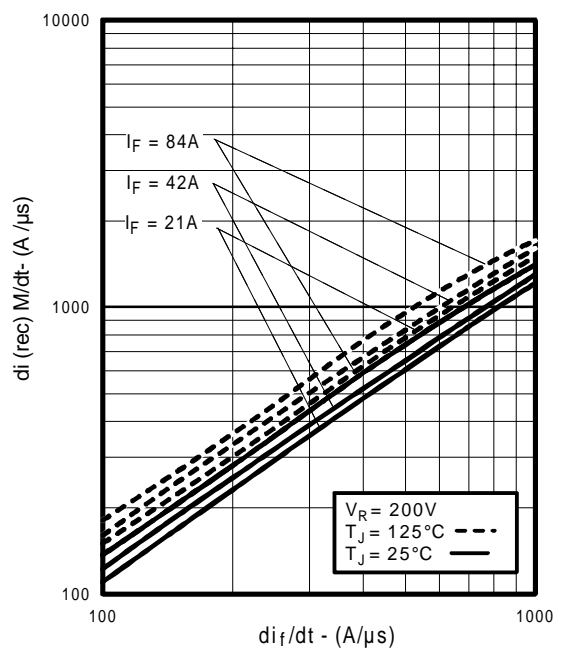

Fig. 17 - Typical $di_{(rec)}M/dt$ vs. di_f/dt

IRG4ZH70UD

International
IOR Rectifier

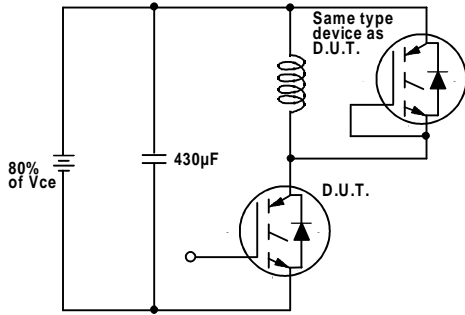

Fig. 18a - Test Circuit for Measurement of I_{LM} , E_{on} , $E_{off}(\text{diode})$, t_{rr} , Q_{rr} , I_{rr} , $t_{d(on)}$, t_r , $t_{d(off)}$, t_f

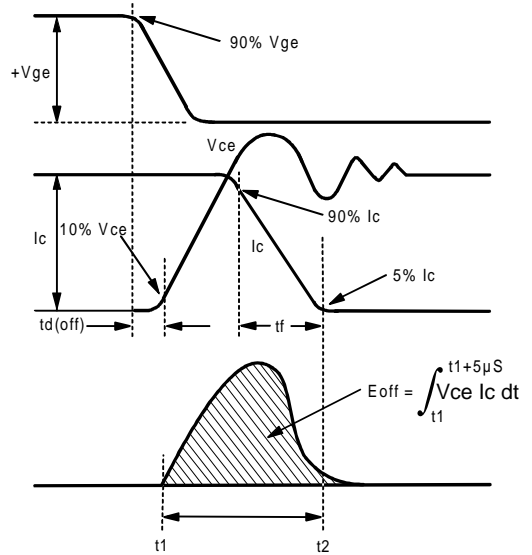

Fig. 18b - Test Waveforms for Circuit of Fig. 18a, Defining E_{off} , $t_{d(off)}$, t_f

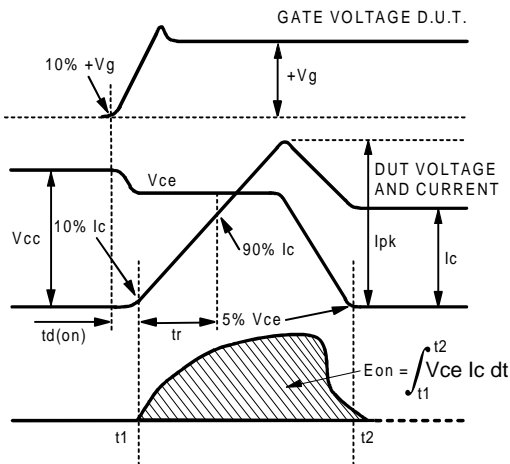

Fig. 18c - Test Waveforms for Circuit of Fig. 18a, Defining E_{on} , $t_{d(on)}$, t_r

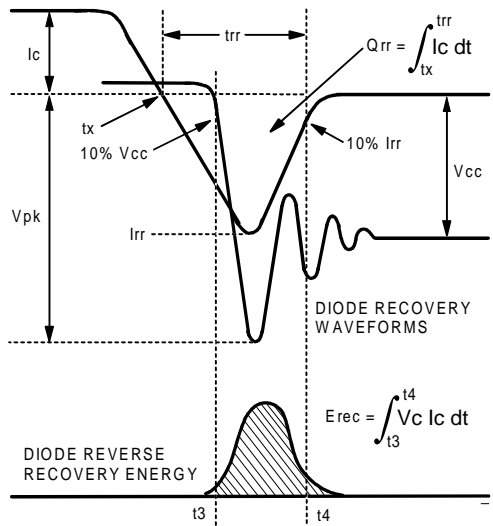

Fig. 18d - Test Waveforms for Circuit of Fig. 18a, Defining E_{rec} , t_{rr} , Q_{rr} , I_{rr}

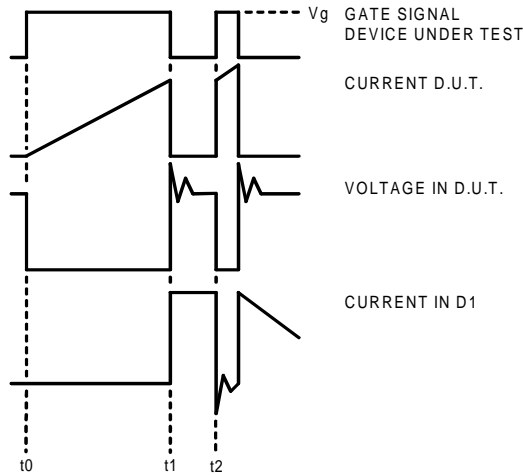

Figure 18e. Macro Waveforms for Figure 18a's Test Circuit

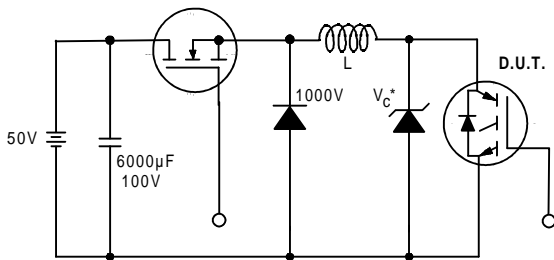

Figure 19. Clamped Inductive Load Test Circuit

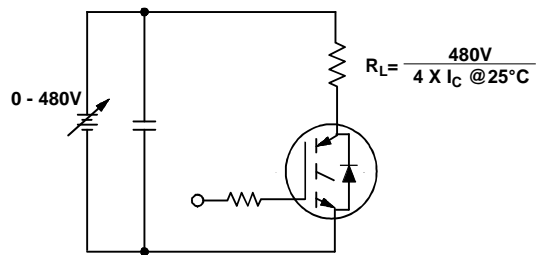

Figure 20. Pulsed Collector Current Test Circuit

IRG4ZH70UD

International
IOR Rectifier

Case Outline — SMD-10

Dimensions are shown in millimeters

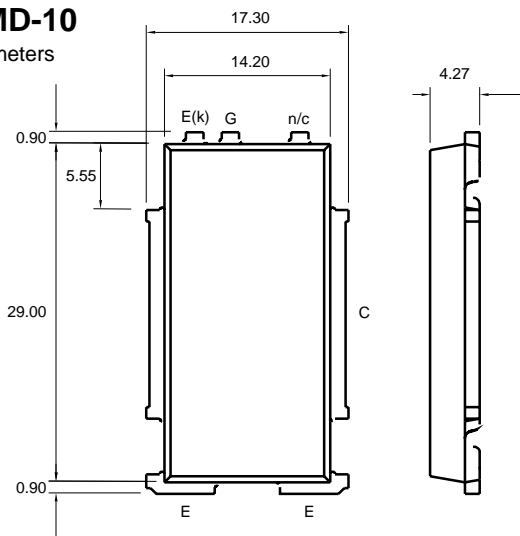

Recommended footprint

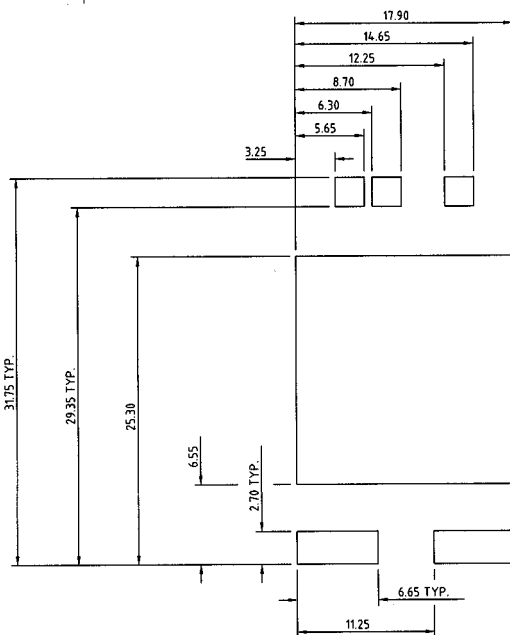

International
IOR Rectifier

WORLD HEADQUARTERS: 233 Kansas St., El Segundo, California 90245, Tel: (310) 322 3331
EUROPEAN HEADQUARTERS: Hurst Green, Oxted, Surrey RH8 9BB, UK Tel: ++ 44 1883 732020
IR CANADA: 7321 Victoria Park Ave., Suite 201, Markham, Ontario L3R 2Z8, Tel: (905) 475 1897

IR GERMANY: Saalburgstrasse 157, 61350 Bad Homburg Tel: ++ 49 6172 96590

IR ITALY: Via Liguria 49, 10071 Borgaro, Torino Tel: ++ 39 11 451 0111

IR FAR EAST: K&H Bldg., 2F, 30-4 Nishi-Ikebukuro 3-Chome, Toshima-Ku, Tokyo Japan 171 Tel: 81 3 3983 0086

IR SOUTHEAST ASIA: 315 Outram Road, #10-02 Tan Boon Liat Building, Singapore 0316 Tel: 65 221 8371

<http://www.irf.com/>

Data and specifications subject to change without notice.

3/98