

Ordering number:EN3927

NPN Epitaxial Planar Silicon Transistor



# 2SC4673

## UHF Low-Noise Amplifier, Wide-Band Amplifier Applications

### Features

- Low noise figure : NF=1.5dB typ (f=0.9GHz).
- High power gain :  $|S_{21e}|^2=8.0\text{dB typ (f=0.9GHz)}$ .
- High cutoff frequency :  $f_T=4.5\text{GHz typ}$ .

### Package Dimensions

unit:mm

2038A

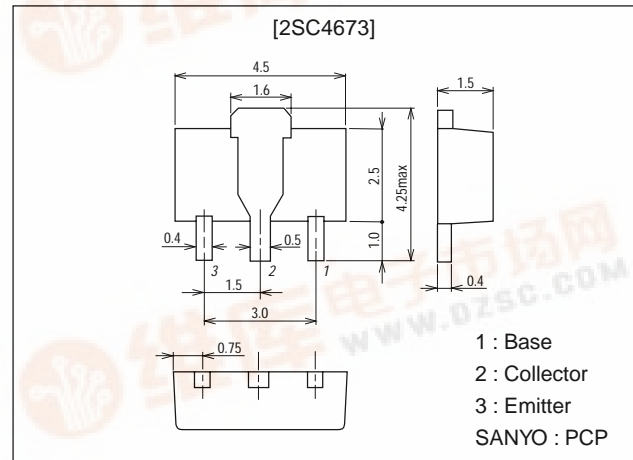

### Specifications

#### Absolute Maximum Ratings at Ta = 25°C

Parameter	Symbol	Conditions	Ratings	Unit
Collector-to-Base Voltage	V <sub>CBO</sub>		20	V
Collector-to-Emitter Voltage	V <sub>CEO</sub>		12	V
Emitter-to-Base Voltage	V <sub>EBO</sub>		3	V
Collector Current	I <sub>C</sub>		100	mA
Base Current	I <sub>B</sub>		30	mA
Collector Dissipation	P <sub>C</sub>		400	mW
		Mounted on ceramic board (250mm <sup>2</sup> ×0.8mm)	800	mW
Junction Temperature	T <sub>j</sub>		150	°C
Storage Temperature	T <sub>stg</sub>		-55 to +150	°C

#### Electrical Characteristics at Ta = 25°C

Parameter	Symbol	Conditions	Ratings			Unit
			min	typ	max	
Collector Cutoff Current	I <sub>CBO</sub>	V <sub>CB</sub> =12V, I <sub>E</sub> =0			1.0	μA
Emitter Cutoff Current	I <sub>EBO</sub>	V <sub>EB</sub> =2V, I <sub>C</sub> =0			10	μA
DC Current Gain	h <sub>FE</sub>	V <sub>CE</sub> =10V, I <sub>C</sub> =20mA	40*		200*	
Gain-Bandwidth Product	f <sub>T</sub>	V <sub>CE</sub> =10V, I <sub>C</sub> =20mA		4.5		GHz
Output Capacitance	C <sub>ob</sub>	V <sub>CB</sub> =10V, f=1MHz		1.1		pF
Reverse Transfer Capacitance	C <sub>re</sub>	V <sub>CB</sub> =10V, f=1MHz		0.75		pF

\* : The 2SC3778 is classified by 20mA h<sub>FE</sub> as follows :

40	C	80	60	D	120	100	E	200
----	---	----	----	---	-----	-----	---	-----

Marking : CD

h<sub>FE</sub> rank : C, D, E

- Any and all SANYO products described or contained herein do not have specifications that can handle applications that require extremely high levels of reliability, such as life-support systems, aircraft's control systems, or other applications whose failure can be reasonably expected to result in serious physical and/or material damage. Consult with your SANYO representative nearest you before using any SANYO products described or contained herein in such applications.
- SANYO assumes no responsibility for equipment failures that result from using products at values that exceed, even momentarily, rated values (such as maximum ratings, operating condition ranges, or other parameters) listed in products specifications of any and all SANYO products described or contained herein.



# 2SC4673

Parameter	Symbol	Conditions	Ratings			Unit
			min	typ	max	
Forward Transfer Gain	$ S_{21e} ^2$	$V_{CE}=10V, I_C=20mA, f=0.9GHz$		8.0		dB
Noise Figure	NF	$V_{CE}=10V, I_C=5mA, f=0.9GHz$		1.5	3.0	dB

## NF Test Circuit

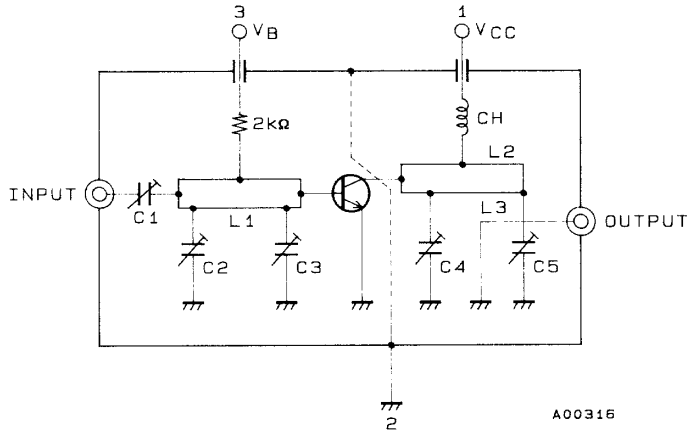

900MHz	
C1	up to 5pF
C2	up to 10pF
C3	up to 10pF
C4	up to 10pF
C5	up to 10pF
L1	W ≈ 1.5mm, l ≈ 25mm Strip line
L2	W ≈ 4mm, l ≈ 25mm Strip line
L3	0.5φ, l ≈ 4mm
CH	2t+bead core

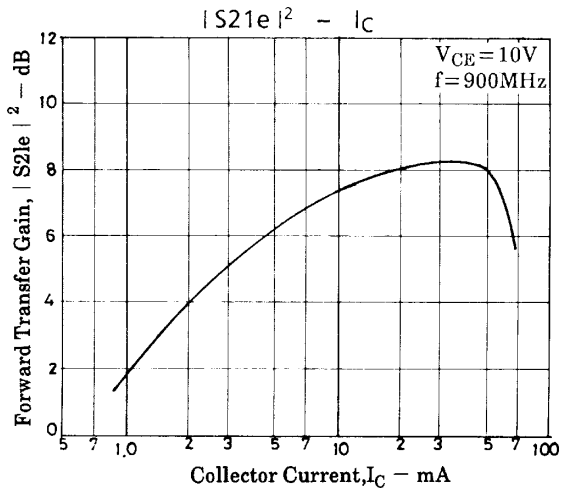
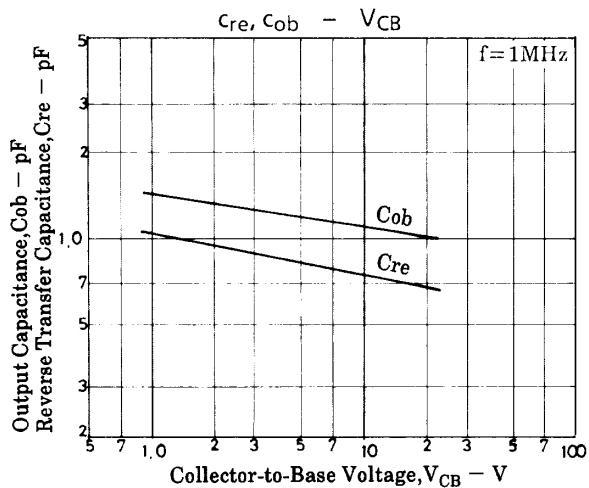
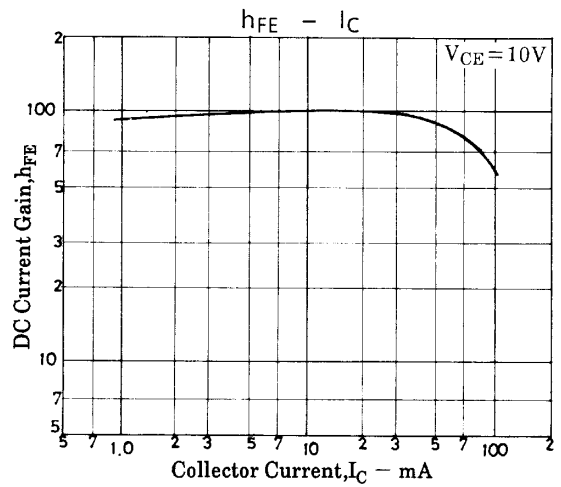
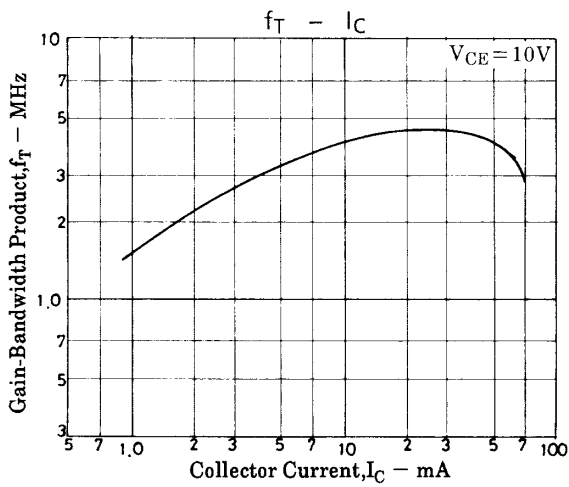

# 2SC4673

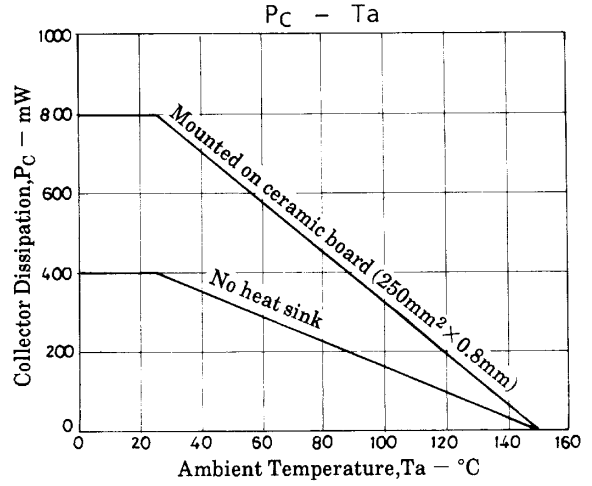
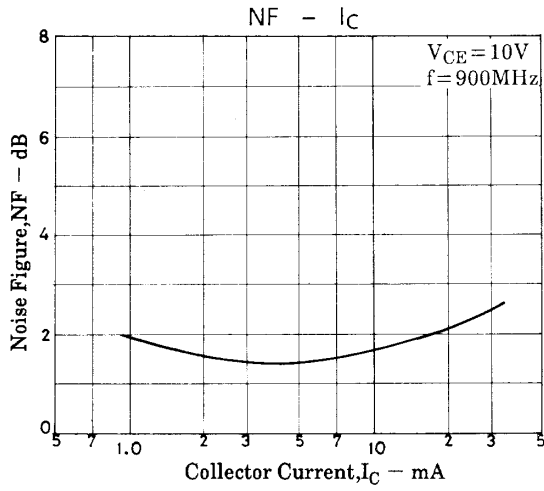

## S parameter

S11e:  $V_{CE} = 10V$   
 $f = 100MHz, 200$  to  $1200MHz$  (200MHz step)

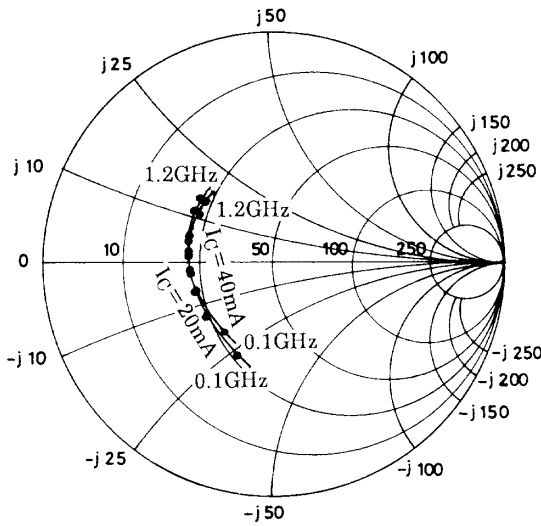

S12e:  $V_{CE} = 10V$   
 $f = 100MHz, 200$  to  $1200MHz$  (200MHz step)  
 $Z_o = 50\Omega$

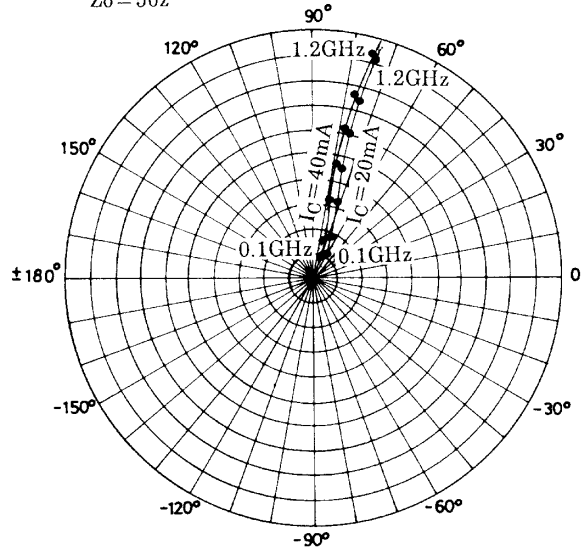

S21e:  $V_{CE} = 10V$   
 $f = 100MHz, 200$  to  $1200MHz$  (200MHz step)

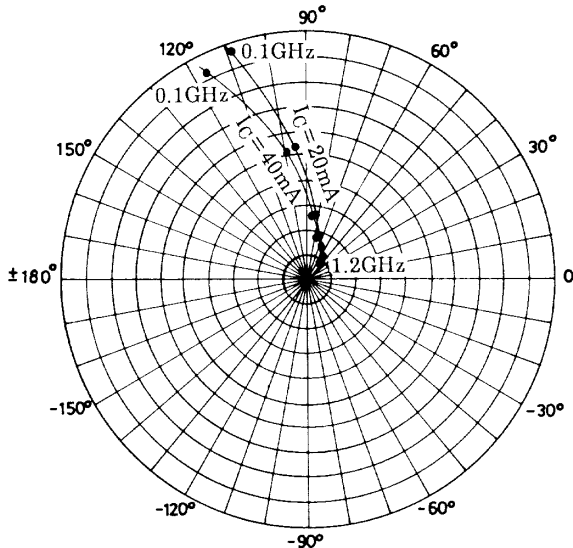

S22e:  $V_{CE} = 10V$   
 $f = 100MHz, 200$  to  $1200MHz$  (200MHz step)

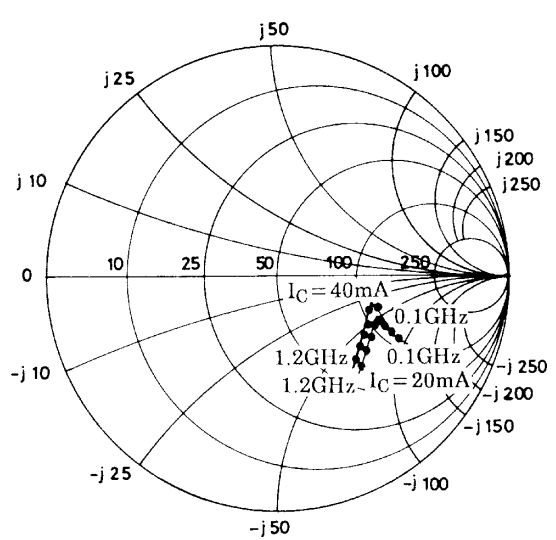

## 2SC4673

### S parameters (Common emitter)

$V_{CE}=10V, I_C=20mA, Z_0=50\Omega$

Freq (MHz)	S <sub>11</sub>		S <sub>21</sub>		S <sub>12</sub>		S <sub>22</sub>	
	MAG	ANG	MAG	ANG	MAG	ANG	MAG	ANG
100	0.414	-112.1	18.300	115.9	0.024	61.1	0.605	-26.4
200	0.372	-147.5	10.148	99.2	0.037	66.4	0.492	-23.5
400	0.364	-175.7	5.274	84.8	0.064	72.9	0.458	-23.0
600	0.369	170.1	3.619	75.6	0.093	75.3	0.460	-27.3
800	0.379	158.7	2.764	67.8	0.123	76.6	0.468	-32.6
900	0.366	153.6	2.504	66.4	0.139	75.4	0.475	-35.7
1000	0.388	148.5	2.279	60.8	0.152	75.1	0.478	-38.5
1200	0.399	140.5	1.914	54.2	0.184	74.0	0.487	-44.4

$V_{CE}=10V, I_C=40mA, Z_0=50\Omega$

Freq (MHz)	S <sub>11</sub>		S <sub>21</sub>		S <sub>12</sub>		S <sub>22</sub>	
	MAG	ANG	MAG	ANG	MAG	ANG	MAG	ANG
100	0.730	-133.7	19.714	109.3	0.021	66.4	0.535	-25.3
200	0.363	-161.5	10.534	95.3	0.035	72.5	0.452	-20.6
400	0.366	177.6	5.411	82.8	0.064	77.3	0.438	-21.1
600	0.371	166.7	3.690	74.3	0.094	77.9	0.444	-25.9
800	0.380	156.9	2.823	66.8	0.125	77.3	0.454	-31.7
900	0.389	153.1	2.562	63.5	0.142	76.8	0.462	-35.1
1000	0.391	148.3	2.329	59.9	0.155	76.1	0.465	-37.7
1200	0.404	141.3	1.982	53.6	0.186	74.7	0.474	-43.8

- Specifications of any and all SANYO products described or contained herein stipulate the performance, characteristics, and functions of the described products in the independent state, and are not guarantees of the performance, characteristics, and functions of the described products as mounted in the customer's products or equipment. To verify symptoms and states that cannot be evaluated in an independent device, the customer should always evaluate and test devices mounted in the customer's products or equipment.
- SANYO Electric Co., Ltd. strives to supply high-quality high-reliability products. However, any and all semiconductor products fail with some probability. It is possible that these probabilistic failures could give rise to accidents or events that could endanger human lives, that could give rise to smoke or fire, or that could cause damage to other property. When designing equipment, adopt safety measures so that these kinds of accidents or events cannot occur. Such measures include but are not limited to protective circuits and error prevention circuits for safe design, redundant design, and structural design.
- In the event that any or all SANYO products (including technical data, services) described or contained herein are controlled under any of applicable local export control laws and regulations, such products must not be exported without obtaining the export license from the authorities concerned in accordance with the above law.
- No part of this publication may be reproduced or transmitted in any form or by any means, electronic or mechanical, including photocopying and recording, or any information storage or retrieval system, or otherwise, without the prior written permission of SANYO Electric Co., Ltd.
- Any and all information described or contained herein are subject to change without notice due to product/technology improvement, etc. When designing equipment, refer to the "Delivery Specification" for the SANYO product that you intend to use.
- Information (including circuit diagrams and circuit parameters) herein is for example only ; it is not guaranteed for volume production. SANYO believes information herein is accurate and reliable, but no guarantees are made or implied regarding its use or any infringements of intellectual property rights or other rights of third parties.

This catalog provides information as of January, 1999. Specifications and information herein are subject to change without notice.