

Ordering number : ENN5340A

Monolithic Digital IC



LB1950V

Three-Phase Brushless Sensorless Motor Driver

Overview

The LB1950V is a 3-phase brushless sensorless motor driver IC that is particularly well-suited to driving camcorder drum motors.

Features

- Drives 3-phase full-wave brushless sensorless motors
- Soft switching drive
- Speed control using motor power-supply voltage control for reduced power
- Allows operation from a 3-V power supply.
- The residual output voltage can be set to one of four values.
- Supports bidirectional rotation.
- Standby function (only the FG and PG amplifiers operate)
- Brake circuit
- Thermal shutdown circuit
- FG and PG amplifiers

Package Dimensions

unit: mm

3191-SSOP30

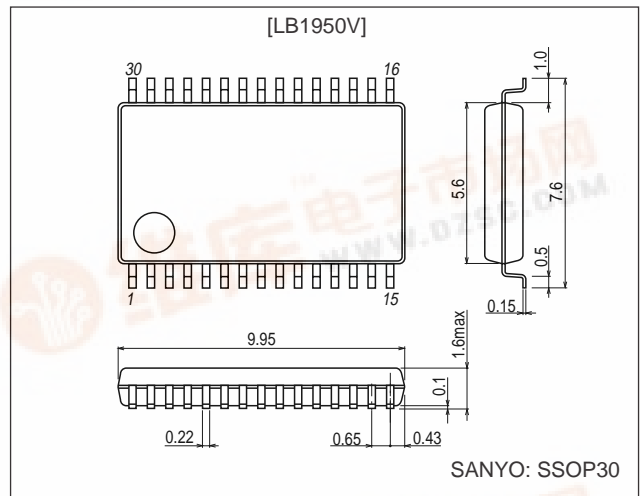

Specifications

Absolute Maximum Ratings at Ta = 25°C

Parameter	Symbol	Conditions	Ratings	Unit
Maximum supply voltage	V _{CC1} max		7	V
	V _{CC2} max		12	V
	V _S max		V _{CC2}	V
Output voltage	V _O max		V _S + 2	V
	V _{I1} max	Control system	-0.3 to V _{CC1} + 0.3	V
Input voltage	V _{I2} max	U, V, W, COM	V _S + 2	V
Output current	I _O max		1.0	A
Allowable power dissipation	P _d max		0.5	W
Operating temperature	T _{opr}		-20 to +75	°C
Storage temperature	T _{stg}		-55 to +150	°C

■ Any and all SANYO products described or contained herein do not have specifications that can handle applications that require extremely high levels of reliability, such as life-support systems, aircraft's control systems, or other applications whose failure can be reasonably expected to result in serious physical and/or material damage. Consult with your SANYO representative nearest you before using any SANYO products described or contained herein in such applications.

■ SANYO assumes no responsibility for equipment failures that result from using products at values that exceed, even momentarily, rated values (such as maximum ratings, operating condition ranges, or other parameters) listed in products specifications of any and all SANYO products described or contained herein.



LB1950V

Allowable Operating Ranges at Ta = 25°C

Parameter	Symbol	Conditions	Ratings	Unit
Supply voltage	V _{CC1}		2.7 to 6.0	V
	V _{CC2}		2.7 to 10.0	V
	V _S		0 to V _{CC2}	V

Electrical Characteristics at Ta = 25°C, V_{CC1} = 3 V, V_{CC2} = 4.75 V, V_S = 1 V

Parameter	Symbol	Conditions	min	typ	max	Unit
Current drain	I _{CC1}	I _O = 100 mA, RSAT1 = RSAT2 = GND		4.5	7	mA
	I _{CC2}	I _O = 100 mA, RSAT1 = RSAT2 = GND		1.2	2.5	mA
Output quiescent current	I _{CC10Q}	V _{STBY} = 0 V		1	1.5	mA
	I _{CC20Q}	V _{STBY} = 0 V			10	μA
	I _{S30Q}	V _{STBY} = 0 V			10	μA
Lower side output saturation voltage	V _{OU1}	I _O = 0.1 A, RSAT1 = RSAT2 = open			0.11	V
	V _{OU2}	I _O = 0.4 A, V _S = 3 V, RSAT1 = RSAT2 = open			0.33	V
Upper side output saturation voltage	V _{OD1}	I _O = 0.1 A, RSAT1 = RSAT2 = open			0.11	V
	V _{OD2}	I _O = 0.4 A, V _S = 3 V, RSAT1 = RSAT2 = open			0.33	V
COM pin common-mode input voltage range	V _{IC}		0.3		V _{CC2} - 0.9	V
Standby pin high-level voltage	V _{STBYH}		2		V _{CC1}	V
Standby pin low-level voltage	V _{STBYL}		-0.2		+0.7	V
Standby pin input current	I _{STBYI}	V _{STBY} = 3 V			50	μA
Standby pin leakage current	I _{STBYL}	V _{STBY} = 0 V	-10			μA
Brake pin high-level voltage	V _{BRH}		2		V _{CC1}	V
Brake pin low-level voltage	V _{BRL}		-0.2		+0.7	V
Brake pin input current	I _{BRI}	V _{BR} = 3 V			50	μA
Brake pin leakage current	I _{BRL}	V _{BR} = 0 V	-10			μA
FRC pin high-level voltage	V _{FRCH}		2		V _{CC1}	V
FRC pin low-level voltage	V _{FRCL}		-0.2		+0.7	V
FRC pin input current	I _{FRCI}	V _{FRC} = 3 V			50	μA
FRC pin leakage current	I _{FRCI}	V _{FRC} = 0 V	-10			μA
Slope pin source current ratio	R _{SOURCE}	ICSLP1SOURCE/ICSLP2SOURCE	-12		+12	%
Slope pin sink current ratio	R _{SINK}	ICSLP1SINK/ICSLP2SINK	-12		+12	%
CSLP1 source and sink current ratios	R _{CSLP1}	ICSLP1SOURCE/ICSLP1SINK	-35		+15	%
CSLP2 source and sink current ratios	R _{CSLP2}	ICSLP2SOURCE/ICSLP2SINK	-35		+15	%
Startup frequency	Freq	C _{OSC} = 0.1 μF, OSC frequency: *		11.5		Hz
Phase delay width	Dwidth	*		30		deg
Thermal shutdown temperature	T _{TSD}	*	150	180	210	°C
Thermal shutdown hysteresis	ΔT _{TSD}	*		15		°C
[FG Amplifier]						
Input offset voltage	V _{IO}	*		±1	±5	mV
Input bias current	I _B	*			250	nA
Common-mode input voltage range	V _{ICOM}	*	1		2	V
Output on voltage	V _{OL}	When I _O = 10 μA			0.4	V
Output off voltage	V _{OH}	When I _O = 10 μA	V _{CC1} - 0.5			V
Schmitt amplifier hysteresis	V _{SHIS}	*		50		mV
Output duty	Duty	When the input signal level = 20 mVp-p and the input frequency = 720 Hz.	30		70	%
Reference voltage	V _{REF}		1.15	1.30	1.45	V
[PG Amplifier]						
Input offset voltage	V _{IO}	*		±1	±5	mV
Input bias current	I _B	*			500	nA
Common-mode input voltage range	V _{ICOM}	*	1		2	V
Output on voltage	V _{OL}	When I _O = 10 μA			0.4	V
Output off voltage	V _{OH}	When I _O = 10 μA	V _{CC1} - 0.5			V
Schmitt amplifier hysteresis	V _{SHIS}	*		20		mV

Note: * Items marked with an asterisk are design target values and are not tested.

LB1950V

Pin Assignment

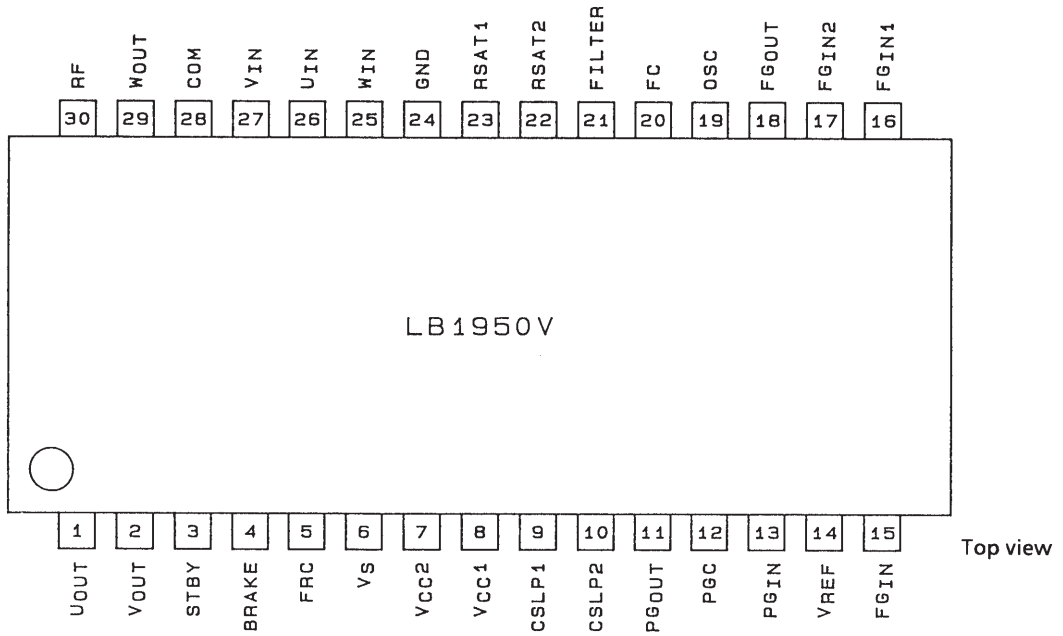

A05063

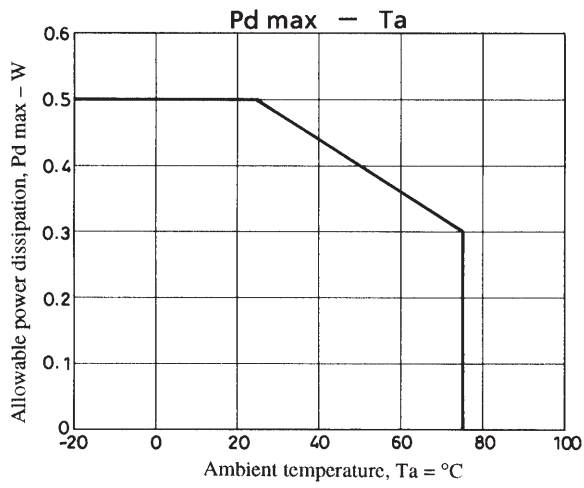

LB1950V

Pin Functions

Pin No.	Symbol	Pin voltage	Equivalent circuit	Function
3	STBY	$V_{CC1} \text{ max} - 0.2 \text{ V min}$	<p style="text-align: right;">A05065</p>	<ul style="list-style-type: none"> The LB1950V is set to a mode in which only the FG and PG amplifiers operate when this pin is open or set to a voltage 0.7 V or lower. This pin must be set to a voltage 2.0 V or higher in the motor drive state.
4	BR	$V_{CC1} \text{ max} - 0.2 \text{ V min}$	<p style="text-align: right;">A05066</p>	<ul style="list-style-type: none"> Braking is applied to the motor if a voltage 2.0 V or higher is applied to this pin. This pin must be open or set to a voltage 0.7 V or lower to set the LB1950V to the motor drive state.
5	FRC	$V_{CC1} \text{ max} - 0.2 \text{ V min}$	<p style="text-align: right;">A05067</p>	<ul style="list-style-type: none"> Motor forward/reverse switching input Low level: forward (-0.2 to 0.7 V or open) High level: reverse (2 V to V_{CC1})
6	V_S	0 V to V_{CC2}		<ul style="list-style-type: none"> Power supply that provides the motor voltage and determines the output amplitude. This voltage must be lower than V_{CC2}.
7	V_{CC2}	2.7 to 10 V		Power supply that provides the source side pre-drive voltage and the coil waveform detection comparator voltage.
8	V_{CC1}	2.7 to 6 V		Power supply that provides the voltages other than the motor voltage, the source side predrive voltage, and the coil waveform detection comparator voltage.
9 10	CSLP1 CSLP2		<p style="text-align: right;">A05068</p>	Connection for the triangular wave generator. The coil output waveform is made to operate in a soft switching manner by this triangular wave.

Continued on next page.

LB1950V

Continued from preceding page.

Pin No.	Symbol	Pin voltage	Equivalent circuit	Function
11	PG _{OUT}		<p style="text-align: right;">A05069</p>	PG amplifier output
12	PGC		<p style="text-align: right;">A05070</p>	Connection for the PG amplifier peak-hold capacitor
13	PG _{IN}	2.0 V max 1.0 V min (when V _{CC1} = 3 V)	<p style="text-align: right;">A05071</p>	<ul style="list-style-type: none"> PG amplifier input Connect the PG coil between this pin and V_{REF}.
14	V _{REF}		<p style="text-align: right;">A05072</p>	<ul style="list-style-type: none"> Internal 1.3-V reference voltage This voltage is used as the FG and PG amplifier reference voltage.
15	FG _{IN}		<p style="text-align: right;">A05073</p>	FG amplifier input Connect the FG coil between this pin and V _{REF} .
16	FG _{IN1}	2.0 V max 1.0 V min (when V _{CC1} = 3 V)	<p style="text-align: right;">A05073</p>	Connection for an FG amplifier input signal noise filter capacitor
17	FG _{IN2}		<p style="text-align: right;">A05073</p>	Connection for an FG amplifier input signal noise filter capacitor

Continued on next page.

LB1950V

Continued from preceding page.

Pin No.	Symbol	Pin voltage	Equivalent circuit	Function
18	FG _{OUT}		<p style="text-align: right;">A05074</p>	FG amplifier output
19	OSC		<p style="text-align: right;">A05075</p>	Connection for the triangular wave oscillator capacitor that is used to forcibly generate the motor startup waveform at startup.
20	FC		<p style="text-align: right;">A05076</p>	<ul style="list-style-type: none"> • Frequency characteristics determination • Current control system closed loop oscillation can be stopped by connecting a capacitor between this pin and ground.
21	FILTER		<p style="text-align: right;">A05077</p>	Connecting a capacitor between this pin and ground causes the coil output saturation prevention function to operate. In this state, the motor voltage is controlled by controlling the VS pin. Also, the torque ripple correction can be adjusted by changing the value of the external capacitor.
22 23	RSAT1 RSAT2		<p style="text-align: right;">A05078</p>	The residual output voltage setting can be increased by connecting one, the other, or both of these pins to ground.
24	GND			Ground for all systems other than the output system.

Continued on next page.

LB1950V

Continued from preceding page.

Pin No.	Symbol	Pin voltage	Equivalent circuit	Function
25 26 27	W_{IN} U_{IN} V_{IN}			Coil waveform detector comparator input
28	COM			<ul style="list-style-type: none"> • Motor coil center tap input • The LB1950V detects the coil voltage waveform taking this voltage as the reference.
29 1 2	W_{OUT} U_{OUT} V_{OUT}			<ul style="list-style-type: none"> • W-phase coil output • U-phase coil output • V-phase coil output
30	RF			<ul style="list-style-type: none"> • Output transistor ground • The LB1950V implements fixed-current drive by detecting the voltage on this pin.

A05080

LB1950V

Block Diagram

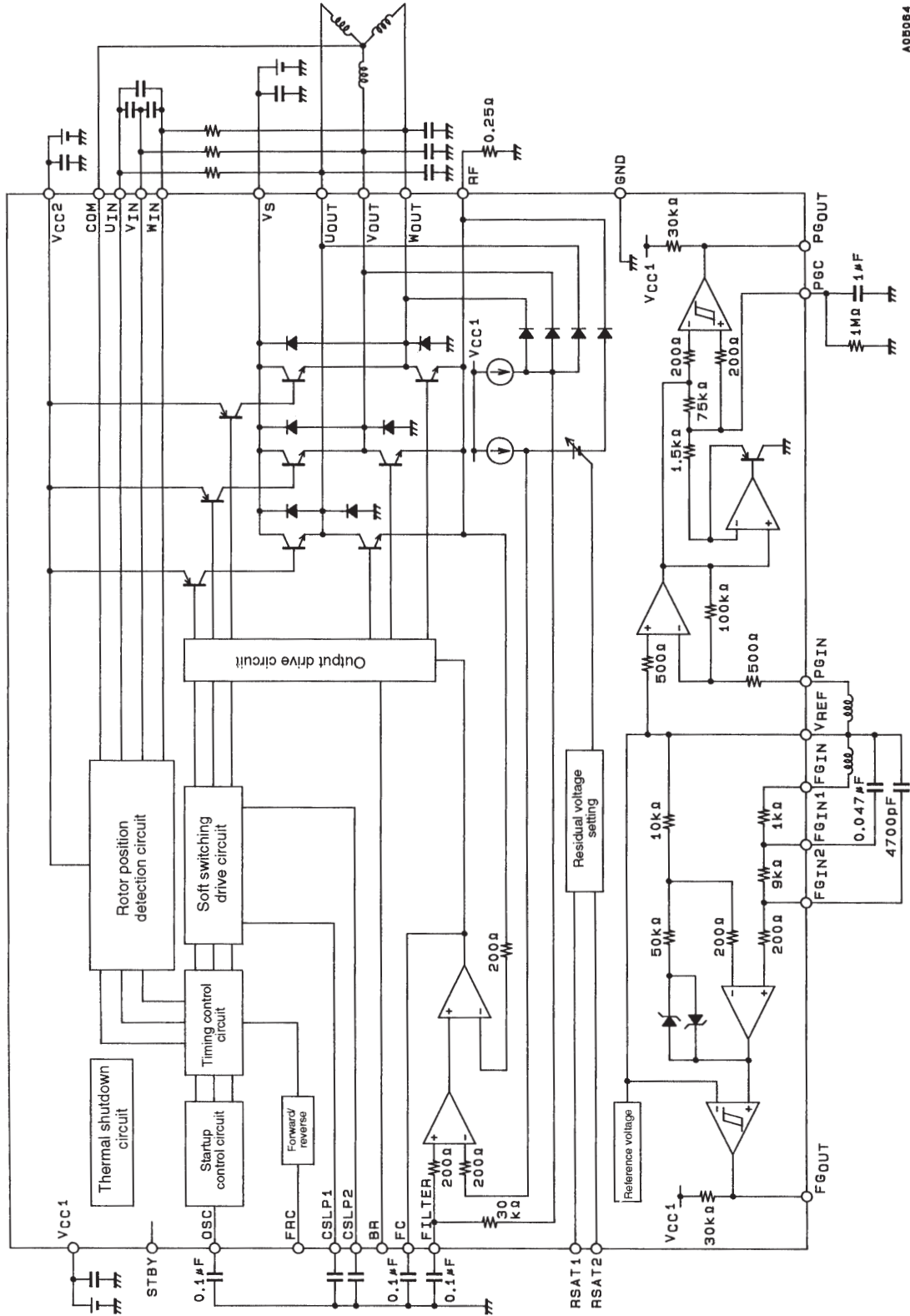

A05084

Note: (The values of external components vary depending on the motor used.)
 The FG_{IN} and PG_{IN} pins must be connected to the V_{REF} pin if the FG and PG amplifiers are not used.

LB1950V

Control System Operation

The LB1950V is a current-linear drive motor driver. It implements motor power-supply voltage based speed control by continually preventing coil output saturation and maintaining the output saturation voltage at the value set by the circuit.

1. The LB1950V detects the sum of the coil output voltage lower side envelope and the diode threshold voltage.
2. The low-pass filter formed by the internal 30-k Ω resistance and the capacitor connected between the FILTER and GND pins cuts the high-frequency components of the envelope waveform. (The cutoff frequency is $1/2\pi CR$.)
3. The FILTER pin voltage is input to the control amplifier + pin. The reference voltage is input to the control amplifier – pin, and the control amplifier operates to force the FILTER pin voltage to the same potential as the reference voltage. The coil output operates in the unsaturated region if this reference voltage is higher than the output transistor saturation voltage.
4. Also, since the second control amplifier stage controls the RF voltage to a fixed level, the output current (i.e., the RF current) becomes a fixed current drive.

Supplement: The low-frequency components that are not filtered out by the RC filter on the FILTER pin function to correct motor torque ripple.

Control System Signals

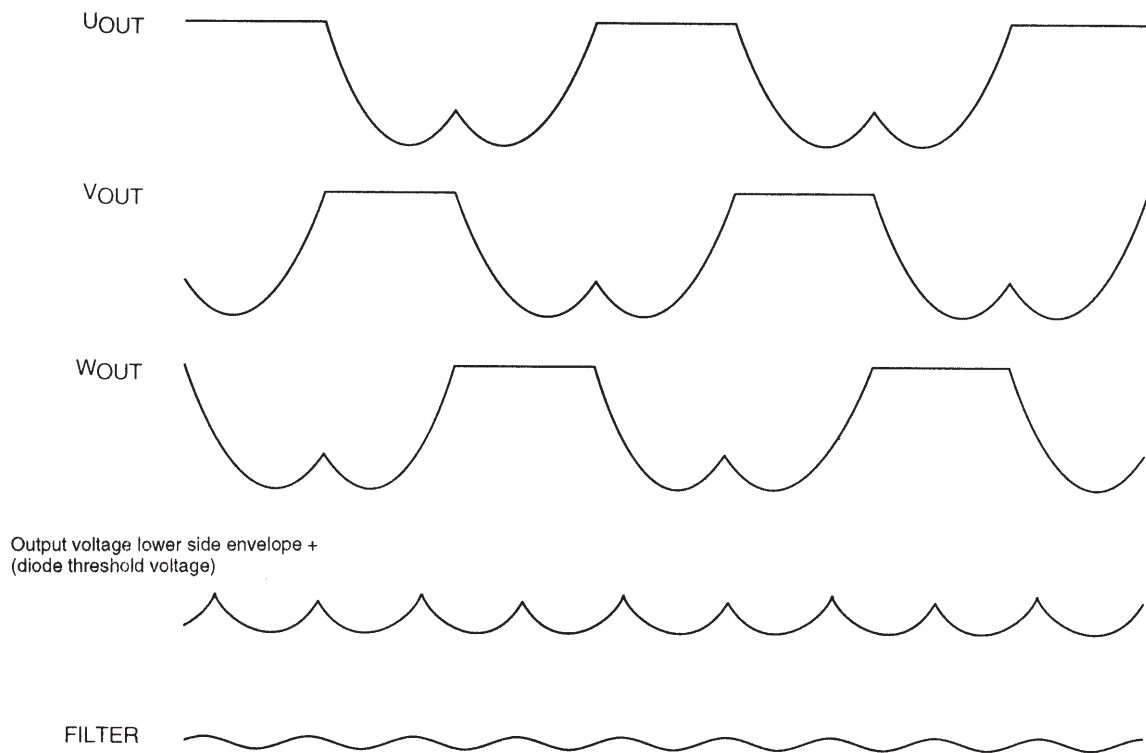

- Specifications of any and all SANYO products described or contained herein stipulate the performance, characteristics, and functions of the described products in the independent state, and are not guarantees of the performance, characteristics, and functions of the described products as mounted in the customer's products or equipment. To verify symptoms and states that cannot be evaluated in an independent device, the customer should always evaluate and test devices mounted in the customer's products or equipment.
- SANYO Electric Co., Ltd. strives to supply high-quality high-reliability products. However, any and all semiconductor products fail with some probability. It is possible that these probabilistic failures could give rise to accidents or events that could endanger human lives, that could give rise to smoke or fire, or that could cause damage to other property. When designing equipment, adopt safety measures so that these kinds of accidents or events cannot occur. Such measures include but are not limited to protective circuits and error prevention circuits for safe design, redundant design, and structural design.
- In the event that any or all SANYO products (including technical data, services) described or contained herein are controlled under any of applicable local export control laws and regulations, such products must not be exported without obtaining the export license from the authorities concerned in accordance with the above law.
- No part of this publication may be reproduced or transmitted in any form or by any means, electronic or mechanical, including photocopying and recording, or any information storage or retrieval system, or otherwise, without the prior written permission of SANYO Electric Co., Ltd.
- Any and all information described or contained herein are subject to change without notice due to product/technology improvement, etc. When designing equipment, refer to the "Delivery Specification" for the SANYO product that you intend to use.
- Information (including circuit diagrams and circuit parameters) herein is for example only; it is not guaranteed for volume production. SANYO believes information herein is accurate and reliable, but no guarantees are made or implied regarding its use or any infringements of intellectual property rights or other rights of third parties.