

Ordering number : EN6108

CMOS IC

SANYO

LC75397E

Single Chip Electronic Volume and Tone Control System



Overview

The LC75397 is an electronic volume control system providing control over volume, balance, 4-band equalizer, bass, and input switching based on serial inputs.

Functions

- **Volume control:**
The chip provides 81 levels of volume attenuation: in 1-dB step between 0 dB and -79 dB and -∞. This circuit can control a total of 5 independent channels.
- **Equalizer:**
The chip provides control in 2-dB steps over the range between +10 dB and -10 dB. Three of the four bands have peaking equalization; the remaining one, shelving equalization.
- **Selector:**
The left and right channels each offer a choice of six inputs. The L6 and R6 inputs can be turned on and off independently. An external constant determines the amplification for the input signal.
- **Input gain:**
The input signal can be amplified by 0 to +30 dB in 2-dB steps.
- **Bass control:**
The bass can be controlled over a ±10 dB range in 2-dB steps.

Features

- Built-in buffer amplifiers reduce the number of external parts required.
- Silicon gate CMOS process reduces the noise of built-in switch.
- Built-in analog ground reference voltage generator circuit
- All functions are controlled by serial input data. This IC supports the CCB standard.

Package Dimensions

unit: mm

3159-QFP64E

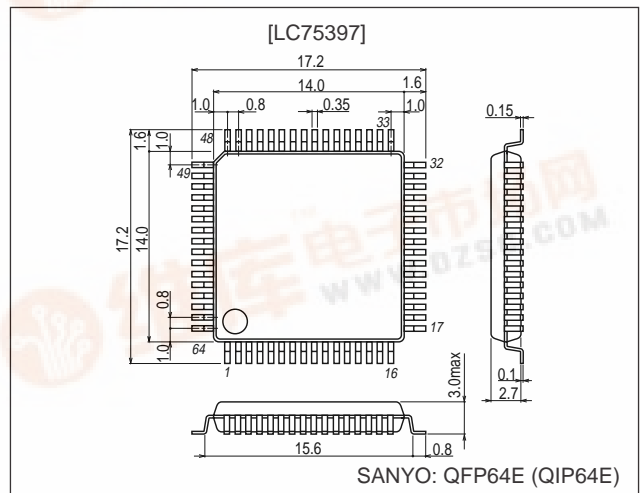

• CCB is a trademark of SANYO ELECTRIC CO., LTD.
• CCB is SANYO's original bus format and all the bus addresses are controlled by SANYO.

■ Any and all SANYO products described or contained herein do not have specifications that can handle applications that require extremely high levels of reliability, such as life-support systems, aircraft's control systems, or other applications whose failure can be reasonably expected to result in serious physical and/or material damage. Consult with your SANYO representative nearest you before using any SANYO products described or contained herein in such applications.

■ SANYO assumes no responsibility for equipment failures that result from using products at values that exceed, even momentarily, rated values (such as maximum ratings, operating condition ranges, or other parameters) listed in products specifications of any and all SANYO products described or contained herein.



LC75397E

Specifications

Absolute Maximum Ratings at $T_a = 25^\circ\text{C}$, $V_{SS} = 0\text{ V}$

Parameter	Symbol	Conditions	Ratings	Unit
Maximum supply voltage	$V_{DD\text{ max}}$	V_{DD}	11	V
Maximum input voltage	$V_{IN\text{ max}}$	CL, DI, CE, L1 to L6, R1 to R6, LTIN, RTIN, LVR1IN, RVR1IN, LVR2IN, RVR2IN, LVR3IN	$V_{SS} - 0.3$ to $V_{DD} + 0.3$	V
Allowable power dissipation	$Pd\text{ max}$	$T_a \leq 75^\circ\text{C}$, with PC board*	1000	mW
Operating temperature	T_{opr}		-30 to +75	$^\circ\text{C}$
Storage temperature	T_{stg}		-40 to +125	$^\circ\text{C}$

Note : * Printed circuit board size: $76.1 \times 114.3 \times 1.6\text{ mm}$, printed circuit board material: glass/Epoxy resin

Allowable Operating Ranges at $T_a = -30$ to $+75^\circ\text{C}$, $V_{SS} = 0\text{ V}$

Parameter	Symbol	Conditions	Ratings			Unit
			min	typ	max	
Supply voltage	V_{DD}	V_{DD}	6.0		10.5	V
Input high level voltage	V_{IH}	CL, DI, CE	4.0		V_{DD}	V
Input low level voltage	V_{IL}	CL, DI, CE	V_{SS}		1.0	V
Input voltage amplitude	V_{IN}	CL, DI, CE, L1 to L6, R1 to R6, LTIN, RTIN, LVR1IN, RVR1IN, LVR2IN, RVR2IN, LVR3IN	V_{SS}		V_{DD}	Vp-p
Input pulse width	t_{pw}	CL	1.0			μs
Setup time	t_{SETUP}	CL, DI, CE	1.0			μs
Hold time	t_{HOLD}	CL, DI, CE	1.0			μs
Operating frequency	f_{opg}	CL			500	kHz

Electrical Characteristics at $T_a = 25^\circ\text{C}$, $V_{DD} = 10\text{ V}$, $V_{SS} = 0\text{ V}$

Parameter	Symbol	Conditions	Ratings			Unit
			min	typ	max	
[Input block]						
Input resistance	R_{in}	L1 to L6, R1 to R6		50		$\text{k}\Omega$
Clipping level	V_{cl}	LSELO, RSELO: THD = 1.0%		3.00		V _{rms}
Output load resistance	R_L	LSELO, RSELO	10			$\text{k}\Omega$
[Volume control block]						
Input resistance	R_{in}	LVR1IN, RVR1IN, LVR2IN, RVR2IN, LVR3IN		50		$\text{k}\Omega$
[Bass control block]						
Control range	G_{eq}	Max, boost/cut	± 8	± 10	± 12	dB
Step resolution	E_{step}		1	2	3	dB
Internal feedback resistance	R_{bb1}			1.3		$\text{k}\Omega$
	R_{bb2}			58		
[F1/F2 band equalizer control block]						
Control range	G_{eq}	Max. boost/cut	± 8	± 10	± 12	dB
Step resolution	E_{step}		1	2	3	dB
Internal feedback resistor	R_{feed}		31	51.8	73	$\text{k}\Omega$
[F3/F4 band equalizer control block]						
Control range	G_{eq}	Max. boost/cut	± 8	± 10	± 12	dB
Step resolution	E_{step}		1	2	3	dB
Internal feedback resistor	R_{feed}		17	28	39	$\text{k}\Omega$
[Overall characteristics]						
Total harmonic distortion	THD	$V_{IN} = 1\text{ V}_{rms}$, $f = 1\text{ kHz}$, with all controls flat overall			0.01	%
Crosstalk	CT	$V_{IN} = 1\text{ V}_{rms}$, $f = 1\text{ kHz}$, with all controls flat overall, $R_g = 1\text{ k}\Omega$	80			dB
Output noise voltage	$V_N 1$	With all controls flat overall, 80 kHz, L.P.F		10.2		μV
	$V_N 2$	Bass band = +10dB, With all controls overall, 80 kHz, L.P.F		10.6		μV
Output at maximum attenuation	$V_O\text{ min}$	With all controls flat overall		-90		dB
Current drain	I_{DD}	$V_{DD} - V_{SS} = 10.5\text{ V}$		58		mA
Input high level current	I_{IH}	CL, DI, CE, $V_{IN} = 10.5\text{ V}$			10	μA
Input low level current	I_{IL}	CL, DI, CE, $V_{IN} = 0\text{ V}$	-10			μA

LC75397E

Pin Assignment

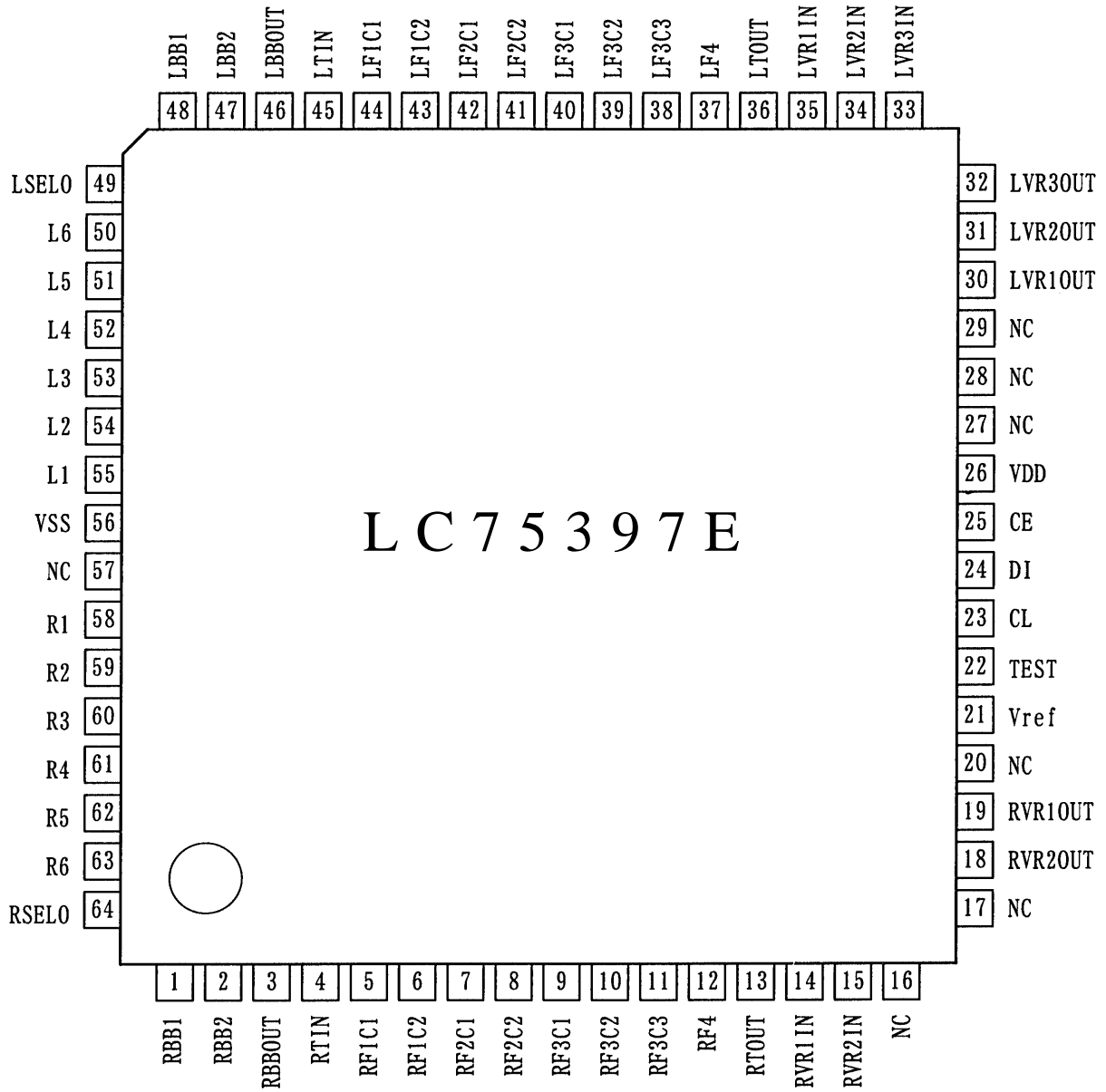

Top view

LC75397E

Sample Application Circuit

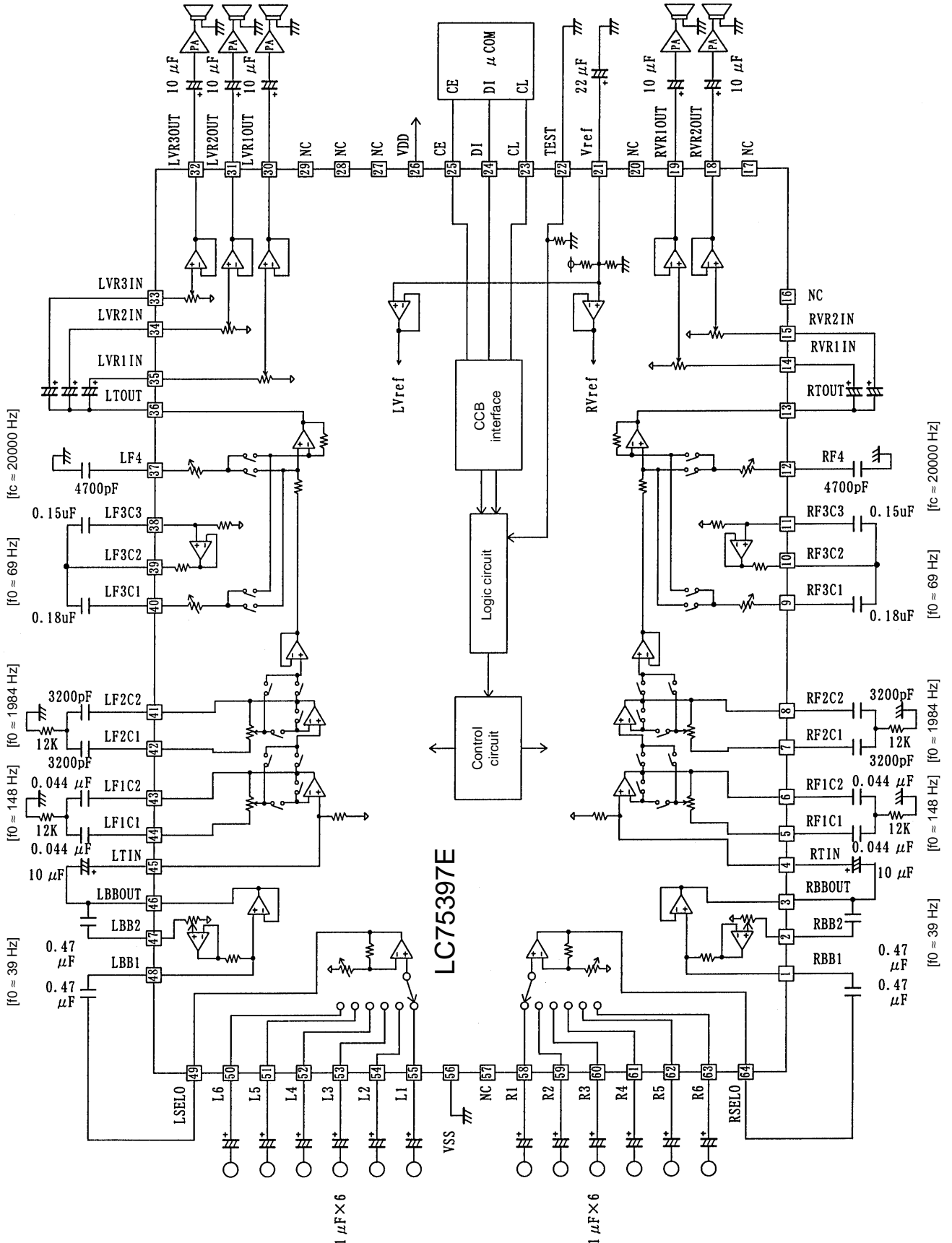

LC75397E

Control System Timing and Data Formats

To control the LC75397E, specified sequences are required to be input through the pins CE, CL, and DI. Each sequence consists of 48 bits: an 8-bit address followed by 56 bits of data.

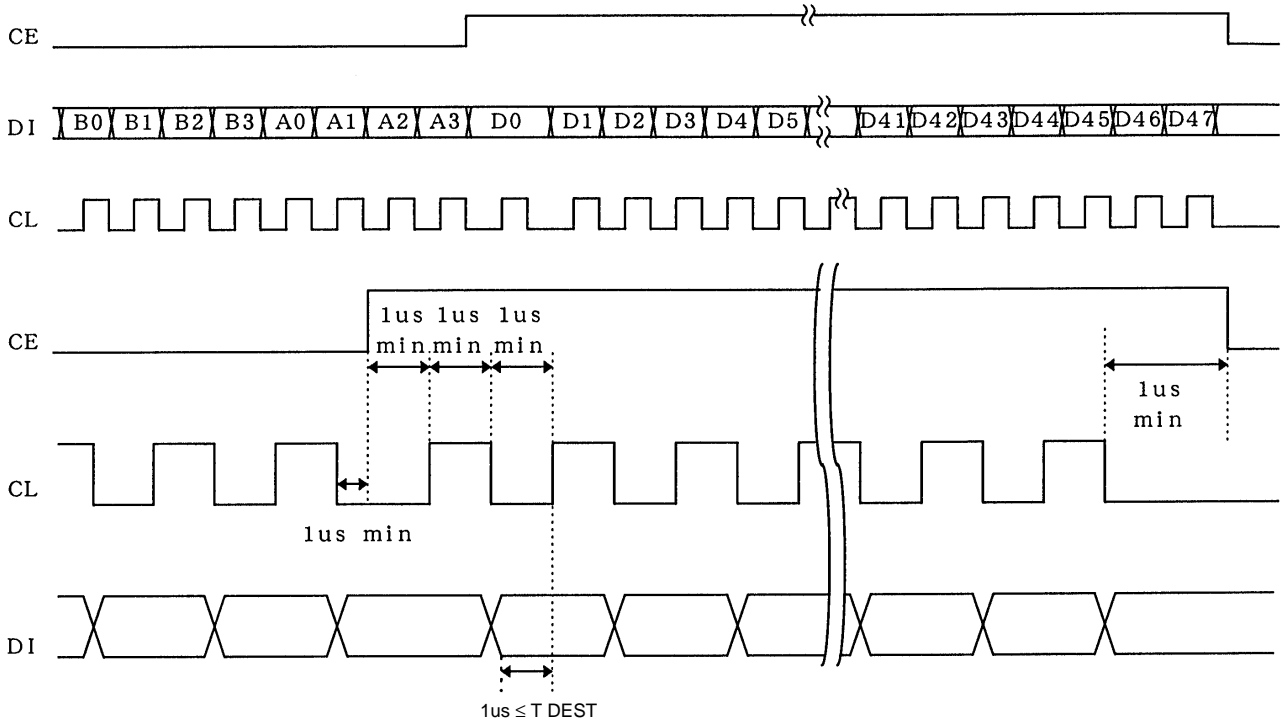

1. Address Code (B0 to A3)

This product uses an 8-bit address code, and supports the same specifications as other Sanyo CCB serial bus products.

Address code (LSB)

B0	B1	B2	B3	A0	A1	A2	A3
0	1	0	0	0	0	0	1

(82HEX)

2. Control Code Allocations

Input switching control
(L1, L2, L3, L4, L5,
R1, R2, R3, R4, R5)

D0	D1	D2	Operation	
0	0	0	L1 (R1)	ON
1	0	0	L2 (R2)	ON
0	1	0	L3 (R3)	ON
1	1	0	L4 (R4)	ON
0	0	1	L5 (R5)	OFF
1	0	1	Switch all	OFF
0	1	1	Switch all	OFF
1	1	1	Switch all	OFF

Input switching control
(L6, R6)

D3	Operation	
1	L6 (R6)	OFF
0	L6 (R6)	ON

LC75397E

Input gain control

D4	D5	D6	D7	Operation
0	0	0	0	0 dB
1	0	0	0	+2 dB
0	1	0	0	+4 dB
1	1	0	0	+6 dB
0	0	1	0	+8 dB
1	0	1	0	+10 dB
0	1	1	0	+12 dB
1	1	1	0	+14 dB
0	0	0	1	+16 dB
1	0	0	1	+18 dB
0	1	0	1	+20 dB
1	1	0	1	+22 dB
0	0	1	1	+24 dB
1	0	1	1	+26 dB
0	1	1	1	+28 dB
1	1	1	1	+30 dB

Bass and 4-band equalizer control

D8	D9	D10	D11	Bus
D12	D13	D14	D15	f1 band
D16	D17	D18	D19	f2 band
D20	D21	D22	D23	f3 band
D24	D25	D26	D27	f4 band
1	0	1	0	+10 dB
0	0	1	0	+8 dB
1	1	0	0	+6 dB
0	1	0	0	+4 dB
1	0	0	0	+2 dB
0	0	0	0	0 dB
1	0	0	1	-2 dB
0	1	0	1	-4 dB
1	1	0	1	-6 dB
0	0	1	1	-8 dB
1	0	1	1	-10 dB

LC75397E

Volume control

D28	D29	D30	D31	D32	D33	D34	D35	Operation
0	0	0	0	0	0	0	0	0 dB
1	0	0	0	0	0	0	0	-1 dB
0	1	0	0	0	0	0	0	-2 dB
1	1	0	0	0	0	0	0	-3 dB
0	0	1	0	0	0	0	0	-4 dB
1	0	1	0	0	0	0	0	-5 dB
0	1	1	0	0	0	0	0	-6 dB
1	1	1	0	0	0	0	0	-7 dB
0	0	0	1	0	0	0	0	-8 dB
1	0	0	1	0	0	0	0	-9 dB
0	1	0	1	0	0	0	0	-10 dB
1	1	0	1	0	0	0	0	-11 dB
0	0	1	1	0	0	0	0	-12 dB
1	0	1	1	0	0	0	0	-13 dB
0	1	1	1	0	0	0	0	-14 dB
1	1	1	1	0	0	0	0	-15 dB
0	0	0	0	1	0	0	0	-16 dB
1	0	0	0	1	0	0	0	-17 dB
0	1	0	0	1	0	0	0	-18 dB
1	1	0	0	1	0	0	0	-19 dB
0	0	1	0	1	0	0	0	-20 dB
1	0	1	0	1	0	0	0	-21 dB
0	1	1	0	1	0	0	0	-22 dB
1	1	1	0	1	0	0	0	-23 dB
0	0	0	1	1	0	0	0	-24 dB
1	0	0	1	1	0	0	0	-25 dB
0	1	0	1	1	0	0	0	-26 dB
1	1	0	1	1	0	0	0	-27 dB
0	0	1	1	1	0	0	0	-28 dB
1	0	1	1	1	0	0	0	-29 dB
0	1	1	1	1	0	0	0	-30 dB
1	1	1	1	1	0	0	0	-31 dB
0	0	0	0	0	1	0	0	-32 dB
1	0	0	0	0	1	0	0	-33 dB
0	1	0	0	0	1	0	0	-34 dB
1	1	0	0	0	1	0	0	-35 dB
0	0	1	0	0	1	0	0	-36 dB
1	0	1	0	0	1	0	0	-37 dB
0	1	1	0	0	1	0	0	-38 dB
1	1	1	0	0	1	0	0	-39 dB
0	0	0	1	0	1	0	0	-40 dB
1	0	0	1	0	1	0	0	-41 dB
0	1	0	1	0	1	0	0	-42 dB
1	1	0	1	0	1	0	0	-43 dB
0	0	1	1	0	1	0	0	-44 dB
1	0	1	1	0	1	0	0	-45 dB
0	1	1	1	0	1	0	0	-46 dB
1	1	1	1	0	1	0	0	-47 dB
0	0	0	0	1	1	0	0	-48 dB
1	0	0	0	1	1	0	0	-49 dB
0	1	0	0	1	1	0	0	-50 dB

Continued on next page.

LC75397E

Continued from preceding page.

D28	D29	D30	D31	D32	D33	D34	D35	Operation
1	1	0	0	1	1	0	0	-51 dB
0	0	1	0	1	1	0	0	-52 dB
1	0	1	0	1	1	0	0	-53 dB
0	1	1	0	1	1	0	0	-54 dB
1	1	1	0	1	1	0	0	-55 dB
0	0	0	1	1	1	0	0	-56 dB
1	0	0	1	1	1	0	0	-57 dB
0	1	0	1	1	1	0	0	-58 dB
1	1	0	1	1	1	0	0	-59 dB
0	0	1	1	1	1	0	0	-60 dB
1	0	1	1	1	1	0	0	-61 dB
0	1	1	1	1	1	0	0	-62 dB
1	1	1	1	1	1	0	0	-63 dB
0	0	0	0	0	0	1	0	-64 dB
1	0	0	0	0	0	1	0	-65 dB
0	1	0	0	0	0	1	0	-66 dB
1	1	0	0	0	0	1	0	-67 dB
0	0	1	0	0	0	1	0	-68 dB
1	0	1	0	0	0	1	0	-69 dB
0	1	1	0	0	0	1	0	-70 dB
1	1	1	0	0	0	1	0	-71 dB
0	0	0	1	0	0	1	0	-72 dB
1	0	0	1	0	0	1	0	-73 dB
0	1	0	1	0	0	1	0	-74 dB
1	1	0	1	0	0	1	0	-75 dB
0	0	1	1	0	0	1	0	-76 dB
1	0	1	1	0	0	1	0	-77 dB
0	1	1	1	0	0	1	0	-78 dB
1	1	1	1	0	0	1	0	-79 dB
0	0	0	0	1	0	1	0	-∞

Channel selection control

D36	D37	Operation
0	0	Initial setting
1	0	Right channel
0	1	Left channel
1	1	Simultaneous left and right

Volume 1 control

D38	Operation
0	Control off
1	Control enabled

Right channel control is enabled when D36 is set to 1.
Left channel control is enabled when D37 is set to 1.

Volume 2 control

D39	Operation
0	Control off
1	Control enabled

Right channel control is enabled when D36 is set to 1.
Left channel control is enabled when D37 is set to 1.

Volume 3 control

D40	Operation
0	Control off
1	Control enabled

Control of this function is enabled when D37 is set to 1.

Test mode control

D41	D42	D43	D44	D45	D46	D47
0	0	0	0	0	0	0

These bits are for chip testing and must all be set to 0 in application systems.

LC75397E

Pin Functions

Pin No.	Pin	Function	Equivalent circuit
55 54 53 52 51 50 58 59 60 61 62 63	L1 L2 L3 L4 L5 L6 R1 R2 R3 R4 R5 R6	Signal inputs	
49 64	LSELO RSELO	Input selector outputs	
48 47 1 2 46 3	LBB1 LBB2 RBB1 RBB2 LBBOUT RBBOUT	Bass circuit inputs and outputs	
45 4	LTIN RTIN	Equalizer inputs	
44 43 5 6	LF1C1 LF1C2 RF1C1 RF1C2	Connections for the resistors and capacitors that form the F1 band equalizer.	
42 41 7 8	LF2C1 LF2C2 RF2C1 RF2C2	Connections for the resistors and capacitors that form the F2 band equalizer.	

Continued on next page.

LC75397E

Continued from preceding page.

Pin No.	Pin	Function	Equivalent circuit
37 12	LF4 RF4	Connections for the capacitors that form the equalizer F4 band filters Connections for external capacitors	
40 39 38 9 10 11	LF3C1 LF3C2 LF3C3 RF3C1 RF3C2 RF3C3	Connections for the resistors and capacitors that form the F3 band equalizer.	
36 13	LTOUT RTOUT	Connections for the resistors and capacitors that form the F3 band equalizer.	
35 34 33 14 15	LVR1IN LVR2IN LVR3IN RVR1IN RVR2IN	<ul style="list-style-type: none"> • Left channel volume input 1 • Left channel volume input 2 • Left channel volume input 3 • Right channel volume input 1 • Right channel volume input 2 	
32 31 30 18 19	LVR3OUT LVR2OUT LVR1OUT RVR2OUT RVR1OUT	<ul style="list-style-type: none"> • Left channel volume output 3 • Left channel volume output 2 • Left channel volume output 1 • Right channel volume output 2 • Right channel volume output 1 	

Continued on next page.

LC75397E

Continued from preceding page.

Pin No.	Pin	Function	Equivalent circuit
21	Vref	<ul style="list-style-type: none"> A capacitor with a value of a few tens of μF must be inserted between Vref and AV_{SS} (V_{SS}) to reduce power supply ripple in the $0.5 \times V_{\text{DD}}$ voltage generator block used for analog ground. 	
56	V _{SS}	Ground	
26	V _{DD}	Power supply	
25	CE	<ul style="list-style-type: none"> Chip enable <p>When this pin goes from high to low, data is written to an internal latch and the analog switches operate. Data transfers are enabled when this pin is at the high level.</p>	
24 23	DI CL	<ul style="list-style-type: none"> Serial data and clock inputs for chip control 	
22	TEST	<ul style="list-style-type: none"> Electronic volume control test pin. <p>This pin must be held at the V_{SS} potential.</p>	
16 17 20 27 28 29 57	NC	<ul style="list-style-type: none"> Unused pins. These pins must either be left open or connected to V_{SS}. 	

Equivalent Circuit Diagram

(1) Selector Control Block

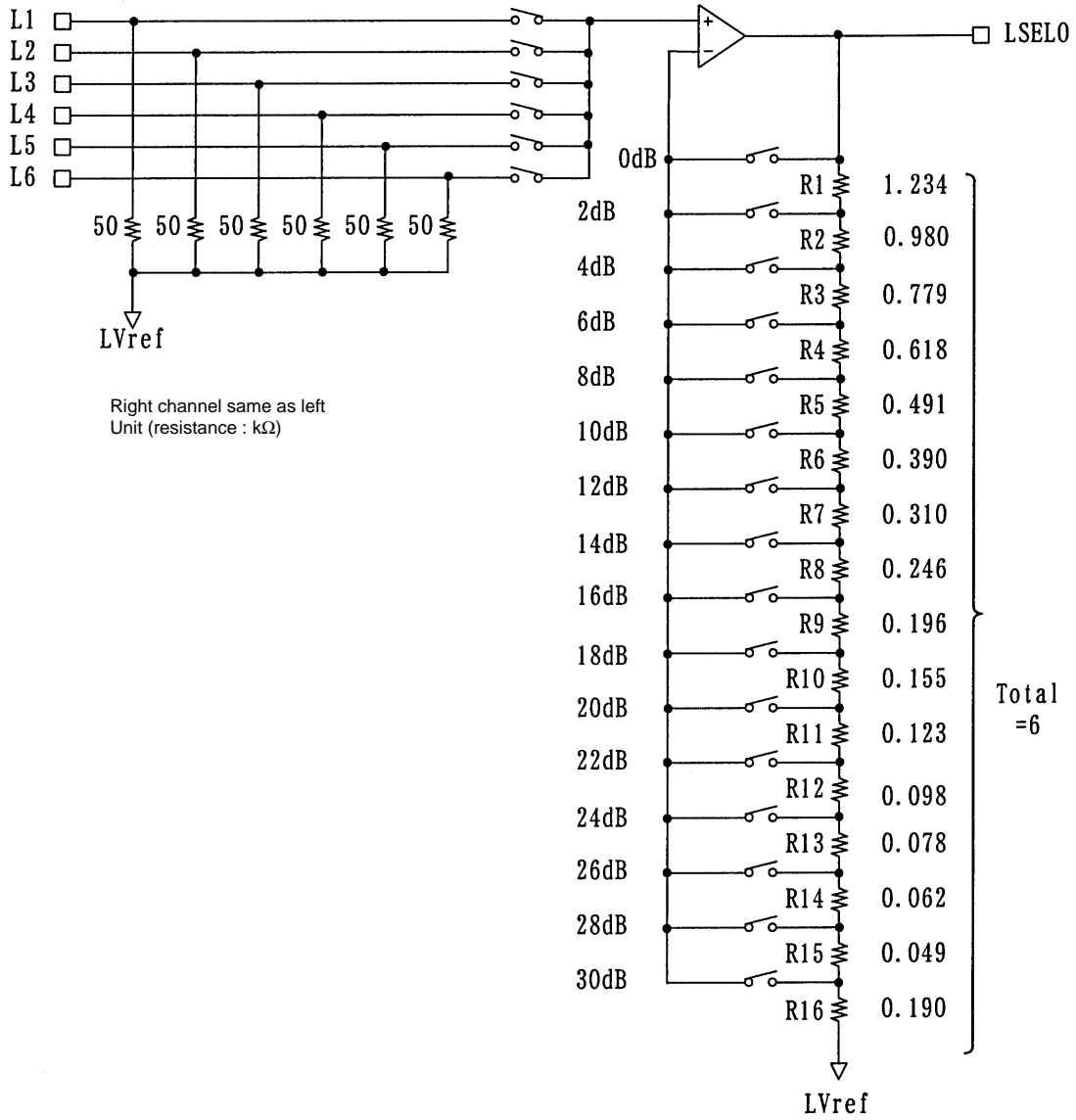

LC75397E

(2) Bass control block internal equivalent circuit

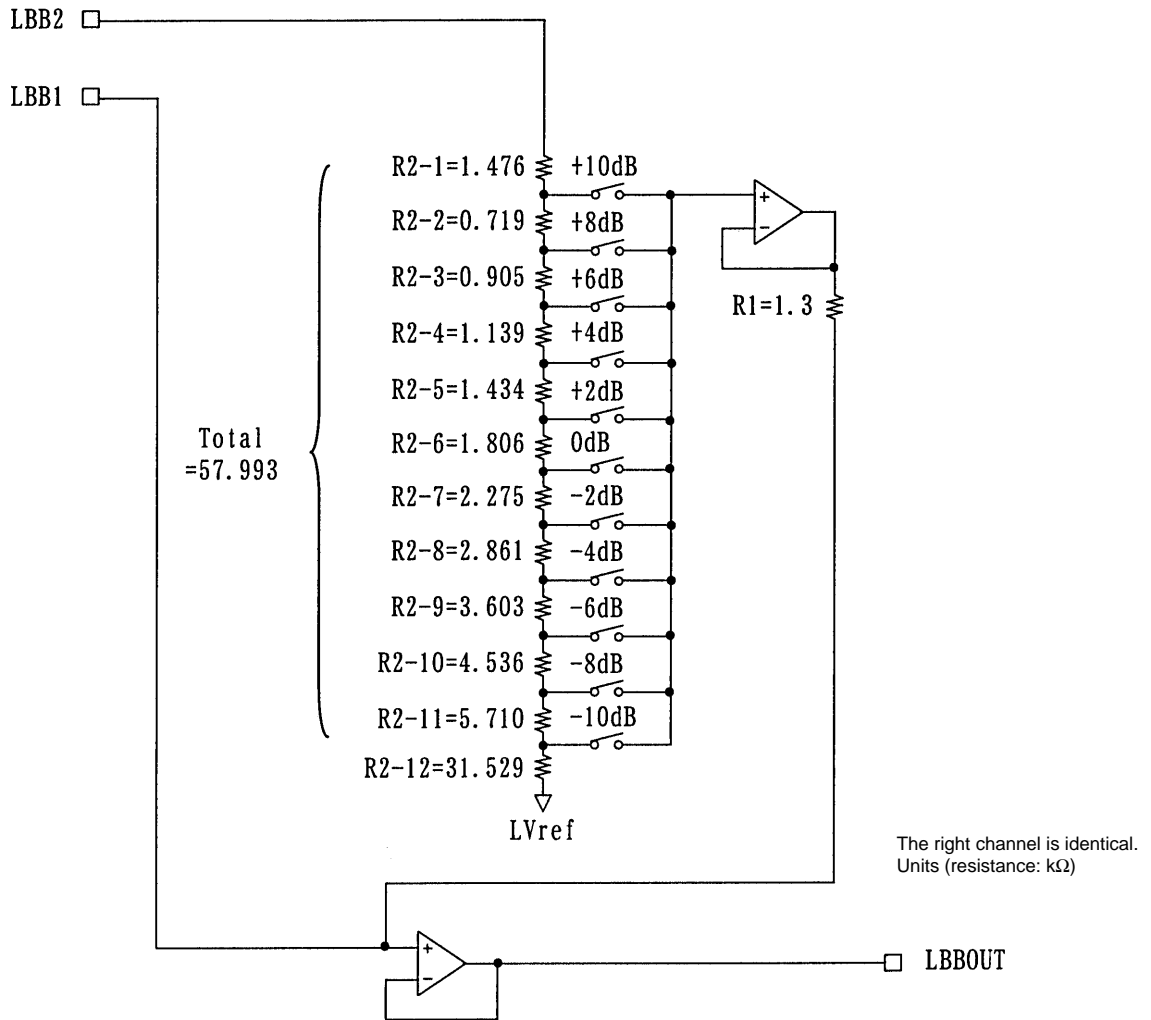

LC75397E

(3) F1/F2 band equalizer block internal equivalent circuit

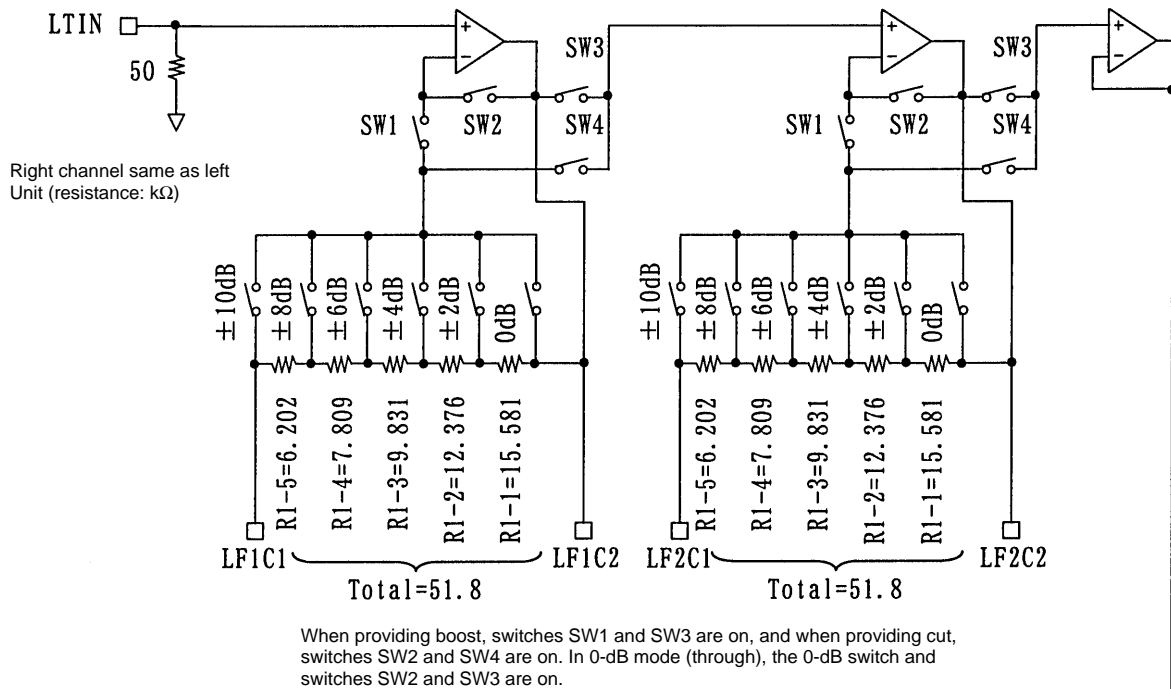

(4) F3/F4 band equalizer block internal equivalent circuit

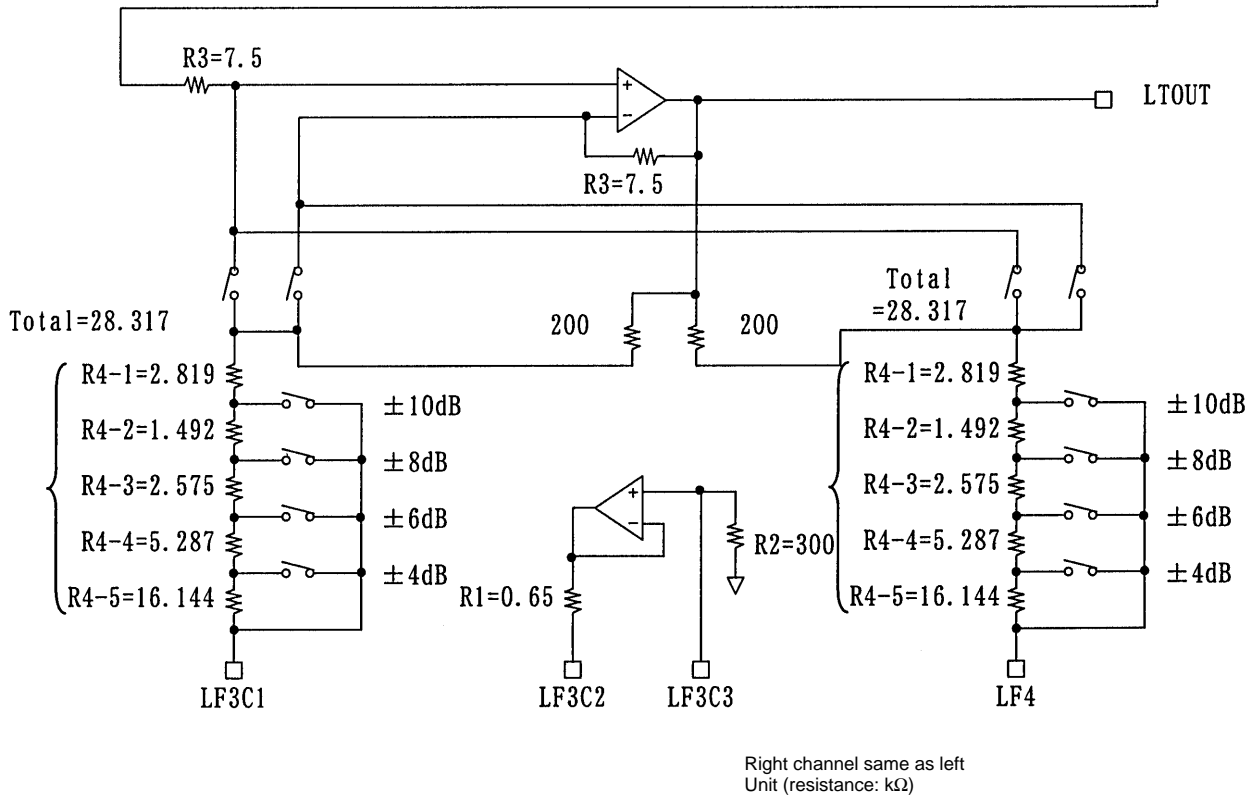

LC75397E

Volume block internal equivalent circuit

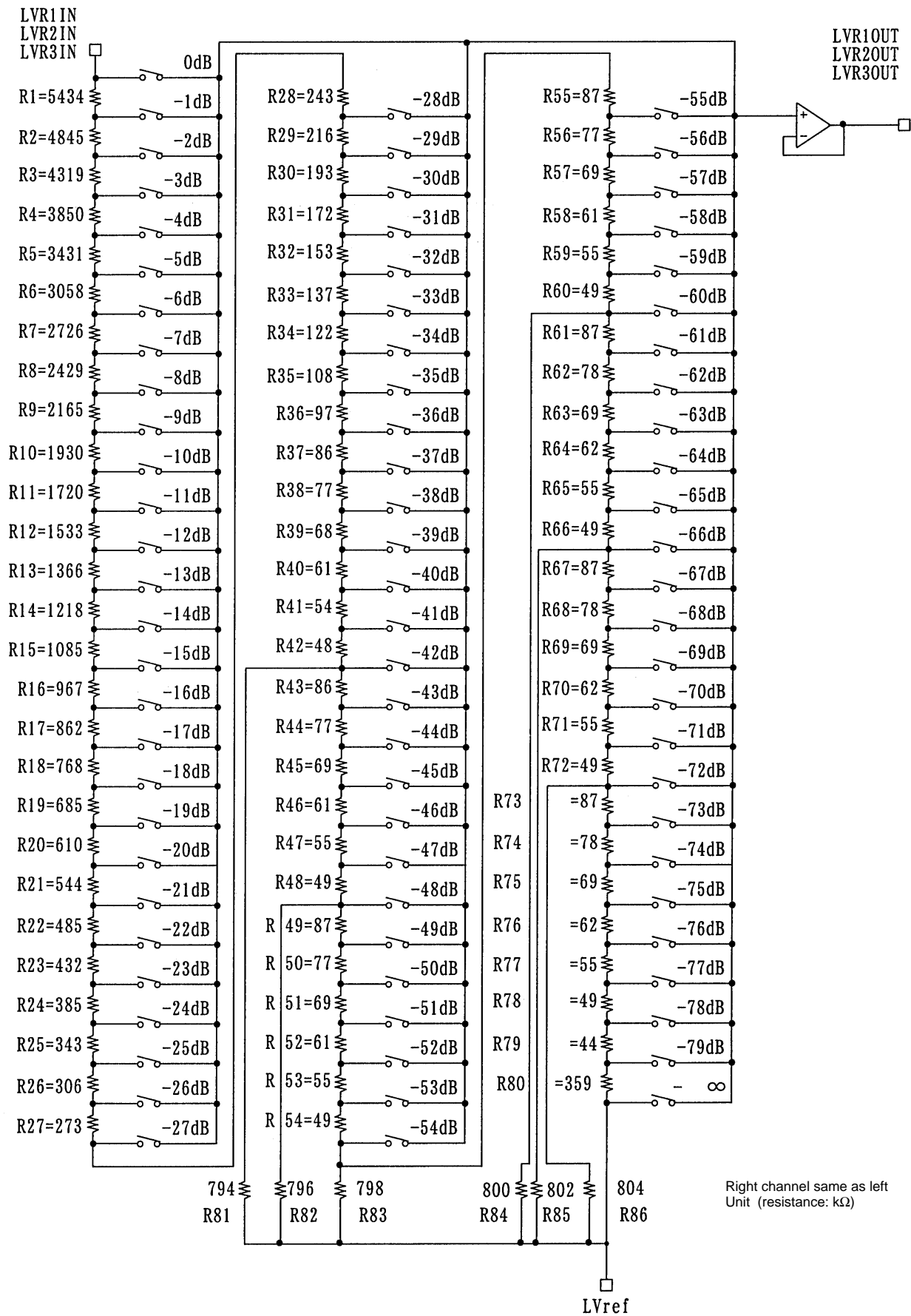

LC75397E

Test Circuits

Total Harmonic Distortion

The left channel is identical

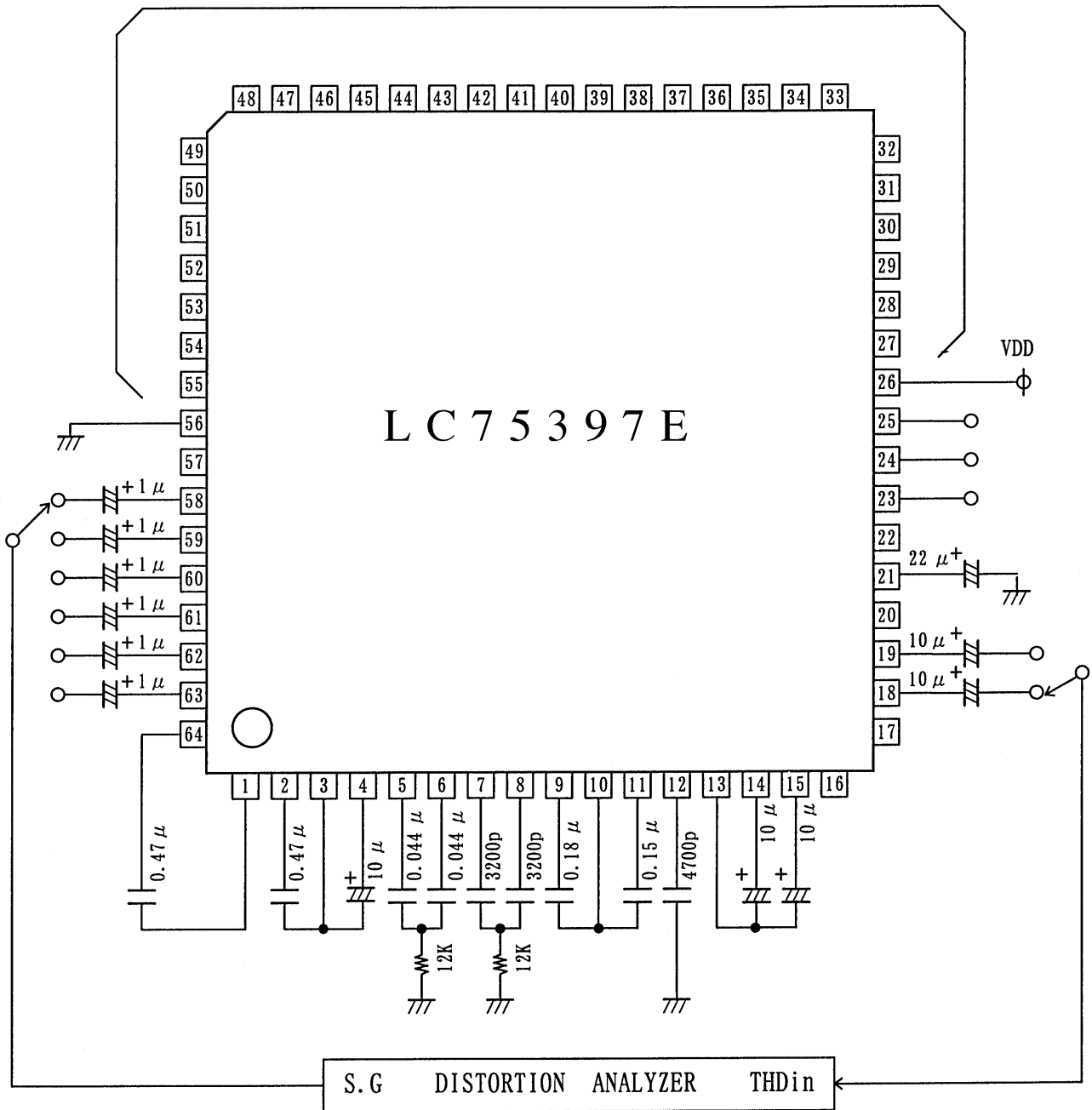

Unit (capacitance : F)

LC75397E

Output Noise Voltage

The left channel is identical

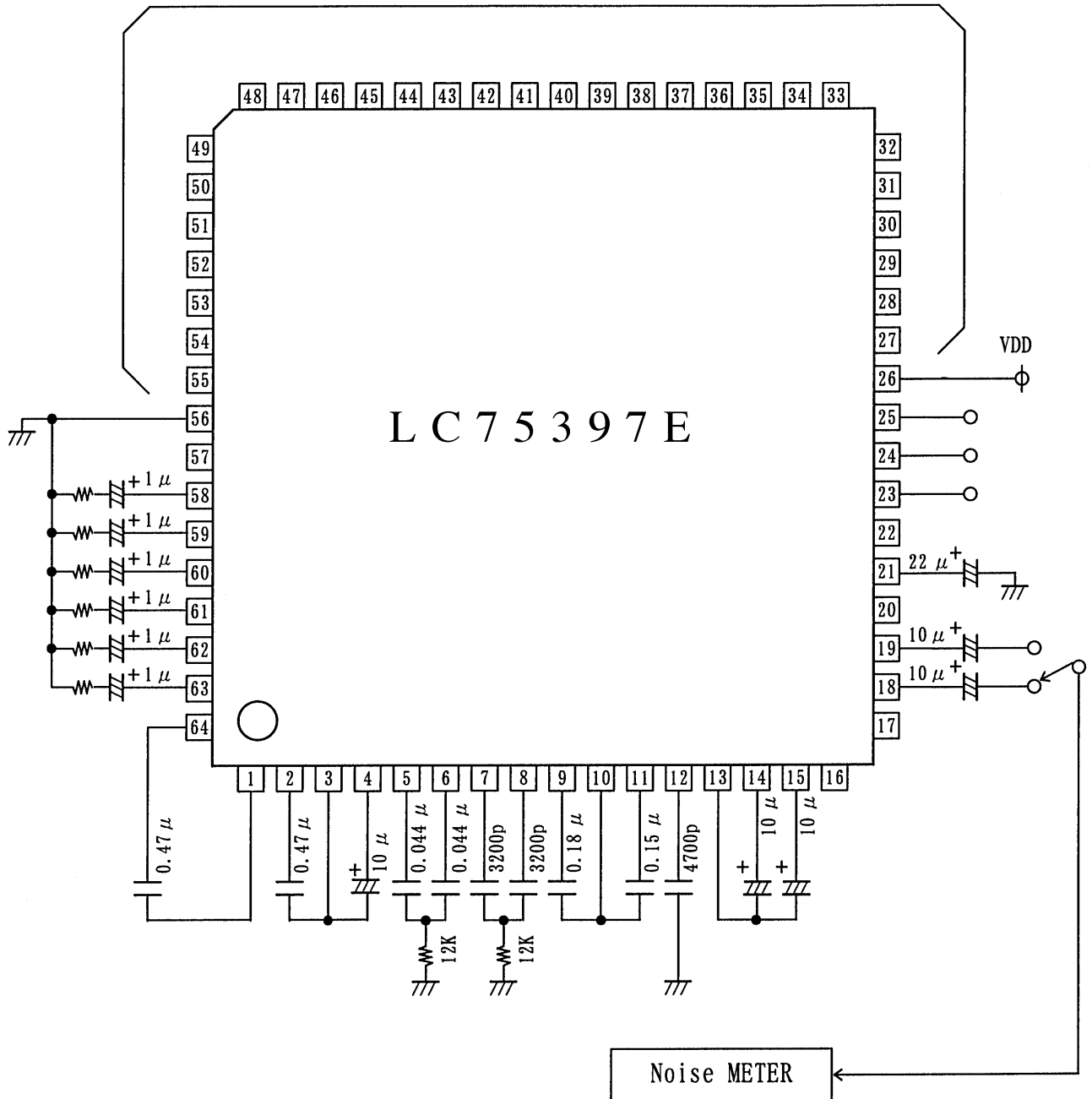

Unit (resistance : Ω, capacitance : F)

LC75397E

Crosstalk

The left channel is identical

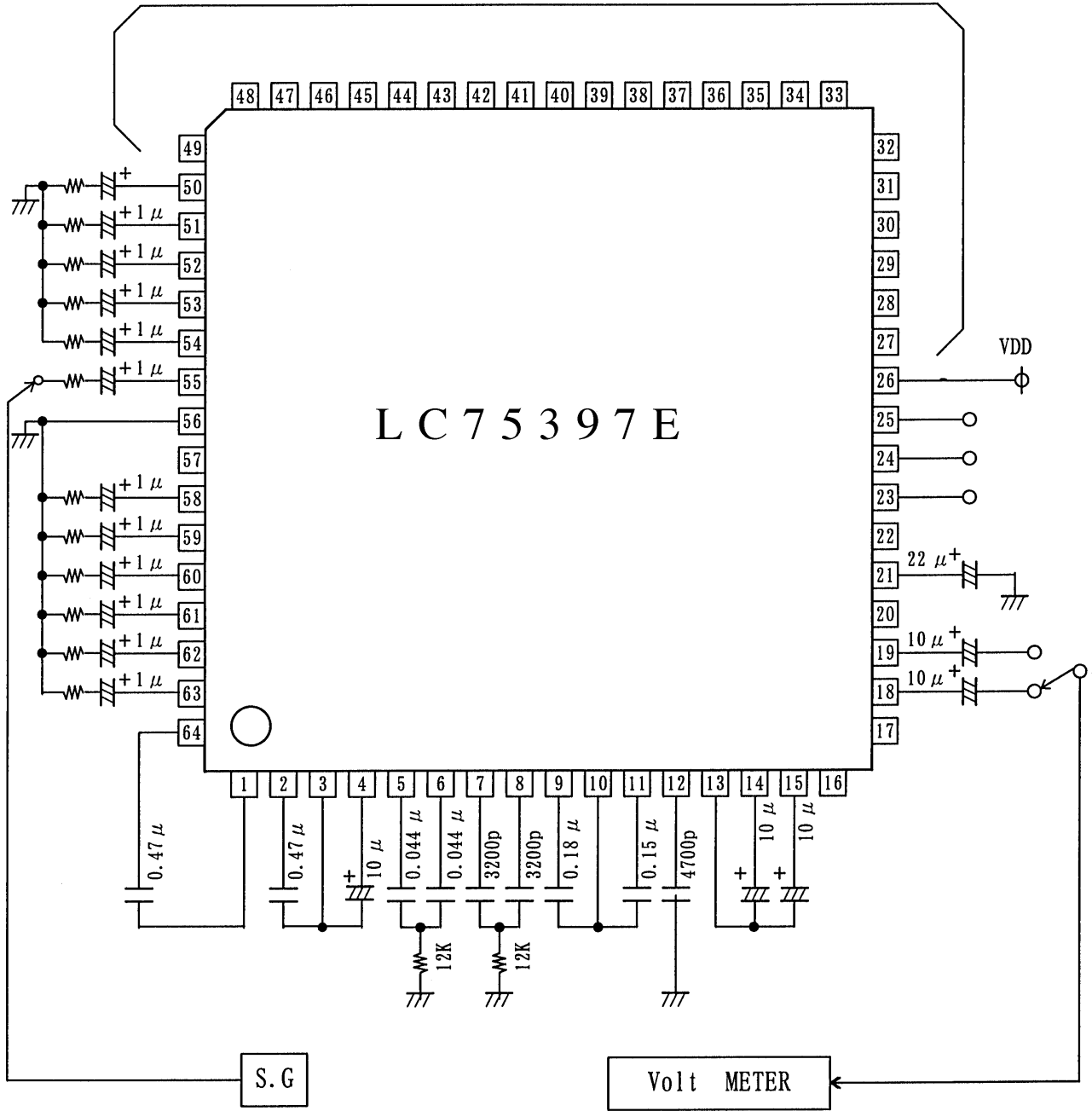

Unit (resistance : Ω, capacitance : F)

LC75397E

External Capacitor Calculations

1. Bass circuit

The value of the external capacitor used by the LC75397E bass control can be calculated as shown in the example below.

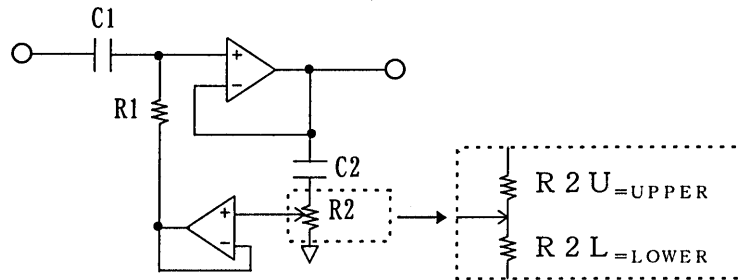

Sample calculation: For a center frequency f_0 of 39 Hz

Substitute the LC75397E internal resistors R_1 and R_2 shown below into the above formula.

This allows the value of the capacitor, C , to be calculated.

$$R_1 = 1.3 \text{ k}\Omega$$

$$R_2 = 57.993 \text{ k}\Omega$$

Assume $C_1 = C_2 = C$.

$$C = \frac{1}{2\pi f_0 \sqrt{R_1 R_2}}$$

$$C = \frac{1}{2\pi \times 39 \times \sqrt{1300 \times 58000}} \approx 0.47 \text{ }\mu\text{F}$$

Formula for calculating the gain:

$$R_1 = 1.3 \text{ k}\Omega$$

$$R_{2U} = 1.476 \text{ k}\Omega$$

$$R_{2L} = 56.517 \text{ k}\Omega$$

$$G = \sqrt{\left(\frac{R_1}{R_1 + R_{2U}}\right)^2 + \left(\frac{R_1 (R_{2U} + R_{2L})}{(R_1 + R_{2U}) \sqrt{R_1 (R_{2U} + R_{2L})}}\right)^2} = 3.16 = 10 \text{ dB}$$

Formula for calculating Q :

$$Q = \sqrt{\frac{R_1 (R_{2U} + R_{2L})}{(R_1 + R_{2U}) \sqrt{R_1 (R_{2U} + R_{2L})}}} \neq G$$

LC75397E

2. F1/F2 band circuits

This section presents the equivalent circuit and the formulas used to calculate the external resistor and capacitor values to provide a center frequency of 148 Hz.

- F1/F2 band equivalent circuit

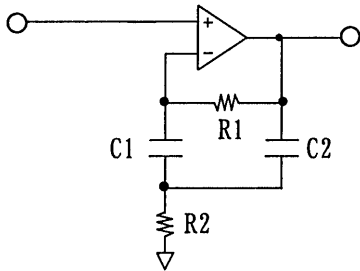

- Sample calculation

Specifications: Center frequency: $f_0 = 148$ Hz
 Gain at maximum boost: $G_{+10\text{dB}} = 10$ dB
 Assume $R_1 = 51.8$ k Ω and $C_1 = C_2 = C$.

(1) Determine R_2 from the specification that $G_{+10\text{dB}} = 10$ dB.

$$G_{+10\text{dB}} = 20 \times \text{LOG}_{10} \left(1 + \frac{R_1}{2R_2} \right)$$

$$R_2 = \frac{R_1}{2(10^{G_{+10\text{dB}}/20} - 1)} = \frac{51800}{2 \times (3.162 - 1)} = 11979.7 \approx 12 \text{ k}\Omega$$

(2) Determine C from the specification that the center frequency $f_0 = 148$ Hz.

$$f_0 = \frac{1}{2\pi f \sqrt{R_1 R_2 C_1 C_2}}$$

$$C = \frac{1}{2\pi f_0 \sqrt{R_1 R_2}} = \frac{1}{2\pi \times 148 \sqrt{51800 \times 12000}} = 0.0431 \times 10^{-6} \approx 0.044 \mu\text{F}$$

(3) Determine Q .

$$Q = \frac{C \cdot C \cdot R_1}{2C} \cdot \frac{1}{\sqrt{R_1 R_2 C C}} = \frac{51800}{2\sqrt{51800 \times 12000}} = 1.039$$

LC75397E

3. F3/F4 band circuits

The F3 band circuit supports peaking characteristics and the F4 band circuit supports shelving characteristics.

(1) Peaking characteristics (F3 band)

The external capacitor is used to construct a simulated inductor. This section presents the equivalent circuit and the formulas for determining the desired center frequency.

(a) Simulated inductor equivalent circuit

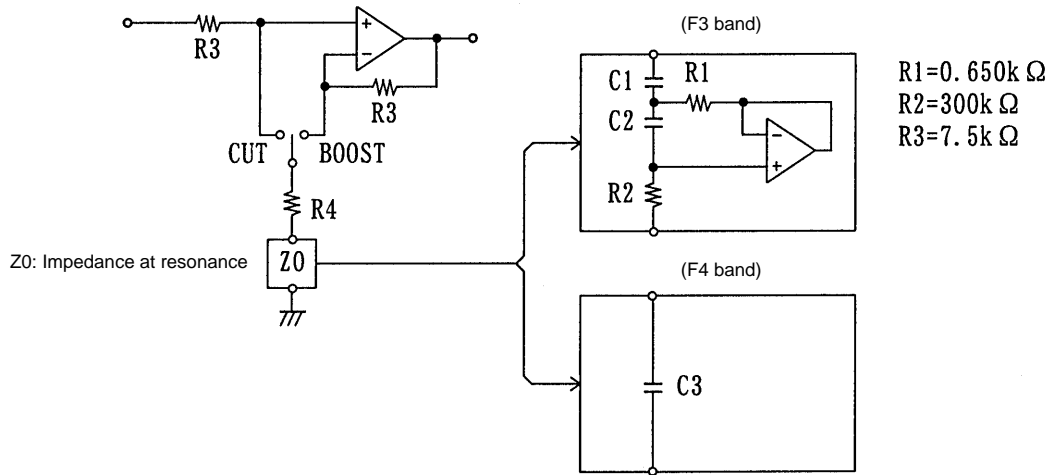

(b) Sample calculation

Specifications: 1) Center frequency: $f_0 = 107\text{ Hz}$
 2) Q at maximum boost: $Q_{+10\text{dB}} = 0.8$

(1) Determine the sharpness, Q_0 , of the simulated inductor itself.

$$Q_0 = (R1 + R4) / R1 \times Q_{+10\text{dB}} \approx 4.270$$

(2) Determine C1.

$$C1 = 1/2\pi f_0 R1 Q_0 \approx 0.536\ (\mu\text{F})$$

(3) Determine C2.

$$C2 = Q_0 / 2\pi f_0 R2 \approx 0.021\ (\mu\text{F})$$

(c) Reference values for C1 and C2

Center frequency f_0 (Hz)	C1 (F)	C2 (F)
107	0.536 μ	0.021 μ
340	0.169 μ	6663P
1070	0.054 μ	2117P
3400	0.017 μ	666P

(2) Shelving characteristics (F4 band)

Gains of $\pm 10\text{ dB}$ (in 2-dB steps) with respect to a target frequency can be achieved by using an external capacitor C3 with a calculated according to the formula F shown below.

LC75397E

Equivalent circuit and formula when boosting.

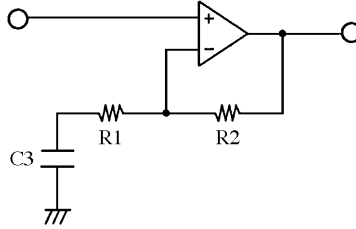

Sample calculation

Specifications: 1) Target frequency: $f = 17,000$ Hz
2) $R1 = 2,819$ k Ω , $R2 = 7.5$ k Ω

$$C = \frac{1}{2\pi f \sqrt{\left(\frac{R2}{10G/20 - 1}\right)^2 - R1^2}}$$
$$= \frac{1}{2\pi \times 17000 \sqrt{\left(\frac{7500}{3.16 - 1}\right)^2 - (2819)^2}}$$

≈ 4600 (pF)

Volume Step Characteristics

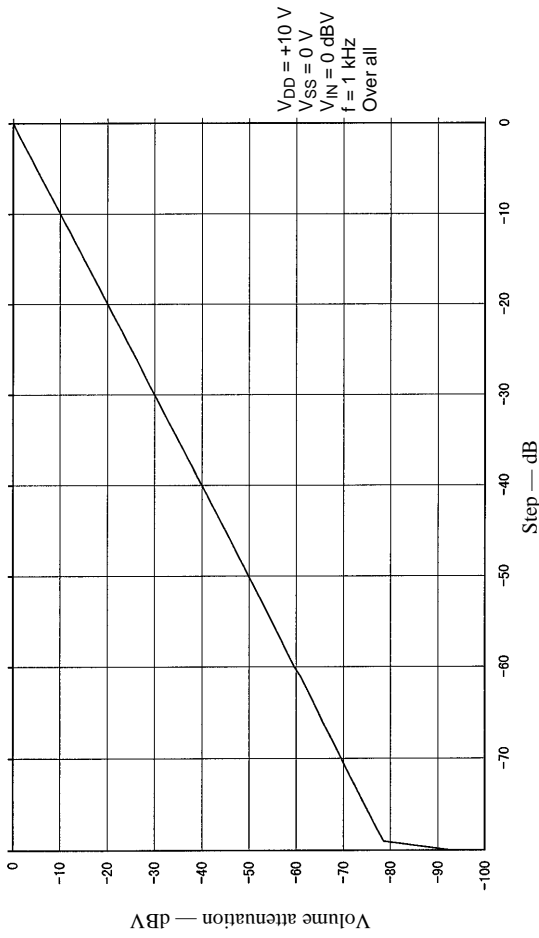

F1 Band Frequency Characteristics

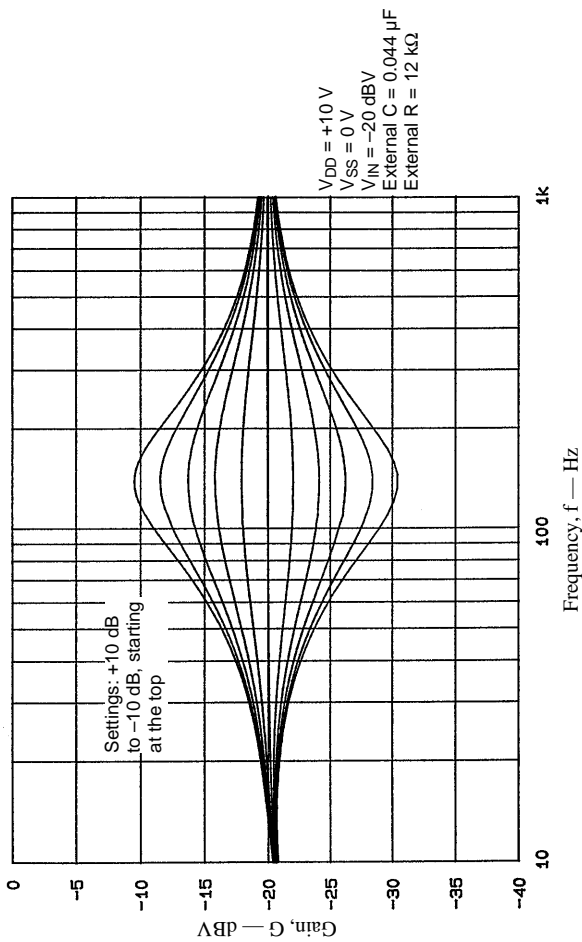

Bass Band Frequency Characteristics

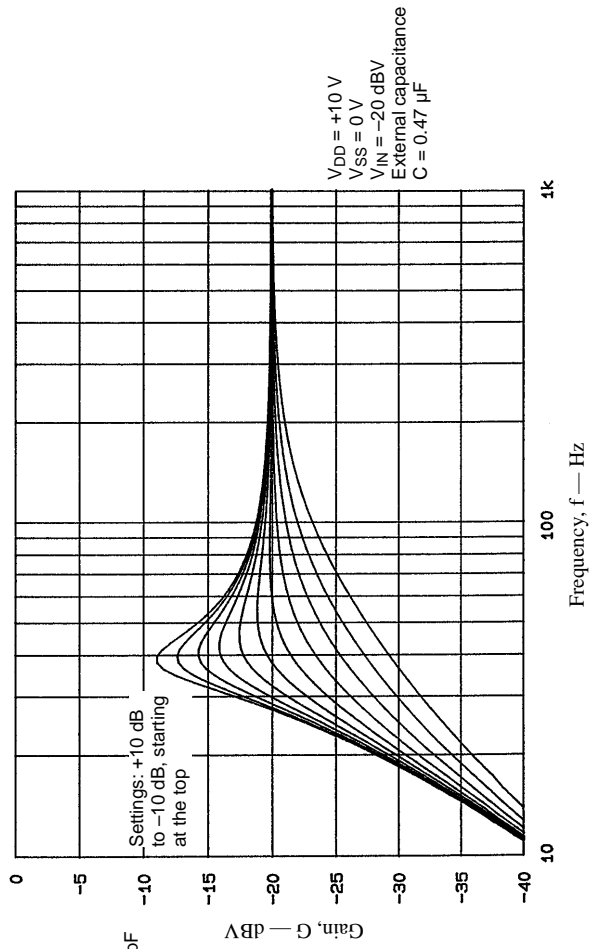

F2 Band Frequency Characteristics

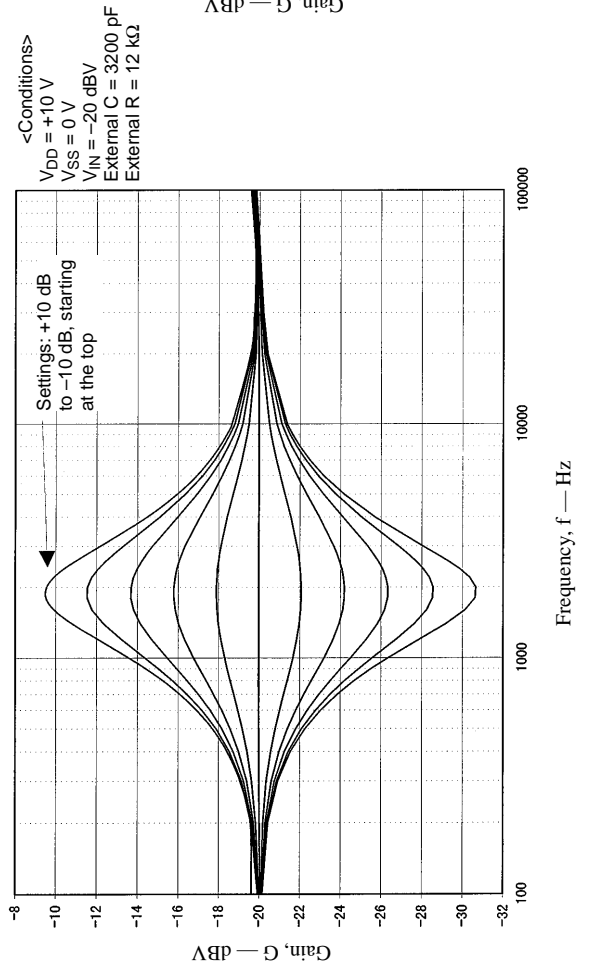

THD—Frequency Characteristics (1)

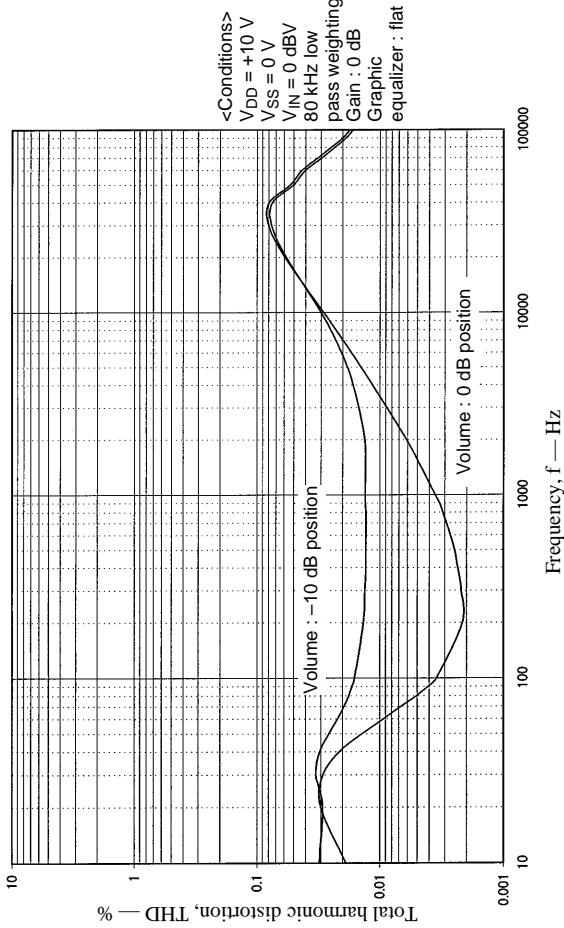

F3 Band Frequency Characteristics

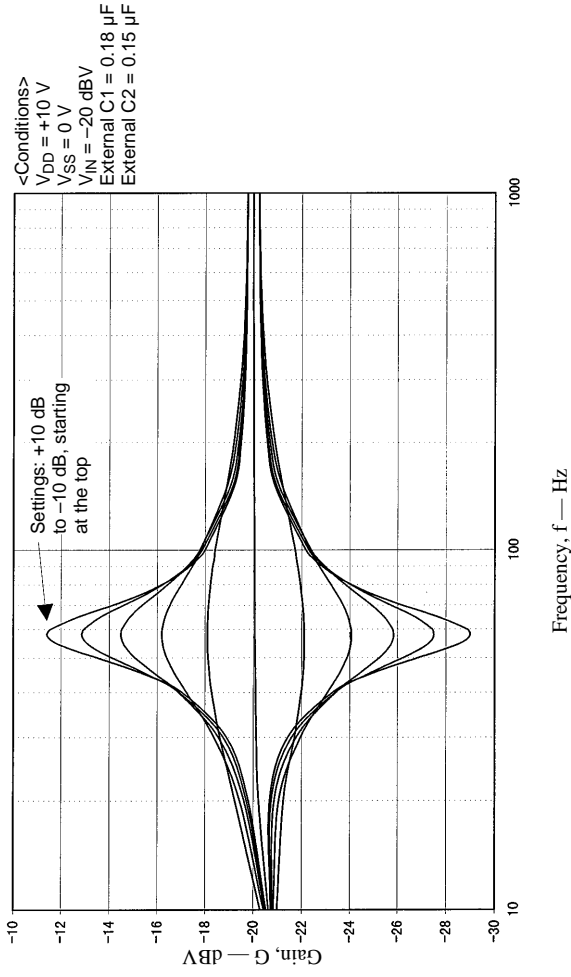

THD—Frequency Characteristics (2)

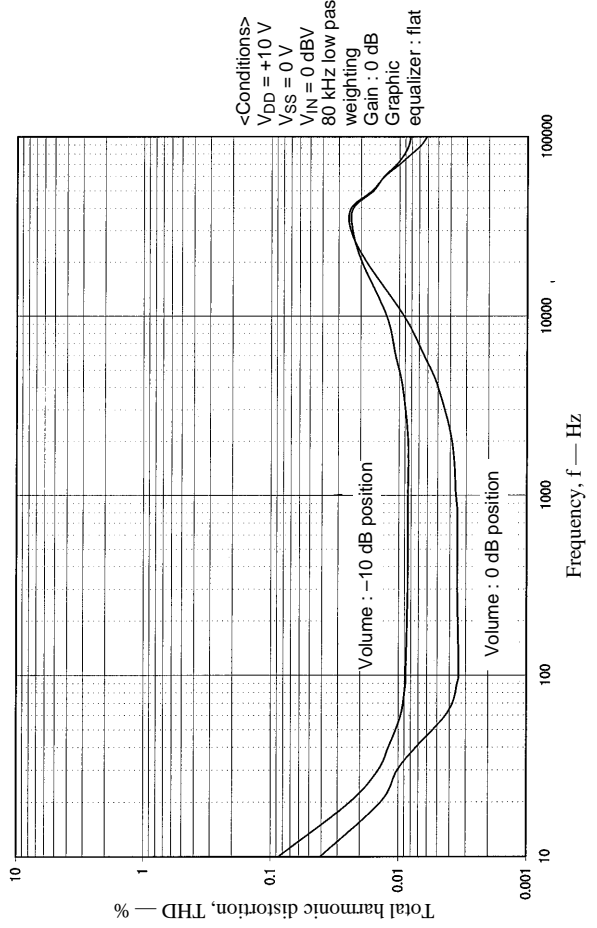

F4 Band Frequency Characteristics

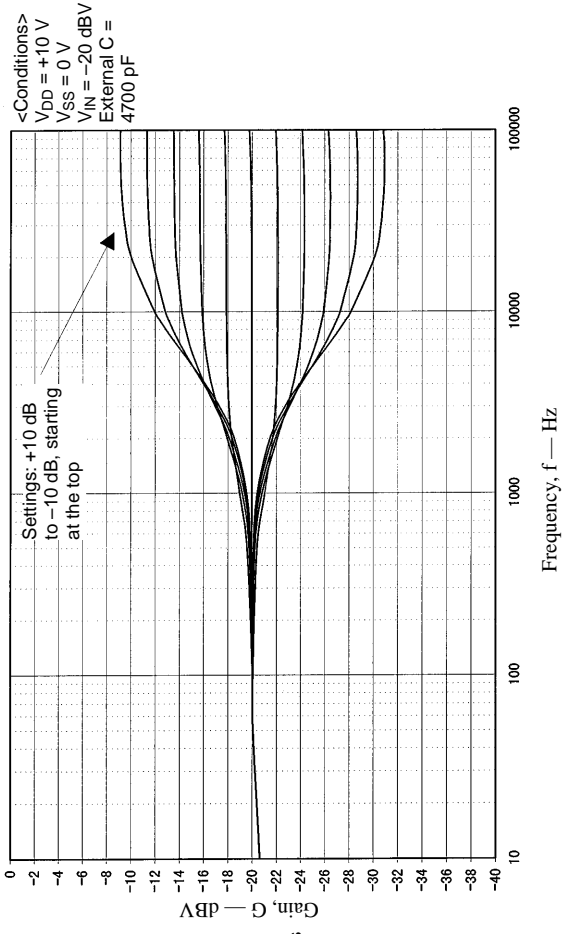

THD — Input Level Characteristics (1)

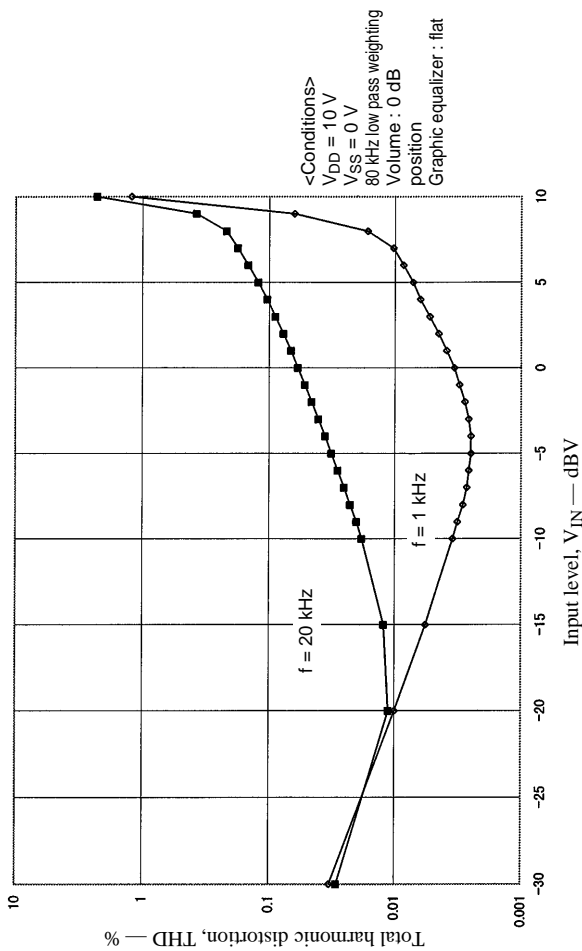

THD — Supply Voltage Characteristics (1)

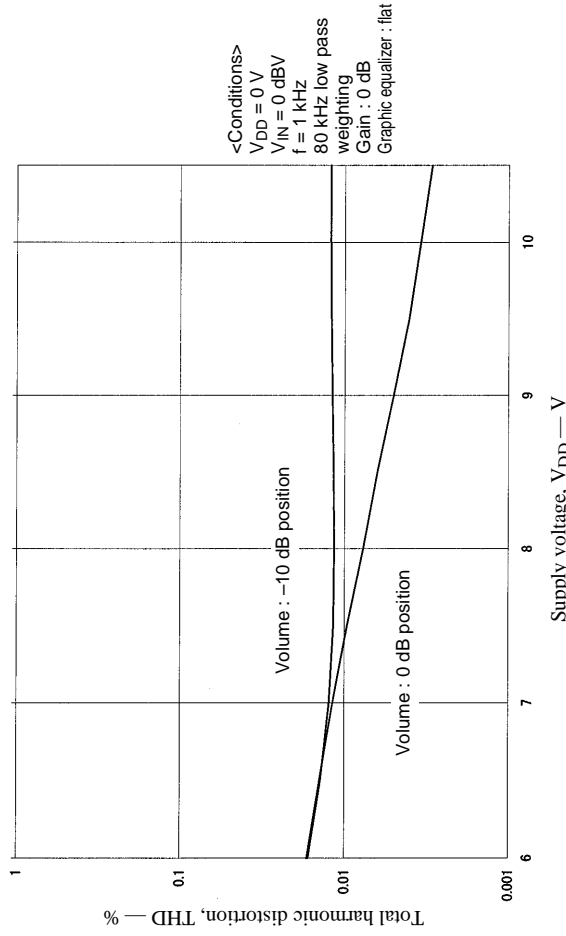

THD — Input Level Characteristics (2)

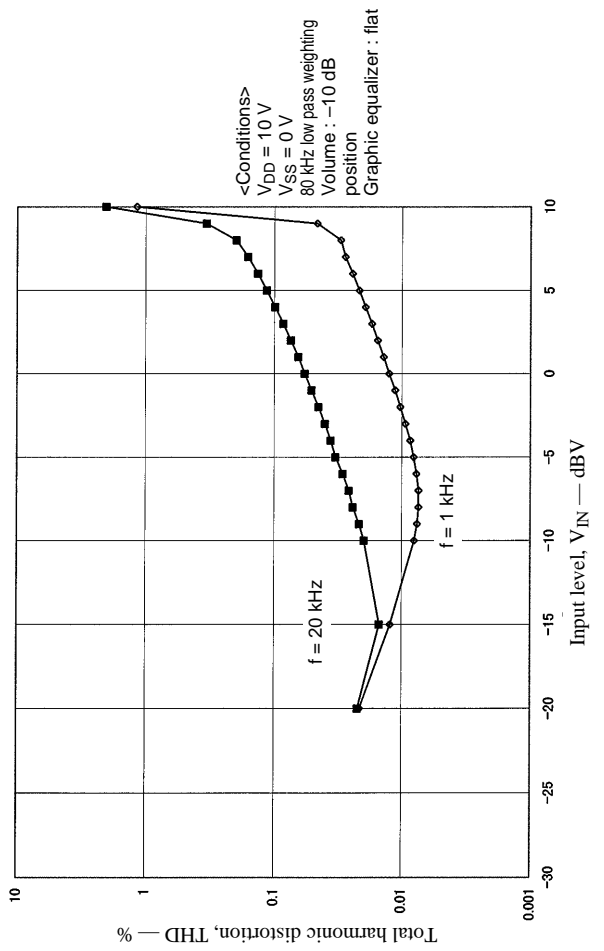

THD — Supply Voltage Characteristics (2)

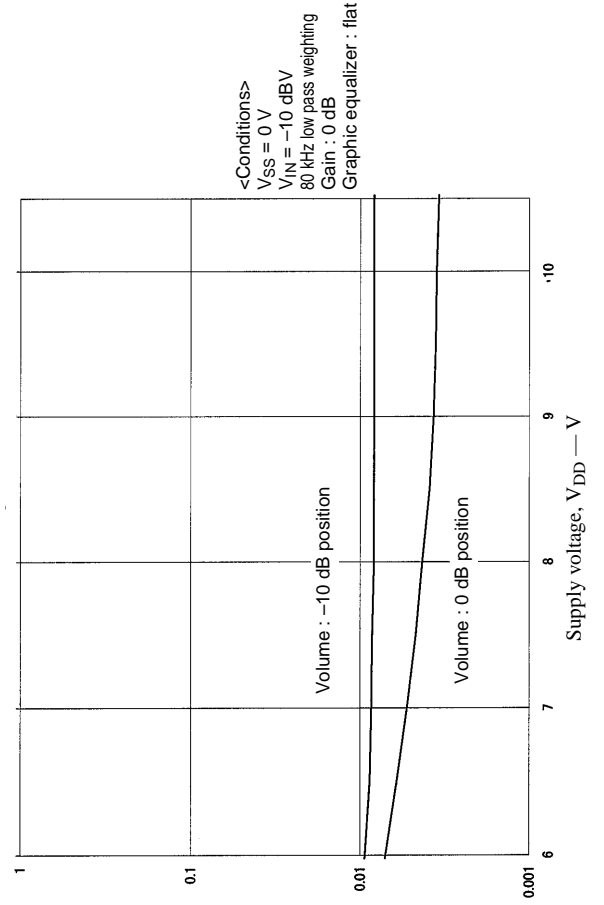

LC75397E

Usage Notes

- When the power is first applied, the internal analog switches are in indeterminate states. The chip therefore requires muting or other external measures until it has received the proper data.
- After power is first applied, applications must initialize this chip by sending the initial data (1) and (2) described below.
- Provide grounding patterns or shielding for the lines to the CL, DI, and CE pins so as to prevent their high-frequency digital signals from interfering with the operation of nearby analog circuits.

- Specifications of any and all SANYO products described or contained herein stipulate the performance, characteristics, and functions of the described products in the independent state, and are not guarantees of the performance, characteristics, and functions of the described products as mounted in the customer's products or equipment. To verify symptoms and states that cannot be evaluated in an independent device, the customer should always evaluate and test devices mounted in the customer's products or equipment.
- SANYO Electric Co., Ltd. strives to supply high-quality high-reliability products. However, any and all semiconductor products fail with some probability. It is possible that these probabilistic failures could give rise to accidents or events that could endanger human lives, that could give rise to smoke or fire, or that could cause damage to other property. When designing equipment, adopt safety measures so that these kinds of accidents or events cannot occur. Such measures include but are not limited to protective circuits and error prevention circuits for safe design, redundant design, and structural design.
- In the event that any or all SANYO products (including technical data, services) described or contained herein are controlled under any of applicable local export control laws and regulations, such products must not be exported without obtaining the export license from the authorities concerned in accordance with the above law.
- No part of this publication may be reproduced or transmitted in any form or by any means, electronic or mechanical, including photocopying and recording, or any information storage or retrieval system, or otherwise, without the prior written permission of SANYO Electric Co., Ltd.
- Any and all information described or contained herein are subject to change without notice due to product/technology improvement, etc. When designing equipment, refer to the "Delivery Specification" for the SANYO product that you intend to use.
- Information (including circuit diagrams and circuit parameters) herein is for example only; it is not guaranteed for volume production. SANYO believes information herein is accurate and reliable, but no guarantees are made or implied regarding its use or any infringements of intellectual property rights or other rights of third parties.