

Ordering number : EN5606

CMOS LSI



LC75725E

1/4 to 1/11 Duty Dynamic Drive VFD Driver



Overview

The LC75725E is a 1/4 to 1/11 duty dynamic drive VFD driver. It provides 43 segment outputs and 11 digit outputs. It facilitates the construction of display systems operating under the control of a controller.

Features

- Dynamic drive display technique to display four to eleven digits on the VFD.
- Serial data input supports CCB* format communication with the system controller.
- The dimmer level is controlled by serial data input. (The dimmer has a resolution of 10 bits.)
- High generality since display data is displayed without the intervention of a decoder.
- All segments can be turned off with the $\overline{\text{BLK}}$ pin.
- CR oscillator circuit.

Package Dimensions

unit: mm

3159-QFP64E

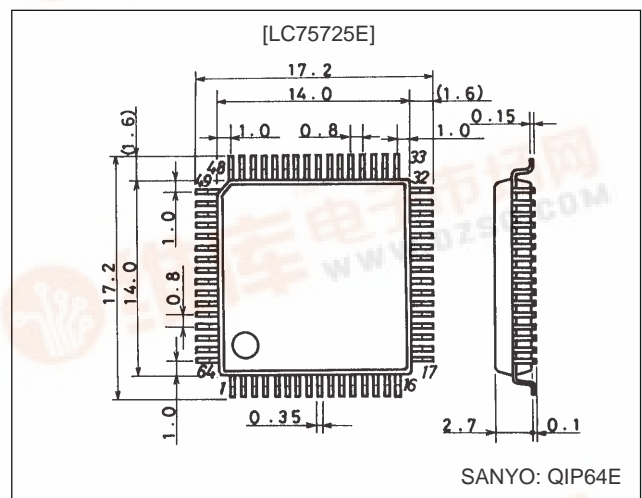

- CCB is a trademark of SANYO ELECTRIC CO., LTD.
- CCB is SANYO's original bus format and all the bus addresses are controlled by SANYO.

Specifications

Absolute Maximum Ratings at $T_a = 25^\circ\text{C}$, $V_{SS} = 0\text{V}$

Parameter	Symbol	Conditions	Ratings	Unit
Maximum supply voltage	$V_{DD\text{ max}}$	V_{DD}	-0.3 to +6.5	V
	$V_{FL\text{ max}}$	V_{FL}	$V_{DD} - 47$ to $V_{DD} + 0.3$	
Input voltage	V_{IN1}	DI, CL, CE, $\overline{\text{BLK}}$	-0.3 to +6.5	V
	V_{IN2}	OSCI	-0.3 to $V_{DD} + 0.3$	
Output voltage	V_{OUT1}	S1 to S43, G1 to G11	$V_{DD} - 47$ to $V_{DD} + 0.3$	V
	V_{OUT2}	OSCO	-0.3 to $V_{DD} + 0.3$	
Output current	I_{OUT1}	S1 to S43	10	mA
	I_{OUT2}	G1 to G11	30	
Allowable power dissipation	$P_{d\text{ max}}$	$T_a = 85^\circ\text{C}$	300	mW
Operating temperature	T_{opr}		-40 to +85	$^\circ\text{C}$
Storage temperature	T_{stg}		-50 to +150	$^\circ\text{C}$



LC75725E

Allowable Operating Ranges at $T_a = -40$ to $+85^\circ\text{C}$, $V_{DD} = 4.5$ to 5.5 V, $V_{SS} = 0$ V

Parameter	Symbol	Conditions	Ratings			Unit
			min	typ	max	
Supply voltage	V_{DD}	V_{DD}	4.5	5.0	5.5	V
	V_{FL}	V_{FL}	$V_{DD} - 45$		V_{DD}	
Input high-level voltage	V_{IH1}	DI, CL, CE, $\overline{\text{BLK}}$	$0.8 V_{DD}$		5.5	V
	V_{IH2}	OSCI	$0.8 V_{DD}$		V_{DD}	
Input low-level voltage	V_{IL}	DI, CL, CE, $\overline{\text{BLK}}$, OSCI	0		$0.2 V_{DD}$	V
Guaranteed oscillator range	f_{OSC}	OSCI, OSCO	1.8	3.7	4.9	MHz
Recommended external resistance	R_{OSC}	OSCI, OSCO	1.0	5.6	22	k Ω
Recommended external capacitance	C_{OSC}	OSCI, OSCO	10	22	47	pF
Low level clock pulse width	$t_{\phi L}$	CL Figure 1	0.5			μs
High level clock pulse width	$t_{\phi H}$	CL Figure 1	0.5			μs
Data setup time	t_{ds}	DI, CL Figure 1	0.5			μs
Data hold time	t_{dh}	DI, CL Figure 1	0.5			μs
CE wait time	t_{cp}	CE, CL Figure 1	0.5			μs
CE setup time	t_{cs}	CE, CL Figure 1	0.5			μs
CE hold time	t_{ch}	CE, CL Figure 1	0.5			μs
$\overline{\text{BLK}}$ switching time	t_c	$\overline{\text{BLK}}$, CE Figure 3	10			μs

Electrical Characteristics in the Allowable Operating Ranges

Parameter	Symbol	Conditions	Ratings			Unit
			min	typ	max	
Input high-level current	I_{IH1}	DI, CL, CE, $\overline{\text{BLK}}$: $V_I = 5.5$ V			5	μA
	I_{IH2}	OSCI: $V_I = V_{DD}$		5		
Input low-level current	I_{IL}	DI, CL, CE, $\overline{\text{BLK}}$: $V_I = 0$ V	-5			μA
Output high-level voltage	V_{OH1}	S1 to S43: $I_O = 5$ mA	$V_{DD} - 2.0$			V
	V_{OH2}	G1 to G11: $I_O = 20$ mA	$V_{DD} - 2.0$			
	V_{OH3}	OSCO: $I_O = 0.5$ mA	$V_{DD} - 2.0$			
Output low-level voltage	V_{OL}	OSCO: $I_O = -0.5$ mA			2.0	V
Output off voltage	V_{OFF}	S1 to S43, G1 to G11: $V_{FL} = V_{DD} - 45$ V, Outputs off			$V_{DD} - 44$	V
Pull-down resistors	R_{PD}	S1 to S43, G1 to G11: $V_{FL} = V_{DD} - 45$ V, $V_O = V_{DD}$	50	100	200	k Ω
Oscillator frequency	f_{OSC}	OSCI, OSCO: $R_{OSC} = 5.6$ k Ω , $C_{OSC} = 22$ pF		3.7		MHz
Hysteresis voltage	V_H	DI, CL, CE, $\overline{\text{BLK}}$		$0.1 V_{DD}$		V
Current drain	I_{DD}	V_{DD} : Outputs open. Display off, $f_{OSC} = 3.7$ MHz, $V_{FL} = V_{DD} - 45$ V			5	mA

LC75725E

1. When CL is stopped at the low level

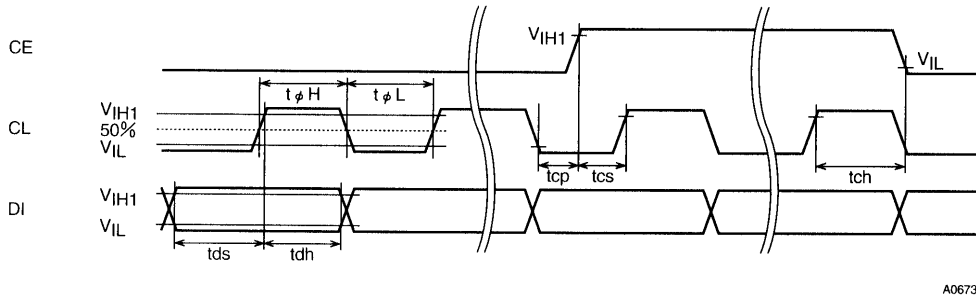

A06733

2. When CL is stopped at the high level

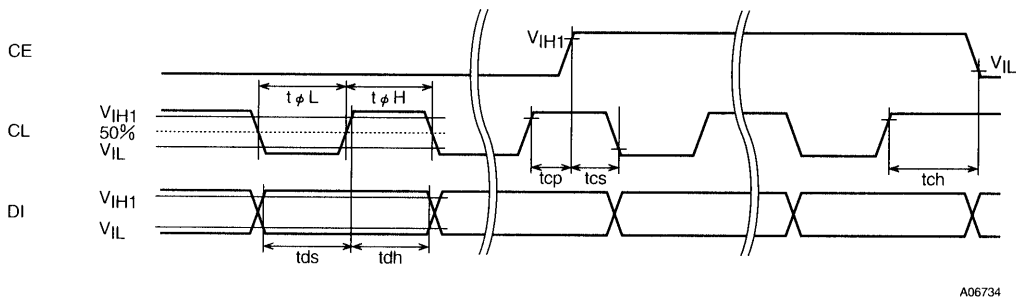

A06734

Figure 1

Pin Assignment

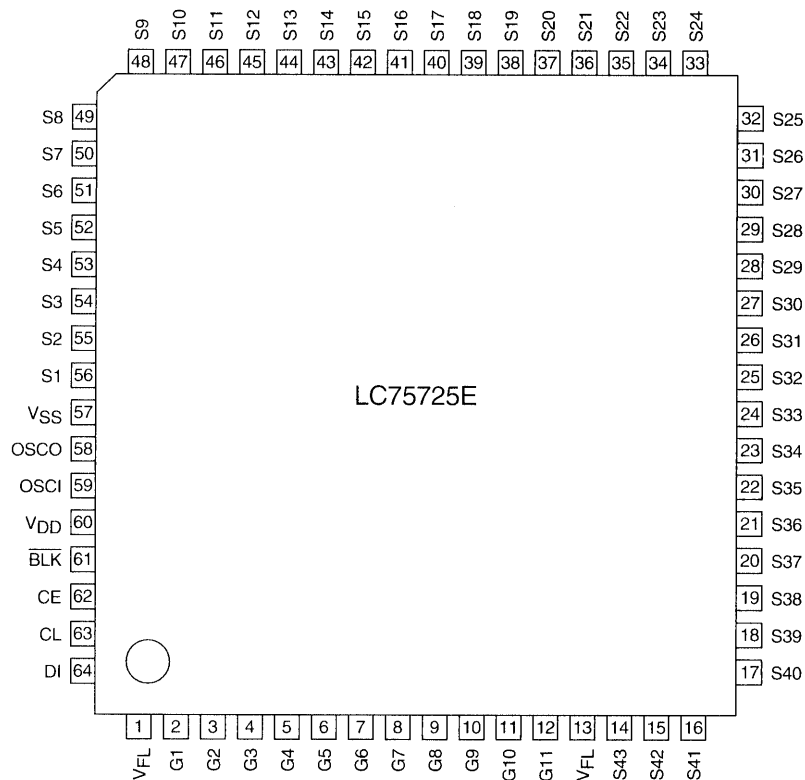

Top view

A06732

LC75725E

Block Diagram

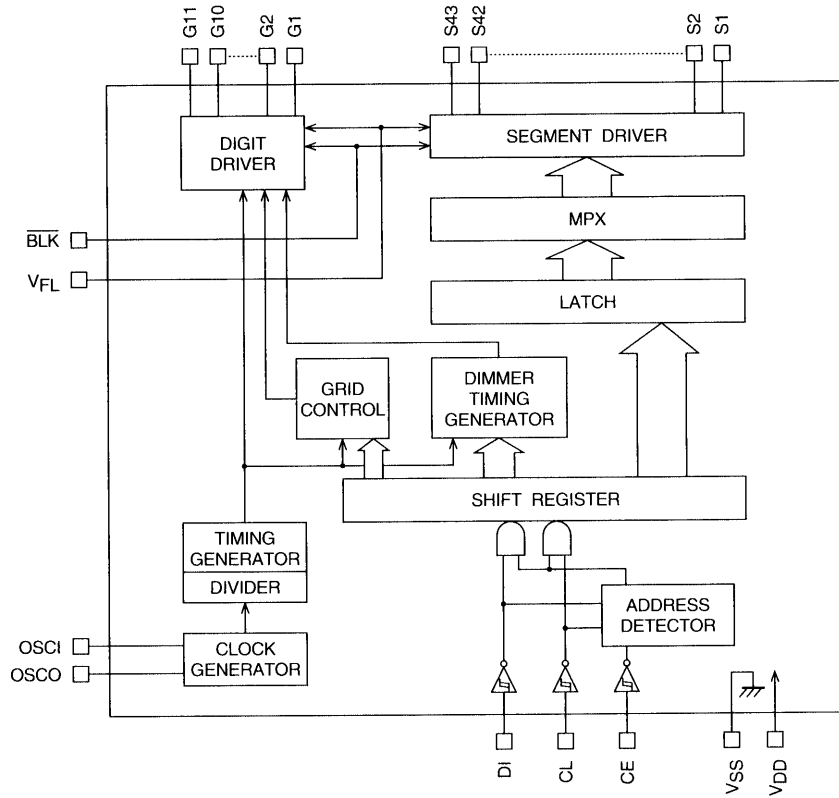

A06735

Pin Functions

Pin	Pin No.	Function	I/O	Handling when unused
V _{FL}	1, 13	Driver block power supply connection. (Both pins must be connected.)	—	—
V _{DD}	60	Logic block power supply connection. Provide a voltage between 4.5 and 5.5 V.	—	—
V _{SS}	57	Power supply connection. Connect to the ground.	—	—
OSC1	59	Oscillator connection. An oscillator circuit is formed by connecting an external resistor and capacitor to these pins.	I	GND
OSCO	58		O	OPEN
BLK	61	Display off control input. BLK = Low (V _{SS}) ... Display off. (S1 to S43 and G1 to G11 at V _{FL} level.) BLK = High (V _{DD}) ... Display on. Note that serial data can be transferred while the display is turned off.	I	GND
CL	63	Serial data transfer inputs. These pins must be connected to the system microcontroller.	I	GND
DI	64	CL: Synchronization clock		
CE	62	DI: Transfer data CE: Chip enable		
G1 to G11	2 to 12	Digit outputs. These pins are P-channel open drain outputs with pull-down resistors.	O	OPEN
S1 to S43	56 to 14	Segment outputs for displaying the display data transferred by serial data input. These pins are P-channel open drain outputs with pull-down resistors.	O	OPEN

LC75725E

Serial Data Transfer Format

1. When CL is stopped at the low level

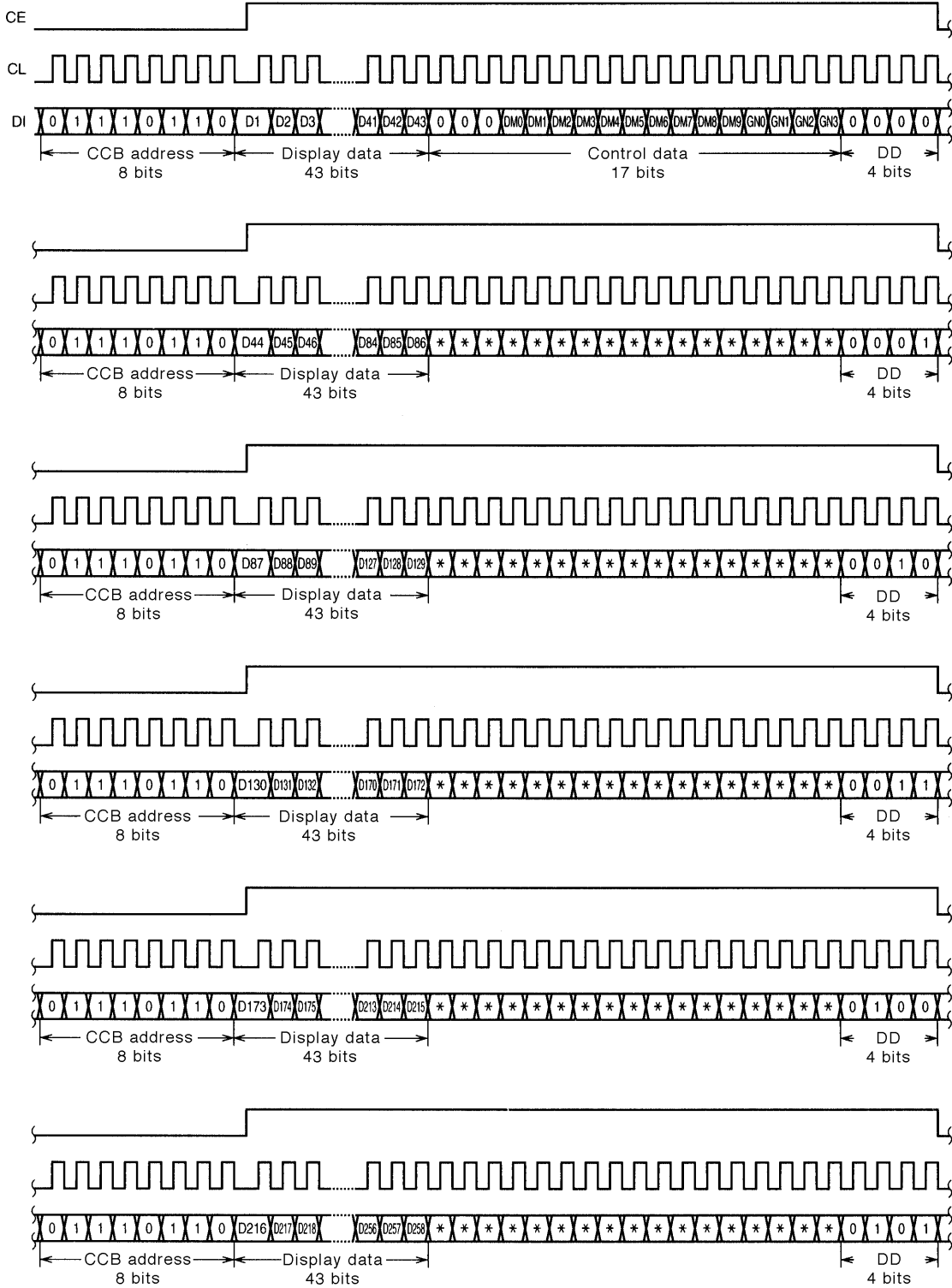

A06736

*: don't care
DD: direction data

LC75725E

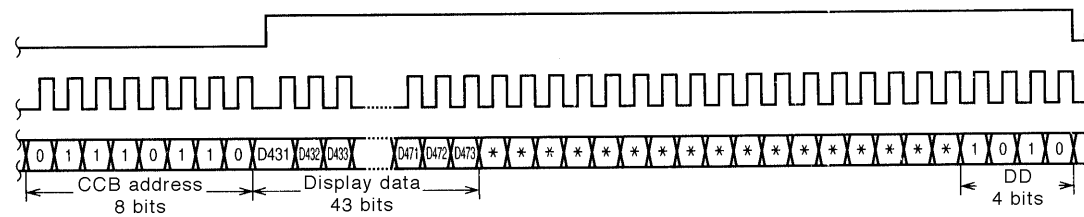
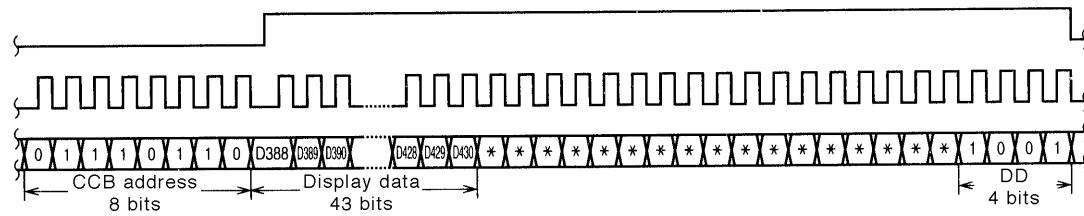
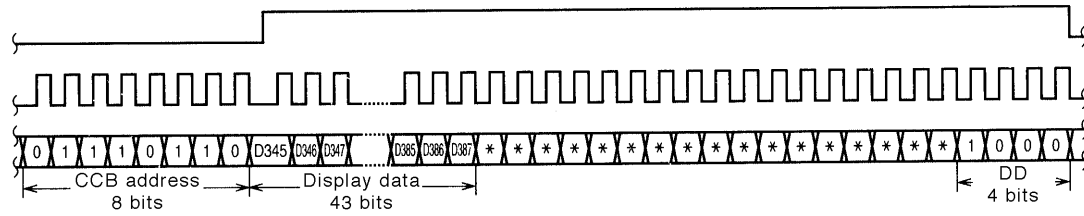
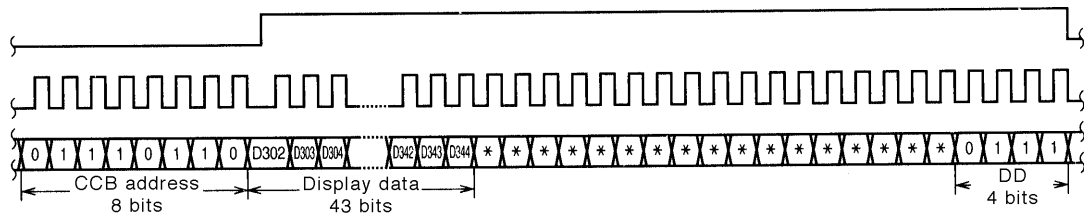
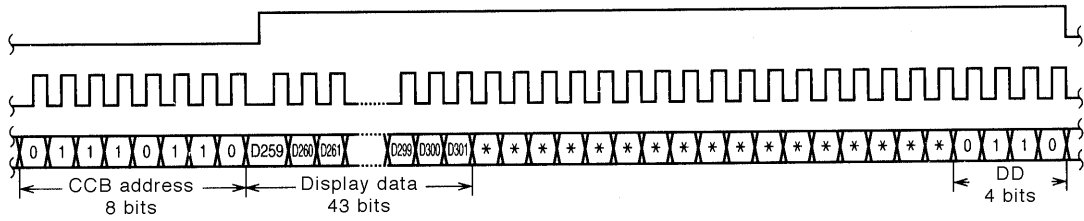

*: don't care
 DD: direction data
 A06737

LC75725E

2. When CL is stopped at the high level

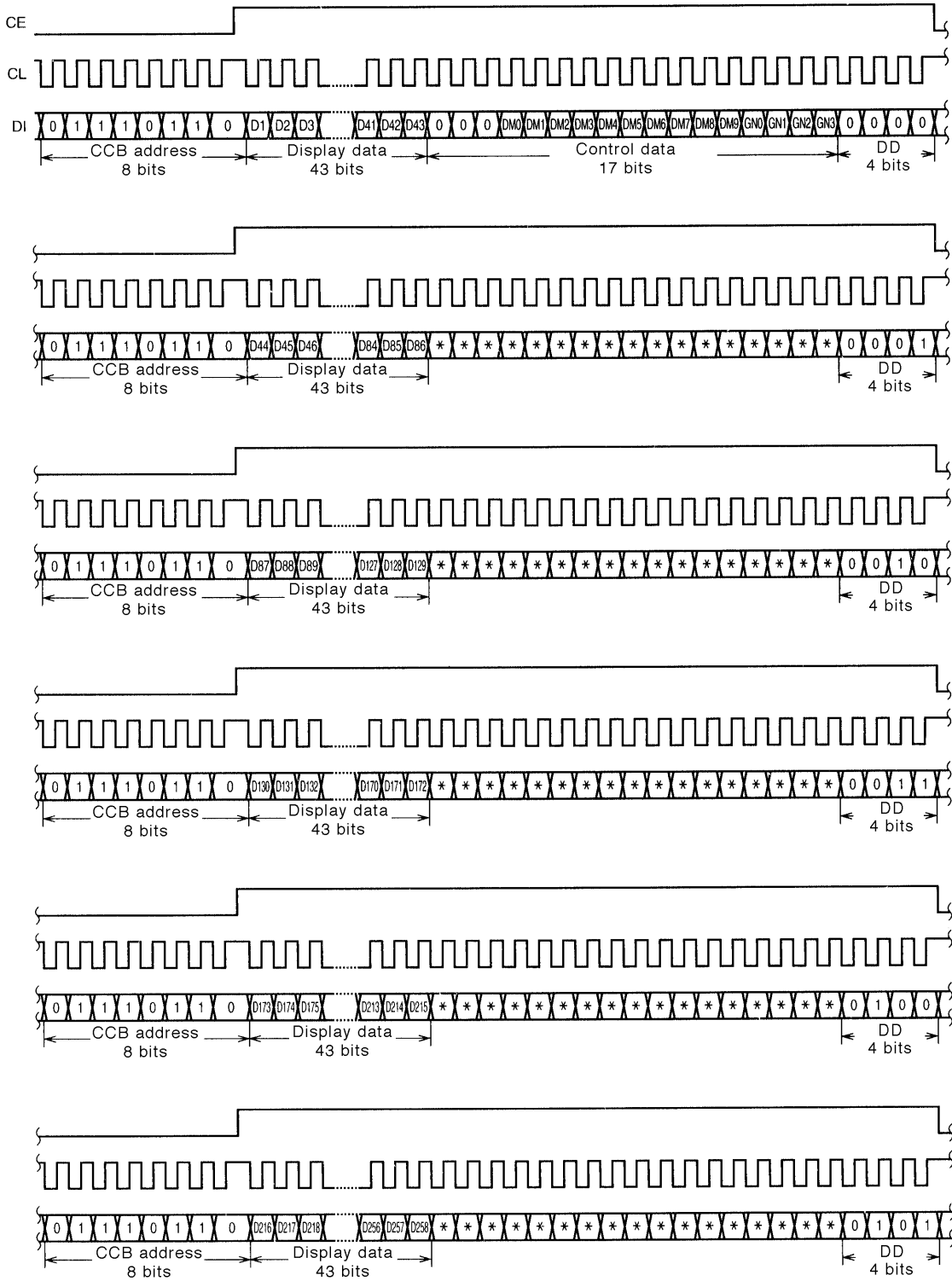

A06738

*: don't care
DD: direction data

LC75725E

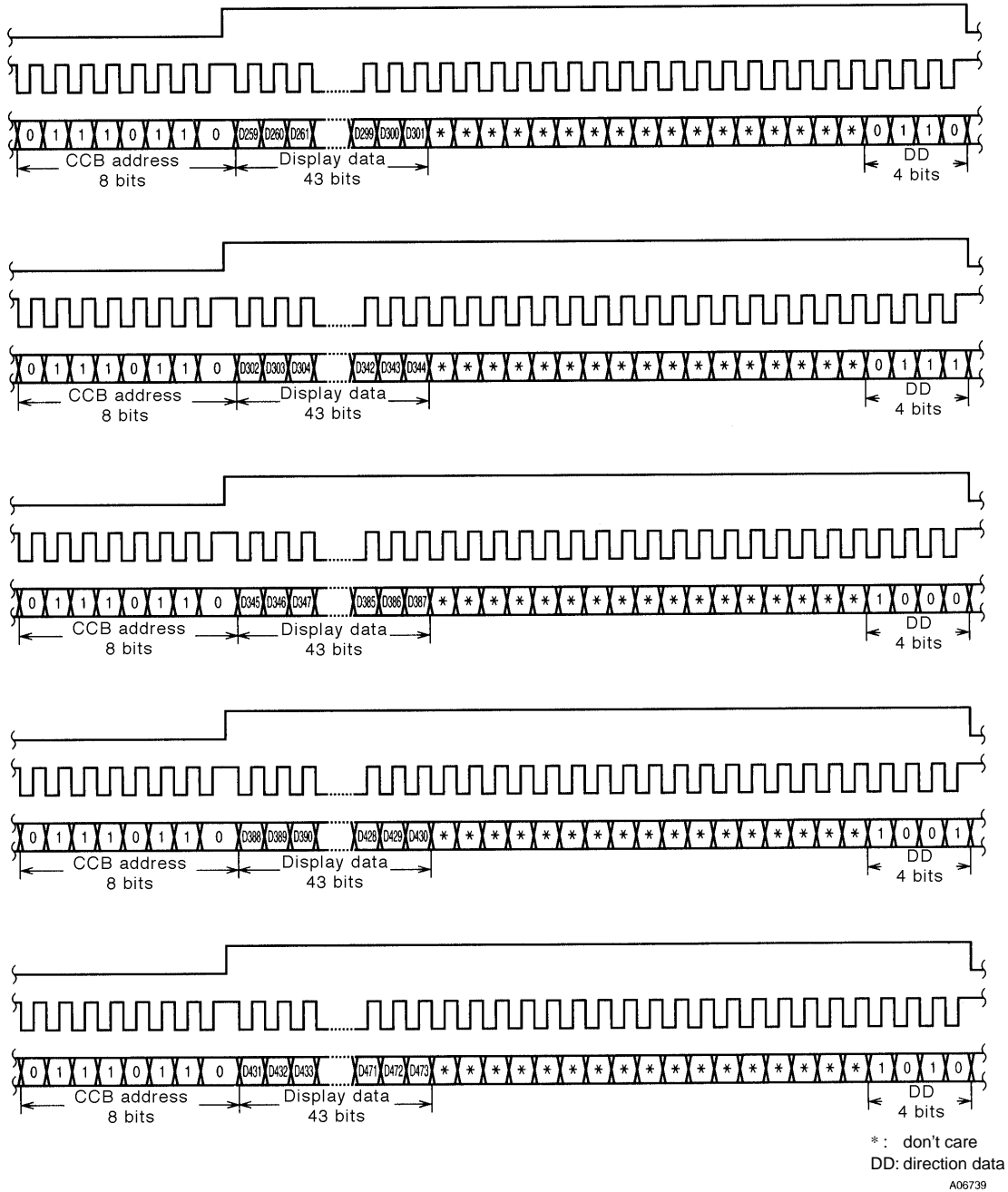

Figure 2

LC75725E

CCB address: Transfer 01110110B as shown in Figure 2.

DM0 to DM9: Dimmer data

This dimmer data controls the duty of the G1 to G11 digit output pins and the S1 to S43 segment output pins. It consists of 10 bits, of which DM0 is the LSB. This dimmer data sets the VFD intensity to one of 993 levels. The following table gives the relationship between the dimmer data and the dimmer level.

DM9	DM8	DM7	DM6	DM5	DM4	DM3	DM2	DM1	DM0	Dimmer level (Ton/Tdig)
0	0	0	0	0	0	0	0	0	0	0/1024
0	0	0	0	0	0	0	0	0	1	1/1024
0	0	0	0	0	0	0	0	1	0	2/1024
										to
1	1	1	1	0	1	1	1	1	0	990/1024
1	1	1	1	0	1	1	1	1	1	991/1024
1	1	1	1	1	0	0	0	0	0	992/1024 (max)
1	1	1	1	1	0	0	0	0	1	992/1024 (max)
										to
1	1	1	1	1	1	1	1	0	1	992/1024 (max)
1	1	1	1	1	1	1	1	1	0	992/1024 (max)
1	1	1	1	1	1	1	1	1	1	Not used

Tdig: Single-digit display time (See Figure 4.)

Ton: Single-digit on time (See Figure 4.)

If distortion of the digit waveforms and segment waveforms by the VFD panel used and the wiring causes spurious glowing of the VFD panel dimly, we recommend setting the dimmer level to a smaller value.

GN0 to GN3: Number of display digits data

This data give the number of digits displayed by the VFD panel, a number between 4 and 11. The following table gives the relationship between this setting and the digit output pins used.

GN3	GN2	GN1	GN0	Digit output pins
0	1	0	0	G1 to G4
0	1	0	1	G1 to G5
0	1	1	0	G1 to G6
0	1	1	1	G1 to G7
1	0	0	0	G1 to G8
1	0	0	1	G1 to G9
1	0	1	0	G1 to G10
1	0	1	1	G1 to G11

For example, if the VFD panel displays six digits using digit output pins G1 to G6, set GN0 to 0, GN1 to 1, GN2 to 1, and GN3 to 0.

D1 to D473: Display data

Dn (n=1 to 473) = 1: Display on

Dn (n=1 to 473) = 0: Display off

D1 to D43 ······ Display data for digit output G1
 D44 to D86 ······ Display data for digit output G2
 D87 to D129 ······ Display data for digit output G3
 D130 to D172 ······ Display data for digit output G4
 D173 to D215 ······ Display data for digit output G5
 D216 to D258 ······ Display data for digit output G6
 D259 to D301 ······ Display data for digit output G7
 D302 to D344 ······ Display data for digit output G8
 D345 to D387 ······ Display data for digit output G9
 D388 to D430 ······ Display data for digit output G10
 D431 to D473 ······ Display data for digit output G11

The number of display data bits transferred depends on the number of digits displayed. For example, if the VFD panel displays six digits, display data bits D1 to D258 are transferred. There is no need to transfer display data bits D259 to D473.

LC75725E

Example of Serial Data Transfer

- Six display digits (1/6 duty)

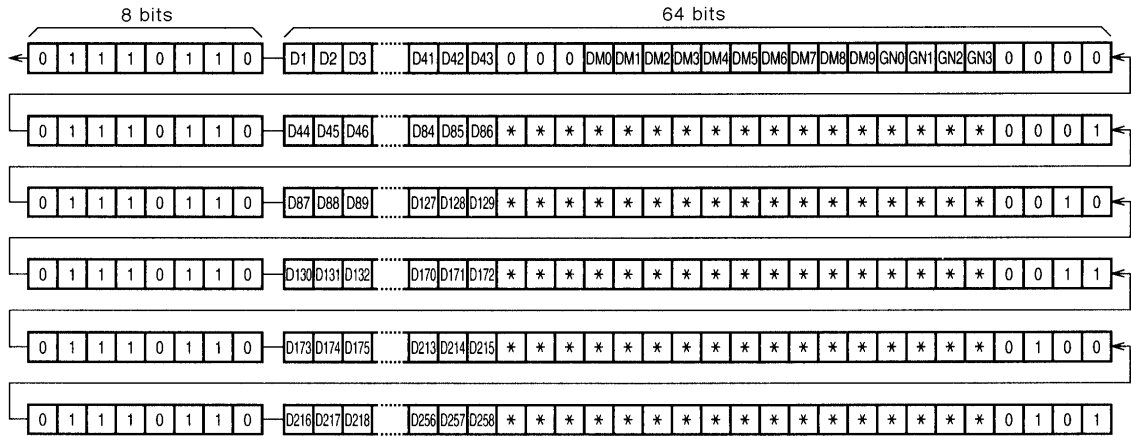

* : don't care

LC75725E

Correspondence between Display Data (D1 to D473) and Segment Output Pins

Segment output pin	G1	G2	G3	G4	G5	G6	G7	G8	G9	G10	G11
S1	D1	D44	D87	D130	D173	D216	D259	D302	D345	D388	D431
S2	D2	D45	D88	D131	D174	D217	D260	D303	D346	D389	D432
S3	D3	D46	D89	D132	D175	D218	D261	D304	D347	D390	D433
S4	D4	D47	D90	D133	D176	D219	D262	D305	D348	D391	D434
S5	D5	D48	D91	D134	D177	D220	D263	D306	D349	D392	D435
S6	D6	D49	D92	D135	D178	D221	D264	D307	D350	D393	D436
S7	D7	D50	D93	D136	D179	D222	D265	D308	D351	D394	D437
S8	D8	D51	D94	D137	D180	D223	D266	D309	D352	D395	D438
S9	D9	D52	D95	D138	D181	D224	D267	D310	D353	D396	D439
S10	D10	D53	D96	D139	D182	D225	D268	D311	D354	D397	D440
S11	D11	D54	D97	D140	D183	D226	D269	D312	D355	D398	D441
S12	D12	D55	D98	D141	D184	D227	D270	D313	D356	D399	D442
S13	D13	D56	D99	D142	D185	D228	D271	D314	D357	D400	D443
S14	D14	D57	D100	D143	D186	D229	D272	D315	D358	D401	D444
S15	D15	D58	D101	D144	D187	D230	D273	D316	D359	D402	D445
S16	D16	D59	D102	D145	D188	D231	D274	D317	D360	D403	D446
S17	D17	D60	D103	D146	D189	D232	D275	D318	D361	D404	D447
S18	D18	D61	D104	D147	D190	D233	D276	D319	D362	D405	D448
S19	D19	D62	D105	D148	D191	D234	D277	D320	D363	D406	D449
S20	D20	D63	D106	D149	D192	D235	D278	D321	D364	D407	D450
S21	D21	D64	D107	D150	D193	D236	D279	D322	D365	D408	D451
S22	D22	D65	D108	D151	D194	D237	D280	D323	D366	D409	D452
S23	D23	D66	D109	D152	D195	D238	D281	D324	D367	D410	D453
S24	D24	D67	D110	D153	D196	D239	D282	D325	D368	D411	D454
S25	D25	D68	D111	D154	D197	D240	D283	D326	D369	D412	D455
S26	D26	D69	D112	D155	D198	D241	D284	D327	D370	D413	D456
S27	D27	D70	D113	D156	D199	D242	D285	D328	D371	D414	D457
S28	D28	D71	D114	D157	D200	D243	D286	D329	D372	D415	D458
S29	D29	D72	D115	D158	D201	D244	D287	D330	D373	D416	D459
S30	D30	D73	D116	D159	D202	D245	D288	D331	D374	D417	D460
S31	D31	D74	D117	D160	D203	D246	D289	D332	D375	D418	D461
S32	D32	D75	D118	D161	D204	D247	D290	D333	D376	D419	D462
S33	D33	D76	D119	D162	D205	D248	D291	D334	D377	D420	D463
S34	D34	D77	D120	D163	D206	D249	D292	D335	D378	D421	D464
S35	D35	D78	D121	D164	D207	D250	D293	D336	D379	D422	D465
S36	D36	D79	D122	D165	D208	D251	D294	D337	D380	D423	D466
S37	D37	D80	D123	D166	D209	D252	D295	D338	D381	D424	D467
S38	D38	D81	D124	D167	D210	D253	D296	D339	D382	D425	D468
S39	D39	D82	D125	D168	D211	D254	D297	D340	D383	D426	D469
S40	D40	D83	D126	D169	D212	D255	D298	D341	D384	D427	D470
S41	D41	D84	D127	D170	D213	D256	D299	D342	D385	D428	D471
S42	D42	D85	D128	D171	D214	D257	D300	D343	D386	D429	D472
S43	D43	D86	D129	D172	D215	D258	D301	D344	D387	D430	D473

$\overline{\text{BLK}}$ and the Display Control

Since the LSI internal data (D1 to D473 and the control data) is undefined when power is first applied, the display is off (S1 to S43 and G1 to G11 pins = VFL level) by setting the $\overline{\text{BLK}}$ pin low at the same time as power is applied. Then, meaningless display at power on can be prevented by transferring the necessary serial data from the controller while the display is off and set the $\overline{\text{BLK}}$ pin high after the transfer completes. (See Figure 3.)

Power Supply Sequence

The following sequences must be observed when the power is turned on and off. (See Figure 3.)

- Power on : Logic block power supply (V_{DD}) on → Driver block power supply (V_{FL}) on
- Power off : Driver block power supply (V_{FL}) off → Logic block power supply (V_{DD}) off

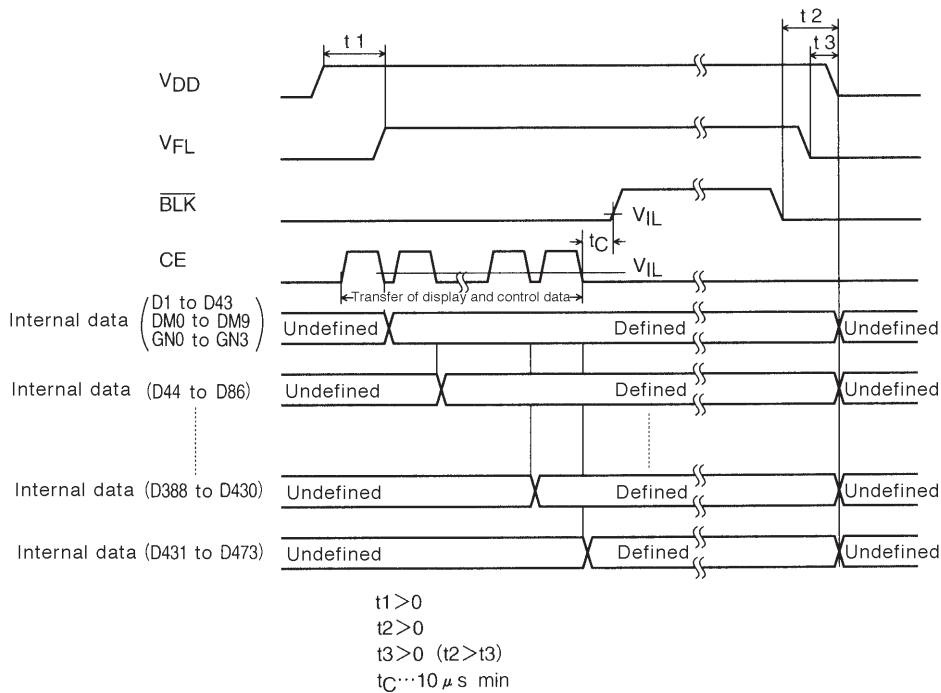
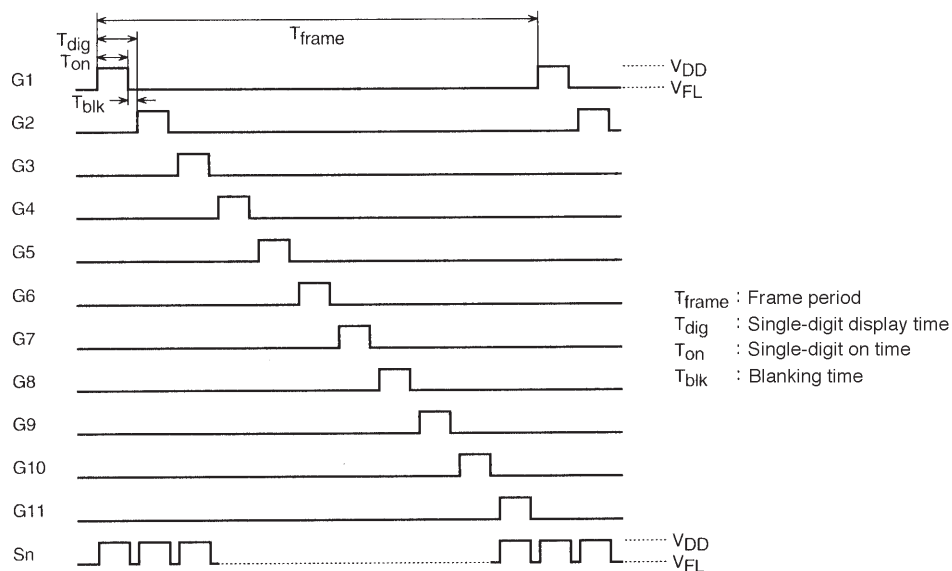

Figure 3

LC75725E

Digit Timing Chart (11 display digits)

T_{frame} , the frame period, is $T_{dig} \times N$, where N is the number of display digits. T_{dig} , the single-digit display time, is $2048/f_{osc}$, where f_{osc} is the oscillator frequency. When the number of display digits is 11 and the oscillator frequency, f_{osc} , is 3.7 MHz, T_{dig} will be about 554 μs and T_{frame} will be about 6.09 ms.



A06742

Figure 4

Sample Application Circuit

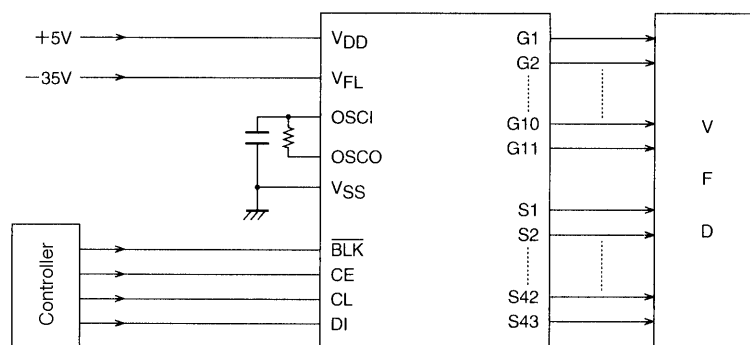

A06743

- No products described or contained herein are intended for use in surgical implants, life-support systems, aerospace equipment, nuclear power control systems, vehicles, disaster/crime-prevention equipment and the like, the failure of which may directly or indirectly cause injury, death or property loss.
- Anyone purchasing any products described or contained herein for an above-mentioned use shall:
 - ① Accept full responsibility and indemnify and defend SANYO ELECTRIC CO., LTD., its affiliates, subsidiaries and distributors and all their officers and employees, jointly and severally, against any and all claims and litigation and all damages, cost and expenses associated with such use:
 - ② Not impose any responsibility for any fault or negligence which may be cited in any such claim or litigation on SANYO ELECTRIC CO., LTD., its affiliates, subsidiaries and distributors or any of their officers and employees jointly or severally.
- Information (including circuit diagrams and circuit parameters) herein is for example only; it is not guaranteed for volume production. SANYO believes information herein is accurate and reliable, but no guarantees are made or implied regarding its use or any infringements of intellectual property rights or other rights of third parties.

This catalog provides information as of March, 1998. Specifications and information herein are subject to change without notice.