

Ordering number : EN4929A

CMOS LSI



LC75366, 75366M

Two-Channel Electronic Volume Control



Overview

The LC75366 (DIP20) and the LC75366M (MFP20) are electronic volume controls that can be controlled by serial input data and provide volume, balance and loudness functions.

Features

- Silicon gate CMOS process for low switching noise

Functions

- Volume: 0 dB to -68 dB (in 2 dB steps) and -∞; 36 positions.
A balance function can be implemented by controlling the left and right channel volume settings independently.
- Loudness: Taps are provided at the -20 dB positions in the 10 dB step resistor ladder used by the volume control function. A loudness function can be implemented by attaching external RC circuits at these tap points.
- An address selection pin (the S pin) allows two LC75366 chips to be used on the same bus.
- Serial data input: Supports CCB* format communication with the system controller.

- CCB is a trademark of SANYO ELECTRIC CO., LTD.
- CCB is SANYO's original bus format and all the bus addresses are controlled by SANYO.

Specifications

Absolute Maximum Ratings at Ta = 25°C, VSS = 0 V

Parameter	Symbol	Conditions	Ratings	Unit
Maximum supply voltage	V _{DD} max	V _{DD}	12	V
Maximum input voltage	V _{IN} max1	CL, DI, CE, S	V _{SS} - 0.3 to V _{DD} + 0.3	V
	V _{IN} max2	L10dBIN, L2dBIN, R10dBIN, R2dBIN	V _{SS} - 0.3 to V _{DD} + 0.3	V
Allowable power dissipation	Pd max	Ta ≤ 85°C	140	mW
Operating temperature	Topr		-40 to +85	°C
Storage temperature	Tstg		-50 to +125	°C

Package Dimensions

unit: mm

3021B-DIP20

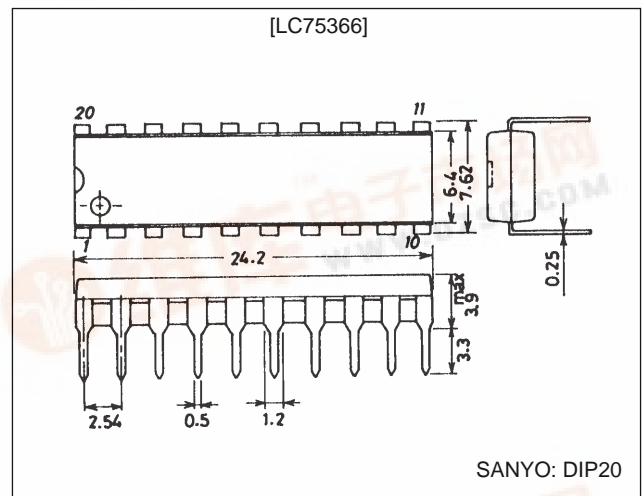

unit: mm

3036B-MFP20

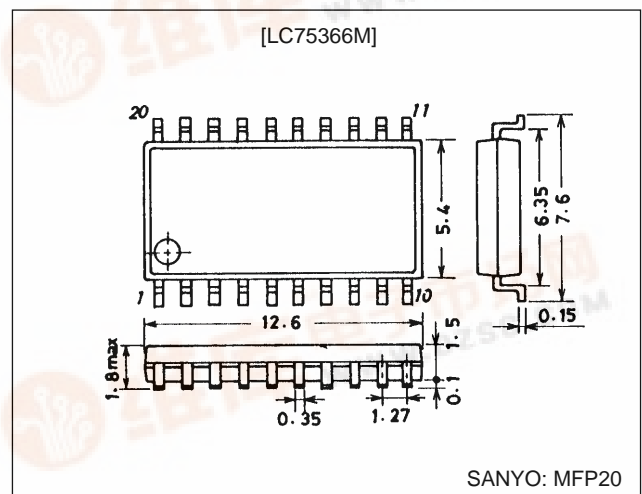

LC75366, 75366M

Allowable Operating Ranges at $T_a = 25^\circ\text{C}$, $V_{SS} = 0\text{ V}$

Parameter	Symbol	Conditions	Ratings	Unit
Supply voltage	V_{DD}	V_{DD}	4.0 to 11.0	V
Input high level voltage	$V_{IH}(1)$	CL, DI, CE	$0.3 V_{DD} + 1$ to V_{DD}	V
	$V_{IH}(2)$	S	$0.8 V_{DD}$ to V_{DD}	V
Input low level voltage	$V_{IL}(1)$	CL, DI, CE	V_{SS} to $0.2 V_{DD}$	V
	$V_{IL}(2)$	S	V_{SS} to $0.2 V_{DD}$	V
Input voltage amplitude	V_{IN}	L10dBIN, L2dBIN, R10dBIN, R2dBIN	V_{SS} to V_{DD}	Vp-p
Input pulse width	$t_{\phi W}$	CL	1 or longer	μs
Setup time	$t_{\text{set up}}$	CL, DI, CE	1 or longer	μs
Hold time	t_{hold}	CL, DI, CE	1 or longer	μs
Operating frequency	fop	CL	Up to 500	kHz

Electrical Characteristics at $T_a = 25^\circ\text{C}$, $V_{SS} = 0\text{ V}$

Parameter	Symbol	Conditions	min	typ	max	Unit
Total harmonic distortion	THD (1)	$V_{IN} = 1\text{ V}_{\text{rms}}$, $f = 1\text{ kHz}$, all settings flat overall, $V_{DD} = 9\text{ V}$		0.006		%
	THD (2)	$V_{IN} = 1\text{ V}_{\text{rms}}$, $f = 20\text{ kHz}$, all settings flat overall, $V_{DD} = 9\text{ V}$		0.015		%
Crosstalk	CT	$V_{IN} = 1\text{ V}_{\text{rms}}$, $f = 20\text{ kHz}$, all settings flat overall, $R_g = 1\text{ k}\Omega$		85		dB
Output at maximum attenuation	$V_{O\text{ min}}$	$V_{IN} = 1\text{ V}_{\text{rms}}$, $f = 20\text{ kHz}$, volume setting: $-\infty$, with a $470\text{ }\mu\text{F}$ capacitor between L/R Vref and V_{SS}		-80		dB
Total resistance	$R_{VOL}(1)$	10 dB steps	28.2	47	65.8	$\text{k}\Omega$
	$R_{VOL}(2)$	2 dB steps	12	20	28	$\text{k}\Omega$
Output off leakage current	I_{off}	L10dBIN, R10dBIN, LCT1, L2dBIN, R2dBIN, RCT1, L10dBOUT, R10dBOUT, LCT2, L2dBOUT, R2dBOUT, RCT2, LVref, RVref	-10		+10	μA
Input high level current	I_{IH}	$V_I = V_{DD}$ (CL, CE and DI pins)			10	μA
Input low level current	I_{IL}	$V_I = V_{SS}$ (CL, CE and DI pins)	-10			μA
Output noise voltage	V_N	All settings flat overall (IHF-A), $V_{DD} = 9\text{ V}$, $R_g = 1\text{ k}\Omega$		2	10	μV
Current drain	I_{DD}	$V_{DD} - V_{SS} = 11\text{ V}$			1	mA
Analog switch on resistance (Design target value)	R_{ON}	CT1	180	300	420	Ω
		For use between CT2 and Vref	90	150	210	Ω
		0 dB, $-\infty$	0.6	1.0	1.4	$\text{k}\Omega$
		Other than the above	6.0	10.0	14.0	$\text{k}\Omega$

Pin Assignment

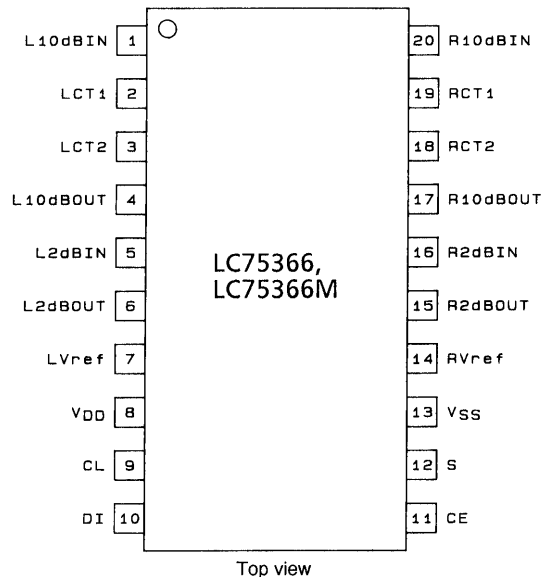

LC75366, 75366M

Equivalent Circuit Block Diagram

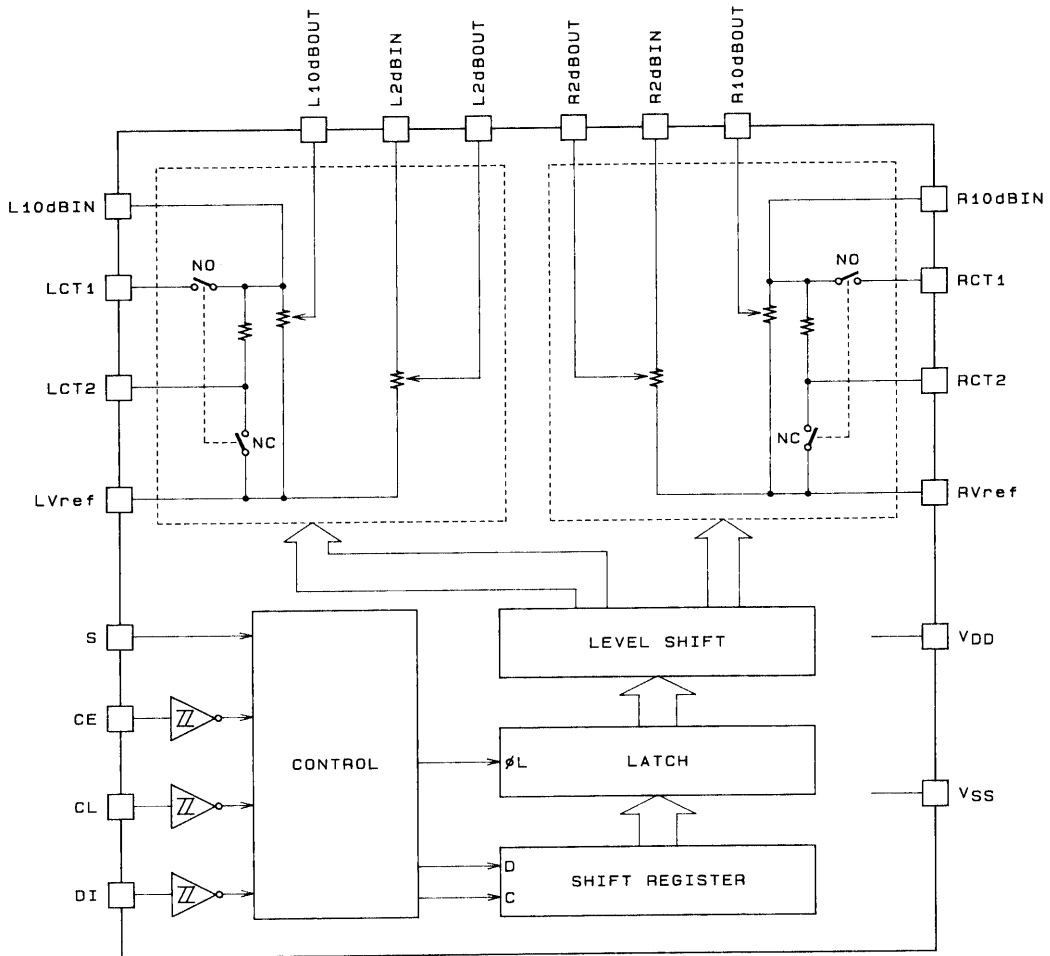

A02831

Test Circuits

1. Total harmonic distortion

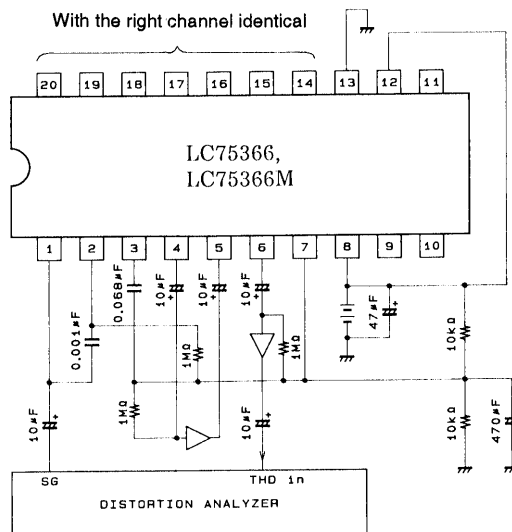

A02832

LC75366, 75366M

2. Output noise voltage

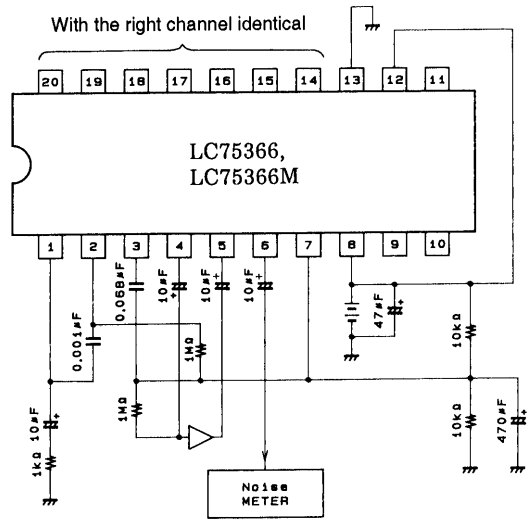

3. Crosstalk

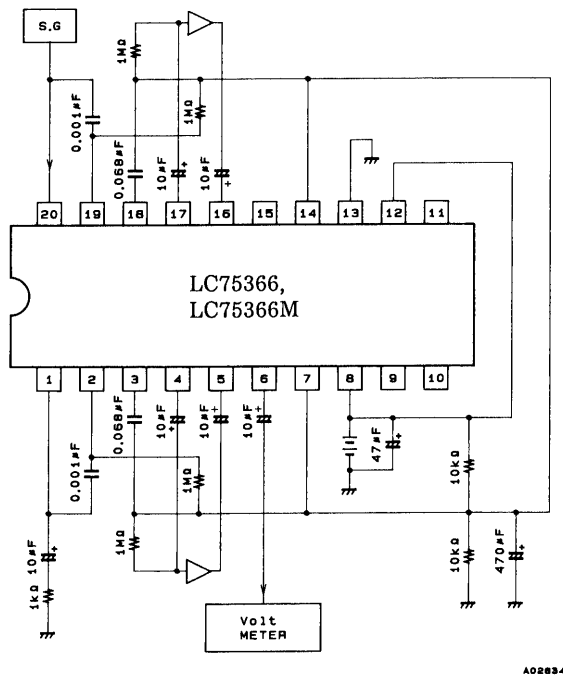

LC75366, 75366M

Volume Block Equivalent Circuit

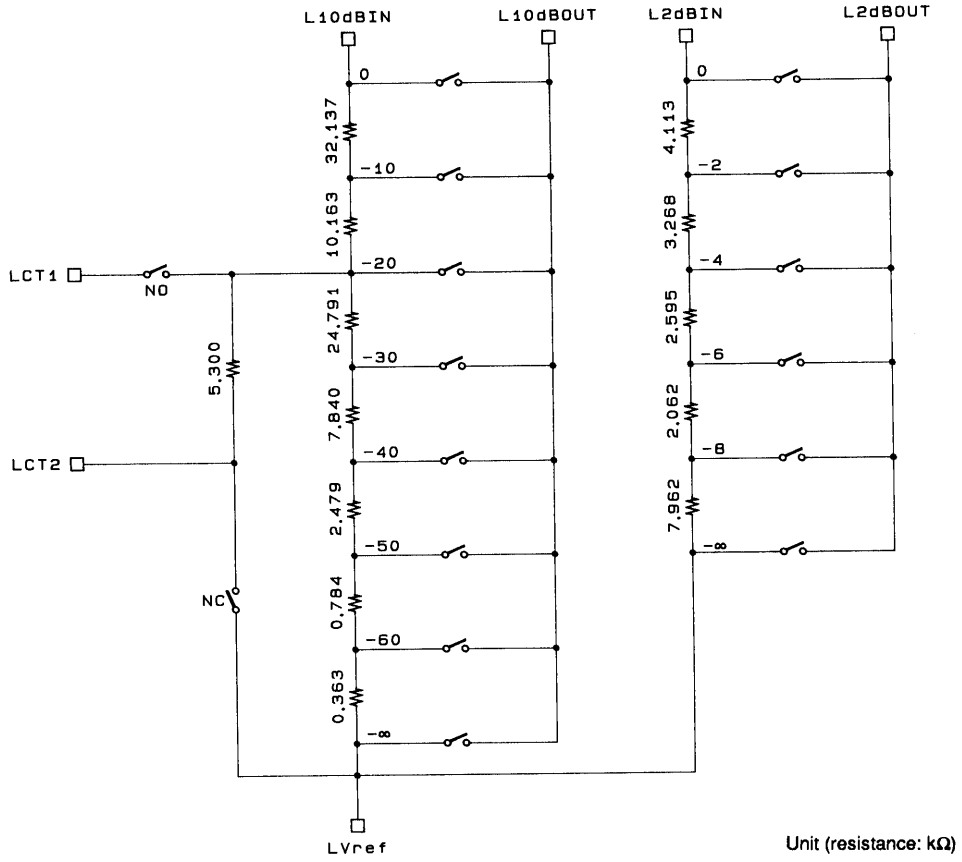

The right channel is identical.

A02835

LC75366, 75366M

Pin Functions

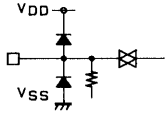
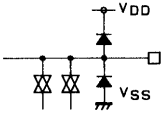
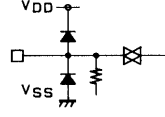
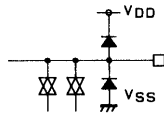
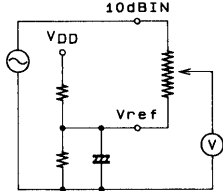
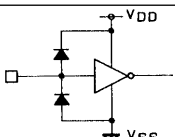
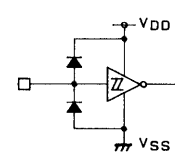
Pin No.	Symbol	Function	Note
1	L10dBIN	Input pins for the 10 dB step attenuator. Must be driven from a low impedance.	 <p style="text-align: right;">A02835</p>
20	R10dBIN		
2	LCT1	Loudness connections. Connect a high band compensation capacitor between CT1 and 10dBIN and connect a low band compensation capacitor between CT2 and Vref.	
3	LCT2		
19	RCT1		
18	RCT2		
4	L10dBOUT	Output pins for the 10 dB step attenuator. These outputs must be received by a load of about 1 MΩ.	 <p style="text-align: right;">A02837</p>
17	R10dBOUT		
5	L2dBIN	Input pins for the 2 dB step attenuator. Must be driven from a low impedance.	 <p style="text-align: right;">A02835</p>
16	R2dBIN		
6	L2dBOUT	Output pins for the 2 dB step attenuator. These outputs must be received by a load of about 1 MΩ.	 <p style="text-align: right;">A02837</p>
15	R2dBOUT		
7	LVref	Volume circuit common pins. The impedance of the pattern connected to these pins should be kept as low as possible. Since the capacitors between Vref and VSS form the residual resistance components when the volume is cut, adequate care must be taken in determining the value of these capacitors.	 <p style="text-align: right;">A02838</p>
14	RVref		
12	S	Pin that selects the address code in the data format. Data will be accepted for an address code of 88 when this pin is tied to V _{DD} , and for an address code of 89 when tied to V _{SS} .	 <p style="text-align: right;">A02839</p>
9	CL	Serial data and clock inputs for control	
10	DI		
11	CE	Chip enable. The internally latched data is written and the analog switches operate when this pin goes from high to low. Data transfer is enabled when this pin is at the high level.	 <p style="text-align: right;">A02840</p>
8	V _{DD}	These pins must be connected to the power supply.	
13	V _{SS}		

LC75366, 75366M

Control System Timing and Data Format

Apply the stipulated serial data to the CE, CL and DI pins to control the LC75366 and LC75366M. The data consists of 20 bits, of which 8 bits are the address and 12 bits are control data.

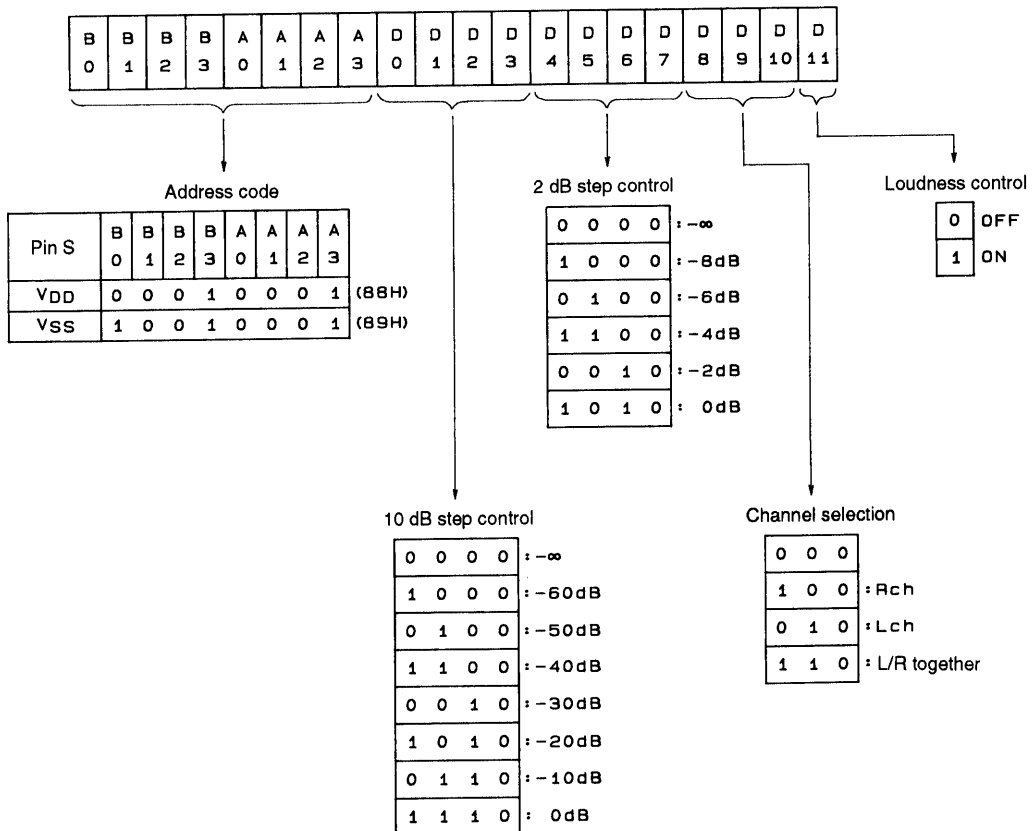
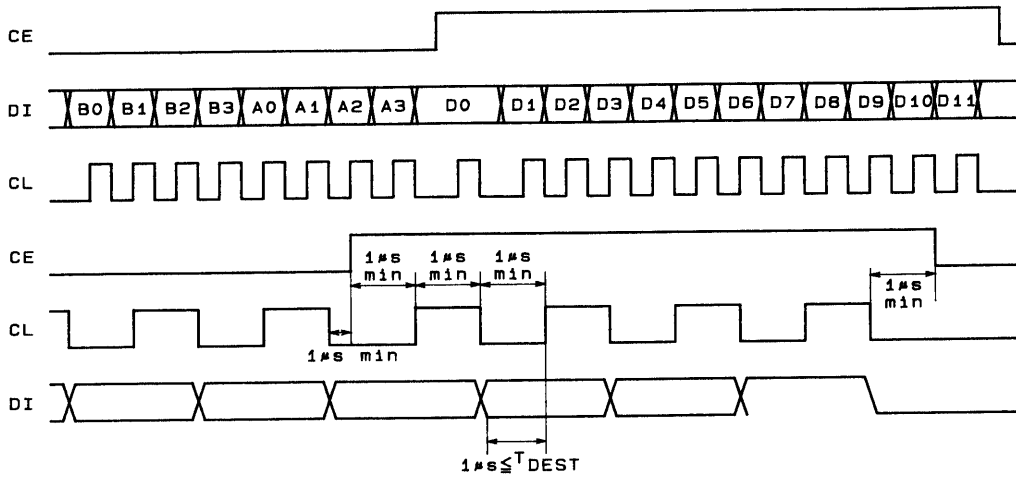

LC75366, 75366M

Sample Application Circuit

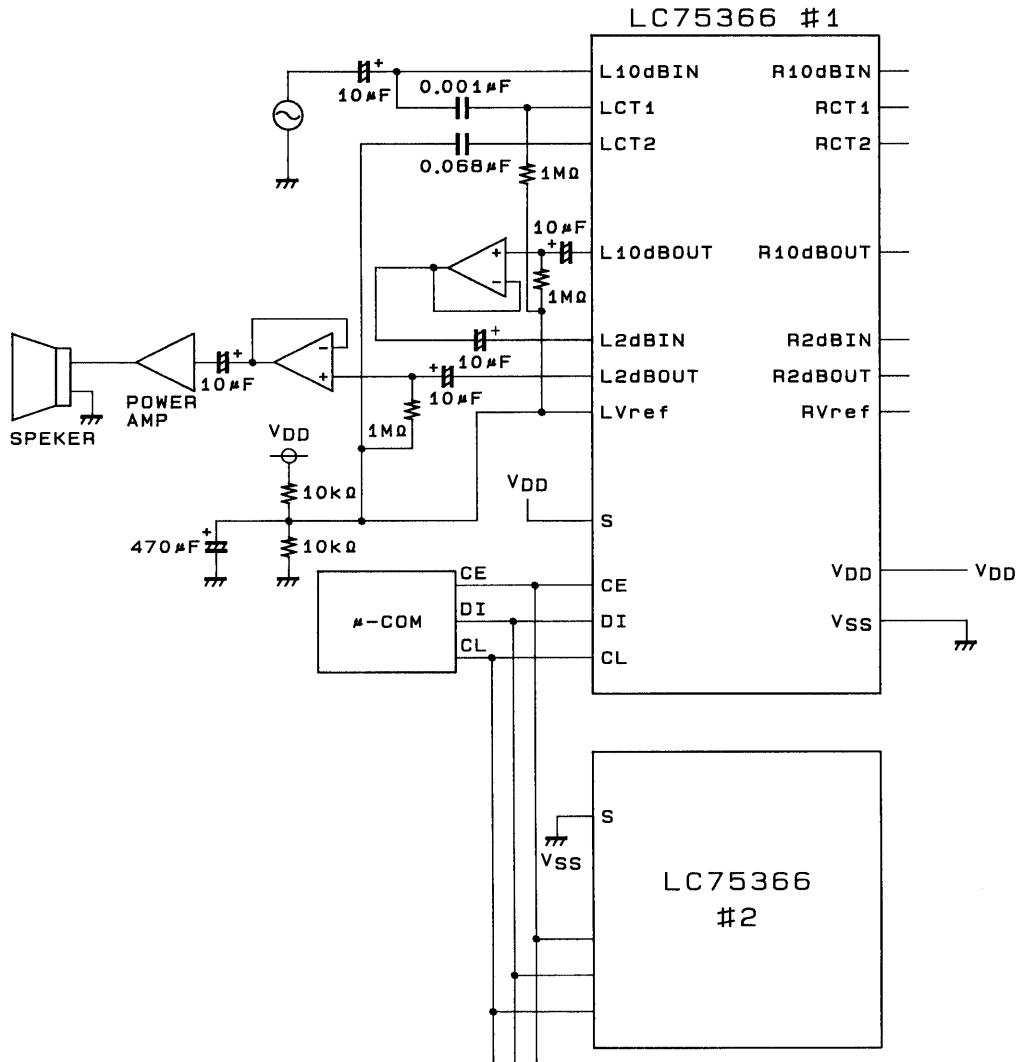

Volume step characteristics

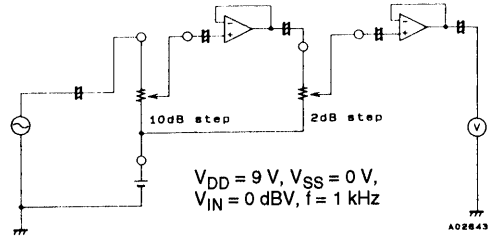
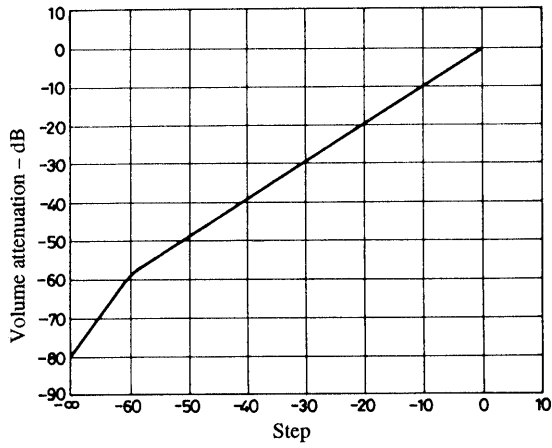

THD – Supply voltage characteristics (1)

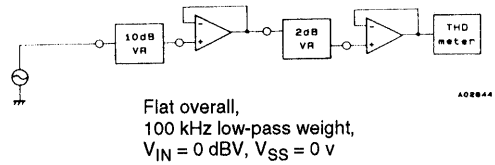
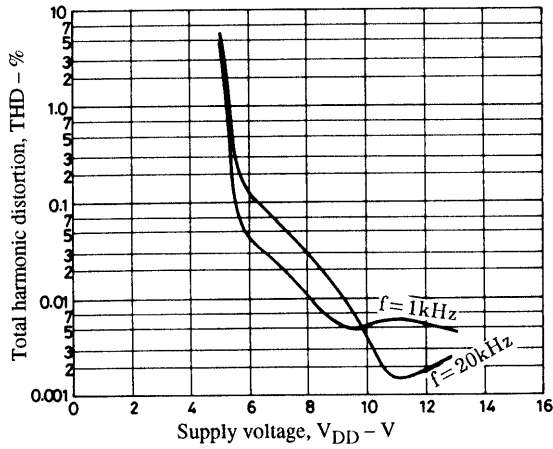

THD – Supply voltage characteristics (2)

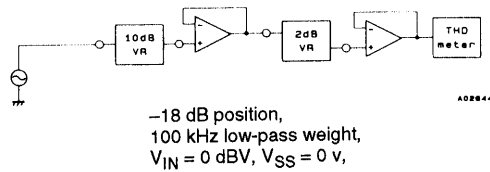
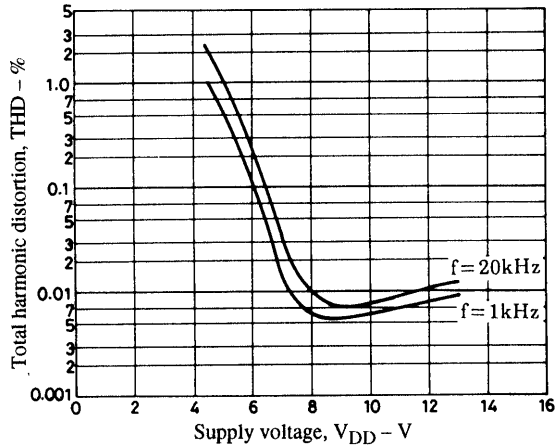

THD – Frequency characteristics

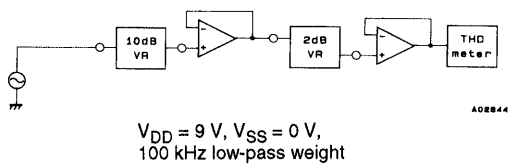
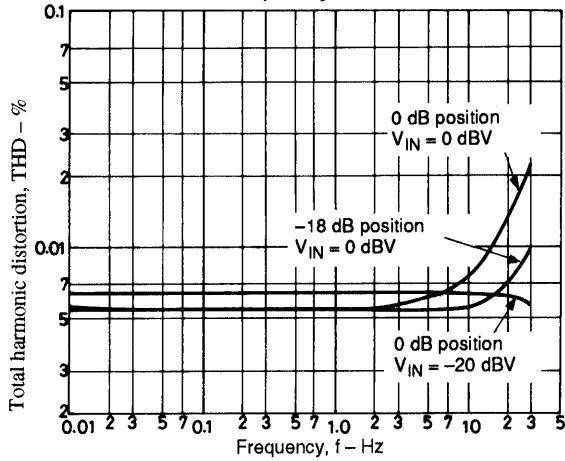

LC75366, 75366M

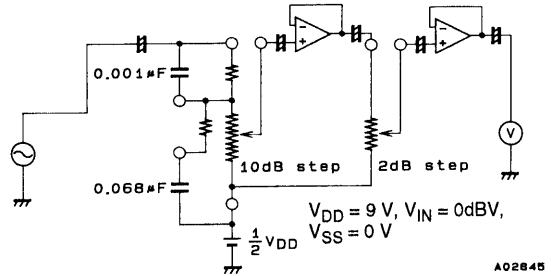
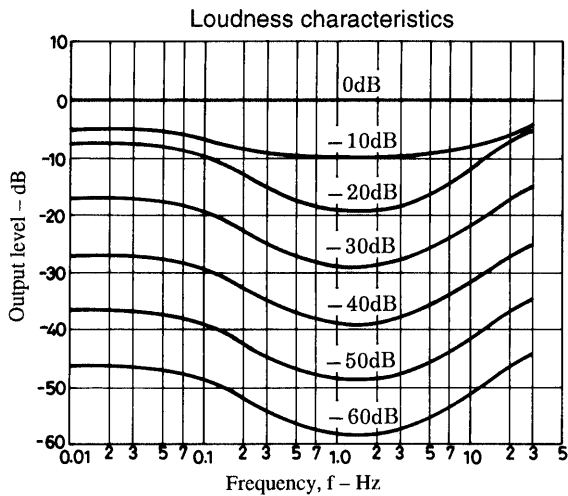
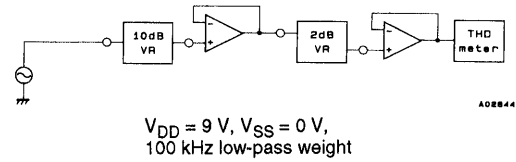
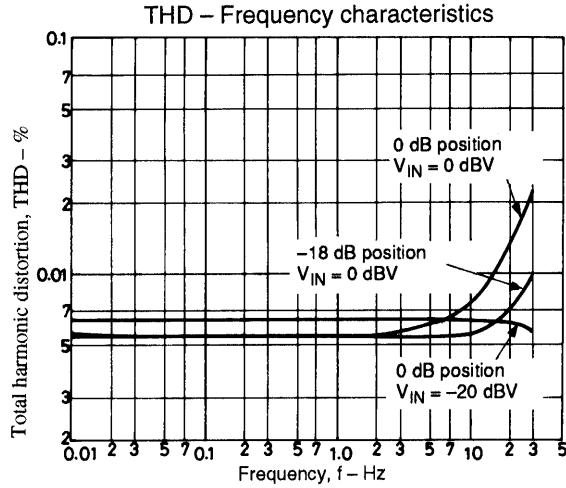

Loudness Function External Circuit Constant Calculation Example

First, refer to the LC75366 and LC75366M 10 dB step internal equivalent circuit shown on page 5. Figure 1 below shows this circuit simplified with the external components used for the loudness function connected for this calculation. The sample calculation below uses this diagram to acquire a 5 dB boost at f = 100 Hz.

(f = 100 Hz, 5 dB boost)

Let R and C in Figure 1 be:

R1 = R2 = 10 kΩ

R3 = 1 kΩ

C1 = Z1, C2 = Z2

Then:

$$V_{OUT} = \frac{\frac{R_2 (R_3 + Z_2)}{R_2 + R_3 + Z_2}}{\frac{R_1 \cdot Z_1}{R_1 + Z_1} + \frac{R_2 (R_3 + Z_2)}{R_2 + R_3 + Z_2}} = -20 \text{ dB}$$

(at = 1 kHz)

$$V_{OUT} = \frac{\frac{R_2 (R_3 + 10 \cdot Z_2)}{R_2 + R_3 + 10 \cdot Z_2}}{\frac{R_1 \cdot 10 \cdot Z_1}{R_1 + 10 \cdot Z_1} + \frac{R_2 (R_3 + 10 \cdot Z_2)}{R_2 + R_3 + 10 \cdot Z_2}} = -15 \text{ dB}$$

(at = 100 Hz)

Solving the above equations gives:

Z1 ≠ 178.3 kΩ and Z2 = 176 Ω

LC75366, 75366M

Therefore, under such conditions where $f = 1$ kHz, specifications may be satisfied if C (capacitor) having these impedances is supplied externally.

The result is that $C1 = 893$ pF and $C2 = 0.9$ μ F.

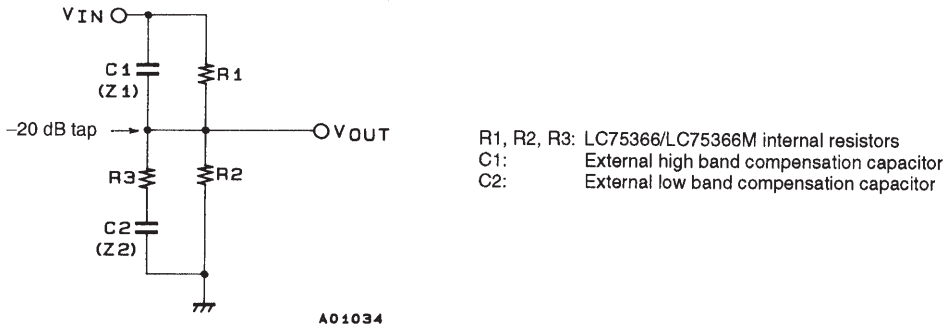

Figure 1

Usage Notes

1. The states of the internal analog switches will be indeterminate when power is first applied. Muting should be applied externally until control data has been transferred and stored.
2. The signal lines for the CL, DI and CE pins should either be covered by the pattern ground or be formed from shielded cable to prevent the high-frequency digital signals transmitted over these lines from entering the analog system.

- No products described or contained herein are intended for use in surgical implants, life-support systems, aerospace equipment, nuclear power control systems, vehicles, disaster/crime-prevention equipment and the like, the failure of which may directly or indirectly cause injury, death or property loss.
- Anyone purchasing any products described or contained herein for an above-mentioned use shall:
 - ① Accept full responsibility and indemnify and defend SANYO ELECTRIC CO., LTD., its affiliates, subsidiaries and distributors and all their officers and employees, jointly and severally, against any and all claims and litigation and all damages, cost and expenses associated with such use:
 - ② Not impose any responsibility for any fault or negligence which may be cited in any such claim or litigation on SANYO ELECTRIC CO., LTD., its affiliates, subsidiaries and distributors or any of their officers and employees jointly or severally.
- Information (including circuit diagrams and circuit parameters) herein is for example only; it is not guaranteed for volume production. SANYO believes information herein is accurate and reliable, but no guarantees are made or implied regarding its use or any infringements of intellectual property rights or other rights of third parties.

This catalog provides information as of November, 1997. Specifications and information herein are subject to change without notice.