

Thick Film Hybrid IC

SANYO

No. 4419

STK733C**24 V Output MOS Chopper Regulator****Overview**

The STK733C is a 24 V dedicated, single-output regulator equipped applied to a switching device and is equipped with a step-down chopper which employs a power metal oxide semiconductor (MOS) field effect transistor (FET).

The STK733C is designed to provide to cover current ranges supporting the difficult 2A class and greater using 3-pin regulator dropper system, to support chopper regulator used to date which apply bipolar transistors, and to further advance high efficiency by applying a MOS FET. In addition to these, the STK733C supports compact packaging and improved performance by incorporating dedicated switching control IC applications. Support for a single power source input is provided with the development of an independent MOS driver circuit. The STK733C is basically designed to support a wide range of power supply circuits applications while functioning as a secondary regulator for switching between power supplies and an output regulator located after the AC transformation rectifier.

Applications

- Power supplies for printers and other office automation (OA) devices.
- Power supplies for robots and other factory automation (FA) devices.
- Power supplies for video cassette recorders (VCR) and other devices used by the general public.
- Secondary regulator for switching power supplies.

Features

- Incorporates Sanyo's original Insulated Metal Substrate Technology (IMST).
- High-efficiency by using MOS FET.
- Supports use of single power source for input system streamlining by developing an independent N MOS FET driver circuit which eliminates the need for an auxiliary power source for drive applications.
- Built-in L-type over-current protect function.
- Simplified ground (GND) line processing even with multi-output power supply configuration employing over-current detection resistor positive line settings.
- Provides high stability for switching frequencies to support other oscillation forms.
- Built-in cut-off function supports ON/OFF control of output using external signal.
- Switching operation frequency set at 85 kHz and supports multi-output configuration with STK730 (5 V output 125 kHz).

Package Dimensions

unit : mm

4137

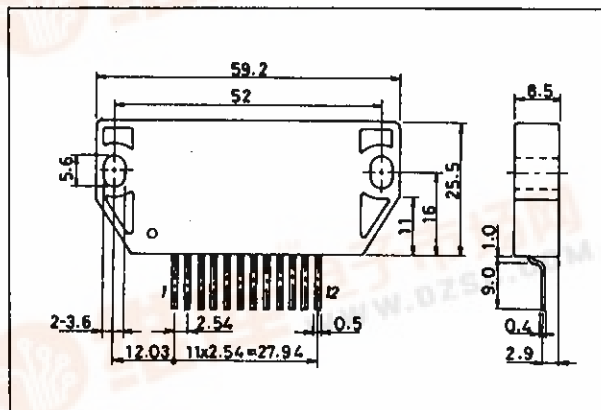

STK733C

Specifications

Maximum Ratings at Ta = 25°C

			unit
Maximum DC input voltage	Vin (DC) max	60	V
Maximum output current	Io max	5/10pk	A
Thermal resistance	θj-c	3.5	°C/W
Junction temperature	Tj max	150	°C
Operating substrate temperature	Tc max	105	°C
Storage temperature	Tstg	-30 to +105	°C

Operating Characteristics at Ta=25°C, see specified Test Circuit.

			min	typ	max	unit
Output voltage	Vo	Vin (DC) = 35V, Io = 1A	23.6	24.0	24.4	V
Ripple voltage	Vrp	Vin (DC) = 35V, Io = 1A			20	mVrms
Input regulation	Reg-IN	Vin (DC) = 28 to 40V, Io = 1A			20	mV/V
Load regulation	Reg-L	Vin (DC) = 35V, Io = 0.5 to 5A			40	mV/A
Over-current protection starting current	I _{OC} P	Vin (DC) = 35V	10			A
Efficiency	η	Vin (DC) = 35V, Io = 2.5A		93		%
Operating frequency	f	Vin (DC) = 35V, Io = 1A		85		kHz
Output voltage temperature coefficient	T _{CV} O	Vin (DC) = 35V, Io = 1A		0.01		%/°C
Output cut off function	Voff	Output ON	3		20	V
		Output OFF	0		0.8	V

Definition of Peak Current

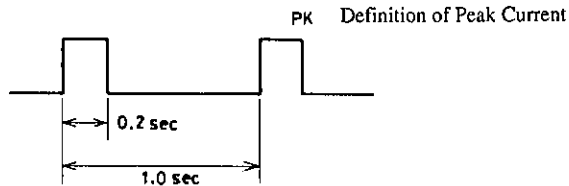

Block Diagram

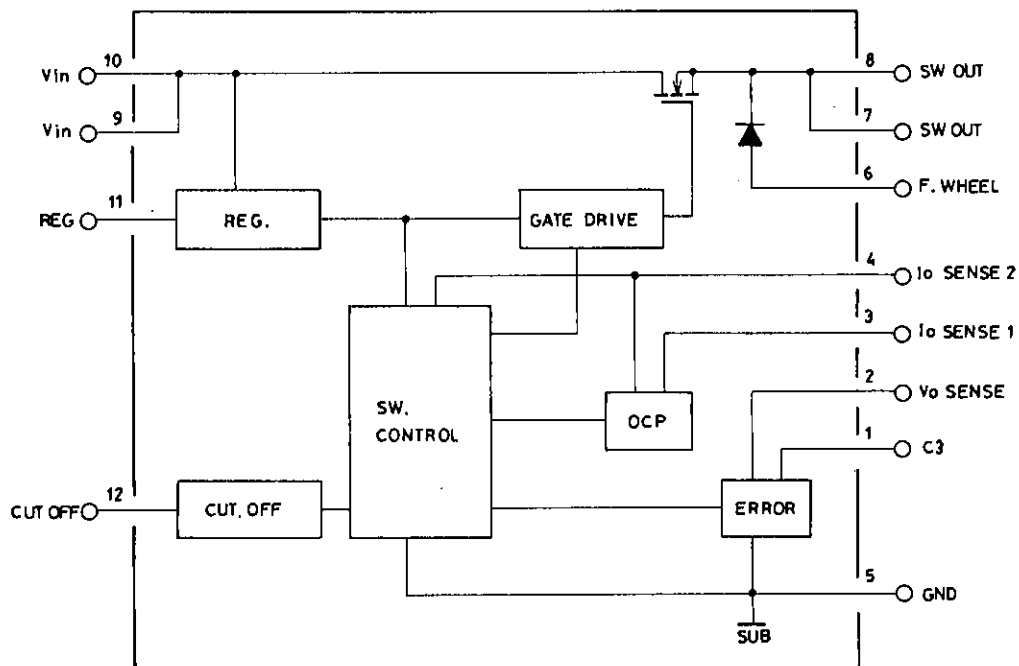

STK733C

Test Circuit

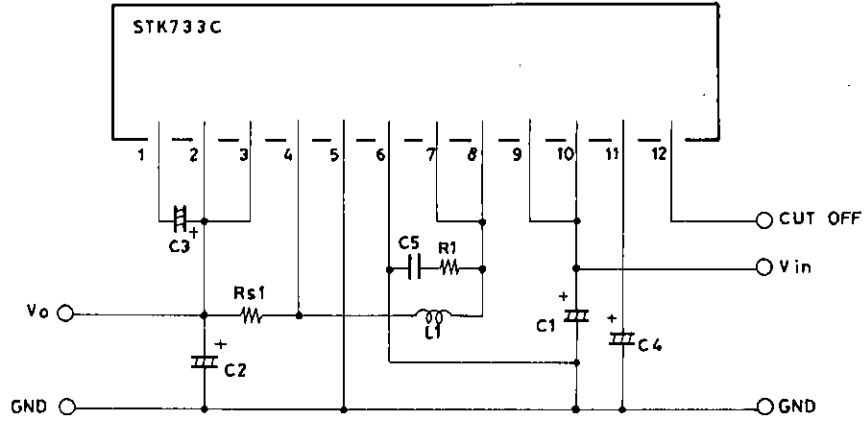

C1	220 μ F / 63V	L1	200 μ H (HP-054/TOKIN)
C2	1000 μ F / 35V	Rs1	0.05 Ω
C3	0.1 μ F / 50V	R1	10 Ω
C4	1 μ F / 50V		
C5	1000pF		

Note) Since the 5 pin is grounded to the substrate, these are influenced by noise when the radiator is connected to the circuit of the FG and GND lines. Under such conditions, the radiator should either be floated or an insulated seating used.

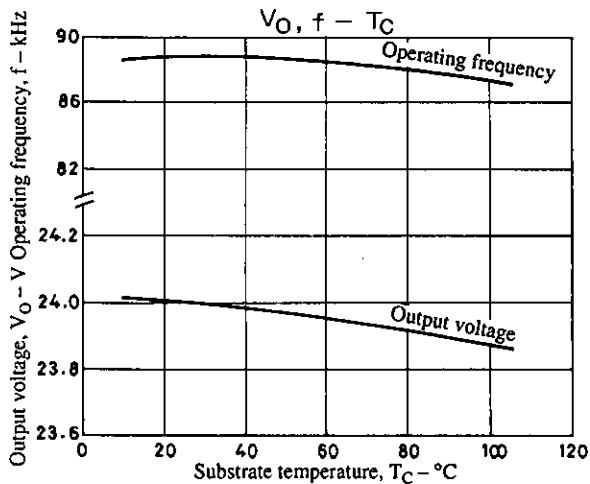
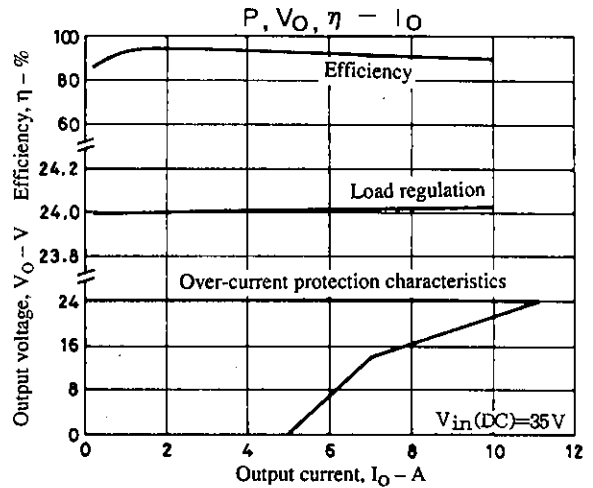
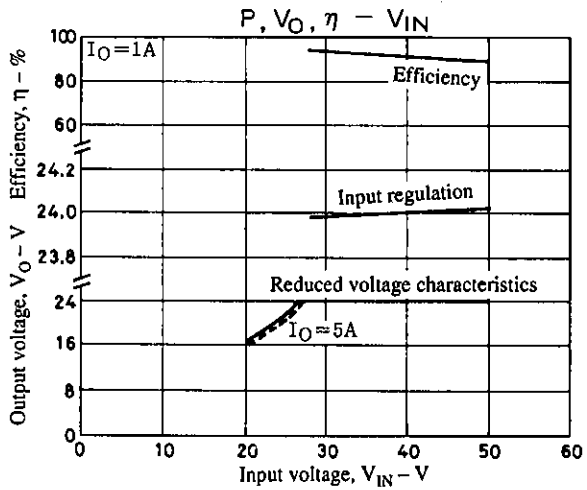

STK733C

Heat-Sink Design

Parts within the power supply block which consume electrical power are the power transistor (PTR), commutation diode (FWD), choke coil and current detection resistor. Among these, parts consuming electrical power within the hybrid IC are the PTR and FWD. When the consumption of PTR is represented by PT and that of FWD is represented by PF, the power consumed by the entire hybrid IC, Pd, and the heat resistance of the heat sink, θ_{c-a} , is determined by the following formulas:

$$P_d = (P_T + P_F) \quad [W]$$

$$\theta_{c-a} = \frac{T_c - T_a}{P_d} \quad [^{\circ}C/W]$$

T_c : Substrate temperature (105°C maximum)

T_a : Hybrid IC temperature range

In addition, the junction temperature of all devices, T_j , is calculated in the following way:

$$T_j = P_D \times \theta_{j-c} + T_c \quad [^{\circ}C]$$

P_D : Power consumption of each devices

θ_{j-c} : Thermal resistance (Junction of each device to case)

In designing heat dissipation for this IC, a heat sink thermal resistance which satisfies two temperature conditions was sought. These two temperatures consist of the junction temperature of the inner semiconductor, T_j max, and the substrate temperature of the hybrid IC, T_c max = 105°C. Because of the large influence gained from the ambient temperature and mechanisms, the heat sink has been designed to take these additional factors into consideration.

The following charts show the relation of thermal resistance and radiator area such as when the heat-sink is applied to an aluminum substrate. When a black coating is applied to the aluminum substrate surface, heat dissipation characteristics are improved and supports a 20% degree reduction thermal resistance across the entire substrate.

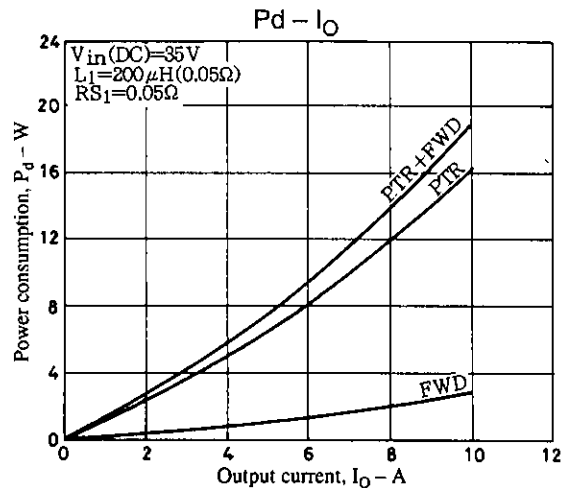
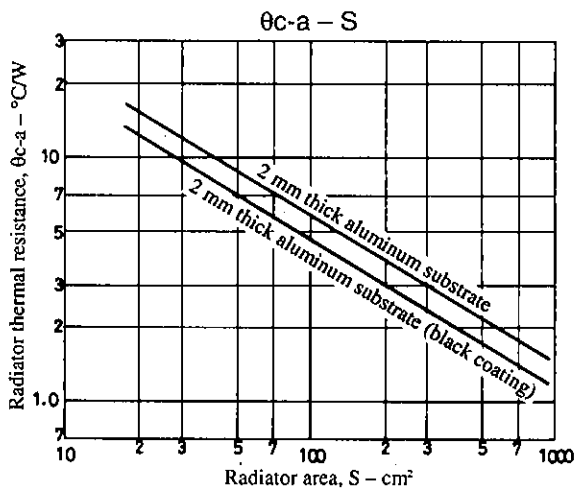

STK733C θ_{j-c} and T_j max

Item	θ_{j-c}	T_j max
PTR (FET)	3.5°C/W	150°C
FWD (FRD)	6.9°C/W	150°C

STK733C

Notes for PC Board Manufacturing

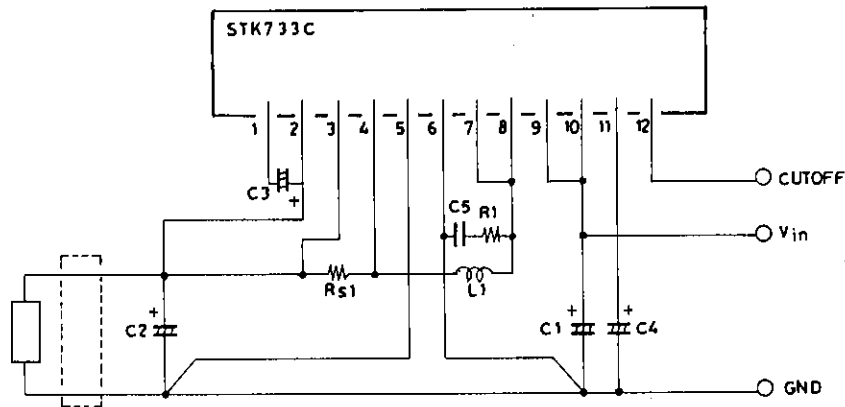

- C1 is laid out so that it is located near the IC input pin location (for protection of voltage drop by the input line and circuit pattern).
- C2 is laid out so that it is located near the load (voltage drop compensation responds to floating load).
- Pins 2 and 5 are on voltage sensing line and are tied close to the load near C2 (voltage drop compensation with circuit pattern).
- Current detection resistor Rs1 is tied in with both pin 3 and pin 4 (protects resistor detection at circuit pattern).
- Pin 6 is tied to the input capacitor C1 ground and reduces the influence of type of loop surface using thick-short lines (lessens the influence of switching spikes).
- Thickly laid out power line for large current flow.
- L and C filters added for ripple rejection are set in the [] section and the sensing line from pin 2 is tied in to the same position (C2 location) when there are no filters.
- C5 and R1 are used to lessen the effect of switching spikes and are located near the IC pin.
- Use of multi-pin application locations (such as pins 7 and 8, or pins 9 and 10) should be pattern connected even with printed boards.

Output ON/OFF Control (CUT OFF)

ON/OFF is performed using pin 12. When pin 12 switches low, output CUT OFF.

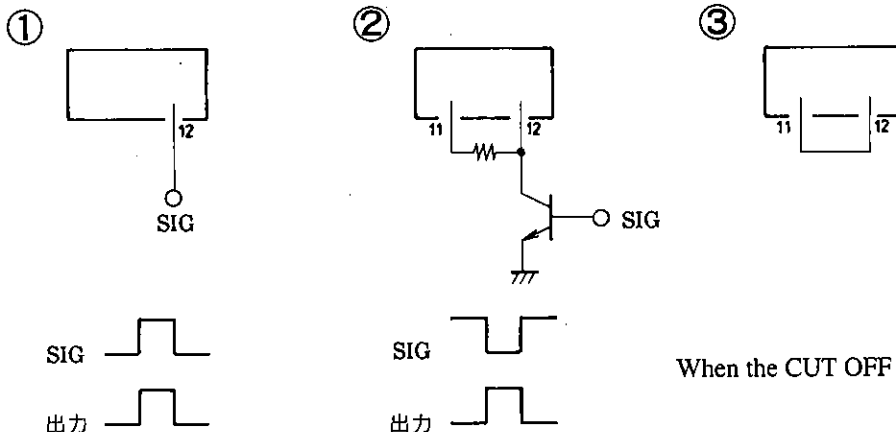

When the CUT OFF function is not used.

STK733C

Choke Coil L1

- ① The inductance value shown in the Test Circuit is at the time of zero current and is included as a reference value. Operation according to settings should be confirmed.
- ② Applications should support high-frequency with use of switching power supply.
- ③ Attention should be paid to the set standard current and magnetic saturation.

Current Detection Resistor Rs1

- ① Due to the large current flow, attention should be paid to consumption.
- ② One should be cautious of the changes in over-current protection operation points originating from resistance value unevenness.

Two Output Power Supplies Configuration Sample (STK730 Connection System)

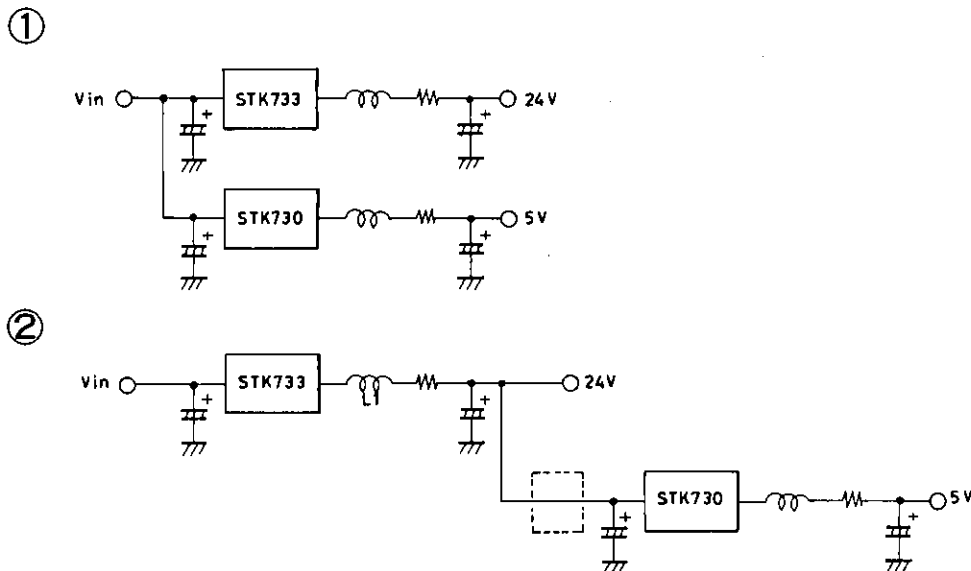

(Note) Due to the negative influences the 24 V system receives from the STK730 input ripple current and the assertion of L1, L should be installed in the [] section and the formation of a LC filter.

With the step-down chopper, overvoltage corresponding to input voltage from the output side may be generated in cases of damage or improper assembly on the PCB. In keeping with the design of the power supply, we recommend the overvoltage protection circuit settings such as a clover circuit.

- No products described or contained herein are intended for use in surgical implants, life-support systems, aerospace equipment, nuclear power control systems, vehicles, disaster/crime-prevention equipment and the like, the failure of which may directly or indirectly cause injury, death or property loss.
- Anyone purchasing any products described or contained herein for an above-mentioned use shall:
 - ① Accept full responsibility and indemnify and defend SANYO ELECTRIC CO., LTD., its affiliates, subsidiaries and distributors and all their officers and employees, jointly and severally, against any and all claims and litigation and all damages, cost and expenses associated with such use.
 - ② Not impose any responsibility for any fault or negligence which may be cited in any such claim or litigation on SANYO ELECTRIC CO., LTD., its affiliates, subsidiaries and distributors or any of their officers and employees jointly or severally.
- Information (including circuit diagrams and circuit parameters) herein is for example only; it is not guaranteed for volume production. SANYO believes information herein is accurate and reliable, but no guarantees are made or implied regarding its use or any infringements of intellectual property rights or other rights of third parties.