



# Low-Voltage, Dual-Supply, SPDT Analog Switch with Enable

MAX4564

## General Description

The MAX4564 is a low-voltage, dual-supply, single-pole/double-throw (SPDT) analog switch designed to operate from dual  $\pm 1.8\text{V}$  to  $\pm 6\text{V}$  or single  $+1.8\text{V}$  to  $+12\text{V}$  supplies. The low on-resistance ( $R_{ON} = 40\Omega$  at  $\pm 5\text{V}$ ) and low power consumption ( $5\mu\text{W}$ ) make this part ideal for audio, video, and battery-powered applications. This switch offers low leakage currents ( $1\text{nA}$  max) and fast switching speeds ( $t_{ON} = 60\text{ns}$  and  $t_{OFF} = 40\text{ns}$  at  $\pm 5\text{V}$ , max).

The MAX4564 is a second source to the Toshiba TC7W53F with lower  $R_{ON}$  and lower leakage specs. It is available in 8-pin SOT23 and  $\mu\text{MAX}$  packages.

## Applications

- Battery-Operated Systems
- Audio and Video Switching
- Test Equipment
- Communications Circuits
- Sample-and-Hold Circuits
- Communications Systems

## Features

- ◆  $60\Omega$  max ( $40\Omega$  typ) On-Resistance ( $R_{ON}$ )
- ◆  $3\Omega$  max ( $0.75\Omega$  typ)  $R_{ON}$  Matching Between Channels
- ◆  $10\Omega$  (max)  $R_{ON}$  Flatness
- ◆ Low Charge Injection:  $3\text{pC}$  (typ)
- ◆ Low  $\pm 1\text{nA}$  Leakage Current at  $+25^\circ\text{C}$
- ◆ Fast Switching  
 $t_{ON} = 60\text{ns}$  (max)  
 $t_{OFF} = 40\text{ns}$  (max)
- ◆ Guaranteed Break-Before-Make Switching
- ◆ TTL/CMOS-Logic Compatible
- ◆ Low Crosstalk:  $-72\text{dB}$  ( $1\text{MHz}$ )
- ◆ High Off-Isolation:  $-77\text{dB}$  ( $1\text{MHz}$ )
- ◆ Bandwidth  $-3\text{dB}$ :  $>450\text{MHz}$  (typ)
- ◆ Available in an 8-Pin SOT23 Package

## Ordering Information

PART	TEMP. RANGE	PIN-PACKAGE
MAX4564EKA-T	$-40^\circ\text{C}$ to $+85^\circ\text{C}$	8 SOT23
MAX4564EUA	$-40^\circ\text{C}$ to $+85^\circ\text{C}$	8 $\mu\text{MAX}$

## Functional Diagrams/Pin Configurations/Truth Table



$\overline{\text{EN}}$	IN	NC	NO
0	0	ON	OFF
0	1	OFF	ON
1	X	OFF	OFF

x = Don't care

# Low-Voltage, Dual-Supply, SPDT Analog Switch with Enable

## ABSOLUTE MAXIMUM RATINGS

(Voltages Referenced to GND)

V+	-0.3V to +13V
V-	-13V to +0.3V
V+ to V-	-0.3V to +13V
$\overline{EN}$ , IN, COM, NC, NO (Note 1)	(V- - 0.3V) to (V+ + 0.3V)
Continuous Current (any terminal)	±20mA
Peak Current, COM, NC, NO (pulsed at 1ms, 10% duty cycle)	±30mA
ESD per Method 3015.7	>2kV

Continuous Power Dissipation ( $T_A = +70^\circ\text{C}$ )

8-Pin SOT23 (derate 7.1mW/°C above +70°C)	571mW
8-Pin $\mu\text{MAX}$ (derate 4.10mW/°C above +70°C)	330mW
Operating Temperature Range MAX4564E_A	-40°C to +85°C
Junction Temperature	+150°C
Storage Temperature Range	-65°C to +150°C
Lead Temperature (soldering, 10s)	+300°C

**Note 1:** Signals on NO, NC, COM, IN, or  $\overline{EN}$  exceeding V+ or V- are clamped by internal diodes. Limit forward-diode current to maximum current rating.

Stresses beyond those listed under "Absolute Maximum Ratings" may cause permanent damage to the device. These are stress ratings only, and functional operation of the device at these or any other conditions beyond those indicated in the operational sections of the specifications is not implied. Exposure to absolute maximum rating conditions for extended periods may affect device reliability.

## ELECTRICAL CHARACTERISTICS—±5V Supply

(V+ = +4.5V to +6V, V- = -4.5V to -6V,  $V_{IH} = +2.4\text{V}$ ,  $V_{IL} = +0.8\text{V}$ , GND = 0,  $T_A = T_{MIN}$  to  $T_{MAX}$ , unless otherwise noted. Typical values are at  $T_A = +25^\circ\text{C}$ .) (Notes 2, 3)

PARAMETER	SYMBOL	CONDITIONS	$T_A$	MIN	TYP	MAX	UNITS
<b>ANALOG SWITCH</b>							
Analog Signal Range	$V_{COM}$ , $V_{NO}$ , $V_{NC}$			V-		V+	V
On-Resistance	$R_{ON}$	V+ = +4.5V, V- = -4.5V, $I_{COM} = 1\text{mA}$ ; $V_{NO}$ , $V_{NC} = \pm 3.5\text{V}$	+25°C	40	60		$\Omega$
			E		100		
On-Resistance Match Between Channels (Note 4)	$\Delta R_{ON}$	V+ = +4.5V, V- = -4.5V, $I_{COM} = 1\text{mA}$ ; $V_{NO}$ , $V_{NC} = \pm 3.5\text{V}$	+25°C	0.75	3		$\Omega$
			E		4		
On-Resistance Flatness (Note 5)	$R_{FLAT(ON)}$	V+ = +4.5V, V- = -4.5V, $I_{COM} = 1\text{mA}$ ; $V_{NO}$ , $V_{NC} = -3.5\text{V}$ , 0, +3.5V	+25°C	6.5	10		$\Omega$
			E		13		
NO or NC Off-Leakage Current	$I_{NC(OFF)}$ or $I_{NO(OFF)}$	V+ = +5.5V, V- = -5.5V; $V_{COM} = +4.5\text{V}$ , -4.5V; $V_{NO}$ , $V_{NC} = -4.5$ , +4.5V	+25°C	-1	0.05	1	nA
			E	-5		5	
COM Off-Leakage Current	$I_{COM(OFF)}$	V+ = +5.5V, V- = -5.5V; $V_{COM} = +4.5\text{V}$ , -4.5V; $V_{NO}$ , $V_{NC} = -4.5$ , +4.5V	+25°C	-1	0.05	1	nA
			E	-5		5	
COM On-Leakage Current	$I_{COM(ON)}$	V+ = +5.5V, V- = -5.5V, $V_{COM} = +4.5\text{V}$ , -4.5V; $V_{NO}$ , $V_{NC} = +4.5\text{V}$ , -4.5V, or floating	+25°C	-2	0.05	2	nA
			E	-10		10	

# Low-Voltage, Dual-Supply, SPDT Analog Switch with Enable

**MAX4564**

## ELECTRICAL CHARACTERISTICS—±5V Supply (continued)

(V+ = +4.5V to +6V, V- = -4.5V to -6V, VIH = +2.4V, VIL = +0.8V, GND = 0, TA = TMIN to TMAX, unless otherwise noted. Typical values are at TA = +25°C.) (Notes 2, 3)

PARAMETER	SYMBOL	CONDITIONS	TA	MIN	TYP	MAX	UNITS
<b>SWITCH DYNAMIC CHARACTERISTICS</b>							
Turn-On Time	tON	VNO, VNC = +3V, -3V, RL = 1kΩ, CL = 35pF	+25°C	40	60		ns
			E			75	
Turn-Off Time	tOFF	VNO, VNC = +3V, -3V, RL = 1kΩ, CL = 35pF	+25°C	28	40		ns
			E			50	
Transition Time	tTRANS	VNC = +3V, VNO = -3V, VNC = -3V, VNO = +3V, RL = 1kΩ, CL = 35pF	+25°C	50	70		ns
			E			85	
Break-Before-Make Time (Note 6)	tBBM	VNO, VNC = +3V, -3V, RL = 300Ω, CL = 35pF	+25°C	5	15		ns
Charge Injection	Q	VGEN = 0, RGEN = 0, CL = 100pF	+25°C		3		pC
-3dB Bandwidth	f-3dB	RL = 50Ω, CL = 10pF, f0dB = 1MHz	+25°C		450		MHz
Off-Isolation (Note 7)	VISO	RL = 50Ω, CL = 10pF, fIN = 1MHz	+25°C		-77		dB
Crosstalk (Control Input to Signal Output)		RL = 50Ω, CL = 10pF, V+ = +4.5V, V- = -4.5V, fIN = 1MHz, VEN = VIH	+25°C		68		mV
Crosstalk (Between Switches)	VCT	RL = 50Ω, CL = 10pF, fIN = 1MHz	+25°C		-72		dB
Total Harmonic Distortion	THD	RL = 600kΩ, CL = 50pF, fIN = 20kHz	+25°C		0.15		%
Control Input Capacitance	CIN				3		pF
NO or NC Off-Capacitance	COFF	fIN = 1MHz	+25°C		6		pF
COM Off-Capacitance	CCOM(OFF)	fIN = 1MHz	+25°C		8		pF
COM On-Capacitance	CCOM(ON)	fIN = 1MHz	+25°C		14		pF
<b>LOGIC INPUT</b>							
Input Voltage Low	VIL					0.8	V
Input Voltage High	VIH			2.4			V
Input Leakage Current	IL	V+ = +5.5V, V- = -5.5V, VIN = VEN = 0 or +5.5V	+25°C	-1	0.0001	1	μA
			E	-10		10	
<b>POWER SUPPLY</b>							
Power-Supply Range	V+			2		6	V
	V-			-2		-6	
Positive Supply Current	I+	V+ = +5.5V, V- = -5.5V, VIN = VEN = 0 or +5.5V	+25°C	-1	0.0001	1	μA
			E	-10		10	
Negative Supply Current	I-	V+ = +5.5V, V- = -5.5V, VIN = VEN = 0 or +5.5V	+25°C	-1	0.0001	1	μA
			E	-10		10	

# Low-Voltage, Dual-Supply, SPDT Analog Switch with Enable

## ELECTRICAL CHARACTERISTICS—Single +5V Supply

( $V_+ = +4.5V$  to  $+6V$ ,  $V_- = 0$ ,  $V_{IH} = +2.4V$ ,  $V_{IL} = +0.8V$ ,  $GND = 0$ ,  $T_A = T_{MIN}$  to  $T_{MAX}$ , unless otherwise noted. Typical values are at  $T_A = +25^\circ C$ .) (Notes 2, 3)

PARAMETER	SYMBOL	CONDITIONS	$T_A$	MIN	TYP	MAX	UNITS	
<b>ANALOG SWITCH</b>								
Analog Signal Range	$V_{COM}$ , $V_{NO}$ , $V_{NC}$			0		$V_+$	V	
On-Resistance	$R_{ON}$	$V_+ = +4.5V$ , $V_- = 0$ , $I_{COM} = 1mA$ ; $V_{NO}$ , $V_{NC} = +3.5V$	$+25^\circ C$		72	100	$\Omega$	
			E			125		
On-Resistance Match Between Channels (Note 4)	$\Delta R_{ON}$	$V_+ = +4.5V$ , $V_- = 0$ , $I_{COM} = 1mA$ ; $V_{NO}$ , $V_{NC} = +3.5V$	$+25^\circ C$		0.75	5	$\Omega$	
			E			7		
<b>SWITCH DYNAMIC CHARACTERISTICS</b>								
Turn-On Time	$t_{ON}$	$V_{NO}$ , $V_{NC} = +3V$ , $R_L = 1k\Omega$ , $C_L = 35pF$	$+25^\circ C$		62	90	ns	
			E			125		
Turn-Off Time	$t_{OFF}$	$V_{NO}$ , $V_{NC} = +3V$ , $R_L = 1k\Omega$ , $C_L = 35pF$	$+25^\circ C$		22	60	ns	
			E			75		
Transition Time	$t_{TRANS}$	$V_{NC} = +3V$ , $V_{NO} = 0$ , $V_{NC} = 0$ , $V_{NO} = +3V$ , $R_L = 1k\Omega$ , $C_L = 35pF$	$+25^\circ C$		68	100	ns	
			E			130		
Break-Before-Make Time (Note 6)	$t_{BBM}$	$V_{NO}$ , $V_{NC} = +3V$ , $R_L = 300\Omega$ , $C_L = 35pF$	E		10	35	ns	
<b>LOGIC INPUT</b>								
Input Voltage Low	$V_{IL}$					0.8	V	
Input Voltage High	$V_{IH}$			2.4			V	
Input Leakage Current	$I_L$	$V_+ = +5.5V$ , $V_- = 0$ , $V_{IN} = V_{\overline{EN}} = 0$ or $+5.5V$	$+25^\circ C$		-1	0.0001	1	$\mu A$
			E			-10	10	
<b>POWER SUPPLY</b>								
Power-Supply Range	$V_+$			1.8		12	V	
Positive Supply Current	$I_+$	$V_+ = +5.5V$ , $V_- = 0$ , $V_{IN} = V_{\overline{EN}} = 0$ or $+5.5V$	$+25^\circ C$		-1	0.0001	1	$\mu A$
			E			-10	10	
Negative Supply Current	$I_-$	$V_+ = +5.5V$ , $V_- = 0$ , $V_{IN} = V_{\overline{EN}} = 0$ or $+5.5V$	$+25^\circ C$		-1	0.0001	1	$\mu A$
			E			-10	10	

# Low-Voltage, Dual-Supply, SPDT Analog Switch with Enable

MAX4564

## ELECTRICAL CHARACTERISTICS—Single +3V Supply

( $V_+ = +2.7V$  to  $+3.3V$ ,  $V_- = 0$ ,  $V_{IH} = +2.4V$ ,  $V_{IL} = +0.8V$ ,  $GND = 0$ ,  $T_A = T_{MIN}$  to  $T_{MAX}$ , unless otherwise noted. Typical values are at  $T_A = +25^\circ C$ .) (Notes 2, 3)

PARAMETER	SYMBOL	CONDITIONS	$T_A$	MIN	TYP	MAX	UNITS
<b>ANALOG SWITCH</b>							
Analog Signal Range	$V_{COM}$ , $V_{NO}$ , $V_{NC}$			0		$V_+$	V
On-Resistance	$R_{ON}$	$V_+ = +2.7V$ , $V_- = 0$ , $I_{COM} = 1mA$ ; $V_{NO}$ , $V_{NC} = +1.5V$	+25°C	160	275		$\Omega$
			E			300	
On-Resistance Match Between Channels (Note 4)	$\Delta R_{ON}$	$V_+ = +2.7V$ , $V_- = 0$ , $I_{COM} = 1mA$ ; $V_{NO}$ , $V_{NC} = +1.5V$	+25°C	1.5	10		$\Omega$
			E			12	
<b>SWITCH DYNAMIC CHARACTERISTICS</b>							
Turn-On Time	$t_{ON}$	$V_{NO}$ , $V_{NC} = +1.5V$ , $R_L = 2k\Omega$ , $C_L = 35pF$	+25°C	120	250		ns
			E			275	
Turn-Off Time	$t_{OFF}$	$V_{NO}$ , $V_{NC} = +1.5V$ , $R_L = 2k\Omega$ , $C_L = 35pF$	+25°C	40	110		ns
			E			125	
Break-Before-Make Time (Note 6)	$t_{BBM}$	$V_{NO}$ , $V_{NC} = +1.5V$ , $R_L = 2k\Omega$ , $C_L = 35pF$	E	10			ns
<b>LOGIC INPUT</b>							
Input Voltage Low	$V_{IL}$					0.8	V
Input Voltage High	$V_{IH}$			2.4			V
Input Leakage Current	$I_L$	$V_+ = +3.3V$ , $V_- = 0$ , $V_{IN} = V_{EN} = 0$ or $+3.3V$	+25°C	-1	0.0001	1	$\mu A$
			E	-10		10	

**Note 2:** The algebraic convention is used in this data sheet; the most negative value is shown in the minimum column.

**Note 3:** SOT-packaged products are 100% tested at +25°C and guaranteed by design at the full-rated temperature.

**Note 4:**  $\Delta R_{ON} = R_{ON(MAX)} - R_{ON(MIN)}$ .

**Note 5:** Flatness is defined as the difference between the maximum and minimum value of on-resistance as measured over the specified analog signal ranges.

**Note 6:** Guaranteed by design.

**Note 7:** Off-Isolation =  $20\log_{10}(V_{COM} / V_{NO})$ ,  $V_{NO}$  = input to off switch.

# Low-Voltage, Dual-Supply, SPDT Analog Switch with Enable

## Typical Operating Characteristics

( $T_A = +25^\circ\text{C}$ , unless otherwise noted.)

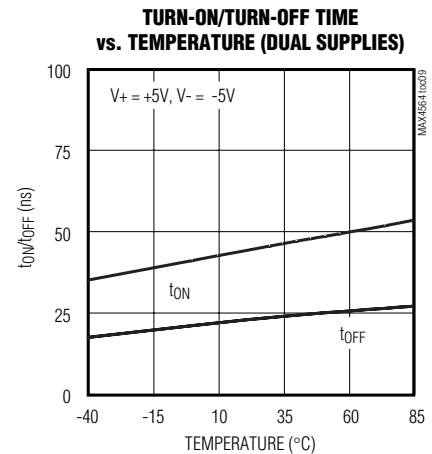
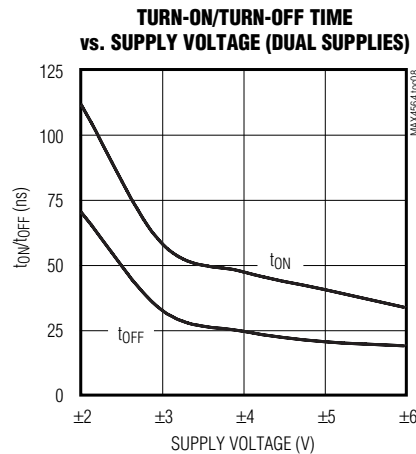
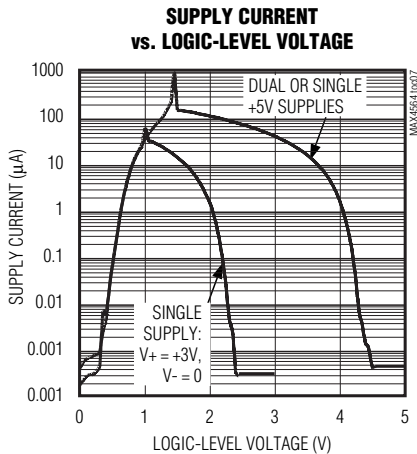
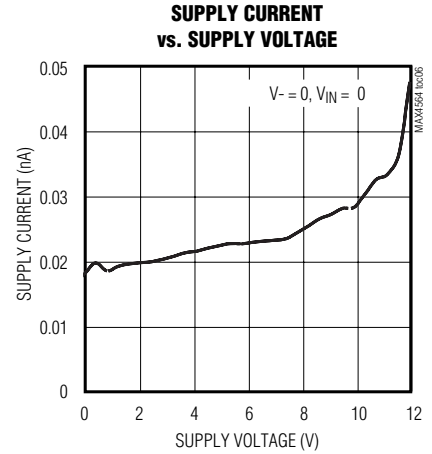
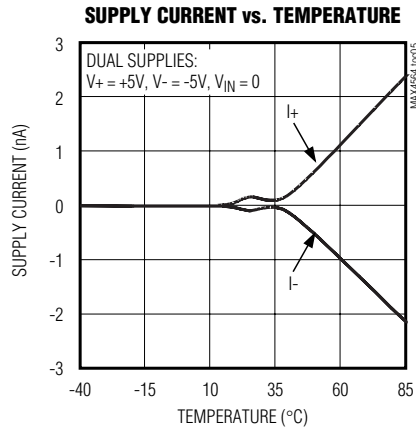
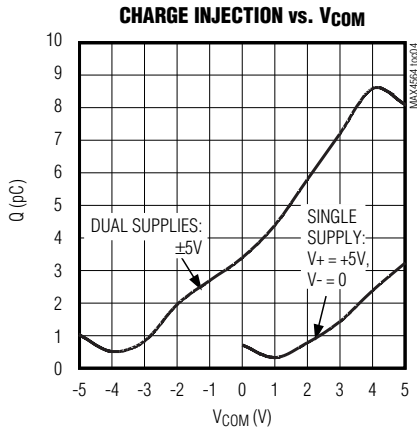
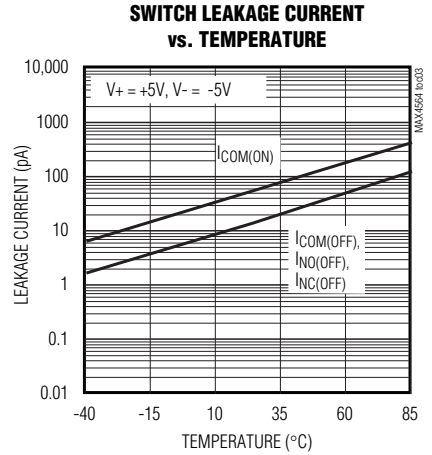
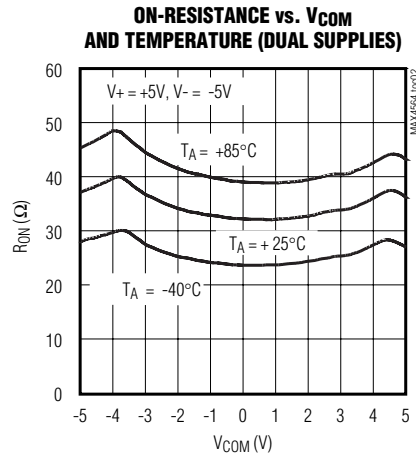
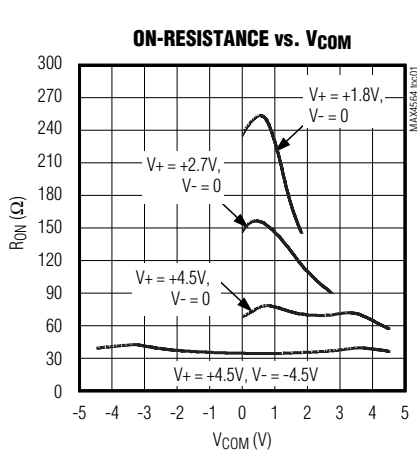

# Low-Voltage, Dual-Supply, SPDT Analog Switch with Enable

## Typical Operating Characteristics (continued)

( $T_A = +25^\circ\text{C}$ , unless otherwise noted.)

MAX4564

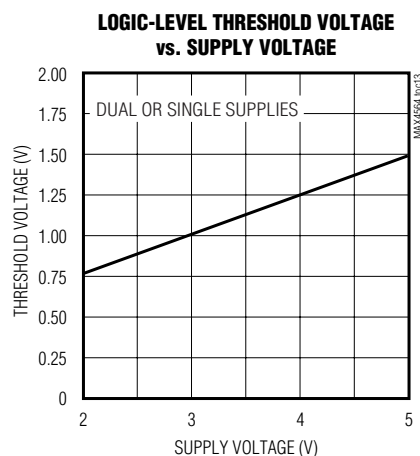
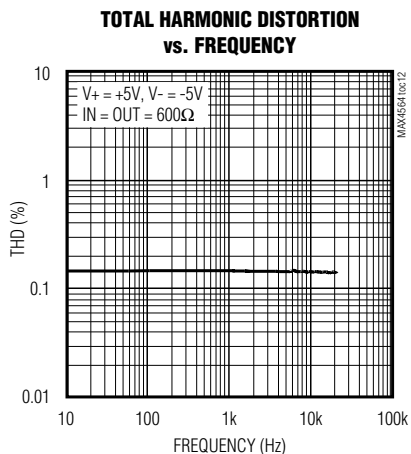
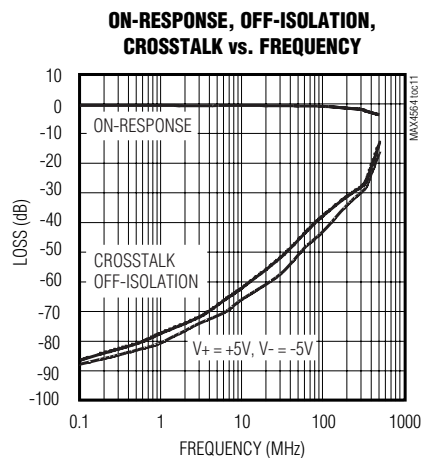
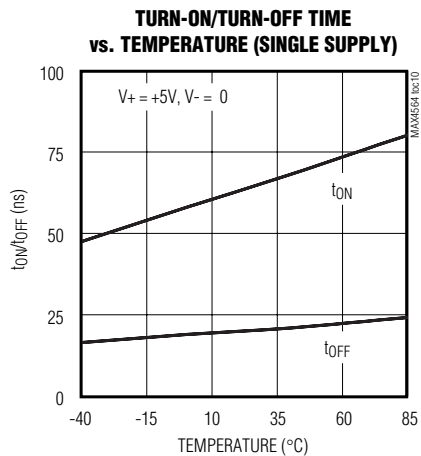

# Low-Voltage, Dual-Supply, SPDT Analog Switch with Enable

## Pin Description

$\mu$ MAX	SOT23	NAME	FUNCTION
1	8	COM	Analog Switch Common
2	7	$\overline{\text{EN}}$	Device Enable. Drive $\overline{\text{EN}}$ low for normal SPDT switch operation. If $\overline{\text{EN}}$ is high, both NO and NC are disconnected.
3	6	V-	Negative Supply Voltage
4	5	GND	Ground
5	3	IN	Digital Control Input
6	4	NO	Analog Switch Normally Open
7	1	NC	Analog Switch Normally Closed
8	2	V+	Positive Supply Voltage

## Detailed Description

The MAX4564 is a dual-supply SPDT CMOS analog switch. The MAX4564 has break-before-make switching. The CMOS switch construction provides Rail-to-Rail<sup>®</sup> signal handling while consuming virtually no power. Each of the two switches is independently controlled by a TTL/CMOS-level-compatible digital input.

## Applications Information

### Overvoltage Protection

Do not exceed the absolute maximum ratings because stresses beyond the listed ratings may cause permanent damage to the device. Proper power-supply sequencing is recommended for all CMOS devices. Always sequence V+ on first, then V-, followed by the logic inputs NO, NC, or COM. If power-supply sequencing is not possible, add two small-signal diodes (D1, D2) in series with supply pins. Adding diodes reduces the analog signal range to one diode drop below V+ and one diode drop above V-, but does not affect the device's low switch resistance and low leakage characteristics.

## Test Circuits/ Timing Diagrams

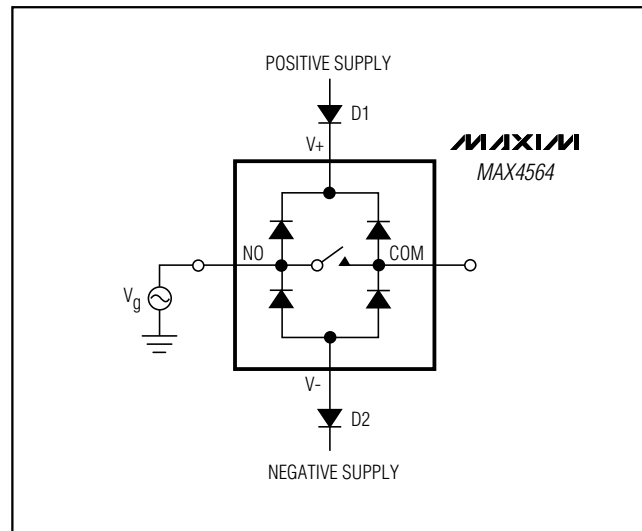

Figure 1. Overvoltage Protection Using Two External Blocking Diodes



# Low-Voltage, Dual-Supply, SPDT Analog Switch with Enable

## Test Circuits/Timing Diagrams (continued)

MAX4564

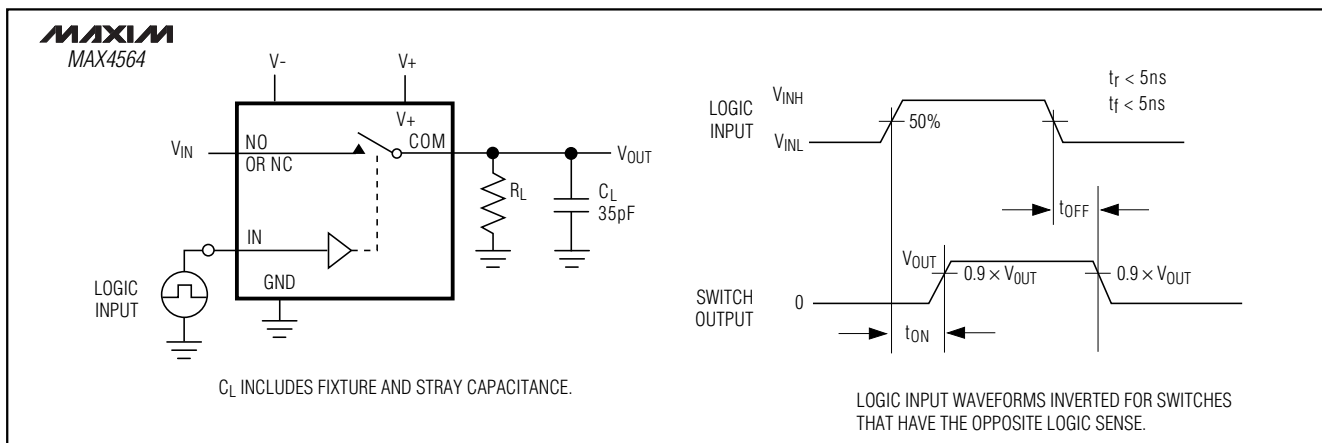

Figure 2. Switching Time

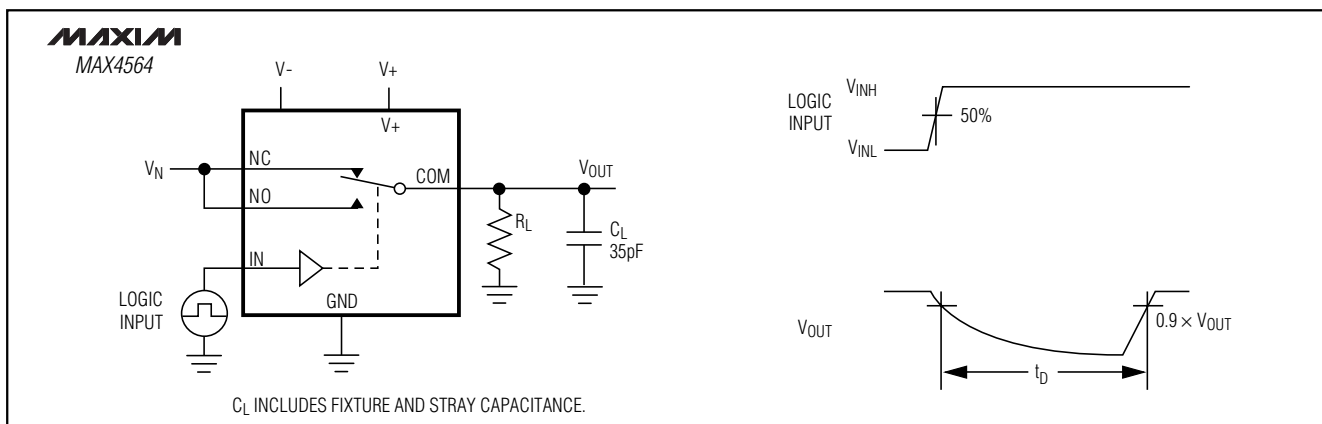

Figure 3. Break-Before-Make Interval

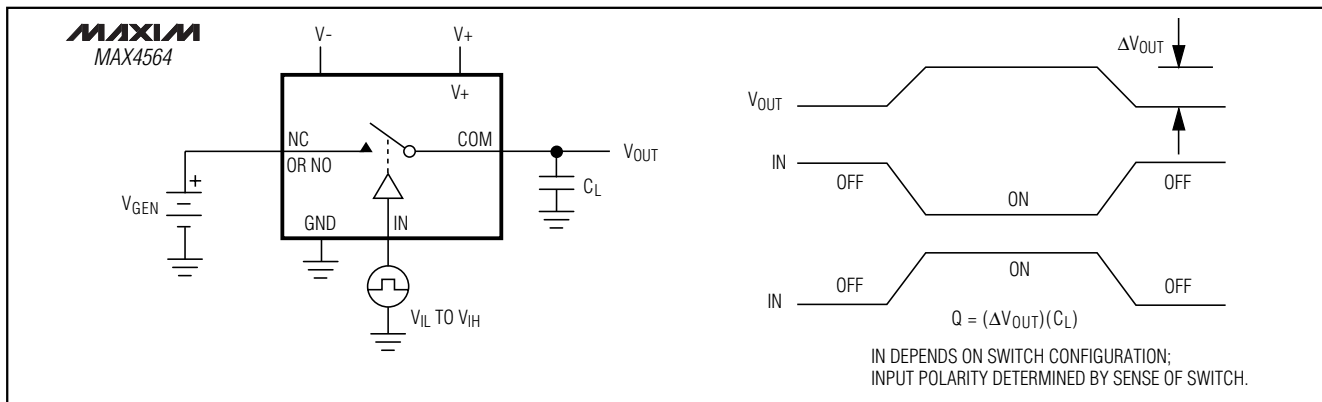

Figure 4. Charge Injection

# Low-Voltage, Dual-Supply, SPDT Analog Switch with Enable

## Test Circuits/Timing Diagrams (continued)

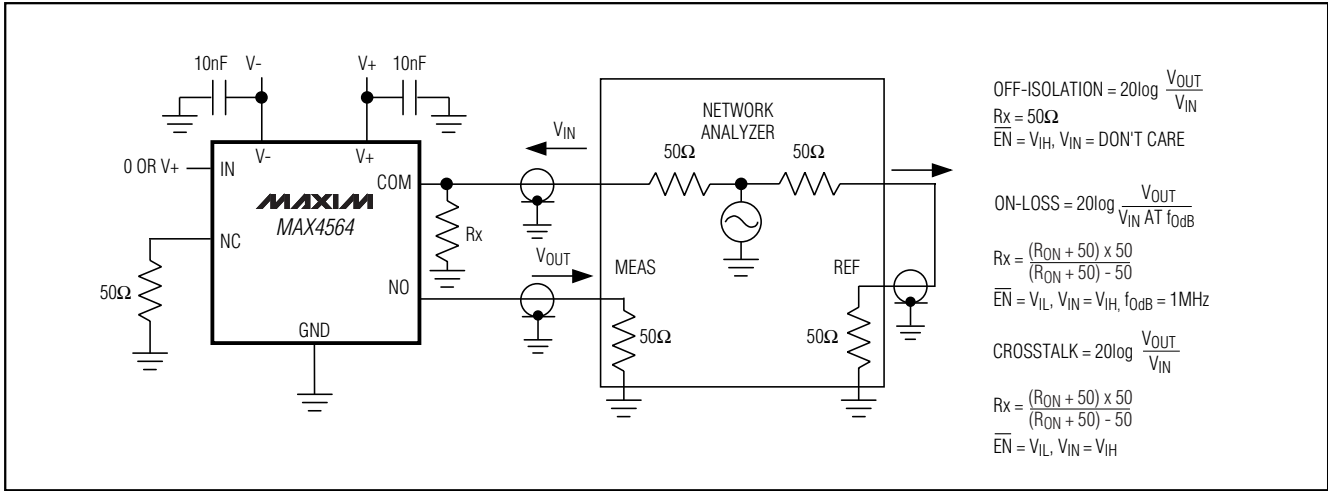

Figure 5. On-Loss, Off-Isolation, and Crosstalk

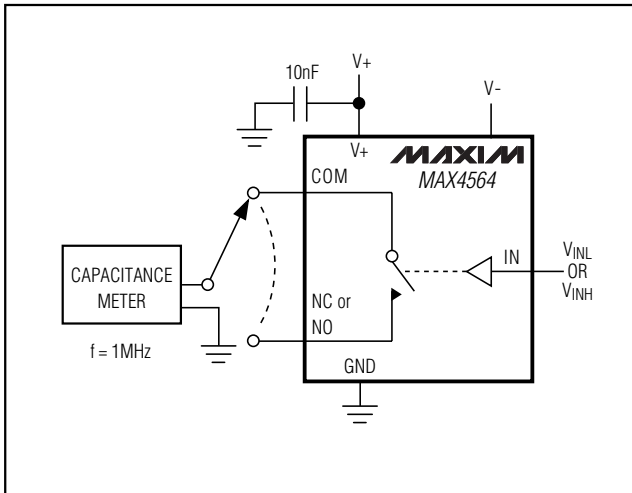

Figure 6. Channel Off/On-Capacitance

## Chip Information

TRANSISTOR COUNT: 116

PROCESS : CMOS

# Low-Voltage, Dual-Supply, SPDT Analog Switch with Enable

## Package Information

**MAX4564**

SOT23, 8LEPS

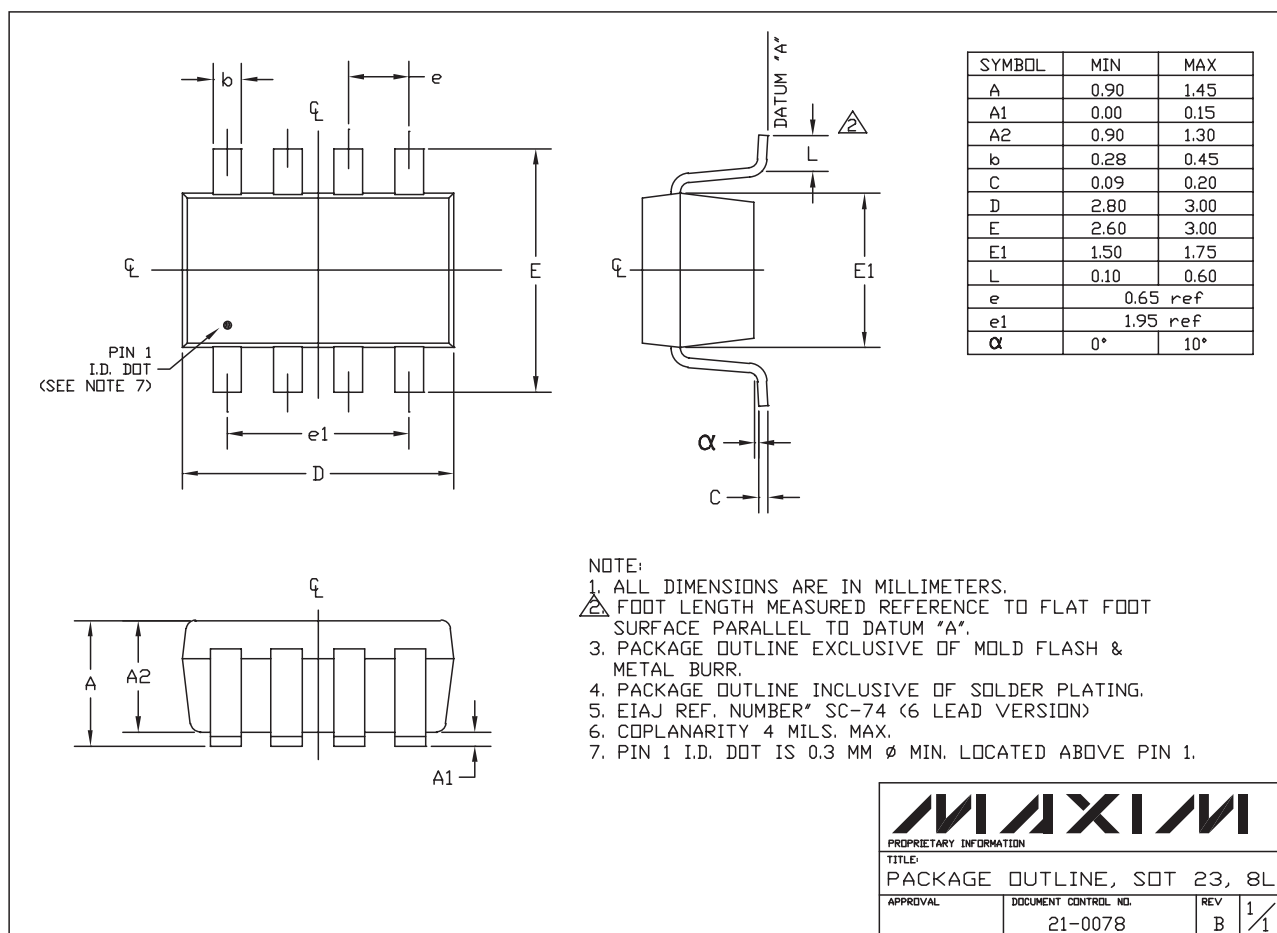

**MAXIM**  
 PROPRIETARY INFORMATION  
 TITLE:  
 PACKAGE OUTLINE, SOT 23, 8L  
 APPROVAL: \_\_\_\_\_ DOCUMENT CONTROL NO. 21-0078 REV B 1/1

# Low-Voltage, Dual-Supply, SPDT Analog Switch with Enable

## Package Information (continued)

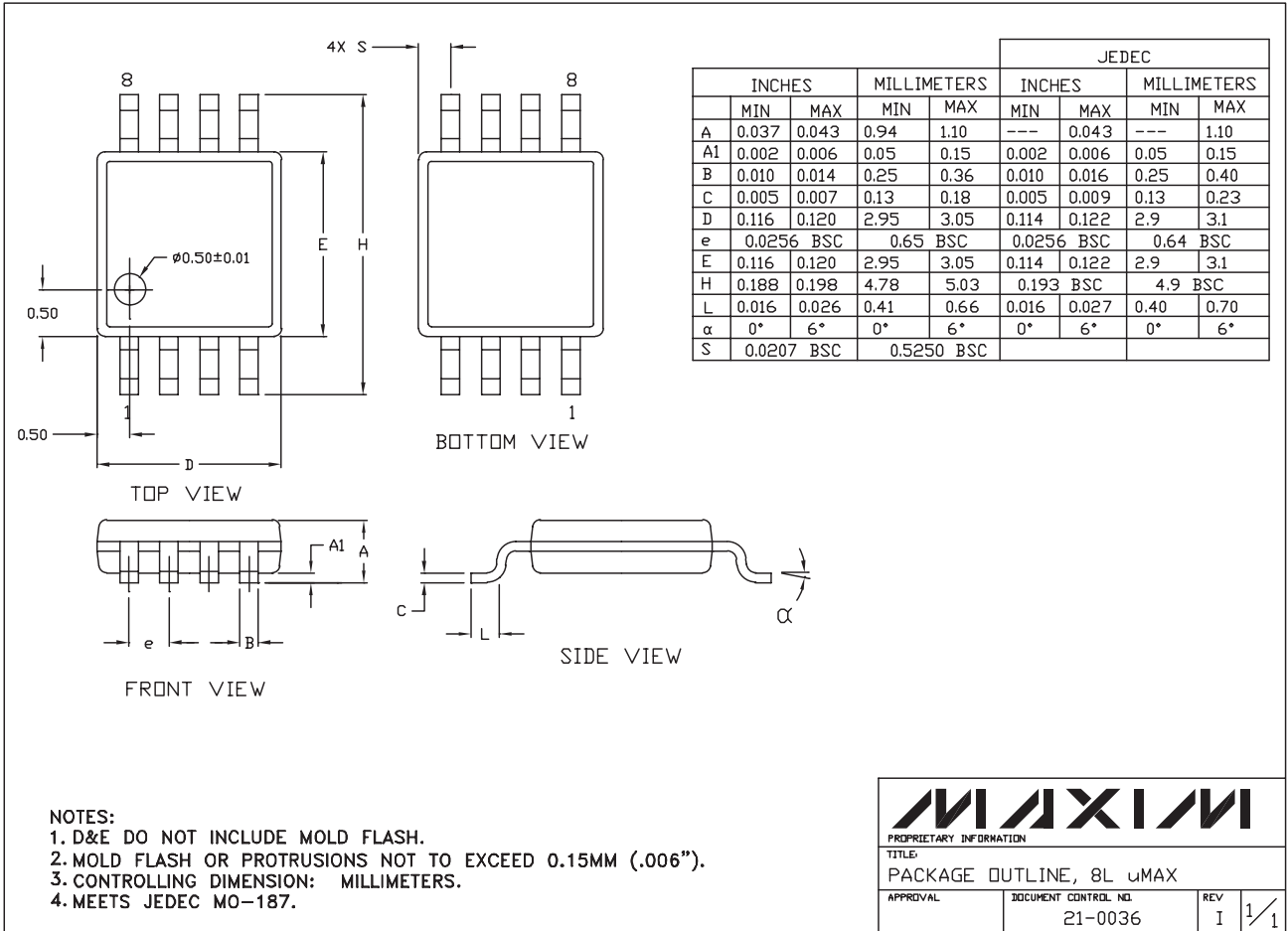

8LUMAXDEFS

Maxim cannot assume responsibility for use of any circuitry other than circuitry entirely embodied in a Maxim product. No circuit patent licenses are implied. Maxim reserves the right to change the circuitry and specifications without notice at any time.