



# 2-Wire Interfaced, 5 × 7 Matrix Vacuum-Fluorescent Display Controller

MAX6853

## General Description

The MAX6853 compact vacuum-fluorescent display (VFD) controller provides microprocessors with the multiplex timing for 5 x 7 matrix VFD displays up to 96 characters and controls industry-standard, shift-register, high-voltage grid/anode VFD tube drivers. The device supports display tubes using either one or two digits per grid, as well as universal displays. The MAX6853 provides an internal crosspoint switch to match any tube-driver shift-register grid/anode order, and is compatible with both chip-in-glass and external tube drivers. Hardware is included to simplify the generation of cathode bias and filament supplies and to provide up to five logic outputs, including a buzzer driver.

The MAX6853 includes an ASCII 104-character font, multiplex scan circuitry, and static RAM that stores digit, cursor, and annunciator data, as well as font data for 24 user-definable characters. An internal 16-step digital brightness control adjusts the display intensity. The device also includes separate annunciator and cursor control with automatic blinking, as well as a low-power shutdown mode.

The MAX6853 provides timing to generate the PWM waveforms to drive the tube filament from a DC supply. The filament drive is synchronized to the display multiplexing to eliminate beat artifacts.

For an SPI™-compatible version, refer to the MAX6852 data sheet.

## Applications

- Display Modules
- Retail POS Displays
- Weight and Tare Displays
- Bar Graph Displays
- Industrial Controllers

Pin Configuration and Functional Diagram appear at end of data sheet.

SPI is a trademark of Motorola, Inc.

## Features

- ◆ 400kbps 2-Wire I<sup>2</sup>C-Compatible Interface
- ◆ 2.7V to 3.6V Operation
- ◆ Controls Up to 96 5 x 7 Matrix Characters
- ◆ One Digit and Two Digits per Grid and Universal Displays Supported
- ◆ 16-Step Digital Brightness Control
- ◆ Built-In ASCII 104-Character Font
- ◆ 24 User-Definable Characters
- ◆ Up to Four Annunciators per Grid with Automatic Blinking Control
- ◆ Separate Cursor Control with Automatic Blinking
- ◆ Filament Drive Full-Bridge Waveform Synthesis
- ◆ Buzzer Tone Generator with Single-Ended or Push-Pull Driver
- ◆ Up to Five General-Purpose Logic Outputs
- ◆ 9µA Low-Power Shutdown (Data Retained)
- ◆ 16-Pin QSOP Package

## Ordering Information

PART	TEMP RANGE	PIN-PACKAGE
MAX6853AEE	-40°C to +125°C	16 QSOP

## Typical Application Circuit

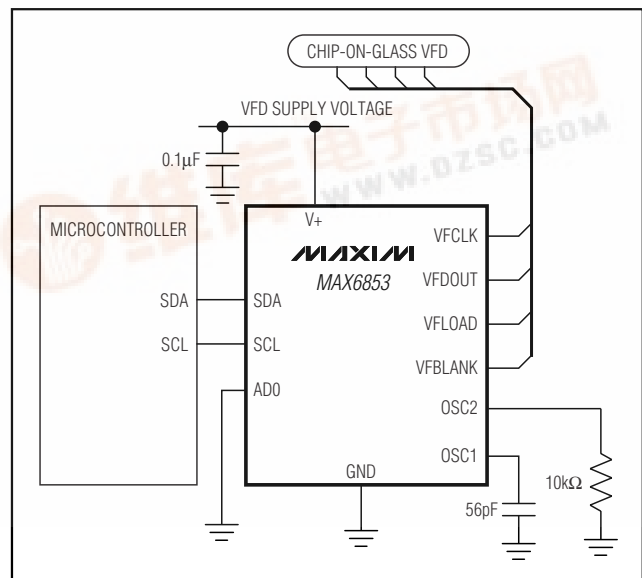

# 2-Wire Interfaced, 5 × 7 Matrix Vacuum-Fluorescent Display Controller

## ABSOLUTE MAXIMUM RATINGS

Voltage (with respect to GND)	
V+ .....	-0.3V to +4V
AD0, SDA, SCL .....	-0.3V to +5.5V
All Other Pins .....	-0.3V to (V+ + 0.3V)
Current	
V+ .....	200mA
GND .....	200mA
PHASE1, PHASE2, PORT0, PORT1, PUMP .....	±150mA
VFCLK, VFDOUT, VFLOAD, VFBLANK .....	±150mA
SDA .....	15mA

Continuous Power Dissipation (T <sub>A</sub> = +70°C)	
16-Pin QSOP (derate at 8.34mW/°C above +70°C) .....	667mW
Operating Temperature Range (T <sub>MIN</sub> , T <sub>MAX</sub> )	
MAX6853AEE .....	-40°C to +125°C
Junction Temperature .....	+150°C
Storage Temperature Range .....	-65°C to +150°C
Lead Temperature (soldering, 10s) .....	+300°C

Stresses beyond those listed under "Absolute Maximum Ratings" may cause permanent damage to the device. These are stress ratings only, and functional operation of the device at these or any other conditions beyond those indicated in the operational sections of the specifications is not implied. Exposure to absolute maximum rating conditions for extended periods may affect device reliability.

## DC ELECTRICAL CHARACTERISTICS

(Typical operating circuit, V+ = 2.7V to 3.6V, T<sub>A</sub> = T<sub>MIN</sub> to T<sub>MAX</sub>, unless otherwise noted.) (Note 1)

PARAMETER	SYMBOL	CONDITIONS	MIN	TYP	MAX	UNITS
Operating Supply Voltage	V+		2.7		3.6	V
Shutdown Supply Current	I <sub>SHDN</sub>	Shutdown mode, all digital inputs at V+ or GND	T <sub>A</sub> = T <sub>MIN</sub> to T <sub>MAX</sub>		160	μA
			T <sub>A</sub> = +25°C	9	20	
Operating Supply Current	I+	OSC = 4MHz VFLOAD, VFDOUT, VFCLK, VFBLANK, loaded 100pF	T <sub>A</sub> = T <sub>MIN</sub> to T <sub>MAX</sub>		3	mA
			T <sub>A</sub> = +25°C	1.65	2	
Master Clock Frequency (OSC Internal Oscillator)	f <sub>OSC</sub>	OSC1 fitted with C <sub>OSC</sub> = 56pF, OSC2 fitted with R <sub>OSC</sub> = 10kΩ; see the <i>Typical Operating Circuit</i>		4		MHz
Master Clock Frequency (OSC External Oscillator)		OSC1 overdriven with external f <sub>OSC</sub>	2		8	MHz
Dead-Clock Protection Frequency				200		kHz
OSC High Time	t <sub>CH</sub>		50			ns
OSC Low Time	t <sub>CL</sub>		50			ns
Fast or Slow Segment Blink Duty Cycle		(Note 2)	49.5		50.5	%
<b>LOGIC INPUTS AND OUTPUTS</b>						
Input Leakage Current AD0, SDA, SCL	I <sub>IH</sub> , I <sub>IL</sub>			0.2	1	μA
Logic-High Input Voltage AD0, SDA, SCL	V <sub>IH</sub>		2.4			V
Logic-Low Input Voltage AD0, SDA, SCL	V <sub>IL</sub>				0.6	V
SDA Output Low Voltage	V <sub>OLSDA</sub>	I <sub>SINK</sub> = 3mA			0.5	V
Input Capacitance	C <sub>I</sub>				10	pF

## 2-Wire Interfaced, 5 × 7 Matrix Vacuum-Fluorescent Display Controller

**MAX6853**

### DC ELECTRICAL CHARACTERISTICS (continued)

(Typical operating circuit, V+ = 2.7V to 3.6V, T<sub>A</sub> = T<sub>MIN</sub> to T<sub>MAX</sub>, unless otherwise noted.) (Note 1)

PARAMETER	SYMBOL	CONDITIONS	MIN	TYP	MAX	UNITS
Output Rise and Fall Time PHASE1, PHASE2, PORT0, PORT1, PUMP, VFLOAD, VFDOUT, VFCLK, VFBLANK	t <sub>RFT</sub>	C <sub>LOAD</sub> = 100pF			25	ns
Output High-Voltage PHASE1, PHASE2, PORT0, PORT1, PUMP, VFLOAD, VFDOUT, VFCLK, VFBLANK	V <sub>OH</sub>	I <sub>SOURCE</sub> = 10mA	V+ - 0.6			V
Output Low-Voltage PHASE1, PHASE2, PORT0, PORT1, PUMP, VFLOAD, VFDOUT, VFCLK, VFBLANK	V <sub>OL</sub>	I <sub>SINK</sub> = 10mA			0.4V	V
Output Short-Circuit Source Current PHASE1, PHASE2, PORT0, PORT1, PUMP, VFLOAD, VFDOUT, VFCLK, VFBLANK	I <sub>OHSC</sub>	Output programmed high, output short circuit to GND (Note 2)		62	125	mA
Output Short-Circuit Sink Current PHASE1, PHASE2, PORT0, PORT1, PUMP, VFLOAD, VFDOUT, VFCLK, VFBLANK	I <sub>OLSC</sub>	Output programmed low, output short circuit to V+ (Note 2)		72	125	mA
<b>I<sup>2</sup>C TIMING CHARACTERISTICS</b> (Figure 6)						
Serial Clock Frequency	f <sub>SCL</sub>				400	kHz
Bus Free Time Between a STOP and a START Condition	t <sub>BUF</sub>		1.3			μs
Hold Time (Repeated) START Condition	t <sub>HD, STA</sub>		0.6			μs
Repeated START Condition Setup Time	t <sub>SU, STA</sub>		0.6			μs
STOP Condition Setup Time	t <sub>SU, STO</sub>		0.6			μs
Data Hold Time	t <sub>HD, DAT</sub>	(Note 3)			0.9	μs
Data Setup Time	t <sub>SU, DAT</sub>		100			ns
SCL Clock Low Period	t <sub>LOW</sub>		1.3			μs
SCL Clock High Period	t <sub>HIGH</sub>		0.6			μs
Rise Time of Both SDA and SCL Signals, Receiving	t <sub>R</sub>	(Notes 2, 4)		20 + 0.1C <sub>B</sub>	300	ns
Fall Time of Both SDA and SCL Signals, Receiving	t <sub>F</sub>	(Notes 2, 4)		20 + 0.1C <sub>B</sub>	300	ns

# 2-Wire Interfaced, 5 × 7 Matrix Vacuum-Fluorescent Display Controller

## DC ELECTRICAL CHARACTERISTICS (continued)

(Typical operating circuit,  $V_+ = 2.7V$  to  $3.6V$ ,  $T_A = T_{MIN}$  to  $T_{MAX}$ , unless otherwise noted.) (Note 1)

PARAMETER	SYMBOL	CONDITIONS	MIN	TYP	MAX	UNITS
Fall Time of SDA Transmitting	$t_F$	(Notes 2, 5)		20 + 0.1 $C_B$	250	ns
Pulse Width of Spike Suppressed	$t_{SP}$	(Note 6)	0	50		ns
Capacitive Load for Each Bus Line	$C_B$	(Note 2)		400		pF
<b>VFD INTERFACE TIMING CHARACTERISTICS</b> (Figure 14)						
VFCLK Clock Period	$t_{VCP}$	(Note 2)	250		1050	ns
VFCLK Pulse Width High	$t_{VCH}$	(Note 2)	125			ns
VFCLK Pulse Width Low	$t_{VCL}$	(Note 2)	125			ns
VFCLK Rise to VFD Load Rise Hold Time	$t_{VCSH}$	(Note 2)	19			$\mu s$
VFDOU Setup Time	$t_{VDS}$	(Note 2)	50			ns
VFLOAD Pulse High	$t_{VCSW}$	(Note 2)	245			ns

**Note 1:** All parameters tested at  $T_A = +25^\circ C$ . Specifications over temperature are guaranteed by design.

**Note 2:** Guaranteed by design.

**Note 3:** A master device must provide a hold time of at least 300ns for the SDA signal (referred to  $V_{IL}$  of the SCL signal) in order to bridge the undefined region of SCL's falling edge.

**Note 4:**  $C_B$  = total capacitance of one bus line in pF.  $t_R$  and  $t_F$  measured between 0.3V+ and 0.7V+.

**Note 5:**  $I_{SINK} \leq 6mA$ .  $C_B$  = total capacitance of one bus line in pF.  $t_R$  and  $t_F$  measured between 0.3V+ and 0.7V+.

**Note 6:** Input filters on the SDA and SCL inputs suppress noise spikes less than 50ns.

## Typical Operating Characteristics

(Typical Operating Circuit,  $V_+ = 3.3V$ ,  $T_A = +25^\circ C$ , unless otherwise noted.)

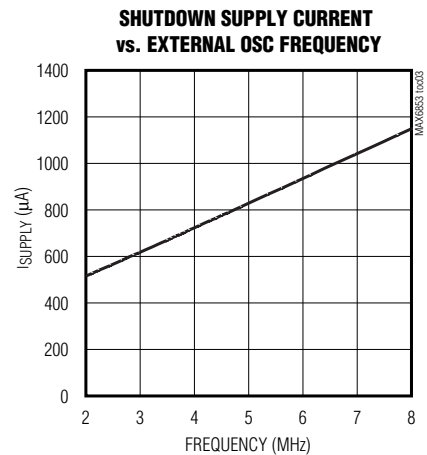
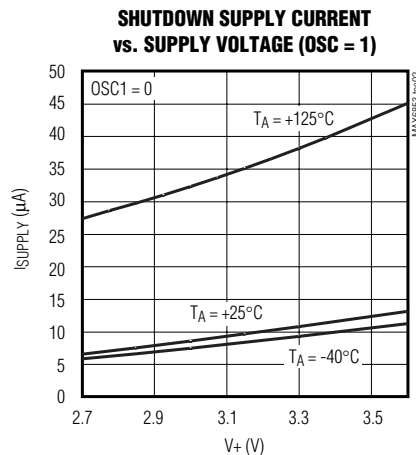
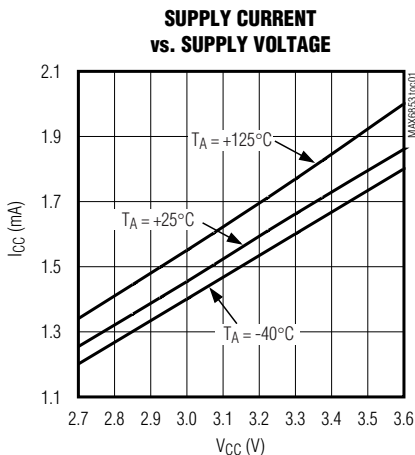

# 2-Wire Interfaced, 5 × 7 Matrix Vacuum-Fluorescent Display Controller

## Typical Operating Characteristics (continued)

(Typical Operating Circuit,  $V_+ = 3.3V$ ,  $T_A = +25^\circ C$ , unless otherwise noted.)

MAX6853

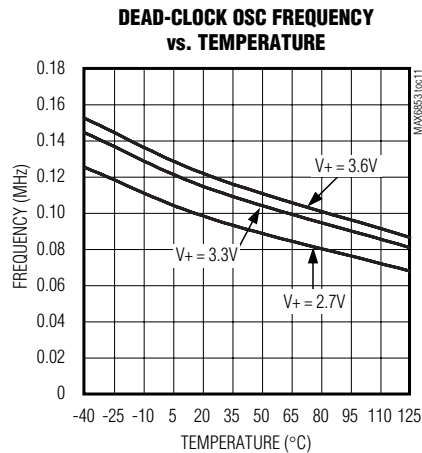
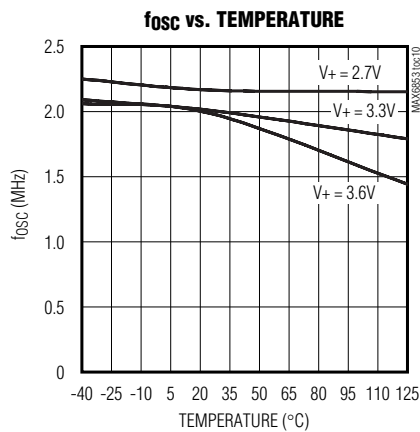
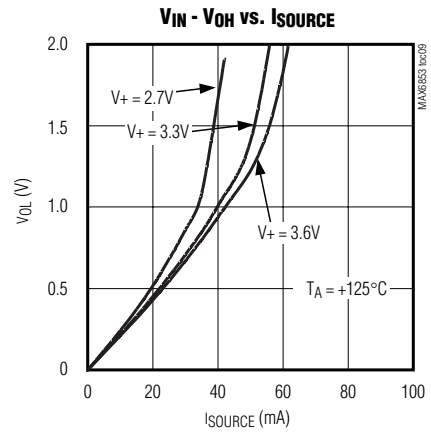
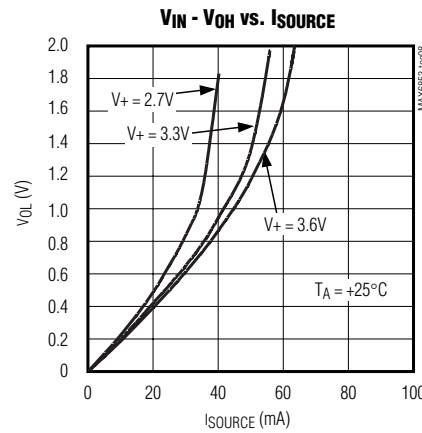
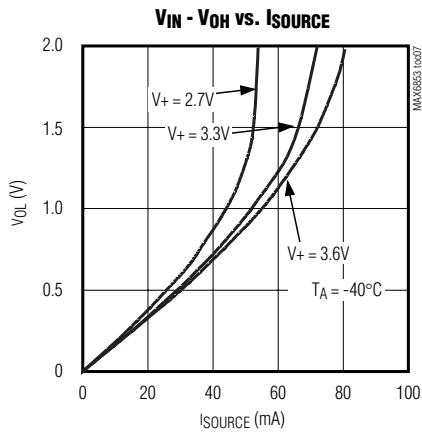
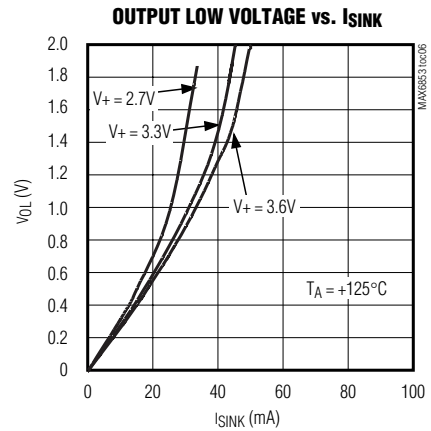
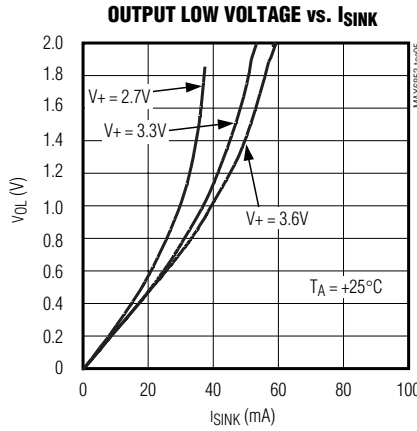
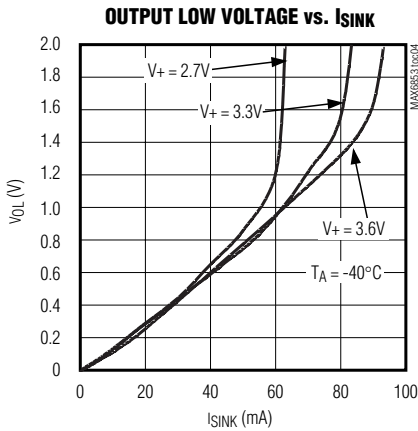

## 2-Wire Interfaced, 5 × 7 Matrix Vacuum-Fluorescent Display Controller

### Pin Description

PIN	NAME	FUNCTION
1	VFCLK	Serial-Clock Output to External Driver. Push-pull clock output to external display driver. On VFCLK's falling edge, data is clocked out of VFDOOUT.
2	VFDOOUT	Serial-Data Output to External Driver. Push-pull data output to external display driver.
3	VFLOAD	Serial-Load Output to External Driver. Push-pull load output to external display driver. Rising edge is used by external display driver to load serial data into display latch.
4	VFBLANK	Display Blanking Output to External Driver. Push-pull blanking output to external display driver used for PWM intensity control.
5	PUMP	PUMP General-Purpose Output. User-configurable push-pull logic output.
6	PHASE1	Filament Drive PHASE1 Output and General-Purpose Output. User-configurable push-pull logic output can also be used as a driver for external filament bridge drive.
7	PHASE2	Filament Drive PHASE2 Output and General-Purpose Output. User-configurable push-pull logic output can also be used as a driver for external filament bridge drive.
8	V+	Positive Supply Voltage. Bypass V+ to GND with a 0.1µF ceramic capacitor.
9	GND	Ground
10	PORT0	PORT0 General-Purpose Output. User-configurable push-pull logic output.
11	SCL	Serial-Clock Input
12	SDA	Serial-Data I/O
13	AD0	Address Input 0. Sets device slave address. Connect to either GND, V+, SCL, or SDA to give four logic combinations. See Table 7.
14	PORT1	PORT1 General-Purpose Output. User-configurable push-pull logic output.
15	OSC2	Multiplex Clock Input 2. Connect resistor R <sub>OSC</sub> from OSC2 to GND.
16	OSC1	Multiplex Clock Input 1. To use the internal oscillator, connect capacitor C <sub>OSC</sub> from OSC1 to GND. To use the external clock, drive OSC1 with a 2MHz to 8MHz CMOS clock.

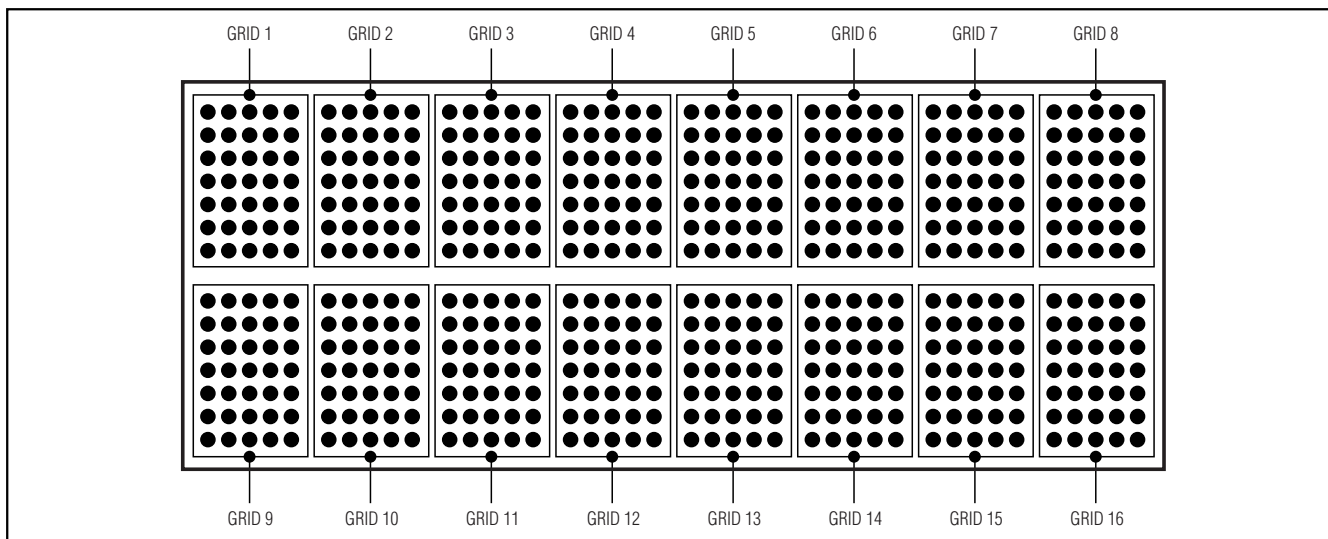

Figure 1. Example of a One-Digit-per-Grid Display

## 2-Wire Interfaced, 5 × 7 Matrix Vacuum-Fluorescent Display Controller

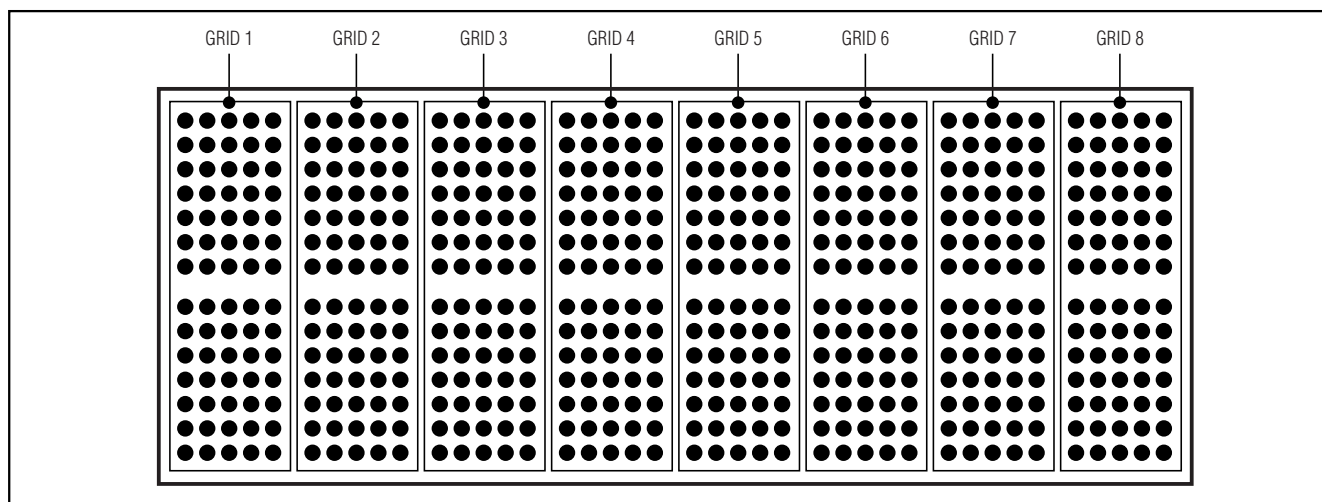

Figure 2. Example of a Two-Digits-per-Grid Display (8 Grids, 16 Digits)

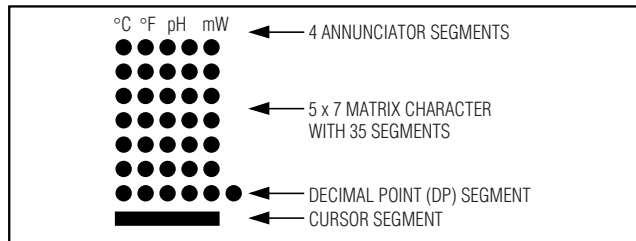

Figure 3. Digit Structure with 5 × 7 Matrix Character, DP Segment, Cursor Segment, Four Annunciators

### Detailed Description

#### Overview of the MAX6853

The MAX6853 VFD controller generates the multiplex timing for the following VFD display types:

- Multiplexed displays with one digit per grid, and up to 48 grids (in 48/1 mode). Each grid can contain one 5 × 7 matrix character, a DP segment, a cursor segment, and four extra annunciator segments (Figure 1).
- Multiplexed displays with two digits per grid, and up to 48 grids (in 96/2 mode). Each grid can contain two 5 × 7 matrix characters, two DP segments, and two cursor segments. No annunciator segments are supported (Figure 2).

Each digit can have a 5 × 7 matrix character, a DP segment, a cursor segment, and (for one-digit-per-grid displays only) four annunciators (Figure 3).

The 5 × 7 matrix character segments are not controlled directly, but use on-chip fonts that map the segments. The fonts comprise an ASCII 104-character fixed-font set, and 24 user-definable characters. The predefined characters follow the Arial font, with the addition of the following common symbols: £, €, ¥, °, μ, ±, ↑, and ↓. The 24 user-definable characters are uploaded by the user into on-chip RAM through the serial interface and are lost when the device is powered down. As well as custom 5 × 7 characters, the user-definable fonts can control up to 35 custom segments, bar graphs, or graphics.

Annunciator segments have individual, independent control, so any combination of annunciators can be lit. Annunciators can be off, lit, or blink either in phase or out of phase with the cursor. The blink-speed control is software selectable to be one or two blinks per second (OSC = 4MHz).

DP segments can be lit or off, but have no blink control. A DP segment is set by the same command that writes the digit's 5 × 7 matrix character.

The cursor segment is controlled differently. A single register selects one digit's cursor from the entire display, and that can be lit either continuously or blinking. All the other digits' cursors are off.

The designations of DP, cursor, and annunciator are interchangeable. For example, consider an application requiring only one DP lit at a time, but the DP needs to

## 2-Wire Interfaced, 5 × 7 Matrix Vacuum-Fluorescent Display Controller

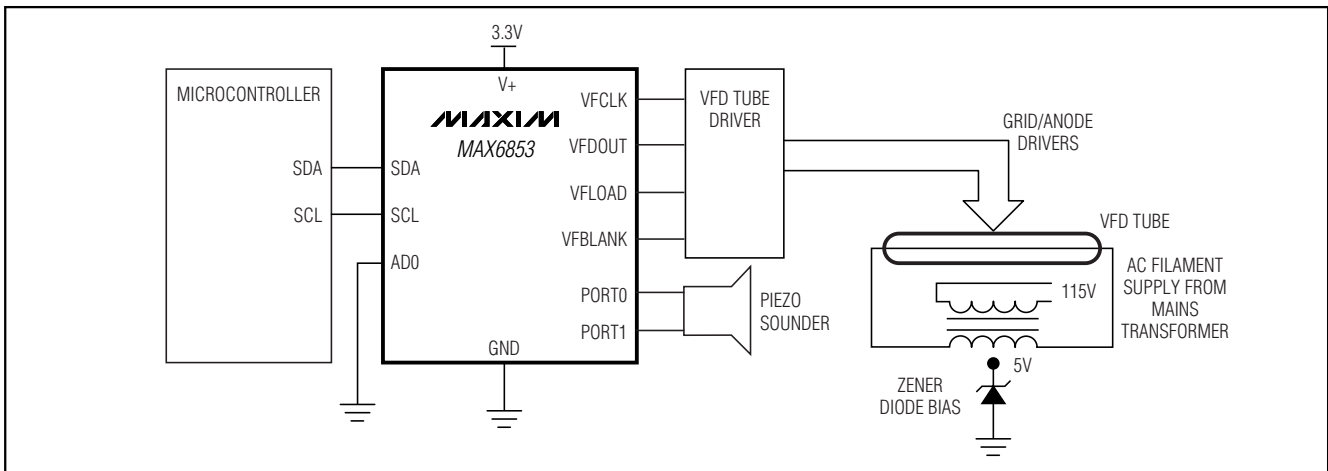

Figure 4. Connection of the MAX6853 to VFD Driver and VFD Tube

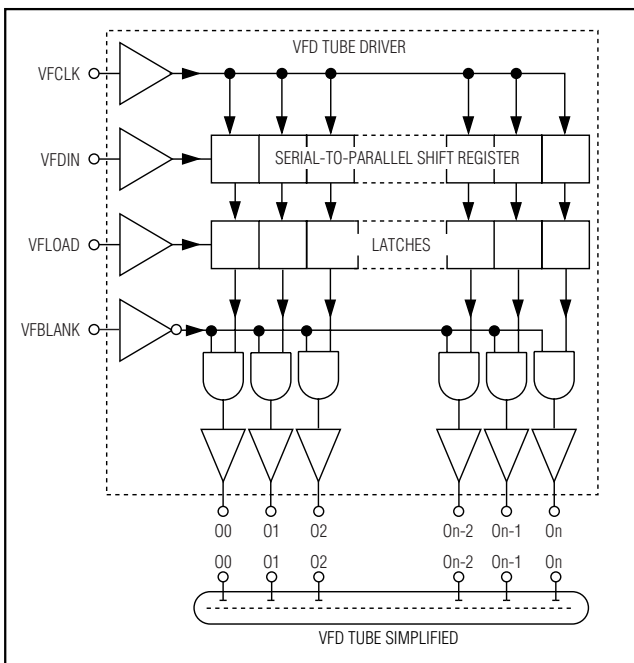

Figure 5. Block Diagram of VFD Tube Driver and VFD Tube

blink. The DP function does not have blink capability. Instead, the DP segments on the display are routed (using the output map) to the cursor function. In this case, the DP segments are controlled using the cursor register.

The output of the controller is a 4-wire serial stream that interfaces to industry-standard, shift-register, high-voltage grid/anode VFD tube drivers (Figure 4). This inter-

face uses three outputs to transfer and latch grid and anode data into the tube drivers, and a fourth output that enables/disables the tube driver outputs (Figure 5). The enable/disable control is modulated by the MAX6853 for both PWM intensity control and interdigit blanking, and disables the tube driver in shutdown. The controller multiplexes the display by enabling each grid of the VFD in turn for 100µs (OSC = 4MHz) with the correct segment (anode) data. The data for the next grid is transferred to the tube drivers during the display time of the current grid.

The controller uses an internal output map to match any tube-driver's shift-register grid/anode order, and is therefore compatible with all VFD internal chip-in-glass or external tube drivers.

The MAX6853 provides five high-current output ports, which can be configured for a variety of functions:

The PUMP output can be configured as either an 80kHz (OSC = 4MHz) clock intended for DC-to-DC converter use or a general-purpose logic output.

The PHASE1 and PHASE2 outputs can be individually configured as either 10kHz PWM outputs (OSC = 4MHz) intended for filament driving, blink status outputs, or general-purpose logic outputs.

The PORT0 and PORT1 outputs can be individually configured as either 625Hz, 1250Hz, or 2500Hz clocks (OSC = 4MHz) intended for buzzer driving, blink or shutdown status outputs, or general-purpose logic outputs.

### Display Modes

The MAX6853 has two display modes (Table 1), selected by the M bit in the configuration register (Table 23). The display modes trade the maximum allowable num-

## 2-Wire Interfaced, 5 × 7 Matrix Vacuum-Fluorescent Display Controller

**Table 1. Display Modes**

DISPLAY MODE	MAXIMUM NO. OF DIGITS	MAXIMUM NO. OF ANNUNCIATORS	MAXIMUM NO. OF GRIDS	DIGITS COVERED BY EACH GRID
48/1 mode	48 digits, each with a DP segment and a cursor segment	4 per digit	48 grids	1 digit per grid
96/2 mode	96 digits, each with a DP segment and a cursor segment	None		2 digits per grid

**Table 2. Register Address Map**

REGISTER	COMMAND ADDRESS								HEX CODE
	D15	D14	D13	D12	D11	D10	D9	D8	
No-op	R/W	0	0	0	0	0	0	0	0x00
VFBLANK polarity	R/W	0	0	0	0	0	0	1	0x01
Intensity	R/W	0	0	0	0	0	1	0	0x02
Grids	R/W	0	0	0	0	0	1	1	0x03
Configuration	R/W	0	0	0	0	1	0	0	0x04
User-defined fonts	R/W	0	0	0	0	1	0	1	0x05
Output map	R/W	0	0	0	0	1	1	0	0x06
Display test and device ID	R/W	0	0	0	0	1	1	1	0x07
PUMP register	R/W	0	0	0	1	0	0	0	0x08
Filament duty cycle	R/W	0	0	0	1	0	0	1	0x09
PHASE1	R/W	0	0	0	1	0	1	0	0x0A
PHASE2	R/W	0	0	0	1	0	1	1	0x0B
PORT0	R/W	0	0	0	1	1	0	0	0x0C
PORT1	R/W	0	0	0	1	1	0	1	0x0D
Shift limit	R/W	0	0	0	1	1	1	0	0x0E
Cursor	R/W	0	0	0	1	1	1	1	0x0F
Factory reserved. <b>Do not write to register.</b>	X	0	0	1	0	0	0	0	0x10

ber of digits (96/2 mode) against the availability of annunciator segments (48/1 mode). Table 2 is the register address map.

### Initial Power-Up

Initial power-up resets all control registers, clears display segment and annunciator data, sets intensity to minimum, and enables shutdown. (Table 3).

### Character Registers

The MAX6853 uses 48 character registers (48/1 mode) (Table 4) or 96 character registers (96/2 mode) (Table 5) to store the 5 × 7 characters (Table 6). Each digit is represented by 1 byte of memory. The data in the character registers does not control the character segments directly. Instead, the register data is used to address a character generator, which stores the data of the 128-character font (Table 9). The lower 7 bits of the character data (D6 to D0) select a character from the font

table. The most significant bit (MSB) of the register data (D7) controls the DP segment of the digit; it is set to light the DP, cleared to leave it unlit.

The character registers address maps are shown in Table 4 (48/1 mode) and Table 5 (96/2 mode).

In 48/1 mode, the character registers use a single address range 0x20 to {0x20 + g}, where g is the value in the grids register (Table 25). The 48/1 mode upper address limit, when g is 0x2F, is therefore 0x4F. The address range 0x50 to 0x7F is used for annunciator data in 48/1 mode.

In 96/2 mode, the character registers use two address ranges. The first row's address range is 0x20 to {0x20 + g}. The second row's address range is 0x50 to {0x50 + g}. Therefore, in 96/2 mode, the character registers are only one contiguous memory range when a 48-grid display is used.

## 2-Wire Interfaced, 5 × 7 Matrix Vacuum-Fluorescent Display Controller

### Character Generator Font Mapping

The font is a 5 x 7 matrix comprising 104 characters in ROM, and 24 user-definable characters. The selection from the total of 128 characters is represented by the lower 7 bits of the 8-bit digit registers. The MSB, shown as x in the ROM map (Table 9), controls the DP segment of the digit; it is set to light the DP, cleared to leave it unlit.

The character map follows the Arial font for 96 characters in the x010000 through x111111 range. The first 32 characters map the 24 user-definable positions (RAM00 to RAM23), plus eight extra common characters in ROM.

### User-Defined Fonts

The 24 user-definable characters are represented by 120 entries of 7-bit data, five entries per character, and are stored in the MAX6853's internal RAM.

The 120 user-definable font data entries are written and read through a single register, address 0x05. An autoincrementing font address pointer in the MAX6853 indirectly accesses the font data. The font address pointer can be written, setting one of 120 addresses between 0x00 and 0xF7, but cannot be read back. The font data is written to and read from the MAX6853 indirectly, using this font address pointer. Unused font locations can be used as general-purpose scratch RAM, noting that the font registers are only 7 bits wide, not 8.

**Table 3. Initial Power-Up Register Status**

REGISTER	POWER-UP CONDITION	COMMAND ADDRESS	REGISTER DATA							
			D7	D6	D5	D4	D3	D2	D1	D0
VFBLANK polarity	VFBLANK is high to disable the display	0x01	X	X	X	X	X	X	0	0
Intensity	1/16 (min on)	0x02	X	X	X	X	0	0	0	0
Grids	Display has 1 grid	0x03	X	X	0	0	0	0	0	0
Configuration	Shutdown enabled, configuration unlocked	0x04	1	0	0	0	X	0	0	0
User-defined font address pointer	Address 0x80; pointing to the first user-defined font location	0x05	1	0	0	0	0	0	0	0
User-defined fonts	All 24 characters blank	—	0	0	0	0	0	0	0	0
Output map pointer	Pointing to first entry address	0x06	1	0	0	0	0	0	0	0
Output map data	Predefined for 40-digit display	—	See Table 30 for power-up patterns.							
Display test	Normal operation	0x07	0	0	0	0	0	1	1	0
PUMP	General-purpose output, logic	0x08	0	0	0	0	0	0	0	0
Filament duty cycle	Minimum duty cycle	0x09	0	0	0	0	0	0	0	1
PHASE1	General-purpose output, logic	0x0A	0	0	0	0	0	0	0	0
PHASE2	General-purpose output, logic	0x0B	0	0	0	0	0	0	0	0
PORT0	General-purpose output, logic	0x0C	0	0	0	0	0	0	0	0
PORT1	General-purpose output, logic	0x0D	0	0	0	0	0	0	0	1
Shift limit	2 output bits	0x0E	X	0	0	0	0	0	0	1
Cursor	Off	0x0F	0	1	1	0	0	0	0	0
Character and annunciator data	Clear	0x20	0	0	0	0	0	0	0	0
<b>UP TO</b>	—	<b>UP TO</b>	—	—	—	—	—	—	—	—
Character and annunciator data	Clear	0x7F	0	0	0	0	0	0	0	0

## 2-Wire Interfaced, 5 × 7 Matrix Vacuum-Fluorescent Display Controller

**Table 4. Character and Annunciator Register Address Map in 48/1 Mode**

REGISTER	COMMAND ADDRESS								HEX CODE
	D15	D14	D13	D12	D11	D10	D9	D8	
Digit 0 5 × 7 matrix character	0	0	1	0	0	0	0	0	0x20
Digit 1 5 × 7 matrix character	0	0	1	0	0	0	0	1	0x21
Digit 2 5 × 7 matrix character	0	0	1	0	0	0	1	0	0x22
<b>UP TO</b>	—	—	—	—	—	—	—	—	—
Digit 4 5 × 7 matrix character	0	1	0	0	1	1	0	1	0x4D
Digit 46 5 × 7 matrix character	0	1	0	0	1	1	1	0	0x4E
Digit 47 5 × 7 matrix character	0	1	0	0	1	1	1	1	0x4F
Digit 0 annunciators	0	1	0	1	0	0	0	0	0x50
Digit 1 annunciators	0	1	0	1	0	0	0	1	0x51
Digit 2 annunciators	0	1	0	1	0	0	1	0	0x52
<b>UP TO</b>	—	—	—	—	—	—	—	—	—
Digit 45 annunciators	0	1	1	1	1	1	0	1	0x7D
Digit 46 annunciators	0	1	1	1	1	1	1	0	0x7E
Digit 47 annunciators	0	1	1	1	1	1	1	1	0x7F

Table 10 shows how to use the single user-defined font register 0x05 to set the font address pointer, write font data, and read font data. A read action always returns font data from the font address pointer position. A write action sets the 7-bit font address pointer if the MSB is set, or writes 7-bit font data to the font address pointer position if the MSB is clear.

The font address pointer autoincrements after a valid access to the user-definable font data. Auto-incrementing allows the 120-font data entries to be written and read back very quickly because the font pointer address need only be set once. After the last data location 0xF7 has been written, further font data entries are ignored until the font address pointer is reset. If the font address pointer is set to an out-of-range address by writing data in the 0xF8 to 0xFF range, then address 0x80 is set instead (Table 11).

Table 12 shows the user-definable font pointer base addresses.

Table 13 shows an example of data (characters 0, 1, and 2) being stored in the first three user-defined font locations, illustrating the orientation of the data bits.

Table 14 shows the six sequential write commands required to set a MAX6853's font character RAM02 with the data to display character 2 given in Table 9.

### Cursor Register

The cursor register controls the behavior of the cursor segments (Table 15). The MAX6853 controls 48 cursors in 48/1 mode, and 96 cursors in 96/2 mode. The cursor

register selects one digit's cursor to be lit either continuously or blinking. All the other digits' cursors are off.

The 7 least significant bits (LSBs) of the cursor register identify the cursor position. The MSB is clear for the cursor to be on continuously, and set for the cursor to be lit only during the first half of each blink period.

The valid cursor position address range is contiguous: 0 to 47 (0x00 to 0x2F) for the first digit row, and 48 to 95 (0x30 to 0x5F) for the last digit row. If the cursor register is programmed with an out-of-range value of 95 to 127 (0x60 to 0x7F), then all cursors are off.

### Annunciator Registers

The annunciator registers are organized in bytes, with each segment of each grid being represented by 2 bits. Thus, the four annunciators segments allowed for each grid are represented by exactly 1 byte (Table 16). Annunciators are only available in 48/1 mode. The annunciator address map is shown in Table 4.

### Configuration Register

The configuration register is used to enter and exit shutdown, lock the key VFD configuration settings, select the blink rate, globally clear the digit and annunciator data, reset the blink timing, and select between 48/1 and 96/2 display modes (Table 17).

### Shutdown Mode (S Data Bit D0) Format

The S bit in the configuration register selects shutdown or normal operation (Table 18). The display driver can be programmed while in shutdown mode, and shut-

## 2-Wire Interfaced, 5 × 7 Matrix Vacuum-Fluorescent Display Controller

**Table 5. Character Register Address Map in 96/2 Mode**

REGISTER	COMMAND ADDRESS								HEX CODE
	D15	D14	D13	D12	D11	D10	D9	D8	
Digit 0 5 x 7 matrix character, 1st row	0	0	1	0	0	0	0	0	0x20
Digit 1 5 x 7 matrix character, 1st row	0	0	1	0	0	0	0	1	0x21
Digit 2 5 x 7 matrix character, 1st row	0	0	1	0	0	0	1	0	0x22
<b>UP TO</b>	—	—	—	—	—	—	—	—	—
Digit 45 5 x 7 matrix character, 1st row	0	1	0	0	1	1	0	1	0x4D
Digit 46 5 x 7 matrix character, 1st row	0	1	0	0	1	1	1	0	0x4E
Digit 47 5 x 7 matrix character, 1st row	0	1	0	0	1	1	1	1	0x4F
Digit 0 5 x 7 matrix character, 2nd row	0	1	0	1	0	0	0	0	0x50
Digit 1 5 x 7 matrix character, 2nd row	0	1	0	1	0	0	0	1	0x51
Digit 2 5 x 7 matrix character, 2nd row	0	1	0	1	0	0	1	0	0x52
<b>UP TO</b>	—	—	—	—	—	—	—	—	—
Digit 45 5 x 7 matrix character, 2nd row	0	1	1	1	1	1	0	1	0x7D
Digit 46 5 x 7 matrix character, 2nd row	0	1	1	1	1	1	1	0	0x7E
Digit 47 5 x 7 matrix character, 2nd row	0	1	1	1	1	1	1	1	0x7F

**Table 6. Character Registers Format**

MODE	COMMAND ADDRESS	REGISTER DATA								
		D7	D6	D5	D4	D3	D2	D1	D0	
Writing character data to use font map data with DP segment <b>unlit</b>	0x20 to 0x4F (48/1 mode) 0x20 to 0x7F (96/2 mode)	0	Bits D6 to D0 select font characters 0 to 127							
Writing character data to use font map data with DP segment <b>lit</b>	0x20 to 0x4F (48/1 mode) 0x20 to 0x7F (96/2 mode)	1								

down mode is overridden when in display test mode. For normal operation, set S bit to 1.

When the MAX6853 is in shutdown mode, the multiplex oscillator is halted at the end of the current 100µs multiplex period (OSC = 4MHz), and the VFBLANK output is used to disable the VFD tube driver. Data in the digit and other control registers remains unaltered.

If the PUMP output is configured as a square-wave clock, then the PUMP output is forced low for the duration of shutdown, and the square-wave clock restored when the MAX6853 comes out of shutdown.

If the PHASE1 output or PHASE2 output is configured as a filament driver, then that output is forced low for the duration of shutdown and the filament drive waveforms restored when the MAX6853 comes out of shutdown.

When the MAX6853 comes out of shutdown, the external VFD tube driver is presumed to contain invalid data. The VFBLANK output is used to disable the VFD tube driver for the first multiplex cycle after exiting shutdown,

clearing any invalid data. The next multiplex cycle uses newly sent valid data.

### **Configuration Lock (L Data Bit D1) Format**

The configuration lock register is a safety feature to reduce the risk of the VFD configuration settings being inadvertently changed due to spurious writes if software fails. When set, the shift-limit register (0x0E), grids register (0x03), and output map data (0x06) can be read but cannot be written. The output map data pointer itself may be written in order to allow the output map data to be read back (Table 19).

### **Blink Rate Selection (B Data Bit D2) Format**

The B bit in the configuration register selects the blink rate of the cursor and annunciator segments. This is the speed that the segments blink on and off when blinking is selected for these segments. The frequency of the multiplex clock OSC and the setting of the B bit (Table 20) determine the blink rate.

## 2-Wire Interfaced, 5 × 7 Matrix Vacuum-Fluorescent Display Controller

### Global Blink Timing Synchronization (T Data Bit D4) Format

Setting the T bit in multiple MAX6853s at the same time (or in quick succession) synchronizes the blink timing across all the devices (Table 21). The display multiplexing sequence is also reset, which can give rise to a one-time display flicker when the register is written.

### Global Clear Digit Data (R Data Bit D5) Format

When the R bit (Table 22) is set, the segment and annunciator data are cleared.

### Display Mode (M Data Bit D6) Format

The M bit (Table 23) selects the display modes (Table 1). The display modes trade the maximum allowable number of digits (mode 96/2) against the availability of annunciator segments (mode 48/1).

### Blink Phase Readback (P Data Bit D7) Format

When the configuration register is read, the P bit reflects the blink phase at that time (Table 24).

## Serial Interface

### Serial Addressing

The MAX6853 operates as a slave that sends and receives data through an I<sup>2</sup>C-compatible 2-wire interface. The interface uses a serial data line (SDA) and a serial clock line (SCL) to achieve bidirectional communication between master(s) and slave(s). A master (typically a microcontroller) initiates all data transfers to and from the MAX6853, and generates the SCL clock that synchronizes the data transfer (Figure 6).

The MAX6853 SDA line operates as both an input and an open-drain output. A pullup resistor, typically 4.7kΩ, is required on the SDA. The MAX6853 SCL line operates only as an input. A pullup resistor, typically 4.7kΩ, is required on SCL if there are multiple masters on the 2-wire interface, or if the master in a single-master system has an open-drain SCL output.

Each transmission consists of a START condition (Figure 7) sent by a master, followed by the MAX6853 7-bit slave address plus R/W bit (Figure 10), a register address byte, 1 or more data bytes, and finally a STOP condition (Figure 7).

### Start and Stop Conditions

Both SCL and SDA remain high when the interface is not busy. A master signals the beginning of a transmission with a START (S) condition by transitioning SDA from high to low while SCL is high. When the master has finished communicating with the slave, it issues a STOP (P) condition by transitioning the SDA from low to high while SCL is high. The bus is then free for another transmission (Figure 7).

### Bit Transfer

One data bit is transferred during each clock pulse. The data on the SDA line must remain stable while SCL is high (Figure 8).

### Acknowledge

The acknowledge bit is a clocked 9th bit that the recipient uses to handshake receipt of each byte of data (Figure 9). Thus, each byte transferred effectively requires 9 bits. The master generates the 9th clock pulse, and the recipient pulls down SDA during the acknowledge clock pulse, such that the SDA line is stable low during the high period of the clock pulse. When the master is transmitting to the MAX6853, the MAX6853 generates the acknowledge bit because the MAX6853 is the recipient. When the MAX6853 is transmitting to the master, the master generates the acknowledge bit because the master is the recipient. In this case, the master acknowledges all bytes received from the MAX6853 except for the last byte required, after which the master issues a STOP condition to signify end of transmission.

### Slave Address

The MAX6853 has a 7-bit-long slave address (Figure 10). The eighth bit following the 7-bit slave address is the R/W bit. Set it low for a write command and high for a read command.

The first 5 bits (MSBs) of the MAX6853 slave address are always 11101. Slave address bits A1 and A0 are selected by the address input pins AD0. This input may be connected to GND, V+, SDA, or SCL. The MAX6853 has four possible slave addresses (Table 7) and therefore a maximum of four MAX6853 devices may share the same interface.

### Message Format for Writing

A write to the MAX6853 comprises the transmission of the MAX6853's slave address with the R/W bit set to zero, followed by at least 1 byte of information. The first byte of information is the command byte, which determines which register of the MAX6853 is to be written by the next byte, if received. If a STOP condition is detected after the command byte is received, then the MAX6853 takes no further action (Figure 11) beyond storing the command byte.

Any bytes received after the command byte are data bytes. The first data byte goes into the internal register of the MAX6853 selected by the command byte (Figure 12).

If multiple data bytes are transmitted before a STOP condition is detected, these bytes are generally stored in subsequent MAX6853 internal registers because the

# 2-Wire Interfaced, 5 × 7 Matrix Vacuum-Fluorescent Display Controller

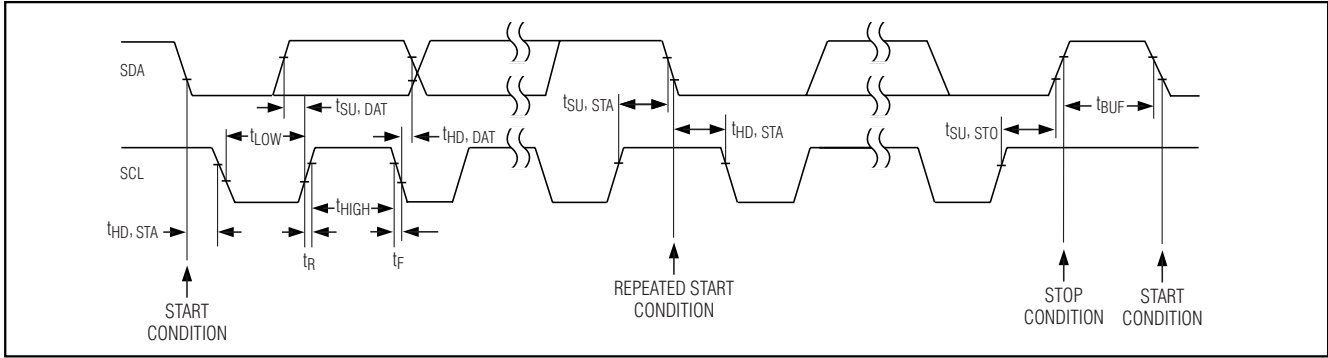

Figure 6. 2-Wire Serial Interface Timing Details

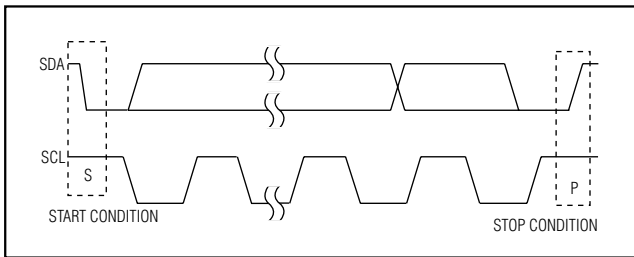

Figure 7. Start and Stop Conditions

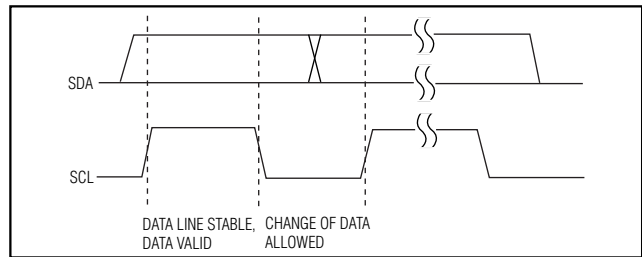

Figure 8. Bit Transfer

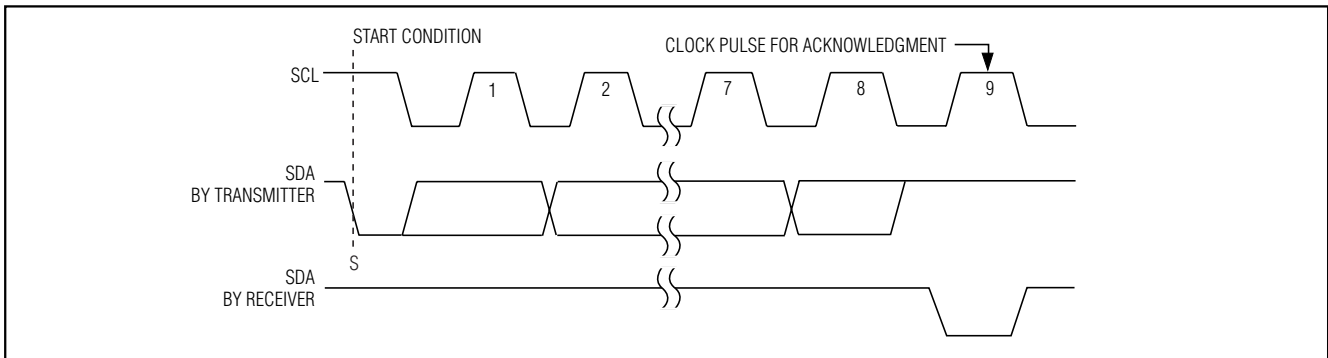

Figure 9. Acknowledge

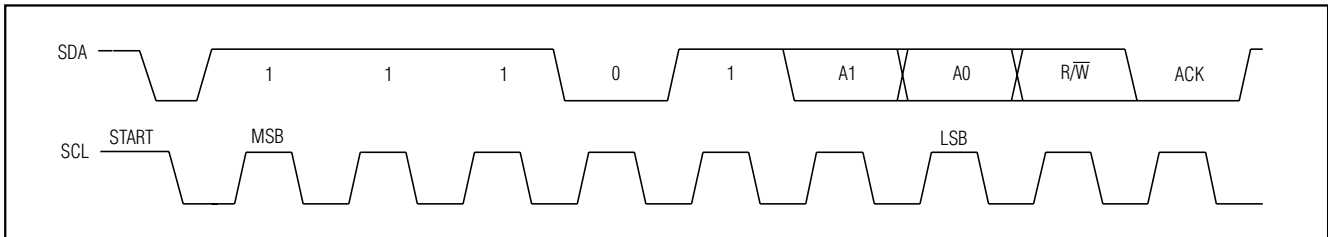

Figure 10. Slave Address

## 2-Wire Interfaced, 5 × 7 Matrix Vacuum-Fluorescent Display Controller

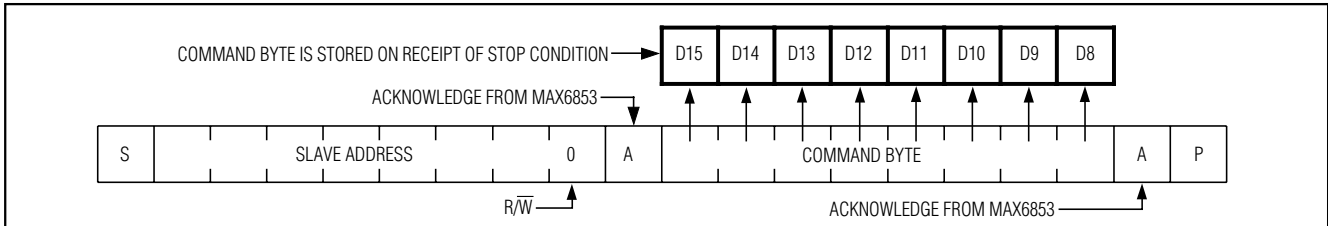

Figure 11. Command Byte Received

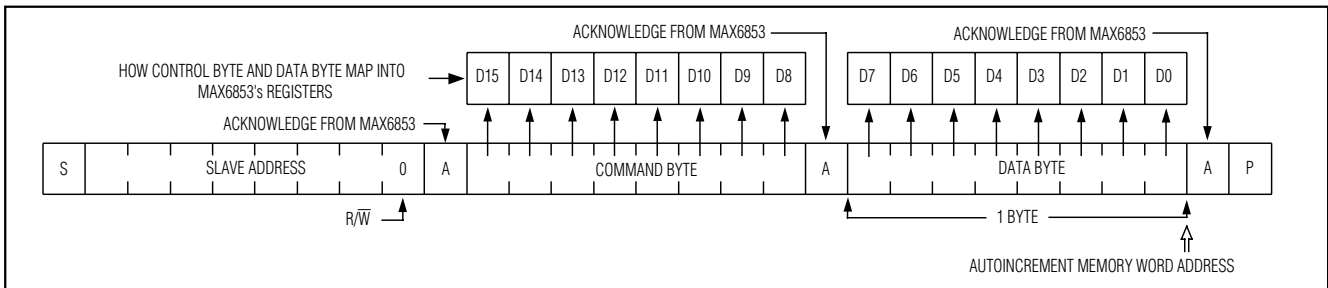

Figure 12. Command and Single Data Byte Received

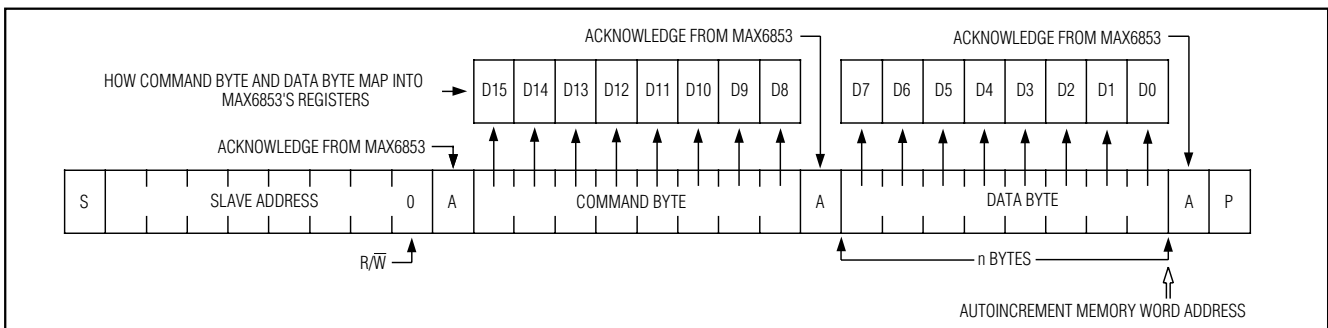

Figure 13. n Data Bytes Received

command byte address generally autoincrements (Table 8) (Figure 13).

### Message Format for Reading

The MAX6853 is read using the MAX6853's internally stored command byte as address pointer, the same way the stored command byte is used as address pointer for a write. The pointer generally autoincrements after each data byte is read using the same rules as for a write (Table 8). Thus, a read is initiated by first configuring the MAX6853's command byte by performing a write (Figure 11). The master can now read n consecutive bytes from the MAX6853, with the first data byte being read from the register addressed by the initialized command byte (Figure 13). When performing read-after-write verification, reset the command byte's address because the stored byte address generally is autoincremented after the write (Table 8).

### Operation with Multiple Masters

If the MAX6853 is operated on a 2-wire interface with multiple masters, a master reading the MAX6853 should use a repeated start between the write, which sets the MAX6853's address pointer, and the read(s) that takes the data from the location(s). This is because it is possible for master 2 to take over the bus after master

Table 7. MAX6853 Address Map

PIN	DEVICE ADDRESS						
	A6	A5	A4	A3	A2	A1	A0
GND	1	1	1	0	1	0	0
V+	1	1	1	0	1	0	1
SDA	1	1	1	0	1	1	0
SCL	1	1	1	0	1	1	1

## 2-Wire Interfaced, 5 × 7 Matrix Vacuum-Fluorescent Display Controller

**Table 8. Command Address Autoincrement Rules**

COMMAND BYTE ADDRESS RANGE	AUTOINCREMENT BEHAVIOR
x0000000 to x0000100	Command byte address autoincrements after byte read or written.
x0000110	Command byte address remains at x0000110 after byte read or written, but the font output map address pointer autoincrements.
x0010000	Factory reserved; do not write to this register.
x0001111 to x1111110	Command byte address autoincrements after byte read or written.
x1111111	Command byte address remains at x1111111 after byte read or written.

1 has set up the MAX6853's address pointer but before master 1 has read the data. If master 2 subsequently changes the MAX6853's address pointer, then master 1's delayed read may be from an unexpected location.

### Command Address Autoincrementing

Address autoincrementing allows the MAX6853 to be configured with the shortest number of transmissions by minimizing the number of times the command byte needs to be sent. The command address or the font pointer address stored in the MAX6853 generally increments after each data byte is written or read (Table 8).

### VFD Driver Serial Interface

The VFD driver interface on the MAX6853 is a serial interface using three outputs, VFLOAD, VFCLK, and VFDOOUT (Figure 14) to drive industry-standard, shift-register, high-voltage grid/anode VFD tube drivers (Figures 3 and 4). The speed of VFCLK is 2MHz when OSC is 4MHz. The maximum speed of VFCLK is 4MHz when OSC is 8MHz. This interface transfers display data from the MAX6853 to the VFD tube driver. The serial interface bit stream output is programmable up to 122 bits, which are labeled DD0–DD121.

The functions of the three interface outputs are as follows: VFCLK is the serial clock output, which shifts data on its falling edge from the MAX6853's 122-bit output shift register to VFLOAD.

VFDOOUT is the serial data output. The data changes on VFCLK's falling edge, and is stable when it is sampled by the display driver on the rising edge of VFCLK.

VFLOAD is the latch-load output. VFLOAD is high to transfer data from the display tube driver's shift register to the display driver's output latch (transparent mode), and low to retain that data in the display driver's output latch.

A fourth output, VFBLANK, provides gating control of the tube driver. VFBLANK can be configured to be either high or low using the VBLANK polarity register (Table 27) to enable the VFD tube driver. In the default

condition, VFBLANK is high to disable the VFD tube driver, which is expected to force its driver outputs low to blank the display without altering the contents of its output latches. In the default condition, VFBLANK is low to enable its VFD tube driver outputs to follow the state of the VFD tube driver's output latches. The VFBLANK output is used for PWM intensity control and to disable the VFD tube driver in shutdown.

### Multiplex Architecture

The multiplex engine transmits grid and anode control data to the external VFD driver using the VFCLK, VFDOOUT, and VFLOAD. The number of data bits  $m$  transmitted is set by the user in the shift-limit register (Table 29). Figure 15 is the VFD multiplex timing diagram.

The essential rules for multiplex action are as follows:

- The external VFD driver's data latch contains the data for the current grid being displayed.
- The VFBLANK input is controlled to provide the PWM intensity control.
- The VFCLK and VFDOOUT outputs are used to fill the external VFD driver's shift register with the multiplex data for the next grid, during the multiplex timeslot for the current grid.
- The VFLOAD output loads the new grid-anode data pattern at the start of its multiplex cycle.

### Grids Register

The grids register sets how many grids are multiplexed from 1 to 48 (Table 25).

When the grids register is written, the external VFD tube driver is presumed to contain invalid data. The VFBLANK output disables the VFD tube driver for the first multiplex cycle after exiting shutdown, clearing any invalid data. The next multiplex cycle uses newly sent valid data. If the grids register is written with an out-of-range value of 0x30 to 0xFF, then the value 0x2F is stored instead.

# 2-Wire Interfaced, 5 × 7 Matrix Vacuum-Fluorescent Display Controller

MAX6853

## Intensity Register

Digital control of display brightness is provided by pulse-width modulation of the tube blanking time, which is controlled by the lower nibble of the intensity register (Table 26). The modulator scales the VFBLANK output in 15 steps from a minimum of 1/16 up to 15/16 of each grid's multiplex period (Figure 16). Figure 17 shows the modulator behavior when the VFBLANK polarity register is set to 0x00 (Table 27), so VFBLANK is high to disable (blank) the display.

The minimum off-time period of a 1/16 multiplex period (6.25µs with OSC = 4MHz) is always at the start of the multiplex cycle. This allows time for slow display drivers to turn off, and slow display phosphors time to decay between grids. Thus, image ghosting is avoided. If a display has very slow phosphor, double the allowed decay time by not using a 15/16 duty cycle.

## VFBLANK Polarity Register

The VFBLANK polarity register sets the active level of the VFBLANK output pin (Table 27).

## No-Op Register

A write to the no-op register is ignored.

## Display-Test and Device ID Register

Writing the display-test and device ID register switches the drivers between one of two modes: normal and display test. Display-test mode turns all segments and annunciators on and sets the duty cycle to 7/16 (half-power) (Table 28).

Reading the display-test and device ID register returns the MAX6853 device ID 0b0000 011 that identifies the driver type, plus the display-test status in the LSB.

## Output Shift-Limit Register

The output serial interface transfers display data from the MAX6853 to the display driver. The serial interface bit-stream output length is programmable up to 122 bits, which are labeled DD0–DD121. Set the number of bits with the shift-limit register, address 0x0E. If the shift-limit register is written with an out-of-range value 0x7A to 0xFF, then the value 0x79 is stored instead. Table 29 shows the shift-limit register.

## Output Map

The output map comprises 122 words of 7-bit RAM. The output map data should be written when the MAX6853 is configured after power-up. Table 30 shows the output map RAM codes.

Table 9. Character Map

MSB \ LSB	x000	x001	x010	x011	x100	x101	x110	x111
0000	RAM00	RAM16						
0001	RAM01	RAM17						
0010	RAM02	RAM18						
0011	RAM03	RAM19						
0100	RAM04	RAM20						
0101	RAM05	RAM21						
0110	RAM06	RAM22						
0111	RAM07	RAM23						
1000	RAM08							
1001	RAM09							
1010	RAM10							
1011	RAM11							
1100	RAM12							
1101	RAM13							
1110	RAM14							
1111	RAM15							

## 2-Wire Interfaced, 5 × 7 Matrix Vacuum-Fluorescent Display Controller

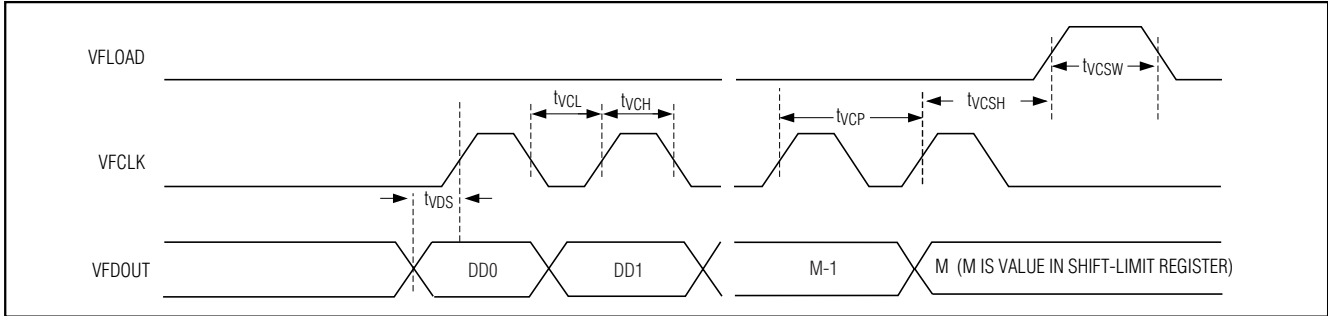

Figure 14. VFD Interface Timing Diagram

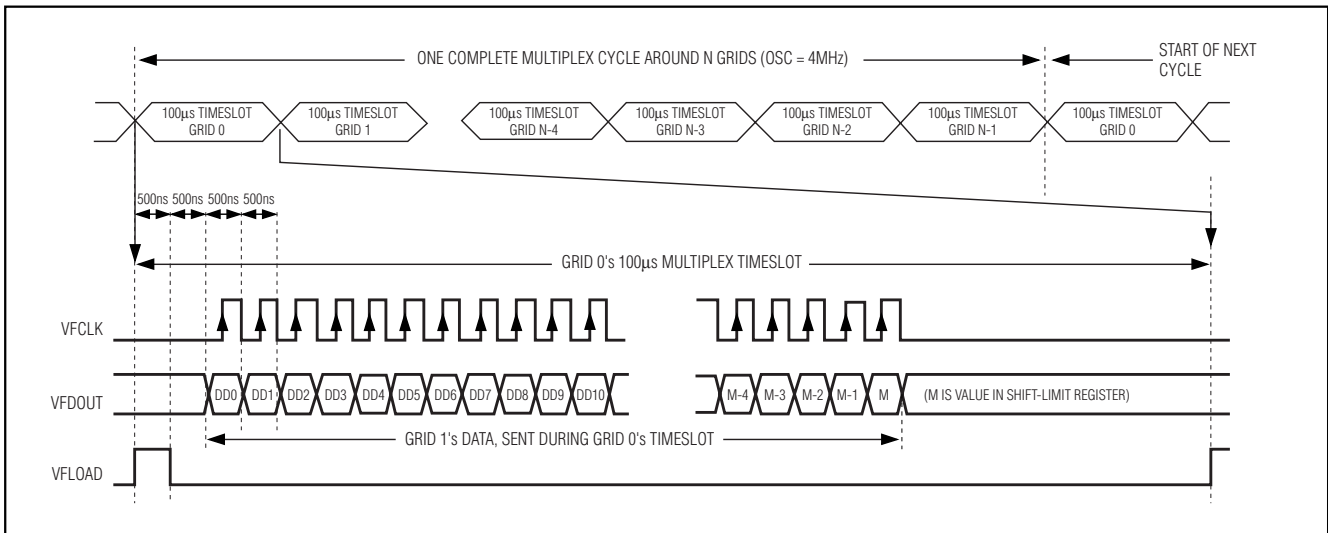

Figure 15. VFD Multiplex Timing Diagram

The output map is an indirect addressing reference table. It translates bit position in the output shift register (valid range: from zero to the value in shift-limit register 0x0E) to bit function. Any output shift-register bit position may be set to any grid, 5 x 7 matrix segment, DP segment, annunciator segment, or cursor segment.

The power-up default pattern for output map RAM maps a 40-digit, two-digits-per-grid display with DPs and cursors (Table 31).

Selecting an unused map RAM entry (126 or 127) for an output shift-register position always resets the corresponding output bit to low (segment or grid OFF).

When selecting an invalid map RAM entry (for example, codes 48 to 83 to select annunciators in 96/2 mode, which does not support annunciators), the corresponding output bit is always low (segment or grid OFF).

If the map RAM entry corresponds to a nonexistent font segment (no action in Table 30) when the digit data is processed through the character font, then the result again is zero (segment or grid OFF).

The output map data is indirectly accessed by an autoincrementing output map address pointer in the MAX6853 at address 0x06. The output map address pointer can be written (i.e., set to an address between 0x00 and 0x79) but cannot be read back. The output map data is written and read back through the output map address pointer.

Table 32 shows how to set the output map address pointer to a value within the acceptable range. Bit D7 is set to denote that the user is writing the output map address pointer. If the user attempts to set the output map address to one of the out-of-range addresses by writing data in range 0xFA to 0xFF, then address 0x00 is set instead.

## 2-Wire Interfaced, 5 × 7 Matrix Vacuum-Fluorescent Display Controller

**MAX6853**

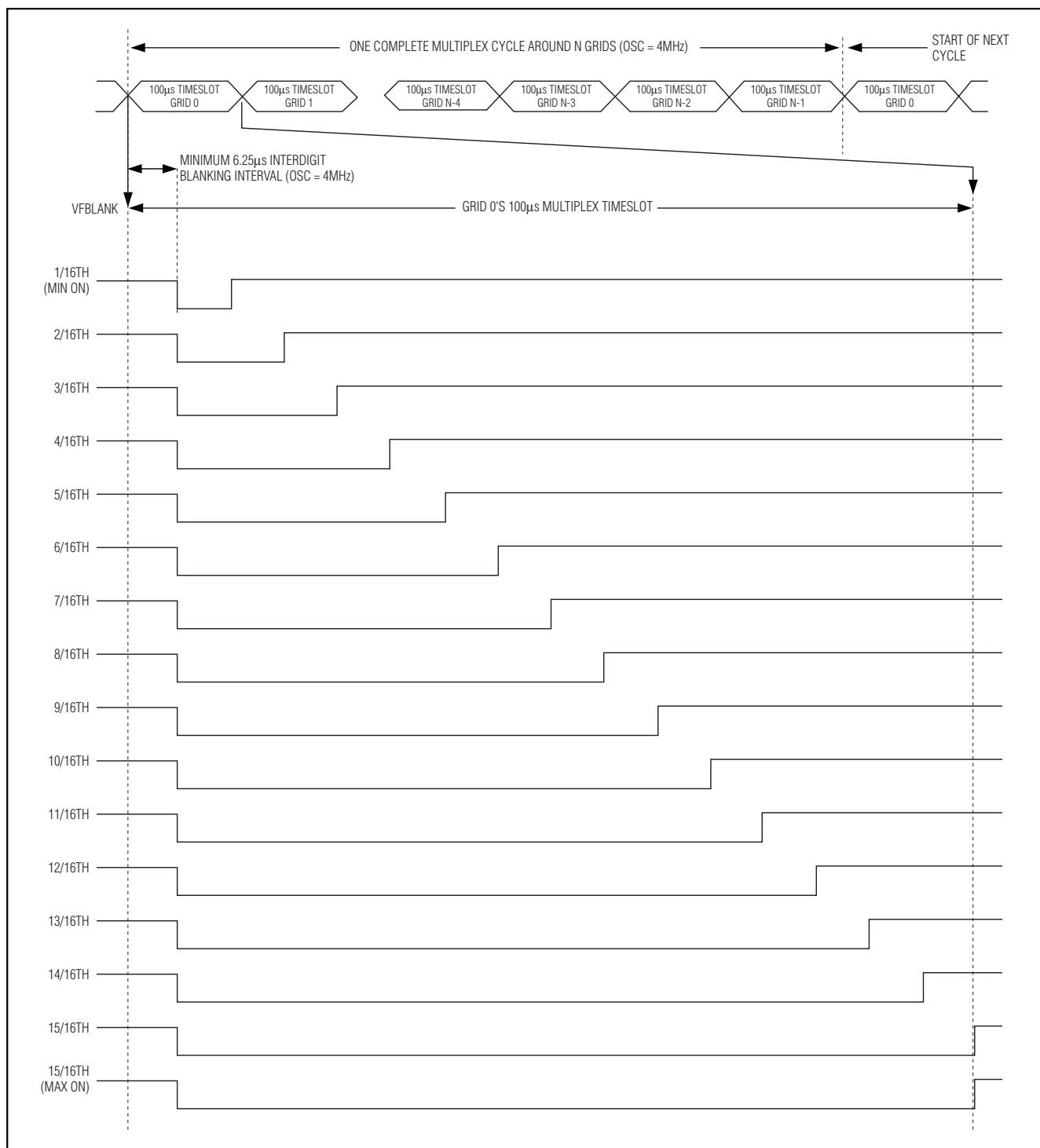

Figure 16. BLANK and Intensity Timing Diagram

# 2-Wire Interfaced, 5 × 7 Matrix Vacuum-Fluorescent Display Controller

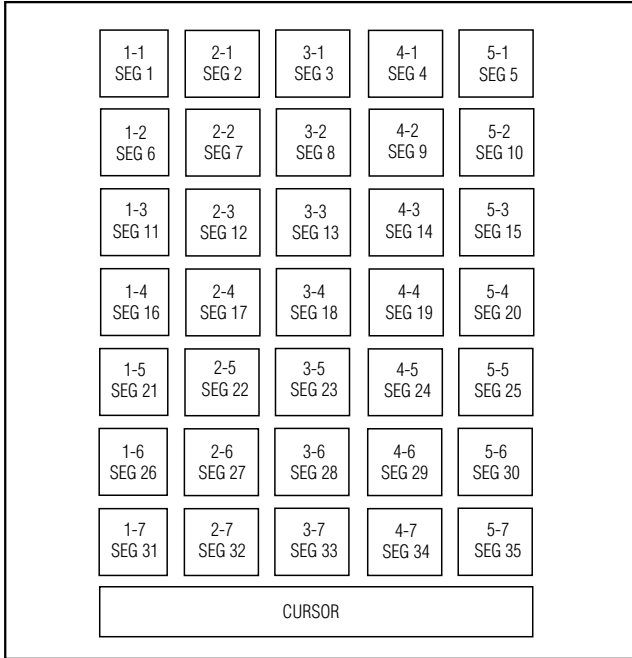

Figure 17. Relationship Between Segment Output and VFD Tube 5 × 7 Matrix Dots

After the last data location 0xF9 has been written, further output map data entries are ignored until the output map address pointer is reset.

The output map data can be written to the address set by the output map address pointer. Bit D7 is clear to denote that the user is writing actual output map data. The output map address pointer is autoincremented after the output map data has been written to the current location. If the user writes the output map data in the RAM order, then the output map address pointer need only be set once, or even not at all as the address is set to 0x00 as power-up default (Table 33).

The output map data can be read by reading address 0x86. The 7-bit output map data at the address set by the output map address pointer is read back, with the MSB clear. The output map address pointer is autoincremented after the output map data has been read from the current location, in the same way as for a write (Table 34).

### Filament Drive

The VFD filament is typically driven with an AC waveform, supplied by a center-tapped 50Hz or 60Hz power transformer as part of the system power supply. However, if the system has only DC supplies available,

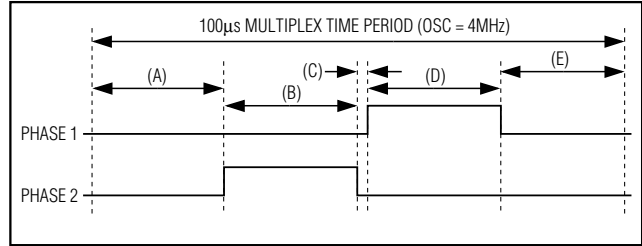

Figure 18. Filament Bridge Driver Timing Waveforms

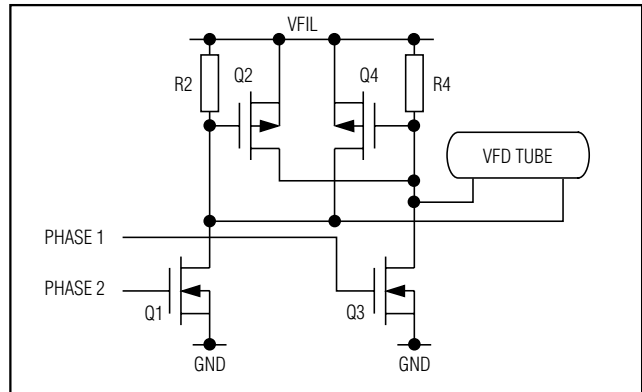

Figure 19. Filament Bridge Driver (MOSFET)

the filament must be powered by a DC-to-AC or DC-to-DC converter.

The MAX6853 can generate the waveforms on the PHASE1 and PHASE2 outputs to drive the VFD filament using a full bridge (push-pull drive). The PHASE1 and PHASE2 outputs can be used as general-purpose outputs if the filament drive is not required. The bridge drive transistors are external, but the waveforms are generated by the MAX6853.

The waveform generation uses PWM to set the effective RMS voltage across the filament, as a fraction of the external supply voltage (Figure 18) (Table 35). The filament switching frequency is synchronized to the multiplex scan clock, eliminating beating artifacts due to differing filament and multiplex frequencies.

The PWM duty cycle is controlled by the filament duty-cycle register (Table 36). The effective RMS voltage across the filament is given by the expression:

$$V_{RMS} = FilOn \times (V_{FIL} - V_{LO-BRIDGE} - V_{HI-BRIDGE}) / 200$$

or, rearranged:

$$Duty = 200 \times V_{RMS} / (V_{FIL} - V_{LO-BRIDGE} - V_{HI-BRIDGE})$$

where:

## 2-Wire Interfaced, 5 × 7 Matrix Vacuum-Fluorescent Display Controller

FilOn is the number to store in the filament duty-cycle register, address 0x09.

VFIL is the supply voltage to the filament driver bridge (V).

VRMS is the specified nominal filament supply voltage (V).

VLO-BRIDGE is the voltage drop across a low-side bridge driver (V).

VHI-BRIDGE is the voltage drop across a high-side bridge driver (V).

The minimum commutation time, shown at (C) in Figure 18, is set by  $(2/OSC)s$  (500ns when  $OSC = 4MHz$ ) to ensure that shoot-through currents cannot flow during phase reversal. Otherwise, the duty cycle of the bridge sets the RMS voltage across the filament. This technique provides a low-cost AC filament supply when using a regulated supply higher than the RMS voltage rating of the filament.

Figure 19 shows the external components required for the filament driver using a FET bridge.

### PHASE1 and PHASE2 Outputs

PHASE1 and PHASE2 can be individually programmed as one of four output types (Tables 37, 38).

When using the filament drive, first ensure that the filament duty-cycle register 0x09 is set to the correct value before configuring the PHASE1 and PHASE2 outputs to be filament drives. To stop the filament drive, program either PHASE1 or PHASE2 (or both) to be logic-low general-purpose outputs. Both PHASE1 and PHASE2 outputs come out of power-on-reset in logic-low condition.

### PORT0 and PORT1 Outputs

PORT0 and PORT1 can be individually programmed as one of eight output types (Tables 39, 40). The PORT1 choices are similar to the PORT0 choices, except that the last four items are invert logic. PORT0 output comes out of power-on-reset in logic-low condition, whereas PORT1 output initializes high.

The PORT0 and PORT1 shutdown outputs allow external hardware (for example, a DC-to-DC converter power supply for VFD) to be disabled by the MAX6853 when the MAX6853 is shut down.

The 625Hz, 1250Hz, and 2500Hz outputs can drive a piezo sounder either from PORT0 or PORT1 alone, or by both ports together as bridge drive. For bridge drive, the sounder is connected between PORT0 and PORT1, taking advantage of the PORT1 output being inverted with respect to PORT0. Select different frequencies for PORT0 and PORT1 to obtain a wider range of sounds when bridge drive is used.

### PUMP Output

Program the PUMP output as one of four output types (Table 41).

### Multiplex Clock and Blink Timing

The OSC1 and OSC2 inputs set the multiplex and blink timing for the display driver. Connect an external resistor from OSC2 to GND and an external capacitor  $C_{OSC}$  from OSC1 to GND to set the frequency of the internal RC oscillator. Alternatively, overdrive OSC1 with an external TTL or CMOS clock. Use an external clock ranging between 2MHz and 8MHz to drive OSC1 to produce an exact blink rate or multiplier period.

The multiplex clock frequency determines the multiplex scan rate and the blink timing. The display scan rate is  $\{OSC / 400 / (1 + \text{grids register value})\}$ . There are 400 OSC cycles per digit multiplex period. For example, with  $OSC = 4MHz$ , each display digit is enabled for 100 $\mu s$ . For a 40-grid display tube (grids register value = 39 or 0x27), the display scan rate is 250Hz.

The BLINK output is the selectable blink period clock. It is nominally 0.5Hz or 1Hz ( $OSC = 4MHz$ ). It is low during the first half of the blink period, and high during the second half. The PORT0 and PORT1 general-purpose outputs may be programmed to be BLINK output. Synchronize the BLINK timing if desired by setting the T bit in the configuration register (Table 21).

The RC oscillator uses an external resistor  $R_{OSC}$  and an external capacitor  $C_{OSC}$  to set the oscillator frequency.  $R_{OSC}$  connects from OSC2 to ground.  $C_{OSC}$  connects from OSC1 to ground. The following values of  $R_{OSC}$  and  $C_{OSC}$  set the oscillator to 4MHz, which makes the BLINK frequencies 0.5Hz and 1 Hz:

$$f_{OSC} = K_F / (R_{OSC} \times [C_{OSC} + C_{STRAY}]) \text{ MHz}$$

where:

$$K_F = 2320$$

$R_{OSC}$  = external resistor in k $\Omega$  (allowable range 8k $\Omega$  to 80k $\Omega$ )

$C_{OSC}$  = external capacitor in pF

$C_{STRAY}$  = stray capacitance from OSC1 to GND in pF, typically 2pF

For  $OSC = 4MHz$ ,  $R_{OSC}$  is 10k $\Omega$  and  $C_{OSC}$  is 56pF.

The effective value of  $C_{OSC}$  includes not only the actual external capacitor used, but also the stray capacitance from OSC1 to GND. This capacitance is usually in the 1pF to 5pF range, depending on the layout used.

The allowed range of  $f_{OSC}$  is 2MHz to 8MHz. If  $f_{OSC}$  is set too high, the internal oscillator can stop working. An internal fail-safe circuit monitors the multiplex clock and

## 2-Wire Interfaced, 5 × 7 Matrix Vacuum-Fluorescent Display Controller

detects a slow or nonworking multiplex clock. When a slow or nonworking multiplex clock is detected, an internal fail-safe oscillator generates a replacement clock of about 200kHz. This backup clock ensures that the VFD is not damaged by the multiplex operation halting inadvertently. The scan rate for 16 digits is about 15Hz in fail-safe mode, and the display flickers. A flickering display is a good indication that there is a problem with the multiplex clock.

### Power Supplies

The MAX6853 operates from a single 2.7V to 3.6V power supply. Bypass the power supply to GND with a 0.1μF capacitor as close to the device as possible. Add a bulk capacitor (such as a low-cost electrolytic 1μF to 22μF) if the MAX6853 is driving high current from any of the general-purpose output ports.

**Table 10. Memory Mapping of User-Defined Font Register 0x05**

COMMAND ADDRESS	REGISTER DATA	READ OR WRITE	FUNCTION
0x05	0x00–0x7F	Read	Read 7-bit user-definable font data entry from current font address. MSB of the register data is clear. Font address pointer is incremented after the read.
0x05	0x00–0x7F	Write	Write 7-bit user-definable font data entry to current font address. Font address pointer is incremented after the write.
0x05	0x80–0xFF	Write	Write font address pointer with the register data.

**Table 11. Font Pointer Address Behavior**

FONT POINTER ADDRESS	ACTION
0x80 to 0xF6	Valid range to set the font address pointer. Pointer autoincrements after a font data read or write, while pointer address remains in this range.
0xF7	Further font data is ignored after a font data read or write to this pointer address.
0xF8 to 0xFF	Invalid range to set the font address pointer. Pointer is set to 0x80.

## 2-Wire Interfaced, 5 × 7 Matrix Vacuum-Fluorescent Display Controller

**MAX6853**

**Table 12. User-Definable Font Pointer Base Address Table**

FONT CHARACTER	COMMAND ADDRESS	REGISTER DATA	REGISTER DATA							
			D7	D6	D5	D4	D3	D2	D1	D0
RAM00	0x05	0x80	1	0	0	0	0	0	0	0
RAM01	0x05	0x85	1	0	0	0	0	1	0	1
RAM02	0x05	0x8A	1	0	0	0	1	0	1	0
RAM03	0x05	0x8F	1	0	0	0	1	1	1	1
RAM04	0x05	0x94	1	0	0	1	0	1	0	0
RAM05	0x05	0x99	1	0	0	1	1	0	0	1
RAM06	0x05	0x9E	1	0	0	1	1	1	1	0
RAM07	0x05	0xA3	1	0	1	0	0	0	1	1
RAM08	0x05	0xA8	1	0	1	0	1	0	0	0
RAM09	0x05	0xAD	1	0	1	0	1	1	0	1
RAM10	0x05	0xB2	1	0	1	1	0	0	1	0
RAM11	0x05	0xB7	1	0	1	1	0	1	1	1
RAM12	0x05	0xBC	1	0	1	1	1	1	0	0
RAM13	0x05	0xC1	1	1	0	0	0	0	0	1
RAM14	0x05	0xC6	1	1	0	0	0	1	1	0
RAM15	0x05	0xCB	1	1	0	0	1	0	1	1
RAM16	0x05	0xD0	1	1	0	1	0	0	0	0
RAM17	0x05	0xD5	1	1	0	1	0	1	0	1
RAM18	0x05	0xDA	1	1	0	1	1	0	1	0
RAM19	0x05	0xDF	1	1	0	1	1	1	1	1
RAM20	0x05	0xE4	1	1	1	0	0	1	0	0
RAM21	0x05	0xE9	1	1	1	0	1	0	0	1
RAM22	0x05	0xEE	1	1	1	0	1	1	1	0
RAM23	0x05	0xF3	1	1	1	1	0	0	1	1

## 2-Wire Interfaced, 5 × 7 Matrix Vacuum-Fluorescent Display Controller

**Table 13. User-Definable Character Storage Example**

FONT CHARACTER	FONT ADDRESS POINTER	COMMAND ADDRESS	REGISTER DATA							
			D7	D6	D5	D4	D3	D2	D1	D0
RAM00	0x00	0x05	0	0	1	1	1	1	1	0
RAM00	0x01	0x05	0	1	0	1	0	0	0	1
RAM00	0x02	0x05	0	1	0	0	1	0	0	1
RAM00	0x03	0x05	0	1	0	0	0	1	0	1
RAM00	0x04	0x05	0	0	1	1	1	1	1	0
RAM01	0x05	0x05	0	0	0	0	0	0	0	0
RAM01	0x06	0x05	0	1	0	0	0	0	1	0
RAM01	0x07	0x05	0	1	1	1	1	1	1	1
RAM01	0x08	0x05	0	1	0	0	0	0	0	0
RAM01	0x09	0x05	0	0	0	0	0	0	0	0
RAM02	0x0A	0x05	0	1	0	0	0	0	1	0
RAM02	0x0B	0x05	0	1	1	0	0	0	0	1
RAM02	0x0C	0x05	0	1	0	1	0	0	0	1
RAM02	0x0D	0x05	0	1	0	0	1	0	0	1
RAM02	0x0E	0x05	0	1	0	0	0	1	1	0

**Table 14. Setting a Font Character to RAM Example**

COMMAND ADDRESS	REGISTER DATA	ACTION BEING PERFORMED
0x05	0x8A	Set font address pointer to the base address of font character RAM02.
0x05	0x42	1st 7 bits of data: 1000010 goes to font address 0x8A; pointer then autoincrements to address 0x8B.
0x05	0x61	2nd 7 bits of data: 1100001 goes to font address 0x8B; pointer then autoincrements to address 0x8C.
0x05	0x51	3rd 7 bits of data: 1010001 goes to font address 0x8C; pointer then autoincrements to address 0x8D.
0x05	0x49	4th 7 bits of data: 1001001 goes to font address 0x8D; pointer then autoincrements to address 0x8E.
0x05	0x46	5th 7 bits of data: 1000110 goes to font address 0x8E; pointer then autoincrements to address 0x8F.

**Table 15. Cursor Register Format**

MODE	COMMAND ADDRESS	REGISTER DATA								
		D7	D6	D5	D4	D3	D2	D1	D0	
Cursor register.	0x0F	<b>BLINK</b>	<b>CURSOR POSITION</b>							
Digit 1's cursor is lit continuously.	0x0F	0	0	0	0	0	0	0	0	
Digit 1's cursor is lit only for the first half of each blink period.	0x0F	1	0	0	0	0	0	0	0	
<b>UP TO</b>	0x0F	<b>UP TO</b>								
Digit 96's cursor is lit continuously.	0x0F	0	1	0	1	1	1	1	1	
Digit 96's cursor is lit only for the first half of each blink period.	0x0F	1	1	0	1	1	1	1	1	
No cursor is lit.	0x0F	X	1	1	X	X	X	X	X	

## 2-Wire Interfaced, 5 × 7 Matrix Vacuum-Fluorescent Display Controller

**MAX6853**

**Table 16. Annunciator Registers Format**

ANNUNCIATOR BYTE	REGISTER DATA							
	D7	D6	D5	D4	D3	D2	D1	D0
BIT ALLOCATIONS	ANNUNCIATOR A4		ANNUNCIATOR A3		ANNUNCIATOR A2		ANNUNCIATOR A1	
Annunciator A1 is off.	X	X	X	X	X	X	0	0
Annunciator A1 is lit only for the first half of each blink period.	X	X	X	X	X	X	0	1
Annunciator A1 is lit only for the second half of each blink period.	X	X	X	X	X	X	1	0
Annunciator A1 is lit continuously.	X	X	X	X	X	X	1	1
Annunciator A2 is off.	X	X	X	X	0	0	X	X
Annunciator A2 is lit only for the first half of each blink period.	X	X	X	X	0	1	X	X
Annunciator A2 is lit only for the second half of each blink period.	X	X	X	X	1	0	X	X
Annunciator A2 is lit continuously.	X	X	X	X	1	1	X	X
Annunciator A3 is off.	X	X	0	0	X	X	X	X
Annunciator A3 is lit only for the first half of each blink period.	X	X	0	1	X	X	X	X
Annunciator A3 is lit only for the second half of each blink period.	X	X	1	0	X	X	X	X
Annunciator A3 is lit continuously.	X	X	1	1	X	X	X	X
Annunciator A4 is off.	0	0	X	X	X	X	X	X
Annunciator A4 is lit only for the first half of each blink period.	0	1	X	X	X	X	X	X
Annunciator A4 is lit only for the second half of each blink period.	1	0	X	X	X	X	X	X
Annunciator A4 is lit continuously.	1	1	X	X	X	X	X	X

**Table 17. Configuration Register Format**

MODE	REGISTER DATA							
	D7	D6	D5	D4	D3	D2	D1	D0
Configuration register	P	M	R	T	X	B	L	S

**Table 18. Shutdown Control (S Data Bit D0) Format**

MODE	REGISTER DATA							
	D7	D6	D5	D4	D3	D2	D1	D0
Shutdown	P	M	R	T	X	B	L	0
Normal operation	P	M	R	T	X	B	L	1

**Table 19. Configuration Lock (L Data Bit D1) Format**

MODE	REGISTER DATA							
	D7	D6	D5	D4	D3	D2	D1	D0
Unlocked	P	M	R	T	X	B	0	S
Locked	P	M	R	T	X	B	1	S

## 2-Wire Interfaced, 5 × 7 Matrix Vacuum-Fluorescent Display Controller

**Table 20. Blink Rate Selection (B Data Bit D2) Format**

MODE	REGISTER DATA							
	D7	D6	D5	D4	D3	D2	D1	D0
Slow blinking (cursor and annunciators blink on for 1s, off for 1s, for OSC = 4MHz)	P	M	R	T	X	0	L	S
Fast blinking (cursor and annunciators blink on for 0.5s, off for 0.5s, for OSC = 4MHz)	P	M	R	T	X	1	L	S

**Table 21. Global Blink Timing Synchronization (T Data Bit D4) Format**

MODE	REGISTER DATA							
	D7	D6	D5	D4	D3	D2	D1	D0
Blink timing counters are unaffected.	P	M	R	0	X	B	L	S
Blink timing counters are cleared during the I <sup>2</sup> C acknowledge.	P	M	R	1	X	B	L	S

**Table 22. Global Clear Digit Data (R Data Bit D5) Format**

MODE	REGISTER DATA							
	D7	D6	D5	D4	D3	D2	D1	D0
Segment and annunciator data are unaffected.	P	M	0	T	X	B	L	S
Segment and annunciator data (address range 0x20 to 0x7F) are cleared during the I <sup>2</sup> C acknowledge.	P	M	1	T	X	B	L	S

**Table 23. Display Mode (M Data Bit D6) Format**

MODE	DISPLAY TYPE	REGISTER DATA							
		D7	D6	D5	D4	D3	D2	D1	D0
48/1	Up to 48 digits, 1 digit per grid	P	0	R	T	X	B	L	S
96/2	Up to 96 digits, 2 digits per grid	P	1	R	T	X	B	L	S

**Table 24. Blink Phase Readback (P Data Bit D7) Format**

MODE	REGISTER DATA							
	D7	D6	D5	D4	D3	D2	D1	D0
P1 blink phase	0	M	R	T	X	B	L	S
P0 blink phase	1	M	R	T	X	B	L	S

## 2-Wire Interfaced, 5 × 7 Matrix Vacuum-Fluorescent Display Controller

**MAX6853**

**Table 25. Grids Register Format**

GRIDS	COMMAND ADDRESS	REGISTER DATA								HEX CODE
		D7	D6	D5	D4	D3	D2	D1	D0	
Display has 1 grid: G0	0x03	0	0	0	0	0	0	0	0	0x00
Display has 2 grids: G0 and G1	0x03	0	0	0	0	0	0	0	1	0x01
Display has 3 grids: G0 to G2	0x03	0	0	0	0	0	0	1	0	0x02
Display has 4 grids: G0 to G3	0x03	0	0	0	0	0	0	1	1	0x03
<b>UP TO</b>	0x03	0	0	—	—	—	—	—	—	—
Display has 45 grids: G0 to G44	0x03	0	0	1	0	1	1	0	0	0x2C
Display has 46 grids: G0 to G45	0x03	0	0	1	0	1	1	0	1	0x2D
Display has 47 grids: G0 to G46	0x03	0	0	1	0	1	1	1	0	0x2E
Display has 48 grids: G0 to G47	0x03	0	0	1	0	1	1	1	1	0x2F

**Table 26. Intensity Register Format**

DUTY CYCLE	VFBLANK BEHAVIOR (OSC = 4MHz)	COMMAND ADDRESS	REGISTER DATA								HEX CODE
			D7	D6	D5	D4	D3	D2	D1	D0	
1/16 (min on)	High for 6.25μs, low for 6.25μs, high for 87.5μs	0x02	X	X	X	X	0	0	0	0	0xX0
2/16	High for 6.25μs, low for 12.5μs, high for 81.25μs	0x02	X	X	X	X	0	0	0	1	0xX1
3/16	High for 6.25μs, low for 18.75μs, high for 75μs	0x02	X	X	X	X	0	0	1	0	0xX2
4/16	High for 6.25μs, low for 25μs, high for 68.75μs	0x02	X	X	X	X	0	0	1	1	0xX3
5/16	High for 6.25μs, low for 31.25μs, high for 62.5μs	0x02	X	X	X	X	0	1	0	0	0xX4
6/16	High for 6.25μs, low for 37.5μs, high for 56.25μs	0x02	X	X	X	X	0	1	0	1	0xX5
7/16	High for 6.25μs, low for 43.75μs, high for 50μs	0x02	X	X	X	X	0	1	1	0	0xX6
8/16	High for 6.25μs, low for 50μs, high for 43.75μs	0x02	X	X	X	X	0	1	1	1	0xX7
9/16	High for 6.25μs, low for 56.25μs, high for 37.5μs	0x02	X	X	X	X	1	0	0	0	0xX8
10/16	High for 6.25μs, low for 62.5μs, high for 31.25μs	0x02	X	X	X	X	1	0	0	1	0xX9
11/16	High for 6.25μs, low for 68.75μs, high for 25μs	0x02	X	X	X	X	1	0	1	0	0xXA
12/16	High for 6.25μs, low for 75μs, high for 18.75μs	0x02	X	X	X	X	1	0	1	1	0xXB
13/16	High for 6.25μs, low for 81.25μs, high for 12.5μs	0x02	X	X	X	X	1	1	0	0	0xXC
14/16	High for 6.25μs, low for 87.5μs, high for 6.25μs	0x02	X	X	X	X	1	1	0	1	0xXD
15/16	High for 6.25μs, low for 93.75μs	0x02	X	X	X	X	1	1	1	0	0xXE
15/16 (max on)	High for 6.25μs, low for 93.75μs	0x02	X	X	X	X	1	1	1	1	0xFF

## 2-Wire Interfaced, 5 × 7 Matrix Vacuum-Fluorescent Display Controller

**Table 27. VFBLANK Polarity Register Format**

GRIDS	COMMAND ADDRESS	REGISTER DATA								HEX CODE
		D7	D6	D5	D4	D3	D2	D1	D0	
VFBLANK is high to disable the display.	0x01	X	X	X	X	X	X	0	0	0xX0
VFBLANK is low to disable the display.	0x01	X	X	X	X	X	X	1	0	0xX2

**Table 28. Display-Test and Device ID Register Format**

MODE	COMMAND ADDRESS	REGISTER DATA							
		D7	D6	D5	D4	D3	D2	D1	D0
Normal operation	0x07	X	X	X	X	X	X	X	0
Display test	0x07	X	X	X	X	X	X	X	1
Read MAX6853 device ID and display test status	0x07	0	0	0	0	0	1	1	DT

**Table 29. Shift-Limit Register Format**

SHIFT LIMIT	COMMAND ADDRESS	REGISTER DATA								HEX CODE
		D7	D6	D5	D4	D3	D2	D1	D0	
Minimum setting example (01)	0x0E	0	0	0	0	0	0	0	1	0x01
Maximum setting example (121 or 0x79)	0x0E	0	1	1	1	1	0	0	1	0x79

## 2-Wire Interfaced, 5 × 7 Matrix Vacuum-Fluorescent Display Controller

**MAX6853**

**Table 30. Output Map RAM Codes**

OUTPUT MAP RAM CODE (DECIMAL)	APPLICATION	FUNCTION MAPPED BY OUTPUT MAP RAM CODE
0 to 47	48 grids	Grids G0 to G47
48, 49, 50, 51, 52	5 x 7 matrix character segments  Digits 0 to 47 only  Use character registers 0x20 to 0x4F <b>(Figure 12)</b>	5 x 7 matrix character segments 1-1, 2-1, 3-1, 4-1, 5-1
53, 54, 55, 56, 57		5 x 7 matrix character segments 1-2, 2-2, 3-2, 4-2, 5-2
58, 59, 60, 61, 62		5 x 7 matrix character segments 1-3, 2-3, 3-3, 4-3, 5-3
63, 64, 65, 66, 67		5 x 7 matrix character segments 1-4, 2-4, 3-4, 4-4, 5-4
68, 69, 70, 71, 72		5 x 7 matrix character segments 1-5, 2-5, 3-5, 4-5, 5-5
73, 74, 75, 76, 77		5 x 7 matrix character segments 1-6, 2-6, 3-6, 4-6, 5-6
78, 79, 80, 81, 82		5 x 7 matrix character segments 1-7, 2-7, 3-7, 4-7, 5-7
83		5 x 7 matrix character segment DP
84, 85, 86, 87, 88	5 x 7 matrix character segments  Digits 48 to 95 only  Use character registers 0x50 to 0x7F <b>(Figure 12)</b> <b>Only valid for 96/2 mode</b> (display mode select bit M = 1)	5 x 7 matrix character segments 1-1, 2-1, 3-1, 4-1, 5-1
89, 90, 91, 92, 93	—	5 x 7 matrix character segments 1-2, 2-2, 3-2, 4-2, 5-2
94, 95, 96, 97, 98	—	5 x 7 matrix character segments 1-3, 2-3, 3-3, 4-3, 5-3
99, 100, 101, 102, 103		5 x 7 matrix character segments 1-4, 2-4, 3-4, 4-4, 5-4
104, 105, 106, 107, 108		5 x 7 matrix character segments 1-5, 2-5, 3-5, 4-5, 5-5
109, 110, 111, 112, 113		5 x 7 matrix character segments 1-6, 2-6, 3-6, 4-6, 5-6
114, 115, 116, 117, 118		5 x 7 matrix character segments 1-7, 2-7, 3-7, 4-7, 5-7
119		—
120 to 123	4 annunciators  <b>Only valid for 48/1 mode</b> (display mode select bit M = 0)	Annunciator A1 to annunciator A4
124	Cursor	Cursor segment for digits 0 to 47 only
125	Cursor  <b>Only valid for 96/2 mode</b> (display mode select bit M = 1)	Cursor segment for digits 48 to 95 only
126, 127	Unused	No action

## 2-Wire Interfaced, 5 × 7 Matrix Vacuum-Fluorescent Display Controller

**Table 31. Output Map RAM Initial Power-Up Status**

OUTPUT MAP RAM ADDRESS	OUTPUT MAP RAM CODE ON POWER-UP (DECIMAL)	FUNCTION MAPPED BY OUTPUT MAP RAM CODE
0x00 to 0x27	0–39	Grids 0–39
0x28, 0x29, 0x2A, 0x2B, 0x2C	48, 49, 50, 51, 52	5 × 7 matrix character segments 1-1, 2-1, 3-1, 4-1, 5-1
0x2D, 0x2E, 0x2F, 0x30, 0x31	53, 54, 55, 56, 57	5 × 7 matrix character segments 1-2, 2-2, 3-2, 4-2, 5-2
0x32, 0x33, 0x34, 0x35, 0x36	58, 59, 60, 61, 62	5 × 7 matrix character segments 1-3, 2-3, 3-3, 4-3, 5-3
0x37, 0x38, 0x39, 0x3A, 0x3B	63, 64, 65, 66, 67	5 × 7 matrix character segments 1-4, 2-4, 3-4, 4-4, 5-4
0x3C, 0x3D, 0x3E, 0x3F, 0x40	68, 69, 70, 71, 72	5 × 7 matrix character segments 1-5, 2-5, 3-5, 4-5, 5-5
0x41, 0x42, 0x43, 0x44, 0x45	73, 74, 75, 76, 77	5 × 7 matrix character segments 1-6, 2-6, 3-6, 4-6, 5-6
0x46, 0x47, 0x48, 0x49, 0x4A	78, 79, 80, 81, 82	5 × 7 matrix character segments 1-7, 2-7, 3-7, 4-7, 5-7
0x4B	83	5 × 7 matrix character segment DP
0x4C, 0x4D, 0x4E, 0x4F, 0x50	84, 85, 86, 87, 88	5 × 7 matrix character segments 1-1, 2-1, 3-1, 4-1, 5-1
0x51, 0x52, 0x53, 0x54, 0x55	89, 90, 91, 92, 93	5 × 7 matrix character segments 1-2, 2-2, 3-2, 4-2, 5-2
0x56, 0x57, 0x58, 0x59, 0x5A	94, 95, 96, 97, 98	5 × 7 matrix character segments 1-3, 2-3, 3-3, 4-3, 5-3
0x5B, 0x5C, 0x5D, 0x5E, 0x5F	99, 100, 101, 102, 103	5 × 7 matrix character segments 1-4, 2-4, 3-4, 4-4, 5-4
0x60, 0x61, 0x62, 0x63, 0x64	104, 105, 106, 107, 108	5 × 7 matrix character segments 1-5, 2-5, 3-5, 4-5, 5-5
0x65, 0x66, 0x67, 0x68, 0x69	109, 110, 111, 112, 113	5 × 7 matrix character segments 1-6, 2-6, 3-6, 4-6, 5-6
0x6A, 0x6B, 0x6C, 0x6D, 0x6E	114, 115, 116, 117, 118	5 × 7 matrix character segments 1-7, 2-7, 3-7, 4-7, 5-7
0x6F	119	5 × 7 matrix character segment DP
0x70	124	Cursor segment for digits 0 to 47, 1st row
0x71	125	Cursor segment for digits 0 to 47, 2nd row
0x72 to 0x79	127	No action

**Table 32. Setting Output Map Address Pointer**

MODE	COMMAND ADDRESS	REGISTER DATA							
		D7	D6	D5	D4	D3	D2	D1	D0
Set output map address to minimum (0x00) with data 0x80. (Note that this address is set as a power-up default.)	0x06	1	0	0	0	0	0	0	0
Set output map address to maximum 0x79 with data 0xF9.	0x06	1	1	1	1	1	0	0	1

**Table 33. Writing Output Map Data**

MODE	COMMAND ADDRESS	REGISTER DATA							
		D7	D6	D5	D4	D3	D2	D1	D0
Write output map data; output map address pointer is autoincremented after the output map data has been written to the current location.	0x06	0	7 bits of output map data						

## 2-Wire Interfaced, 5 × 7 Matrix Vacuum-Fluorescent Display Controller

**Table 34. Reading Output Map Data**

MODE	COMMAND ADDRESS	REGISTER DATA								
		D7	D6	D5	D4	D3	D2	D1	D0	
Read output map data; output map address pointer is autoincremented after the output map data has been read from the current location.	0x06	0	7 bits of output map data							

**Table 35. Filament Bridge Driver Timing**

TIMING POINT	PHASE1 BEHAVIOR	PHASE2 BEHAVIOR	EXAMPLE 1 DUTY = 1 (MIN)	EXAMPLE 2 DUTY = 100	EXAMPLE 3 DUTY = 198
(A)	Low for (199 - FilOn) cycles	Low for (199 - FilOn) cycles	198	99	1
(B)	Low for (FilOn) cycles	High for (FilOn) cycles	1	100	198
(C)	Low for (2) cycles	Low for (2) cycles	2	2	2
(D)	High for (FilOn) cycles	Low for (FilOn) cycles	1	100	198
(E)	Low for (199 - FilOn) cycles	Low for (199 - FilOn) cycles	198	99	1
<b>Total 4MHz cycles (OSC = 4MHz)</b>	<b>400 cycles = 100µs</b>	<b>400 cycles = 100µs</b>	<b>400 cycles = 100µs</b>	<b>400 cycles = 100µs</b>	<b>400 cycles = 100µs</b>

**Table 36. Filament Duty-Cycle Register Format**

FILAMENT DUTY CYCLE	COMMAND ADDRESS	REGISTER DATA								HEX CODE
		D7	D6	D5	D4	D3	D2	D1	D0	
Minimum setting example (01)	0x09	0	0	0	0	0	0	0	1	0x01
Maximum setting example (199 or 0xC7)	0x09	1	1	0	0	0	1	1	1	0xC7

**Table 37. PHASE1 Register Format**

PHASE1 BEHAVIOR	COMMAND ADDRESS	REGISTER DATA								HEX CODE
		D7	D6	D5	D4	D3	D2	D1	D0	
General-purpose output, logic 0. <b>This is the power-up condition.</b>	0x0A	X	X	X	X	X	X	0	0	0xX0
General-purpose output, logic 1.	0x0A	X	X	X	X	X	X	0	1	0xX1
Output gives blink status: zero if blink phase P0; 1 if blink phase P1.	0x0A	X	X	X	X	X	X	1	0	0xX2
Filament drive PHASE1 (logic 0 during shutdown).	0x0A	X	X	X	X	X	X	1	1	0xX3

## 2-Wire Interfaced, 5 × 7 Matrix Vacuum-Fluorescent Display Controller

Table 38. PHASE2 Register Format

PHASE2 BEHAVIOR	COMMAND ADDRESS	REGISTER DATA								HEX CODE
		D7	D6	D5	D4	D3	D2	D1	D0	
General-purpose output, logic 0. <b>This is the power-up condition.</b>	0x0B	X	X	X	X	X	X	0	0	0xX0
General-purpose output, logic 1.	0x0B	X	X	X	X	X	X	0	1	0xX1
Output gives blink status: zero if blink phase P0; 1 if blink phase P1.	0x0B	X	X	X	X	X	X	1	0	0xX2
Filament drive PHASE2 (logic 0 during shutdown).	0x0B	X	X	X	X	X	X	1	1	0xX3

Table 39. PORT0 Register Format

PORT0 PORT BEHAVIOR	COMMAND ADDRESS	REGISTER DATA								HEX CODE
		D7	D6	D5	D4	D3	D2	D1	D0	
General-purpose output, logic 0. <b>This is the power-up condition.</b>	0x0C	X	X	X	X	X	0	0	0	0xX0
General-purpose output, logic 1.	0x0C	X	X	X	X	X	0	0	1	0xX1
Output gives blink status: zero if blink phase P0; 1 if blink phase P1.	0x0C	X	X	X	X	X	0	1	0	0xX2
Output blink status: 1 if blink phase P0; zero if blink phase P1.	0x0C	X	X	X	X	X	0	1	1	0xX3
625Hz square-wave output zero in shutdown.	0x0C	X	X	X	X	X	1	0	0	0xX4
1250Hz square-wave output zero in shutdown.	0x0C	X	X	X	X	X	1	0	1	0xX5
2500Hz square-wave output zero in shutdown.	0x0C	X	X	X	X	X	1	1	0	0xX6
Output gives shutdown status: zero if shutdown mode; 1 if operating mode.	0x0C	X	X	X	X	X	1	1	1	0xX7

## 2-Wire Interfaced, 5 × 7 Matrix Vacuum-Fluorescent Display Controller

**MAX6853**

**Table 40. PORT1 Register Format**

PORT1 PORT BEHAVIOR	COMMAND ADDRESS	REGISTER DATA								HEX CODE
		D7	D6	D5	D4	D3	D2	D1	D0	
General-purpose output, logic 0.	0x0D	X	X	X	X	X	0	0	0	0xX0
General-purpose output, logic 1. <b>This is the power-up condition.</b>	0x0D	X	X	X	X	X	0	0	1	0xX1
Output gives blink status: zero if blink phase P0; 1 if blink phase P1.	0x0D	X	X	X	X	X	0	1	0	0xX2
Output blink status: 1 if blink phase P0; zero if blink phase P1.	0x0D	X	X	X	X	X	0	1	1	0xX3
Inverted 625Hz square-wave output 1 in shutdown.	0x0D	X	X	X	X	X	1	0	0	0xX4
Inverted 1250Hz square-wave output 1 in shutdown.	0x0D	X	X	X	X	X	1	0	1	0xX5
Inverted 2500Hz square-wave output 1 in shutdown.	0x0D	X	X	X	X	X	1	1	0	0xX6
Output gives inverted shutdown status: 1 if shutdown mode; zero if operating mode.	0x0D	X	X	X	X	X	1	1	1	0xX7

**Table 41. PUMP Register Format**

PUMP PORT BEHAVIOR	COMMAND ADDRESS	REGISTER DATA								HEX CODE
		D7	D6	D5	D4	D3	D2	D1	D0	
General-purpose output, logic 0. <b>This is the power-up condition.</b>	0x08	X	X	X	X	X	X	0	0	0xX0
General-purpose output, logic 1.	0x08	X	X	X	X	X	X	0	1	0xX1
80kHz square-wave output (OSC = 4MHz) (logic 0 during shutdown).	0x08	X	X	X	X	X	X	1	0	0xX2
80kHz square-wave output (OSC = 4MHz) (logic 1 during shutdown).	0x08	X	X	X	X	X	X	1	1	0xX3

# 2-Wire Interfaced, 5 × 7 Matrix Vacuum-Fluorescent Display Controller

**Functional Diagram**

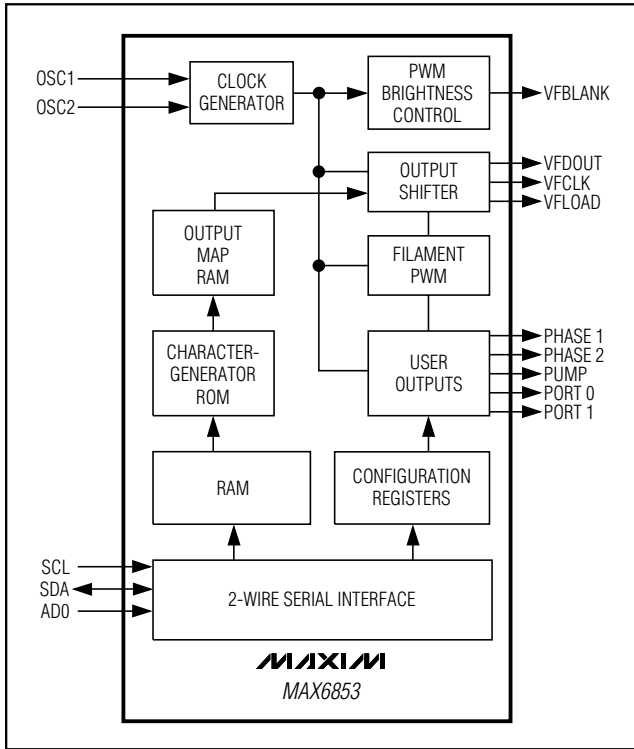

**Pin Configuration**

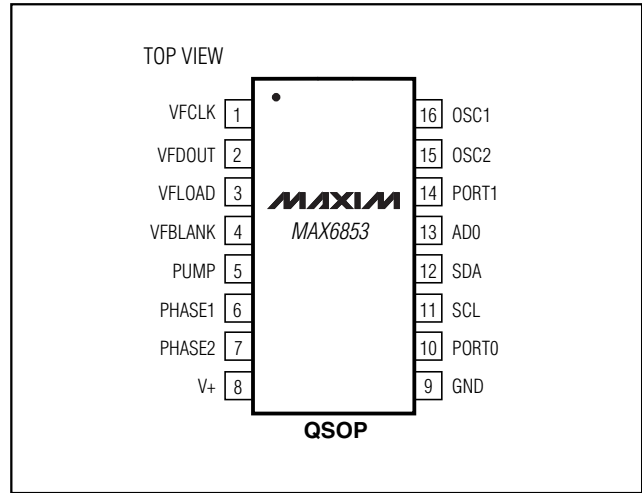

**Chip Information**

TRANSISTOR COUNT: 199,083  
 PROCESS: CMOS

# 2-Wire Interfaced, 5 × 7 Matrix Vacuum-Fluorescent Display Controller

## Package Information

(The package drawing(s) in this data sheet may not reflect the most current specifications. For the latest package outline information, go to [www.maxim-ic.com/packages](http://www.maxim-ic.com/packages).)

**MAX6853**

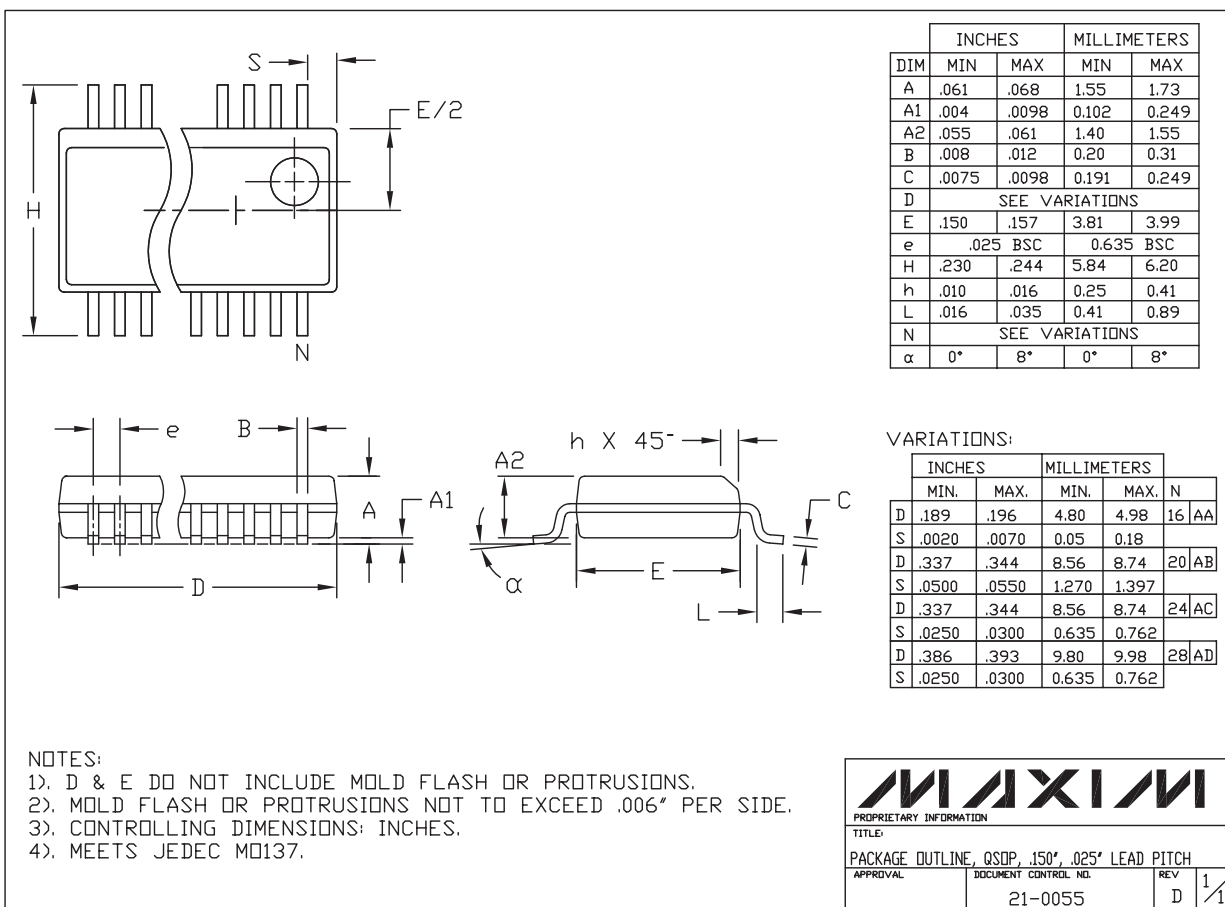

**MAXIM**  
 PROPRIETARY INFORMATION  
 TITLE:  
 PACKAGE OUTLINE, QSOP, .150", .025" LEAD PITCH  
 APPROVAL: \_\_\_\_\_ DOCUMENT CONTROL NO. 21-0055 REV D 1/1

Maxim cannot assume responsibility for use of any circuitry other than circuitry entirely embodied in a Maxim product. No circuit patent licenses are implied. Maxim reserves the right to change the circuitry and specifications without notice at any time.

Maxim Integrated Products, 120 San Gabriel Drive, Sunnyvale, CA 94086 408-737-7600 35