

MAXIM

MAX1677 Evaluation Kit

General Description

The MAX1677 evaluation kit (EV kit) is a fully assembled and tested surface-mount circuit board that contains two separate switching-regulator circuits. The first circuit is configured for a +3.3V main output and +20V LCD bias voltage. It accepts inputs from +0.7V to +3.3V. The main +3.3V output supplies up to 350mA from a 2-cell input, or 140mA from a 1-cell input, while the LCD bias output supplies up to 12mA at +20V.

The second circuit converts a +0.7V to +3.3V battery voltage to a +3.3V main output and a -20V LCD bias voltage. The main +3.3V output supplies up to 350mA from a 2-cell input, or 140mA from a 1-cell input, while the LCD bias output supplies 10mA at -20V.

The MAX1677 features internal N-channel MOSFET switches, a synchronous rectifier, low-battery comparator, and selectable PFM/PWM mode. The MAX1677 EV kit provides low quiescent current and high efficiency—up to 95% for maximum battery life. Operation at 300kHz allows the use of tiny surface-mount inductors.

Features

- ◆ +0.7V to MAINOUT Battery Input Voltage
- ◆ Dual Output Voltages
 - +3.3V Main Output and +20V LCD Bias Output
 - +3.3V Main Output and -20V LCD Bias Output
- ◆ All Outputs Also Adjustable with External Resistors
- ◆ Up to 350mA from 2-Cell Input (Main Output)
- ◆ Up to 140mA from 1-Cell Input (Main Output)
- ◆ Up to 12mA Output Current (LCD Bias Output)
- ◆ Internal N-Channel Switches and Synchronous Rectifier
- ◆ 1µA IC Shutdown Current
- ◆ 300kHz Switching Frequency
- ◆ Surface-Mount Components
- ◆ Fully Assembled and Tested

Ordering Information

PART	TEMP. RANGE	IC PACKAGE
MAX1677EVKIT	0°C to +70°C	16 QSOP

Component List

DESIGNATION	QTY	DESCRIPTION
C1, C2, C10, C11	4	100µF, 10V low-ESR tantalum caps AVX TPSD107M010R0100 or Sprague 593D107X0010D2T
C3, C5, C13, C14	4	0.1µF ceramic capacitors
C4, C12	2	4.7µF, 35V tantalum capacitors AVX TPSC475M035R0600 or Sprague 595D475X0035C2T
C8	1	2.2µF, 25V ceramic capacitor United Chemi-Con/Marcon THCR30E1E225Z
C16, C17	2	1µF, 16V ceramic capacitors Taiyo Yuden EMK316BJ105KL TDK C3216X7R1C105M
C6, C7, C9, C15, D6	0	Not installed
D1, D3	2	20V, 0.5A Schottky diodes Motorola MBR0520LT3
D2, D4, D5	3	40V, 0.5A Schottky diodes Motorola MBR0540T3

DESIGNATION	QTY	DESCRIPTION
L1, L3	2	10µH inductors Sumida CR54-100
L2, L4	2	10µH inductors Murata LQH4N100K04 TDK NLC32522T-100K
R3	1	1.5MΩ ±5% resistor
R4, R12	2	100kΩ ±5% resistors
R5, R13	2	10Ω ±5% resistors
R11	1	1.6MΩ ±5% resistor
R1, R2, R6–R10, R14–R16	0	Not installed
U1, U2	2	MAX1677EEE
JU1–JU6	6	3-pin headers
None	6	Shunts
None	1	MAX1677 PC board
None	1	MAX1677 data sheet

Evaluates: MAX1677



MAX1677 Evaluation Kit

Component Suppliers

SUPPLIER	PHONE	FAX
AVX	803-946-0690	803-626-3123
Dale-Vishay	402-564-3131	402-563-6418
Motorola	602-303-5454	602-994-6430
Murata	814-237-1431	814-238-0490
Sprague	603-224-1961	603-224-1430
Sumida	708-956-0666	708-956-0702
Taiyo Yuden	408-573-4150	408-573-4159
TDK	847-390-4373	847-390-4428
United Chemi-Con/Marcon	847-696-2000	847-696-9278

Note: Please indicate that you are using the MAX1677 when contacting these component suppliers.

Quick Start

The MAX1677 EV kit is fully assembled and tested. Follow these steps to verify board operation. **Do not turn on the power supply until all connections are completed.**

+3.3V and +LCD Output

- 1) Connect a +1.1V to +3.3V supply to the VIN pad. Connect the ground to the GND pad. Note: The input voltage may drop as low as 0.7V after startup.
- 2) Connect voltmeters to the VOUT and +LCDOUT pads.
- 3) Verify that the shunts are across pins 2 and 3 on JU1, JU2, and JU3.
- 4) Turn on the power supply and verify that the main output is at +3.3V and the LCD bias output is at +20V.

+3.3V and -LCD Output

- 1) Connect a +1.1V to +3.3V supply to the VIN pad. Connect the ground to the GND pad. Note: The input voltage may drop as low as 0.7V after start-up.
- 2) Connect voltmeters to the VOUT and -LCDOUT pads.
- 3) Verify that the shunts are across pins 2 and 3 on JU4, JU5, and JU6.
- 4) Turn on the power supply and verify that the main output is at +3.3V and the -LCD Bias output is at -20V.

For instructions on selecting the feedback resistors for other output voltages, refer to the *Design Procedure* section in the MAX1677 data sheet.

Detailed Description

The MAX1677 EV kit contains two separate switching-regulator circuits. The first circuit provides a +3.3V main output and +20V LCD bias output. The second circuit provides a +3.3V main output and -20V LCD bias output. Both circuits require a +0.7V to +3.3V input voltage range. The main +3.3V output supplies up to 350mA from a 2-cell input, or 140mA from a 1-cell input, while the LCD bias output supplies up to 12mA.

The main output voltage can also be adjusted from +2.5V to +5.5V with external resistors. The LCD output is also adjustable. The main boost converter has three operational modes: a low-power PFM mode, a high-power PWM mode, and a high-power PWM mode with the internal oscillator synchronized to an external clock.

Jumper Selection

Shutdown Mode

The MAX1677 EV kit features a shutdown mode that reduces the MAX1677 quiescent current to less than 1mA (typ), preserving battery life. The 3-pin headers, JU1 and JU4, select the shutdown mode for each circuit. Table 1 lists the selectable jumper options.

Controlling the LCD Using LCDON Pin

LCDON is used to turn on the LCD bias voltage. Jumpers JU2 and JU5 control the LCDON pins for the +LCD and -LCD output circuits, respectively. The 3.3V outputs must also be on for the LCD outputs to operate. Table 2 lists the LCDON jumper options.

Table 1. Jumper JU1/JU4 Functions

SHUNT LOCATION	ON PIN	VOUT OUTPUT
1 & 2	Connected to GND	Shutdown mode, $V_{OUT} = V_{IN} - V_{DIODE}$
2 & 3	Connected to VOUT	MAX1677 enabled, $V_{OUT} = +3.3V$

Table 2. Jumper JU2/JU5 Functions

SHUNT LOCATION	LCDON PIN	LCDOUT OUTPUT
1 & 2	Connected to GND	+LCDOUT = $V_{IN} - V_{DIODE}$, -LCDOUT = 0V
2 & 3	Connected to VOUT	+LCDOUT = +20V, -LCDOUT = -20V

MAX1677 Evaluation Kit

Evaluates: MAX1677

Operating Mode

The main boost converter has three operational modes: a low-power PFM mode; a high-power, low-noise PWM mode; and a high-power PWM mode with the internal oscillator synchronized to an external clock. The EV kit operates at 300kHz switching frequency and allows the use of small inductor values. The switching frequency can also be synchronized to an external clock ranging from 200kHz to 400kHz. The 3-pin headers JU3 and JU6 select the operating mode for each circuit. Table 3 lists the jumper options.

Table 3. Jumper JU3/JU6 Functions

SHUNT LOCATION	CLK/SEL PIN	OPERATING MODE
1 & 2	Connected to GND	Low-power mode, MAX1677 operates in the PFM mode.
2 & 3	Connected to V _{OUT}	High-power, low-noise mode, MAX1677 operates in the PWM mode.
Open	CLK/SEL connected to CLK/SEL pad	Synchronized PWM high-power mode, CLK/SEL pin is driven by an external clock between 200kHz and 400kHz.

Evaluating Other Output Voltages

The main output is set to +3.3V by grounding the feedback pins (FB) via PC traces shorting R2 and R10. To generate main output voltages other than +3.3V (+2.5V to +5.5V), cut the traces across R2 and R10 and select the external voltage divider resistors (R1, R2 or R9, and R10). Refer to *Design Procedure* section in the MAX1677 data sheet for instructions on selecting R1, R2 and R9, and R10.

The ±20V LCD bias output voltages are set with voltage dividers (R3, R4 or R11, and R12) at the LCD feedback pins (LCDFB). To generate LCD output voltages other than ±20V, refer to *Setting the LCD Output Voltage* section in the MAX1677 data sheet.

Changing the LCD Current Limit

The LCD inductor current limit can be set to 225mA or 350mA. The EV kit is factory-configured for 350mA. To set the limit to 225mA, cut the PC trace shorting R17 or R18 and insert a 56kΩ resistor. This allows the use of the smallest possible inductors for low-current displays. See the *LCD Boost Converter* section of the MAX1677 data sheet for more information.

MAX1677 Evaluation Kit

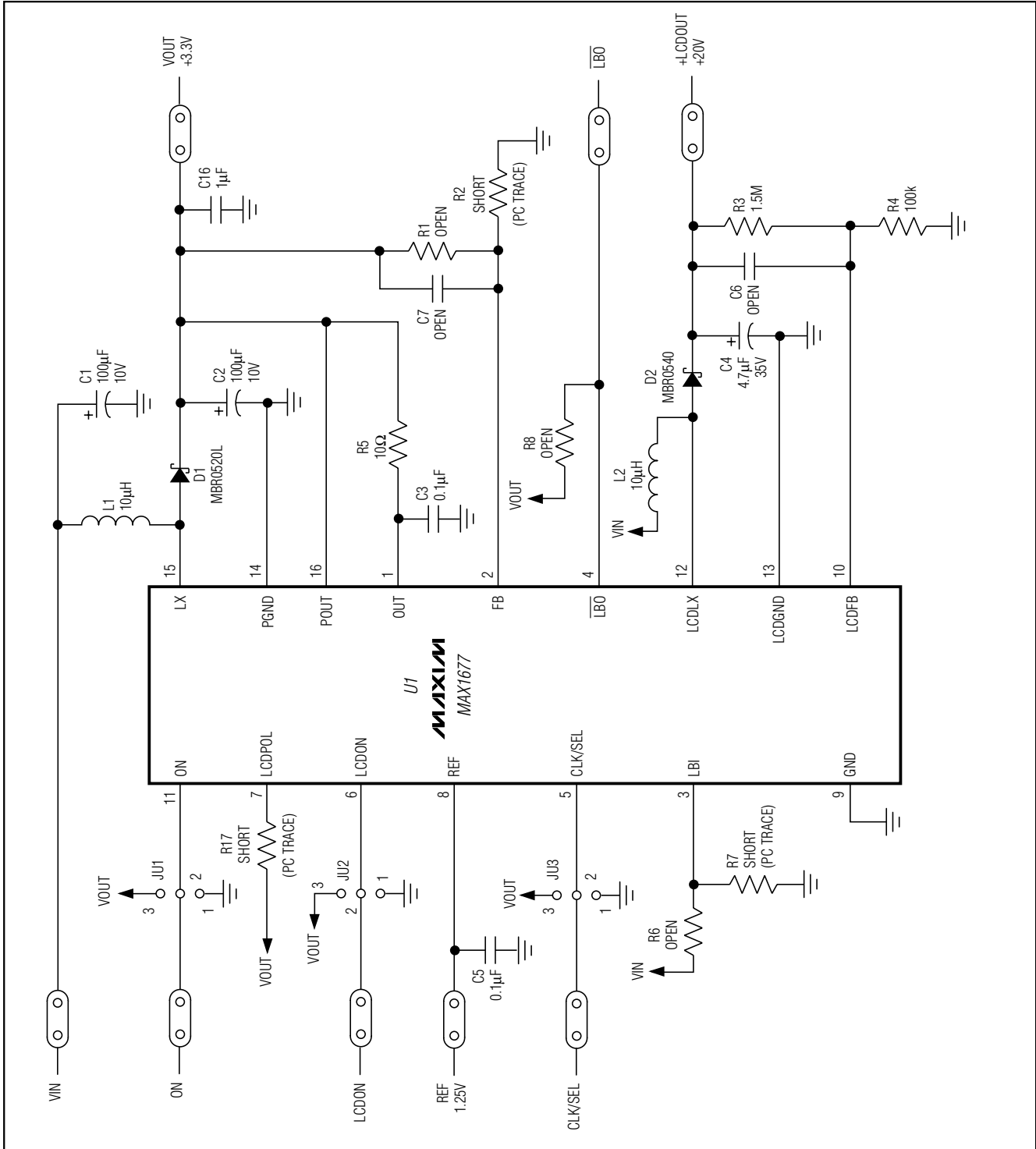

Figure 1. MAX1677 EV Kit Schematic (Positive LCD)

MAX1677 Evaluation Kit

Evaluates: MAX1677

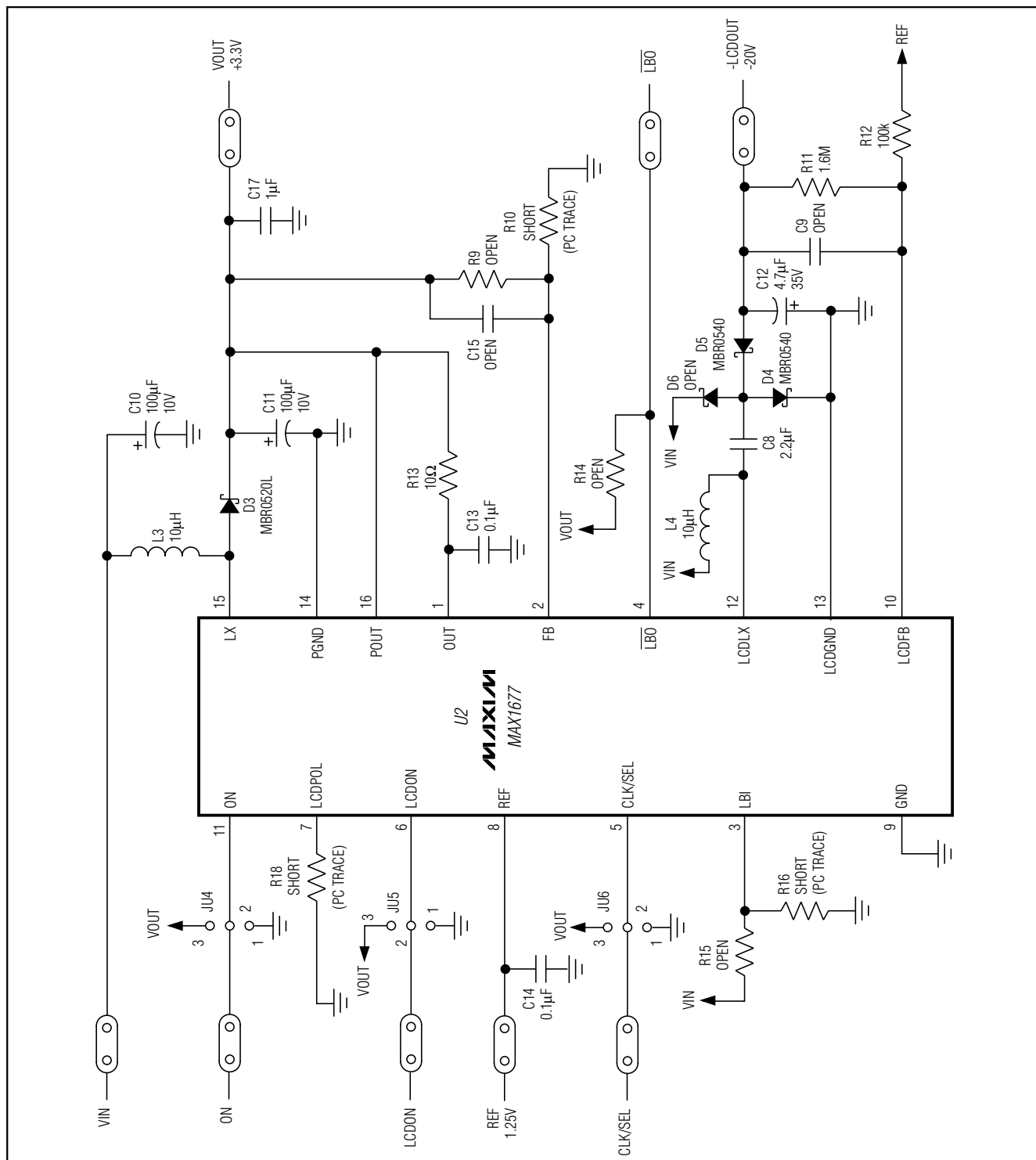

Figure 2. MAX1677 EV Kit Schematic (Negative LCD)

MAX1677 Evaluation Kit

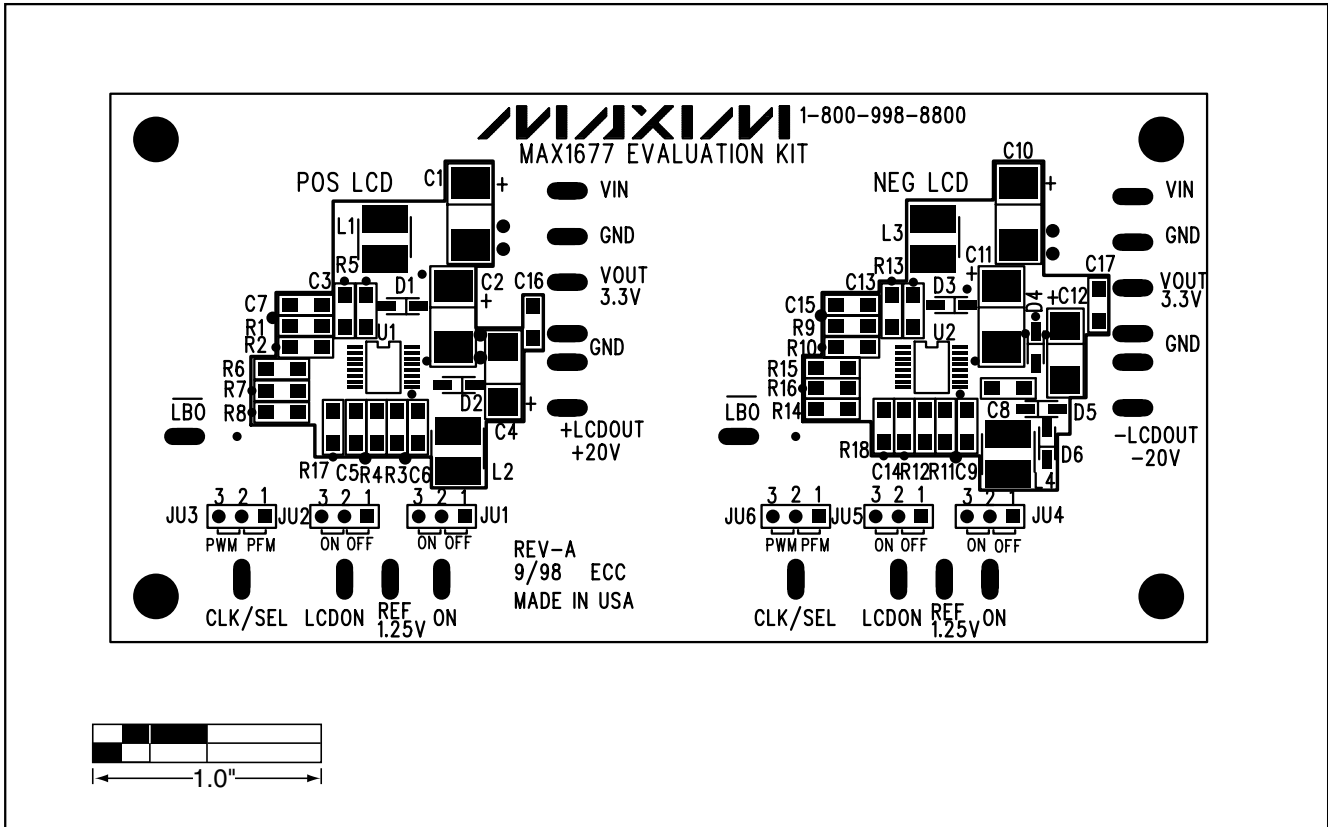

Figure 3. MAX1677 EV Kit Component Placement Guide—Component Side

MAX1677 Evaluation Kit

Evaluates: MAX1677

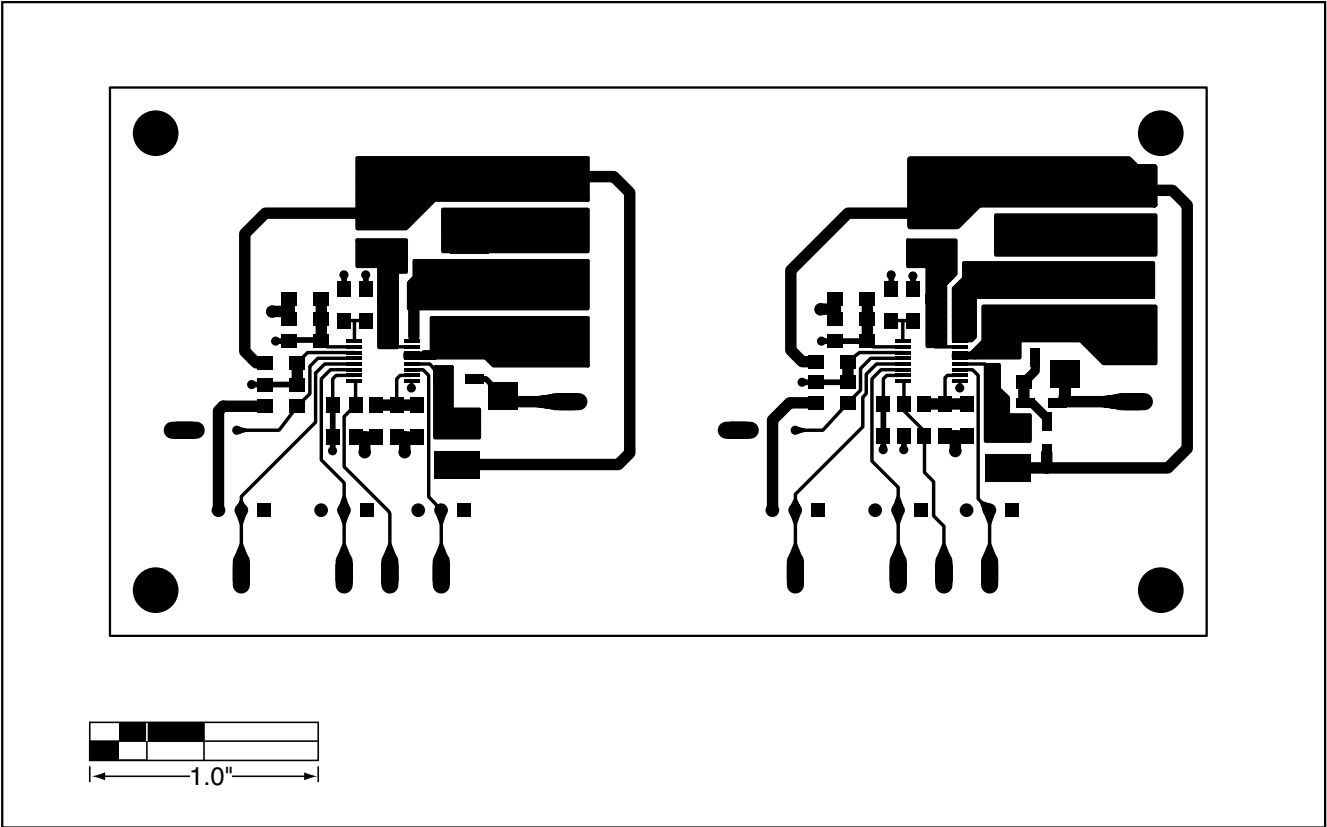

Figure 4. MAX1677 EV Kit PC Board Layout—Component Side

MAX1677 Evaluation Kit

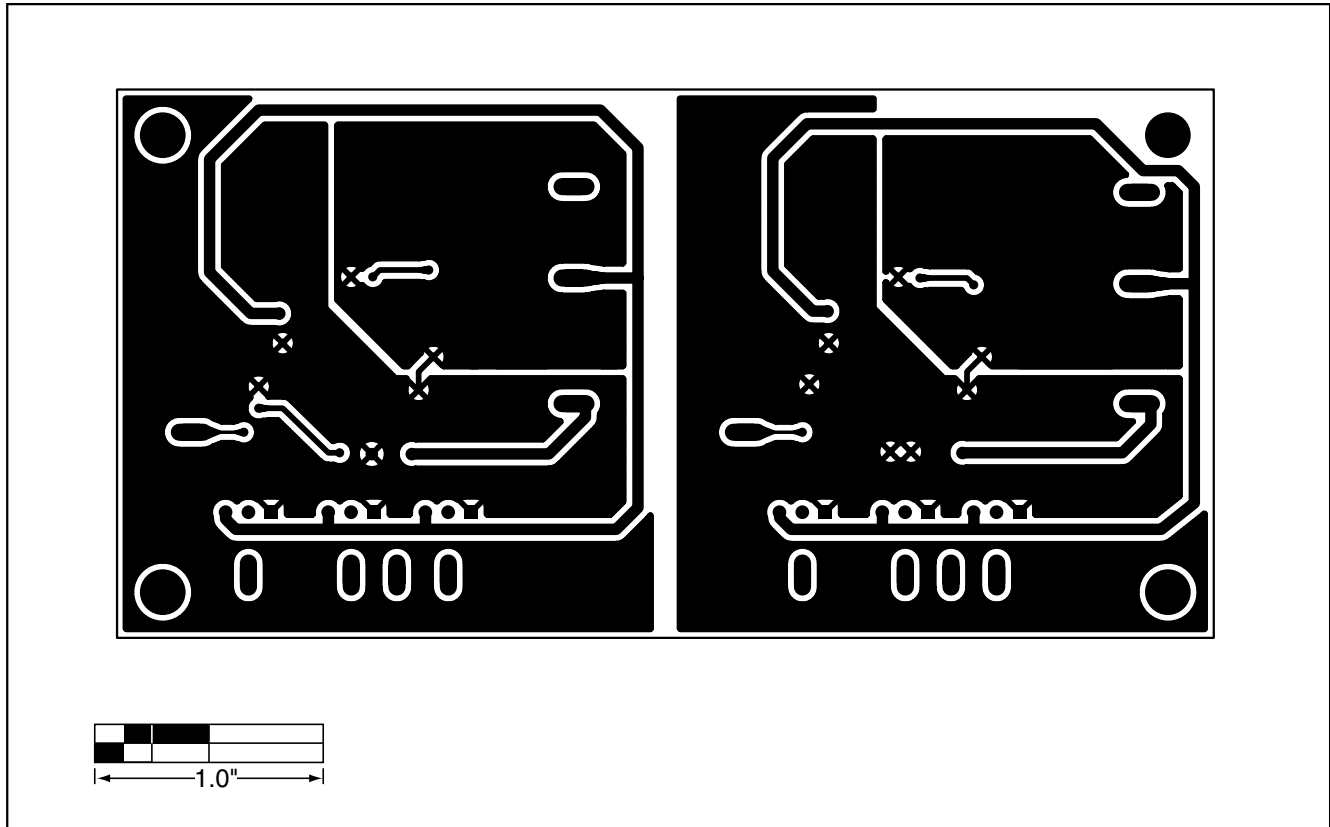

Figure 5. MAX1677 EV Kit PC Board Layout—Solder Side

Maxim cannot assume responsibility for use of any circuitry other than circuitry entirely embodied in a Maxim product. No circuit patent licenses are implied. Maxim reserves the right to change the circuitry and specifications without notice at any time.