

# MAXIM

## MAX774 Evaluation Kit

MAX774 EV Kit

### General Description

The MAX774 evaluation kit (EV kit) is a fully assembled and tested surface-mount printed circuit board that provides a regulated -5.0V output voltage from a +5.0V input source. It drives loads up to 1A with conversion efficiency greater than 80%.

Additional pads are provided on the board's solder side to accommodate external feedback resistors for setting different output voltages.

The MAX774 EV kit can also be used to evaluate the MAX775 (-12V output) or MAX776 (-15V output).

### Component List

DESIGNATION	QTY	DESCRIPTION
C1	1	150 $\mu$ F, 10V low-ESR tantalum capacitor Sprague 595D157X0010D7
C3	1	330 $\mu$ F, 10V low-ESR tantalum capacitor Sprague 595D337X0010R7
C2, C4	2	0.1 $\mu$ F, 50V ceramic capacitors
R1	1	0.075 $\Omega$ resistor (low inductance) IRC LR2010-01-R075-F
R2, R3	0	Open
L1	1	22 $\mu$ H, 2.3A power inductor Sumida CDR125-220
D1	1	3A Schottky diode 1N5820 or Nihon NSQ03A03
Q1	1	P-channel FET (BV <sub>DS</sub> = 30V, r <sub>DS(ON)</sub> = 130m $\Omega$ at 4.5V <sub>GS</sub> ), Siliconix Si9435
U1	1	MAX774CSA (8-pin SO)
JU1	1	3-pin header
None	1	Shunt
None	1	PC board
None	1	MAX774 data sheet

### Component Suppliers

SUPPLIER	PHONE	FAX
AVX	(800) 282-4975	(207) 283-1941
Coilcraft	(708) 639-6400	(708) 639-1469
Coiltronics	(407) 241-7876	(407) 241-9339
Harris	(407) 724-3739	(407) 724-3937
IRC	(704) 264-8861	(704) 264-8866
Matsuo	(714) 969-2491	(714) 960-6492
Motorola	(800) 521-6274	(602) 244-4015
Nihon	(805) 867-2555	(805) 867-2556
Siliconix	(408) 988-8000	(408) 970-3950
Sprague	(603) 224-1961	(603) 224-1430
Sumida	(708) 956-0666	(708) 956-0702

### Features

- ◆ -5.0V or Adjustable Output Voltage
- ◆ Up to 1A Output Current
- ◆ 5 $\mu$ A Max Shutdown Current
- ◆ 100 $\mu$ A Max Supply Current
- ◆ 300kHz Switching Frequency
- ◆ 8-Pin DIP and SO Packages
- ◆ Surface-Mount Construction
- ◆ Fully Assembled and Tested

### Ordering Information

PART	TEMP. RANGE	BOARD TYPE
MAX774EVKIT-SO	0°C to +70°C	Surface Mount

### EV Kit



# MAX774 Evaluation Kit

## Quick Reference

The MAX774 EV kit is a fully assembled and tested surface-mount board. Follow the steps below to verify board operation.

**Do not turn on the power supply until all connections are completed.**

1. Connect a +5.0V supply to the pad marked VIN. Ground connects to the GND pad.
2. Connect a voltmeter and load (if any) to the VOUT pad.
3. Place the shunt on JU1 across pins 1 and 2 for normal operation.
4. Turn on the power and verify the output voltage is -5.0V.
5. Refer to the sections *Evaluating the MAX775 and MAX776* and *Other Output Voltages* to modify the board for different output voltages.

## Detailed Description

### Jumper Selections

The 3-pin header JU1 selects shutdown mode. Table 1 lists the selectable jumper options.

### Inductor Selection

The 22μH Sumida CDR125-220 inductor mounted on the EV kit is a low-resistance, shielded, medium-current inductor. It provides excellent performance over the line and load ranges of the MAX774/MAX775/MAX776. See the *Choosing an Inductor* section of the MAX774/MAX775/MAX776 data sheet for more inductor selection information.

**Table 1. Jumper JU1 Functions**

SHUNT LOCATION	SHDN PIN	MAX774 OUTPUT
2 & 3	Connected to VIN	Shutdown mode, VOUT = 0V
1 & 2	Connected to GND	MAX774 enabled, VOUT = -5.0V

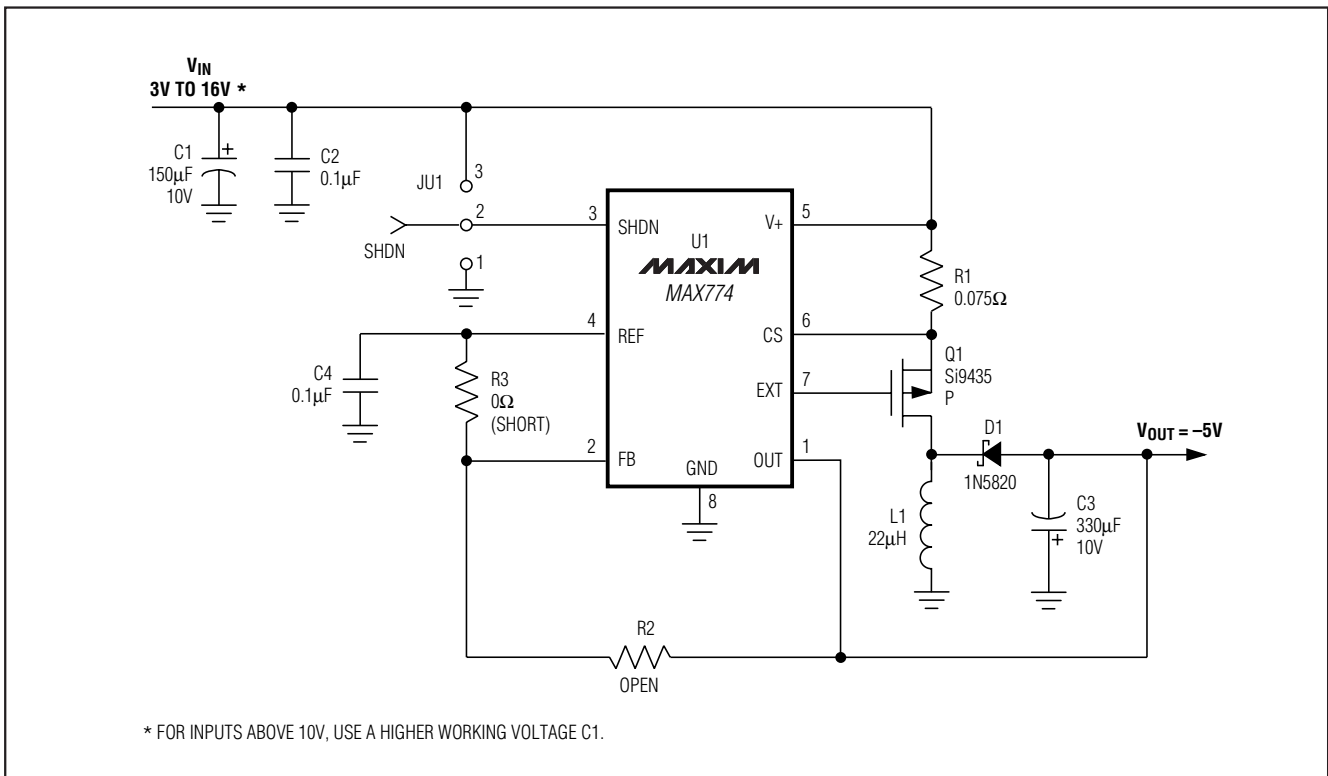

Figure 1. MAX774 EV Kit Schematic Diagram

# MAX774 Evaluation Kit

MAX774 EV Kit

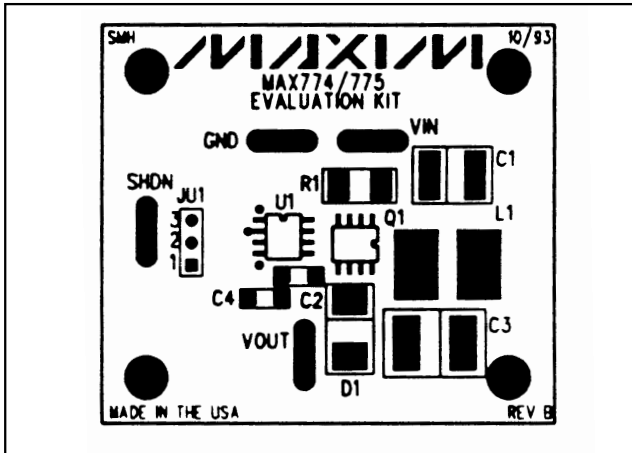

Figure 2. Component Placement Guide (Component Side)

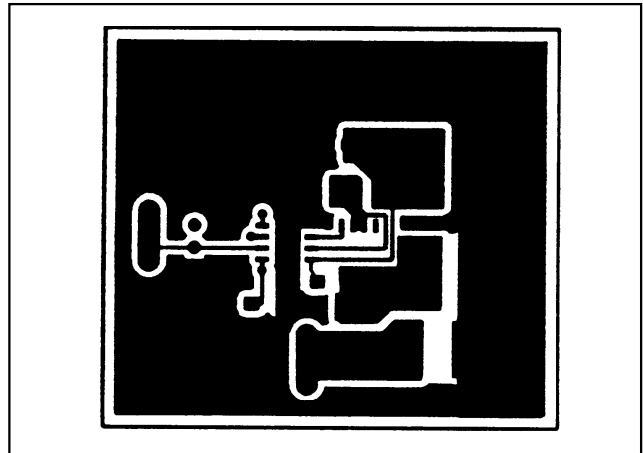

Figure 3. PC Layout (Component Side)

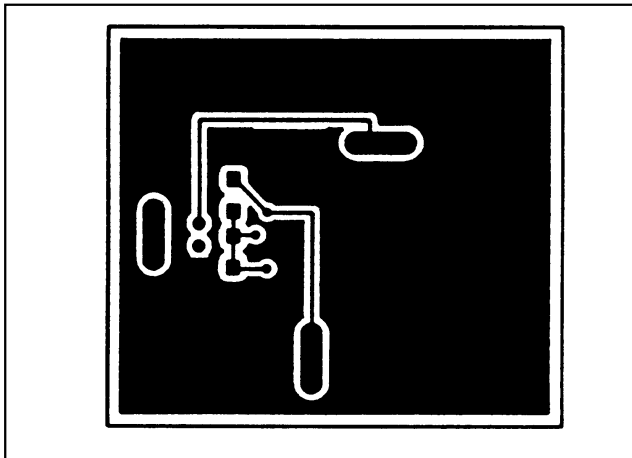

Figure 4. PC Layout (Solder Side)

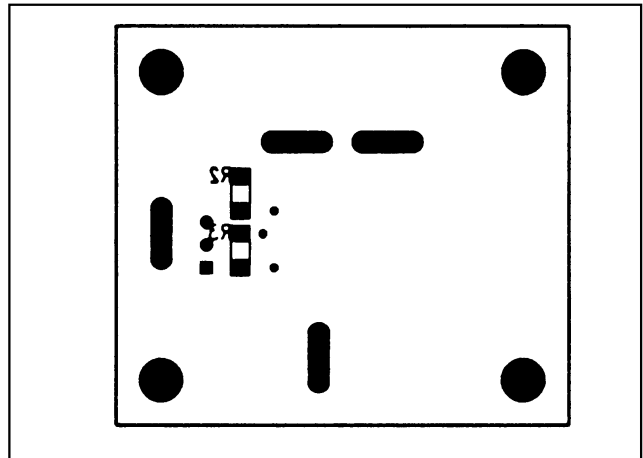

Figure 5. Component Placement Guide (Solder Side)

## Evaluating the MAX775 and MAX776

The MAX775 can replace the MAX774 to generate a -12.0V output voltage with output currents up to 0.5A. The only other modification required is to use a low-ESR output capacitor with a voltage rating of 20V or higher.

The MAX776 can also replace the MAX774 to generate a -15.0V output voltage with output currents up to 0.4A. The only other modification required is to use a low-ESR output capacitor with a voltage rating of 25V or greater. Refer to the *Capacitors* section of the MAX774/MAX775/MAX776 data sheet for more capacitor selection information.

## Other Output Voltages

The MAX774/MAX775/MAX776 are preset for -5V, -12V, and -15V output voltages, respectively. However, they may be adjusted to other values through an external voltage divider formed by R2 and R3 (located on the board's solder side). For input or output voltages greater than 10V, capacitors C1 and C3 must be replaced by capacitors with a higher working voltage. The only other modification required is to cut the trace across R3. The *Output Voltage Selection* section of the MAX774/MAX775/MAX776 data sheet gives instructions for calculating R2 and R3 values.

